

Cosmeceuticals and Active Cosmetics

Third Edition

Cosmeceuticals and Active Cosmetics

Third Edition

Edited by

Raja K. Sivamani, MD, MS, CAT

Department of Dermatology

School of Medicine

University of California, Davis

Sacramento, California, USA

Jared R. Jagdeo, MD, MS

Department of Dermatology

School of Medicine

University of California, Davis

Sacramento, California, USA

Department of Dermatology

State University of New York Downstate Medical Center

Brooklyn, New York, USA

Peter Elsner, MD

Department of Dermatology

Friedrich-Schiller-Universität Jena

and

University Hospital Jena

Jena, Germany

Howard I. Maibach, MD

Department of Dermatology

School of Medicine

University of California, San Francisco

San Francisco, California, USA



CRC Press

Taylor & Francis Group

Boca Raton London New York

CRC Press is an imprint of the
Taylor & Francis Group, an **informa** business

CRC Press
Taylor & Francis Group
6000 Broken Sound Parkway NW, Suite 300
Boca Raton, FL 33487-2742

© 2016 by Taylor & Francis Group, LLC
CRC Press is an imprint of Taylor & Francis Group, an Informa business

No claim to original U.S. Government works
Version Date: 20150731

International Standard Book Number-13: 978-1-4822-1417-8 (eBook - PDF)

This book contains information obtained from authentic and highly regarded sources. While all reasonable efforts have been made to publish reliable data and information, neither the author[s] nor the publisher can accept any legal responsibility or liability for any errors or omissions that may be made. The publishers wish to make clear that any views or opinions expressed in this book by individual editors, authors or contributors are personal to them and do not necessarily reflect the views/opinions of the publishers. The information or guidance contained in this book is intended for use by medical, scientific or health-care professionals and is provided strictly as a supplement to the medical or other professional's own judgement, their knowledge of the patient's medical history, relevant manufacturer's instructions and the appropriate best practice guidelines. Because of the rapid advances in medical science, any information or advice on dosages, procedures or diagnoses should be independently verified. The reader is strongly urged to consult the relevant national drug formulary and the drug companies' and device or material manufacturers' printed instructions, and their websites, before administering or utilizing any of the drugs, devices or materials mentioned in this book. This book does not indicate whether a particular treatment is appropriate or suitable for a particular individual. Ultimately it is the sole responsibility of the medical professional to make his or her own professional judgements, so as to advise and treat patients appropriately. The authors and publishers have also attempted to trace the copyright holders of all material reproduced in this publication and apologize to copyright holders if permission to publish in this form has not been obtained. If any copyright material has not been acknowledged please write and let us know so we may rectify in any future reprint.

Except as permitted under U.S. Copyright Law, no part of this book may be reprinted, reproduced, transmitted, or utilized in any form by any electronic, mechanical, or other means, now known or hereafter invented, including photocopying, microfilming, and recording, or in any information storage or retrieval system, without written permission from the publishers.

For permission to photocopy or use material electronically from this work, please access www.copyright.com (<http://www.copyright.com/>) or contact the Copyright Clearance Center, Inc. (CCC), 222 Rosewood Drive, Danvers, MA 01923, 978-750-8400. CCC is a not-for-profit organization that provides licenses and registration for a variety of users. For organizations that have been granted a photocopy license by the CCC, a separate system of payment has been arranged.

Trademark Notice: Product or corporate names may be trademarks or registered trademarks, and are used only for identification and explanation without intent to infringe.

Visit the Taylor & Francis Web site at
<http://www.taylorandfrancis.com>

and the CRC Press Web site at
<http://www.crcpress.com>

Contents

Preface	ix
Contributors	xi
1. Bakuchiol: A Retinol-Like Functional Compound, Modulating Multiple Retinol and Non-Retinol Targets	1
<i>Ratan K. Chaudhuri</i>	
2. Cutaneous Applications of Caffeine	19
<i>Andrea M. Hui, Jared R. Jagdeo, Neil Brody, and Reena Rupani</i>	
3. Curcumin in Cosmetics: Biochemical Basis for Skin Repair with Use of Topical Curcumin.....	31
<i>Madalene C.Y. Heng</i>	
4. The Cosmetic and Therapeutic Uses for Epicatechin-3-Gallate (EGCG).....	47
<i>Michael S. Leo, Howard I. Maibach, and Raja K. Sivamani</i>	
5. Ellagic Acid	55
<i>William Tuong and Raja K. Sivamani</i>	
6. Gamma-Linolenic Acid–Containing Vegetable Oils	61
<i>Reto Muggli</i>	
7. Hexylresorcinol: Providing Skin Benefits by Modulating Multiple Molecular Targets	71
<i>Ratan K. Chaudhuri</i>	
8. Hydroxyacids	83
<i>Claudine Piérard-Franchimont, Didier Saint-Léger, Sarah Peters, and Gerald E. Piérard</i>	
9. Kinetin.....	91
<i>Stanley B. Levy</i>	
10. Topical Resveratrol	97
<i>Andrea M. Hui, Jared R. Jagdeo, and Neil Brody</i>	
11. Impact of <i>Rhodiola rosea</i> on Skin.....	107
<i>Mahtab Jafari</i>	
12. Silymarin.....	113
<i>Andrew Mamalis and Jared R. Jagdeo</i>	
13. Topical Niacinamide	117
<i>Andrea M. Hui and Bishr Al Dabagh</i>	
14. Anti-Aging Topical Peptides and Proteins	127
<i>Fakhra Khalid, Farzam Gorouhi, and Howard I. Maibach</i>	

15. Amino Acids and Derivatives	163
<i>Kazutami Sakamoto</i>	
16. Antioxidants	177
<i>Frank Dreher, Jens Thiele, and Jacquelyn Levin</i>	
17. Decorative Cosmetics	191
<i>Giorgiana Giancola and Mitchell L. Schlossman</i>	
18. Hair Cosmetics and Cosmeceuticals	221
<i>Robin Alexander</i>	
19. Moisturizers: Treatment of Dry Skin Syndrome and Barrier Defects	235
<i>Marie Lodén</i>	
20. Cosmeceutical Treatments of the Nail	261
<i>Alexandra R. Vaughn and Raja K. Sivamani</i>	
21. Botanicals and Cosmeceuticals for Sun Protection	269
<i>William Tuong, Sandy Kuo, and Raja K. Sivamani</i>	
22. UV Care	281
<i>Kumi Arakane and Eiji Naru</i>	
23. Topical Vitamins E, C, and Ferulic Acid and Topical L-Selenomethionine	297
<i>Karen E. Burke and Doren Madey Pinnell</i>	
24. The Use of Cosmeceuticals in Rosacea	315
<i>Ashley Clark, Whitney A. Fisk, Hadar A. Lev-Tov, and Raja K. Sivamani</i>	
25. Cosmeceutical Treatments for Androgenetic Alopecia	327
<i>Michael S. Leo, Howard I. Maibach, and Raja K. Sivamani</i>	
26. Eczema, Xerosis, and Cutaneous Barrier Repair	331
<i>M. Catherine Mack Correa, Diana R. Johnson, Julie B. Hirsch, and Katharine M. Martin</i>	
27. Melasma and Depigmentation Agents	343
<i>Oma N. Agbai and Susan C. Taylor</i>	
28. The Use of Cosmeceuticals for Oily Skin, Seborrhea, and Seborrheic Dermatitis	357
<i>Negar Foolad, Chelsea Ma, and Raja K. Sivamani</i>	
29. Cosmeceutical Treatments for Purpura	365
<i>Michael S. Leo and Raja K. Sivamani</i>	
30. Vitiligo (Repigmentation Agents)	369
<i>Amir Al-Dabagh, Andrea M. Hui, and Bishr Al Dabagh</i>	
31. Botanical Extracts	385
<i>Alain Khaiat and Claude Saliou</i>	
32. Biomarine Actives	403
<i>Gina Athwal</i>	

33. Analytical Chemistry of Botanical Extracts	411
<i>Susan E. Ebeler and Alyson E. Mitchell</i>	
34. Legal Distinction in the United States between a Cosmetic and a Drug	429
<i>Peter Barton Hutt</i>	
Index	443

Preface

Since the late Professor Albert Kligman popularized the term “cosmeceutical,” the concept of drug-like non-prescription cosmetics has flourished. Why? Presumably the public wishes access, and many governmental regulatory teams concur that the toxicologic risk to the public justifies such marketing.

What has subsequently changed? Chapters in this edition generally provide more quantitative placebo (vehicle) controlled data than was previously available.

We suspect that societal and legal forces will continue to push dermatologic science in this direction—much to the benefit of the consumer.

We thank our authors for their support and patience, and are most appreciative of the careful guidance/assistance of Robert Peden of CRC Press.

Your editors welcome corrections and suggestions for the next edition.

Raja K. Sivamani, MD, MS, CAT

rksivamani@ucdavis.edu

Jared R. Jagdeo, MD, MS

jrjagdeo@gmail.com

Peter Elsner, MD

elsner@derma-jena.de

Howard I. Maibach, MD

Howard.Maibach@ucsf.edu

Contributors

Oma N. Agbai

Department of Dermatology
University of California-Davis
Sacramento, California

Amir Al-Dabagh

Cleveland, Ohio

Bishr Al Dabagh

Department of Dermatology
University of California-San Francisco
San Francisco, California

Robin Alexander

Department of Dermatology
University of California-Davis
Sonoma, California

Kumi Arakane

Research Laboratories
KOSÉ Corporation
Tokyo, Japan

Gina Athwal

Skinergistics Clinical Skin Solutions
Vancouver, British Columbia, Canada

Neil Brody

Department of Dermatology
SUNY Downstate Medical Center
Brooklyn, New York

Karen E. Burke

Department of Dermatology
Mt. Sinai Medical Center
New York, New York

Ratan K. Chaudhuri

Sytheon Ltd.
Boonton, New Jersey

Ashley Clark

School of Medicine
University of California-Davis
Sacramento, California

M. Catherine Mack Correa

Johnson & Johnson Consumer
Companies, Inc.
Skillman, New Jersey

Frank Dreher

NEOCUTIS, Inc.
San Francisco, California

Susan E. Ebeler

Departments of Viticulture and Enology
University of California-Davis
Davis, California

Peter Elsner

Department of Dermatology
Friedrich-Schiller-Universität Jena
and
University Hospital Jena
Jena, Germany

Whitney A. Fisk

Department of Dermatology
University of California-Davis
Sacramento, California

Negar Foolad

Department of Dermatology
University of California-Davis
Sacramento, California

Giorgiana Giancola

Kobo Products, Inc.
South Plainfield, New Jersey

Farzam Gorouhi

Department of Dermatology
University of California-Davis
Sacramento, California

Madalene C.Y. Heng

Department of Dermatology
UCLA School of Medicine
Oxnard, California

Julie B. Hirsch

Johnson & Johnson Consumer
Companies, Inc.
Skillman, New Jersey

Andrea M. Hui

Department of Dermatology
SUNY Downstate Medical Center
Brooklyn, New York

Peter Barton Hutt

Covington & Burling
Washington, District of Columbia

Mahtab Jafari

Department of Pharmaceutical Sciences
University of California-Irvine
Irvine, California

Jared R. Jagdeo

Department of Dermatology
School of Medicine
University of California-Davis
Sacramento, California

and

Department of Dermatology
State University of New York Downstate
Medical Center
Brooklyn, New York

Diana R. Johnson

Johnson & Johnson Consumer
Companies, Inc.
Skillman, New Jersey

Alain Khaiat

Seers Consulting
Fairfax, Virginia

Fakhra Khalid

School of Medicine
University of California-Davis
Sacramento, California

Sandy Kuo

Department of Dermatology
University of California-Davis
Sacramento, California

Michael S. Leo

Department of Dermatology
University of California-San Francisco
San Francisco, California

and

School of Medicine and Public Health
University of Wisconsin-Madison
Madison, Wisconsin

Jacquelyn Levin

Tayani Institute
Mission Viejo, California

Hadar A. Lev-Tov

Department of Dermatology
Albert Einstein College of Medicine
Bronx, New York

Stanley B. Levy

Department of Dermatology
UNC Chapel Hill School of Medicine
Chapel Hill, North Carolina

Marie Lodén

Eviderm Institute AB
Solna, Sweden

Chelsea Ma

School of Medicine
University of California-Davis
Sacramento, California

Howard I. Maibach

Department of Dermatology
School of Medicine
University of California, San Francisco
San Francisco, California

Andrew Mamalis

School of Medicine
University of California-Davis
Sacramento, California

Katharine M. Martin

Johnson & Johnson Consumer
Companies, Inc.
Skillman, New Jersey

Alyson E. Mitchell

Departments of Food Science and
Technology
University of California-Davis
Davis, California

Reto Muggli

Adviserv Consulting
Hofstetten, Switzerland

Eiji Naru

Research Laboratories
KOSÉ Corporation
Tokyo, Japan

Sarah Peters

Department of Clinical Sciences
Liège University
Liège, Belgium

Gerald E. Piérard

Department of Clinical Sciences
Liège University
Liège, Belgium

Claudine Piérard-Franchimont

Department of Dermatopathology
Liège University Hospital
and
Department of Clinical Sciences
Liège University
Liège, Belgium

Doren Madey Pinnell

Department of Dermatology
Duke University Medical Center
Durham, North Carolina

Reena Rupani

Department of Dermatology
SUNY Downstate Medical Center
Brooklyn, New York

Didier Saint-Léger

DSL Consult
Paris, France

Kazutami Sakamoto

Chiba Institute of Science
Chiba, Japan

Claude Saliou

Claude Saliou Consulting LLC
Basking Ridge, New Jersey

Mitchell L. Schlossman

Kobo Products, Inc.
South Plainfield, New Jersey

Raja K. Sivamani

Department of Dermatology
School of Medicine
University of California-Davis
Sacramento, California

Susan C. Taylor

Society Hill Dermatology and Cosmetic Center
Philadelphia, Pennsylvania

Jens Thiele

Dermatology Specialists, Inc.
Oceanside, California

William Tuong

School of Medicine
University of California-Davis
Sacramento, California

Alexandra R. Vaughn

Drexel University College of Medicine
Philadelphia, Pennsylvania

1

Bakuchiol: A Retinol-Like Functional Compound, Modulating Multiple Retinol and Non-Retinol Targets

Ratan K. Chaudhuri

Background

Bakuchiol (Figure 1.1; Phenol, 4-[1E, 3S]-3-ethenyl-3, 7-dimethyl-1, 6-octadienyl) was first isolated by Mehta et al. from the *Psoralea corylifolia* seed in 1973.¹ Absolute configuration of bakuchiol was established in the same year by Parakasarao et al.² Bakuchiol has one asymmetric center and is shown to possess (S)-chirality.³ Mechanistically, both the 4-hydroxystyryl and terpenic moieties of the compound seem to be important for its bioactivity. Total synthesis was also accomplished in 1973.⁴ Banerji and Chintalwar reported the biosynthesis of bakuchiol and established the pathway by using phenylalanine and mevalonic acid as substrates.^{5,6}

Bakuchiol is mainly obtained from the seeds of the plant *Psoralea corylifolia*, which is widely used in Indian as well as in Chinese medicine to treat a variety of diseases.⁷ Traditional medicine practitioners in India and China have utilized the plant for centuries. *Psoralea corylifolia* is known by a wide variety of names, suggesting its widespread use. For example, babchi, baguchi, babachi, Bakchi in Hindi and by many other names depending on the Indian languages; Ravoli in Sri Lanka; Boh-gol zhee in Korea; Buguzhi in Chinese.⁷ A recent chapter on *P. corylifolia* describes its botany, phytochemistry, and ethnopharmacology, along with the various pharmacological activities of the plant.⁸ Bakuchiol has also been isolated from other plants, such as *P. grandulosa*,^{9,10} *P. drupaceae*,¹¹ *Ulmus davidiana*,¹² *Otholobium pubescens*,¹³ *Piper longum*,¹⁴ and *Aerva sanguinolenta* Blum.¹⁵

Structurally, bakuchiol (Figure 1.1) belongs to the family of meroterpenes. Meroterpenes are terpenes having an aromatic ring in the chemical structure. The term meroterpenoid was first applied by Cornforth, in 1968, to describe natural products of mixed biosynthetic origin which are partially derived from terpenoids.¹⁶ They are typically derived from higher plants though they have also been obtained from fungi¹⁷ as well as having been produced synthetically. Meroterpenes are also widely distributed in marine organisms. They are particularly abundant within brown algae, but other important sources include microorganisms and invertebrates.¹⁸ Interestingly, the 4-hydroxystyryl functionality present in bakuchiol is also present in resveratrol (Figure 1.2).¹⁹

Bakuchiol possesses antioxidant,^{20–23} anti-inflammatory^{24,10,25,26}, anti-bacterial,²⁷ anti-tumor,^{28,29} cytotoxic,³⁰ heptaprotective,³¹ and caspase-3 dependent apoptosis³² properties. The cytotoxicity of bakuchiol is mainly due to its DNA polymerase 1 inhibiting activity.³³ Although bakuchiol has shown many physiological properties and has been known since 1973, its first commercial use in topical applications did not occur until 2007 when it was introduced to the market under the trade name Sytenol® A by Sytheon Ltd. of Boonton, New Jersey. The focus of this chapter is twofold. The first is to show evidence of bakuchiol's functional resemblance to retinol (Figure 1.3). The second is to provide an overview of the important physiological and biological properties of bakuchiol as they relate to three key skin care applications—(1) preventative & restorative anti-aging; (2) anti-acne; and (3) skin lightening/even toning—and the mechanisms by which it provides these benefits. Additionally, this chapter has been extended to include a few key targets that may have applications beyond skin care, as well as provide an overview of bakuchiol's antibacterial properties.

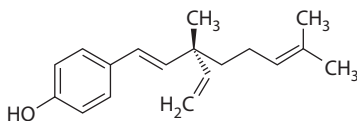

FIGURE 1.1 Structure of bakuchiol.

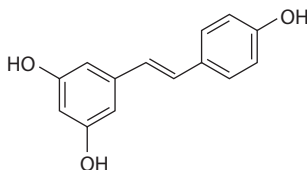

FIGURE 1.2 Structure of resveratrol.

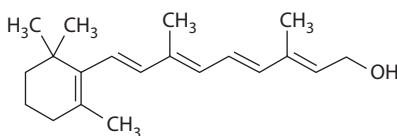

FIGURE 1.3 Structure of retinol.

Bakuchiol, a Functional Analog of Retinol

From the perspective of topically applied compositions, a small molecule that safely mimics the properties of retinol³⁴ (Figure 1.3) in reversing signs of aging, providing skin protection from sun-induced damage, providing solutions to problem skin, like acne and rosacea, and modulating pigmentation control, is a greatly sought after ingredient. Recently, Chaudhuri, using a simple comparative gene expression profiling of retinol and bakuchiol in a reconstituted full thickness skin substitute model, established a basis for making a claim that bakuchiol is a functional analog of retinol.³⁵ The journey from gene to protein is complex and tightly controlled within each cell. It consists of two major steps: transcription and translation. Together, transcription and translation are known as gene expression. Figure 1.4 illustrates the molecular signatures of retinol and bakuchiol through the volcano plot presentation of a DNA microarray experiment. The comparison of the volcano plots for bakuchiol (Figure 1.4a) and retinol (Figure 1.4b) shows similar overall shape, indicating similar overall modulation of gene expression in the skin substitute model. The effects of both compounds on specific pathways relevant to retinol functionality were then compared. First, a similar modulation of many (however, not all) genes coding for retinoid binding and metabolizing proteins was observed. A brief description of these genes as well as the impact of retinol and bakuchiol on each is presented in Table 1.1. Similarly, many genes involved in the generation and maintenance of the extracellular matrix (ECM) and the dermal-epidermal junction (DEJ) were similarly modulated by both retinol and bakuchiol.³⁶ Based on this and other data, Chaudhuri concluded that bakuchiol can function as a retinol-like compound through retinol-like regulation of gene expression.

Preventative and Restorative Anti-Aging

Targeting skin concerns early on can effectively prevent damage to the skin's surface and improve skin quality. Slowing down the aging process can be achieved by (i) antioxidant protection to limit direct oxidative damage to the cells, proteins, and DNA, (ii) controlling inflammation to minimize inflammation-induced skin damage, and (iii) use of sunscreen protection to prevent photodamage. The mechanisms and the sequence of events by which free radicals, the main culprit of oxidative damage, interfere with cellular

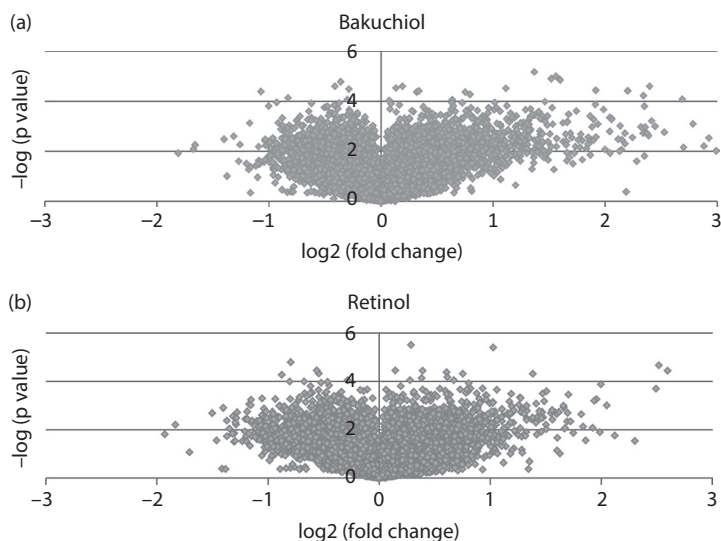

FIGURE 1.4 (a) Volcanic plot of DNA microarray data—Retinol. (b) Volcanic plot of DNA microarray data—Bakuchiol. (From Chaudhuri RK, Bojanowski K. *Int J Cosmet Sci* 2014;36(3):221–30. With permission.)

functions are not fully understood; but one of the most important events seems to be lipid peroxidation, which results in cellular membrane damage. This cellular damage causes a shift in the net charge of the cell, changing the osmotic pressure, leading to swelling and eventually cell death.³⁷

Antioxidant

Multiple lines of compelling evidence substantiate the beneficial effects provided by the use of antioxidants. Direct application of antioxidants to skin has the added advantage of targeting antioxidants to those areas of the skin needing the protection most and, obviously, can easily be achieved. Topical application adds low molecular-weight antioxidants to the skin reservoir where they are available to protect the skin against oxidative stress. *Psoralea corylifolia* has a number of antioxidative components; bakuchiol is one of the most abundant and powerful antioxidants present in this plant.²¹ Bakuchiol not only interferes with different free radical-producing systems, which are described below; but it also increases the function and effectiveness of endogenous antioxidants.

Haraguchi et al. have reported that bakuchiol inhibited NADPH-, ascorbate-, t-BuOOH-, and CCl(4)-induced lipid peroxidation in microsomes.²¹ Indeed, bakuchiol was the most potent antioxidant in microsomes and its inhibition of oxygen consumption induced by lipid peroxidation was time-dependent. Bakuchiol also inhibits microsomal lipid peroxidation in a concentration-dependent manner showing 74.7% protection at a concentration of 10 μM . Bakuchiol also prevented NADH-dependent and ascorbate-induced mitochondrial lipid peroxidation. In view of its solubility in lipid and water (at higher pH), bakuchiol is expected to be distributed in both of these phases. This may account for its low $\text{IC}_{50} = 6.1 \pm 0.2 \mu\text{M}$ value against lipid peroxidation.^{20,38}

Bakuchiol has also been found to protect human red blood cells against oxidative hemolysis and to protect against oxidative stress-induced retinal damage. With respect to the latter, bakuchiol attenuated optic nerve crush (ONC)-induced up-regulation of apoptotic proteins, including cleaved poly ADP ribose polymerase (PARP), cleaved caspase-3, and cleaved caspase-9.³⁹ Bakuchiol also significantly inhibited translocation of mitochondrial apoptosis induced factor (AIF) into the nuclear fraction and release of mitochondrial cytochrome c into the cytosol.

In validation of the foregoing effect, Chaudhuri and Marchio have recently shown that bakuchiol has broad-spectrum antioxidant activity (*in vitro*) and effectively quenches superoxide-, hydroxy-, peroxy-, peroxy-nitrile radicals, and singlet oxygen non-radical in addition to inhibiting lipid peroxidation.²³ As

TABLE 1.1

Fold Change in the DNA Microarray Experiment, and Role of Modulated Retinoid Binding and Metabolizing Genes (R: retinol; B: bakuchiol)

Gene	Full Name	Function and Comments
CRBP I; CRBP II; CRBP IV	Cellular retinol binding protein I, II and IV	CRBP I:R = 2.6; B = 4.2 CRBP II: R = NS; B = 4.1 CRBP IV: R = NS; B = 3.1 CRBP I mediates the cellular uptake of retinol, solubilizes and detoxifies it for further transport within the cytoplasm, and presents it to the appropriate enzymes to biosynthesize retinoic acid.
N6AMT2	N-6 adenine-specific DNA methyltransferase 2	R = NS; B = -2.1 Retinoic acid resistance might be overcome by the use of epigenetic modifying agents such as DNA methyl transferase inhibitors. Down-regulation provided by bakuchiol may reduce retinoic acid-induced toxicity.
TIG1	Tazarotene-inducible gene 1	R = 13.2; B = 12.9 Retinoid acid (RA) receptor-responsive gene. The expression of this gene is found to be down-regulated in a variety of human cancers as well as in acne, rosacea, and psoriasis. Up-regulation by bakuchiol may provide a solution to problem skin. Anti-acne clinical study results of bakuchiol has recently been reported (40).
DHRS9	Dehydrogenase/reductase SDR family member 9 precursor	R = 5.5; B = 11.6 DHRS9 is involved in converting retinol to retinal and then to retinoic acid, the rate-limiting step for the biosynthesis of retinoic acid.
RETSAT	All-trans-13,14-dihydroretinol saturase	R = -2.9; B = -2.8 RETSAT expression is involved in adipocyte differentiation.
LRAT	Lecithin-retinol acyltransferase	R = 12.3; B = 82.2 Retinol esterification with long-chain fatty acid by LRAT is the key step in both absorption and storage of retinol.
CYP1A1; CYP1A2	Cytochrome P450	CYP1A1: R = 4.0; B = 4.9 CYP1A2: R = 3.6; B = 6.7 In addition to retinol dehydrogenase, P450s 1A1 and 1A2 genes are the major human P450s that catalyze the reaction of retinol to retinal.
RARB; RARG	Retinoic acid receptor beta -1; Retinoic acid receptor gamma -1	RARB: R = 5.6; B = NS RARG: R = 1.8; B = NS The actions of retinoids are generally mediated by the retinoic acid receptors (RARs alpha, beta, and gamma) and the retinoid X receptors (RXRs alpha, beta, and gamma). Both RARB and RARG are up-regulated, as expected, by retinol but not with bakuchiol.

presented in [Table 1.2](#), its antioxidant profile, especially with respect to lipid peroxidation inhibitory activity, is far superior to natural tocopherol, a common topical antioxidant. Bakuchiol was found to be 60-fold more effective in inhibiting squalene than natural tocopherol (IC_{50} for bakuchiol 0.5 $\mu\text{g/mL}$ vs. natural tocopherol 30 $\mu\text{g/mL}$). Squalene is particularly prone to photooxidation during sun exposure.⁴⁰ Hence, bakuchiol is expected to protect squalene and other skin lipids from oxidation due to its excellent lipid peroxidation inhibitory activity.

The protective activity of bakuchiol against oxidative damage to lipids and proteins has been investigated and rationalized based on the scavenging activity of bakuchiol against various oxidizing radicals including $\text{Cl}(3)\text{CO}(2)^*$, linoleic acid peroxy radicals, LOO^* , DPPH radicals, $(^*)\text{OH}$, and glutathionyl radicals by Adhikari et al.²⁰ The rate constants of the scavenging reactions, the transients formed in these reactions, and their mechanistic pathways have been probed using an optical pulse radiolysis technique. The methyl ether derivative of bakuchiol was also shown to prevent lipid peroxidation in rat brain homogenate, indicating participation of the terpenoid chain in scavenging LOO^* . In their study,

TABLE 1.2

Antioxidant Profile of Bakuchiol and Natural Tocopherol

Unit ^a	Peroxy	Hydroxy	Superoxide	Peroxynitrite	Singlet Oxygen	Lipid Peroxidation ^b
Bakuchiol	15,165	569	204	130	1,325	0.5
Tocopherol natural	813	Not detected	Not detected	1	1,110	30

^a μ mole Trolox equivalent/g.^b Squalene was used as a substrate for lipid peroxidation inhibitory activity; data is expressed in IC₅₀ in μ g/mL.

Adhikari et al. were able to demonstrate that the allylic radical formed initially was transformed into the phenoxy radical at a later stage. These findings revealed the importance of the terpenoid moiety of bakuchiol in controlling its antioxidant action via radical scavenging.

Many studies have established that oxidative stress and mitochondrial dysfunction are two central factors contributing to the aging process. Bakuchiol was shown by Haraguchi et al. to be very effective in protecting mitochondrial functions against oxidative stress.²² As noted earlier, bakuchiol prevented mitochondrial lipid peroxidation, inhibiting oxygen consumption originating in lipid peroxidation, in a time-dependent manner. Bakuchiol was also found to protect mitochondrial respiratory enzyme activities against both NADPH-dependent and dihydroxyfumarate-induced peroxidation injury.

ATP generation is an essential function in mitochondria. Recently, Seo et al. examined the effect of *Psoralea corylifolia* seed (PCS) extract on ATP synthesis. They found that both PCS extract and bakuchiol increased ATP synthesis in the hepatocytes of old mice whose ATP synthesis had been reduced by H₂O₂ treatment. Seo et al. further examined the impact of PCS extract on the integrity of the mitochondrial membrane structure which, according to Tsujimoto and Shimizu,⁴¹ is involved in ATP energy production and mitochondrial function. According to their findings, PCS extract treatment led to a recovery in the mitochondrial membrane potential whose reduction had been induced by oxidative stress, evidencing a stimulation of mitochondrial respiration and restoration of mitochondrial energy metabolism.⁴² These authors were also able to demonstrate that PCS extract and bakuchiol guarded against mitochondrial genome damage.

Another possible mechanism by which bakuchiol acts in addressing oxidative damage and stress is through interaction with various enzyme systems, especially those associated with the endogenous antioxidant defense system. Efficacy may, at least in part, manifest from a two pronged effort involving both radical scavenging and an interaction with enzyme functions. As presented in Table 1.3, in a side-by-side comparison with retinol, bakuchiol has been shown to stimulate the endogenous antioxidant defense system using a reconstituted full thickness skin substitute model. As indicated, with one exception,

TABLE 1.3

Gene Expression Profile of Bakuchiol and Retinol Related to Endogenous Antioxidant System

Gene	Gene Description	Function	Fold Change vs. Control	
			Retinol	Bakuchiol
GPX3	Glutathione peroxidase 3 precursor/extracellular glutathione peroxidase	Protect organism from oxidative damage. Reduce lipid hydroperoxides \rightarrow alcohols and hydrogen peroxide \rightarrow water	+2.5	+3.2
GSTT1	Glutathione S-transferase theta -1	Involved in the detoxification of endogenous compounds, such as peroxidized lipids, as well as the metabolism of xenobiotics.	+2.9	+3.0
GSTP1	Glutathione S-transferase P 1	Same as above	+2.8	+3.0
NQO1	NAD(P)H dehydrogenase [quinone]	This protein's enzymatic activity prevents the one electron reduction of quinones that results in the production of radical species	No effect	+5.0

bakuchiol and retinol showed a remarkably similar gene expression pattern with a very high statistical significance ($p \leq 0.05$). The only exception was that retinol had no effect on the NQO1 gene whereas bakuchiol had a fivefold stimulatory effect. NAD(P)H:quinone oxidoreductase 1 (NQO1) is a cytosolic protein that catalyzes metabolic detoxification of quinones, thereby protecting cells against quinone-induced oxidative stress, cytotoxicity, and mutagenicity.⁴³

Inflammation

Skin aging and inflammation are critically linked. Enzymes associated with inflammation and the inflammatory responses, particularly chronic inflammation, are known to accelerate skin aging and degradation. Among the enzymes that synthesize pro-inflammatory mediators from the arachidonic acid pathway are the cyclo- and lipo-oxygenases.⁴⁴ Bakuchiol has moderate inhibitory activities against both 5-lipoxygenase (IC_{50} 23.5 μ M)²⁴ and cyclooxygenase-1 and -2 (IC_{50} 14.7 and 514 μ g/mL).²³ Studies have revealed that bakuchiol is a weak inhibitor of secretory and intracellular phospholipase A2 (PLA2) but dose-dependently reduced the formation of leukotriene B4 (LTB4) and thromboxane B2 (TXB2) by human neutrophils and platelet microsomes, respectively.²⁴ Additionally, bakuchiol inhibited degranulation in human neutrophils, whereas superoxide generation was not affected. In mice, bakuchiol decreased cell migration, myeloperoxidase activity, and eicosanoid levels in the air pouch inflammation induced by zymosan. Applied topically, bakuchiol was also found to be effective as an inhibitor of edema and myeloperoxidase activity in the 12-O-tetradecanoylphorbol 13-acetate (TPA)-induced ear edema and significantly reduced the PGE2 content and ear edema in the arachidonic acid-induced response. Bakuchiol is a natural anti-inflammatory agent that, among others, is able to control leukocytic functions such as eicosanoid production, migration, and degranulation in the inflammatory site. Inhibitory effects of bakuchiol in pro-inflammatory arachidonic acid pathway are summarized in Figure 1.5.

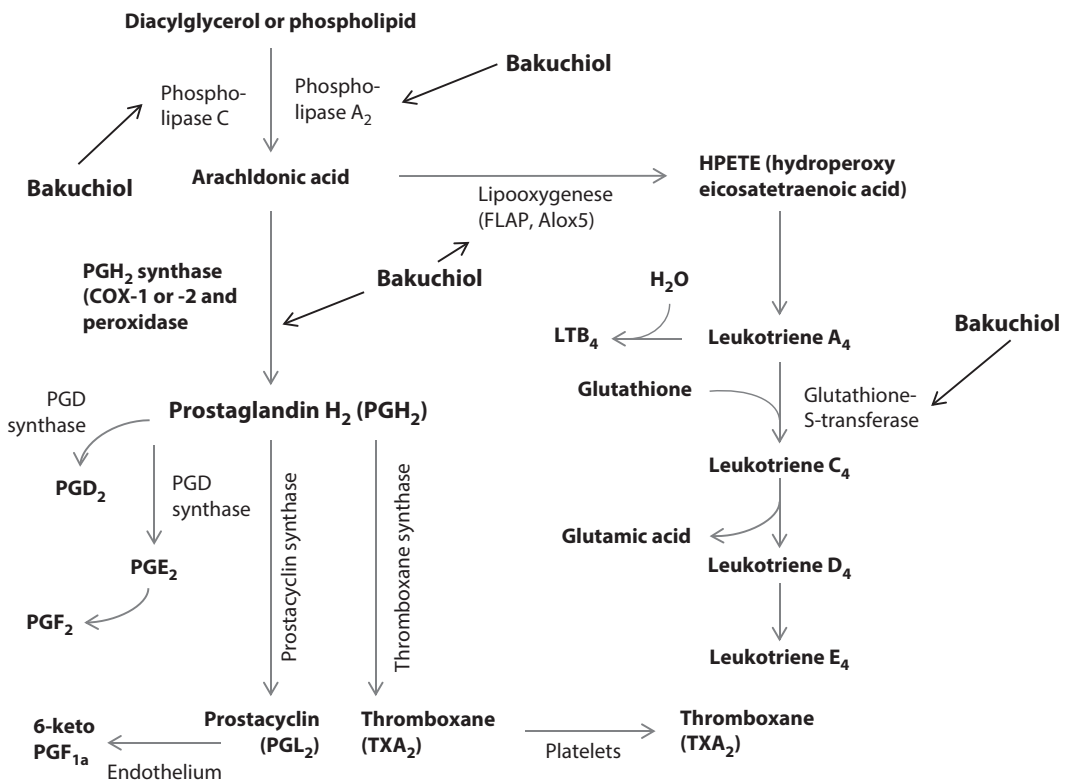

FIGURE 1.5 Bakuchiol inhibits multiple sites in pro-inflammatory arachidonic acid pathway.

TABLE 1.4

Pro-Inflammatory Gene Modulation by Bakuchiol and Retinol

Gene	Gene Description	Function	Fold Change vs. Control	
			Bakuchiol	Retinol
COX-1/PTGS1	Cyclooxygenase-1 (prostaglandin G/H synthase precursor)	Prostaglandin biosynthesis; acts as both a dioxygenase and a peroxidase	-3.6	-3.4
PLAA	Phospholipase A-2-activating protein	PLAA releases fatty acids from the second carbon group of glycerol. Upon downstream modification by cyclooxygenases, arachidonic acid is modified into eicosanoids. Eicosanoids include prostaglandins and leukotrienes, which are categorized as inflammatory mediators.	-7.7	No effect
PLA2G4A	Cytosolic phospholipase A2	Catalyzes hydrolysis of membrane phospholipids to release arachidonic acid, which is subsequently metabolized into eicosanoids	-2.6	-3.1
PTGER2	Prostaglandin E2 receptor EP2 subtype	Inflammatory reaction via the EP2 receptor through its regulation of TNF-alpha and IL-6	-2.4	-2.2
PTGER4	Prostaglandin E2 receptor EP4 subtype	Inflammatory reaction via the EP4 receptor through its regulation of TNF-alpha and IL-6	-6.1	-3.0
HPGD/15PGDH	15-Hydroxy prostaglandin dehydrogenase	HPGD is a catabolic enzyme controlling the biological activities of prostaglandins by converting them into inactive keto-metabolites	+21.8	+4.1

Validating the anti-inflammatory effect of bakuchiol, Chaudhuri conducted comparative gene expression profiles of bakuchiol and retinol on several pro-inflammatory genes using a reconstituted full thickness skin substitute model. As presented in Table 1.4, with the exception of two genes, phospholipase A-2-activating protein (PLAA) and 15-hydroxy prostaglandin dehydrogenase (HPGD) (15-PGDH), bakuchiol and retinol showed remarkable similarity in the down-regulation of the inflammatory genes. In the case of PLAA, bakuchiol produced a sevenfold down-regulation whereas retinol had no effect on PLAA. With HPGD, bakuchiol showed a 22-fold up-regulation in comparison to retinol's fourfold up-regulation. The HPGD gene encodes the enzyme HPGD, a member of the short-chain non-metallo-enzyme alcohol dehydrogenase protein family, which is a catabolic enzyme controlling the biological activities of prostaglandins by converting them into inactive keto-metabolites. Reduced expression of HPGD contributes to the elevated levels of prostaglandins found in the skin following UVR exposure as demonstrated by Judson et al.⁴⁵ Following on their findings, these authors speculated that agents which prevent UVR-mediated down-regulation of HPGD could affect the acute or the long-term consequences of UVR exposure, including nonmelanoma skin cancer.

Erythema, a common form of inflammation, is the most obvious clinical sign of UV radiation exposure and becomes readily apparent within 6 h or less of UV exposure and is maximal at about 24 h.⁴⁶ COX dependent prostaglandin E₂ (PGE₂) is believed to be one of the mediators of UVR-induced erythema. Phospholipase A₂ (PLA₂), whose synthesis occurs only when skin is exposed to UV doses sufficient to cause erythema, is considered a rate limiting step in the generation of leukotrienes and prostaglandins. Hence, the two are intertwined in regards to erythema and their impact thereon.

Building upon the results attained in the above-mentioned investigation of the impact of bakuchiol and retinol on inflammation-related gene expression, Chaudhuri conducted a clinical study (unpublished) to assess the skin protection property of bakuchiol against erythema.⁴⁷ In this study, Chaudhuri determined the average L-, a-, and ITA (Individual Typology Angle) values of treated (with

TABLE 1.5

Reduction in Erythema Using 1% Bakuchiol Lotion

	Pre-Irr	Post-Irr	Δ L or Δ ITA Value or Δ a-Value
L-value (with bakuchiol)	65.69	66.25	-0.56
L-value (without bakuchiol)	66.45	60.71	-5.74 (Statistically significant $p < 0.001$)
ITA (with bakuchiol)	43.97	46.83	+2.86
ITA (without bakuchiol)	46.05	36.76	-9.29 (Statistically significant $p < 0.001$)
a-value (with bakuchiol)	8.53	8.38	-0.15
a-value (without bakuchiol)	8.17	16.32	+8.15 (Statistically significant $p < 0.001$)

a 1% bakuchiol lotion) and untreated skin of 10 human volunteers prior to irradiation/UV exposure (“Pre-Irr”) and following irradiation/UV exposure (“Post-Irr”). As presented in Table 1.5, the results clearly showed a marked reduction in the manifestation of erythema, as evidenced by the significant difference in the delta or change in the L-, a-, and ITA values in those areas that were treated with the bakuchiol containing lotion as compared to the untreated areas.

More recently the role of nitric oxide (NO) as a contributor to the UV erythema response has been established.⁴⁸ NO is produced in the skin by NO synthase that can combine with superoxide to form peroxynitrite, a highly reactive oxidant and mediator of tissue injury. Similarly, large amounts of nitric oxide (NO) production following the induction of an inducible NO synthase (iNOS) gene has also been implicated in the pathogenesis of various inflammatory diseases. Bakuchiol has been shown to inhibit NO production in RAW 264.7 macrophages activated with interferon- γ and lipopolysaccharide. The mechanistic studies showed that bakuchiol inhibited the expression of iNOS mRNA through the inactivation of NF- κ B.²⁵ Thus, bakuchiol is also expected to protect skin from UV induced erythema as well as from damage due to sun-induced iNOS gene over-expression.

Matrix Metalloprotease (MMP)

A major characteristic of aged and prematurely aged skin is a high degree of fragmentation of the dermal collagen matrix.⁴⁹ MMPs play a major role in protein and collagen degradation, which affects the structural integrity of the dermis. In normal skin, its production is in balance with their natural inhibitors tissue inhibitors of metalloproteinases (TIMPs); however, UV light is reported to enhance the synthesis of MMP in human skin *in vivo* leading to MMP-mediated collagen destruction. Sun exposure, especially substantial sun exposure, leads to an imbalance between the active enzymes, the MMPs, and their natural inhibitors (TIMPs) resulting in the accelerated destruction of connective tissues⁵⁰ and photoaging.⁵⁰ Therefore, protection of extracellular matrix proteins, such as collagens, in aged or photoaged human skin by the reduction of MMPs would be expected to retard the clinical manifestations of skin aging.

In this regard, it is well documented that retinol treatment (human clinical) reduces matrix metalloprotease expression and stimulates collagen synthesis in naturally aged, sun-protected skin and, perhaps more importantly, in photodamaged skin.⁵¹ Given the many similar targets of retinol and bakuchiol, Chaudhuri compared the performance of bakuchiol and retinol on two key matrix metalloproteases, MMP-1 and MMP-12. As presented in Table 1.6, bakuchiol has a significant inhibitory effect on MMP-1

TABLE 1.6

Matrix Metalloprotease Inhibitory Activity of Bakuchiol and Retinol

Matrix Metalloprotease	Methods Used	Bakuchiol	Retinol
MMP-1 (collagenase)	Enzcheck collagenase assay kit (molecular probe)	50% inhibition at 1 mg/mL	Not determined
MMP-12 (elastase)	Calbiochem human neutrophilic elastase kit (Cat # 324681)	70% inhibition at 1 μ g/mL	8% inhibition at 1 μ g/mL

and a markedly stronger inhibitory effect on MMP-12, far exceeding the effect of retinol (Table 1.6). Thus, based on retinol's known effectiveness and these results, it is expected that bakuchiol will provide an even stronger protection to the extracellular matrix proteins *in vivo*.

Extracellular Matrix Proteins

Emerging evidence indicates that intrinsic, chronological aging of the skin shares several mechanistic features with photoaging.⁴⁸ For example, collagen fragmentation is responsible for the loss of structural integrity and the impairment of fibroblast function in aged as well as photoaged human skin. In aged skin, collapsed fibroblasts produce low levels of collagen and high levels of collagen-degrading enzymes. This imbalance advances the aging process in a self-perpetuating, never-ending deleterious cycle. Treatments that stimulate production of new, non-fragmented collagen are, therefore, expected to provide substantial improvement in the appearance, health, and integrity of aged skin. Indeed, treatments such as topical retinol or retinoic acid have been clinically proven to stimulate production of new, undamaged collagen.⁴⁹ The attachment of fibroblasts to this new collagen allows stretch, which in turn balances collagen production and degradation, thereby slowing, if not reversing, the aging process.

Numerous studies have shown the restorative effects of topical application of all-*trans* retinoic acid (RA) on aging skin, including the partial restoration of collagens I, III,⁴⁷ and VII⁵² and the restoration of the fibrillin-rich microfibrillar network.⁵³ These extracellular matrix (ECM) changing together with reduced MMP expression may, in part, explain the clinical improvement of photoaged skin produced by topical retinoids. In light of the similarities in targets of retinol and bakuchiol, one may also expect similar performance of bakuchiol in this regard as well.

In an effort to validate their DNA microarray analysis of the comparative effects of bakuchiol and retinol on collagen stimulation, Chaudhuri and Bojanowski measured collagen stimulation by ELISA and histochemistry methods. The ELISA assessment employed cell-culture conditioned media from neonatal (type I and IV collagens) or mature (type III collagen) fibroblasts.³⁶ Their findings, as summarized in Table 1.7, not only confirmed the up-regulation of types I and IV collagen in the DNA microarray study and the stimulation of type III collagen in the mature fibroblast model, but also demonstrated a significant improvement in collagen stimulation as compared to retinol. Hence, even greater restorative properties may be found with bakuchiol.

Skin Hydration and Barrier Homeostasis

Water homeostasis of the epidermis is essential for the normal function of the skin and for normal stratum corneum (SC) hydration. Dehydration of the SC is a typical characteristic of skin aging, especially in photoaged skin, and of many diseases associated with dry skin.⁵⁴ Water homeostasis is a determinant of skin appearance, mechanical properties, barrier function, and metabolism. In addition, it is indispensable in maintaining proper water balance of the body itself. One of the key genes associated with skin hydration and barrier homeostasis is CDH1, epidermal cadherin. Epidermal cadherin (E-cadherin) is essential for water barrier formation and is required for correct tight junction formation. Loss of E-cadherin in the epidermis *in vivo* results in prenatal death of mice due to the inability to retain a functional epidermal water barrier. E-cadherin regulates claudin-1, claudin-4, and ZO-1 localization by activating aPKC, which is implicated in tight junction formation and is considered to be a key protein for maintaining skin homeostasis.⁵⁵ Using EpiDermFT skin substitute, Chaudhuri and Bojanowski³⁶ have shown that both retinol and bakuchiol increased expression of CDH1 as well as AQP3, another

TABLE 1.7

Comparative Collagen Stimulatory Effects of Bakuchiol and Retinol

Test Material (10 µg/mL)	Collagen I	Collagen III	Collagen IV
Bakuchiol	147	150	119
Retinol	119	148	100

TABLE 1.8

Gene Expression Profile of Bakuchiol and Retinol Related to Skin Hydration and Barrier Homeostasis

Gene	Gene Description	Function	Fold Change vs. Control	
			Bakuchiol	Retinol
AQP3	Aquaporin 3	Aquaporin 3 is the water/glycerol transporting channel protein expressed in the epidermis which helps maintain the right level of skin hydration, elasticity, and barrier recovery.	4.3	3.5
CDH1	E-cadherin	Essential for water barrier formation and is required for correct tight junction formation	21.6	9.4

gene associated with water transport and whose expression is decreased during aging.⁵⁶ As indicated in Table 1.8, while the two had similar effects on AQP3, bakuchiol produced a marked increase in the gene expression of E-cadherin.

Following on the gene expression study, Chaudhuri and Bojanowski also conducted a clinical study demonstrating the anti-aging efficacy of a topical composition containing just 0.5% bakuchiol.³⁶ In that study, the composition was applied to the face of 17 healthy female subjects ranging in age from 40 to 65 years and who showed outward evidence of photoaging, including wrinkles, sagging, spots, and a dull complexion on the face, twice a day for 12 weeks. (One subject was removed from the study due to protocol violation.) Each subject's facial skin was evaluated through self-assessment, clinical grading, and instrument measurements, over the course of the treatment to assess any changes in the appearance of fine lines and wrinkles, elasticity, firmness, even toning, and overall signs of photodamage. Although some improvement was noted in most of the parameters after just four weeks, significantly more improvement was noted after the eighth week. These improvements continued to increase, even faster through the twelfth week of product application, indicating, perhaps, a certain degree of cumulative beneficial effect over time. These results were consistent amongst all three evaluation methodologies employed. Additionally, these results provided the ultimate validation of the *in vitro* results noted previously and were in line with the retinoid-type functionality of bakuchiol.

Anti-Acne

Acne is a complex, chronic, and common skin disorder of pilosebaceous units. There are four major targets presently governing acne therapy as follows: correcting the altered pattern of follicular keratinization; decreasing sebaceous gland activity; decreasing the follicular bacterial population, especially *P. acnes*; and producing an anti-inflammatory effect by inhibiting the production of extracellular inflammatory products through the inhibition of these microorganisms.⁵⁷ Dihydrotestosterone (DHT) is not only involved in sebum production but also involved in the production of pro-inflammatory cytokines in acne.⁵⁸ In recent years there has been an increasing focus on the extent to which oxidative stress is involved in the pathophysiology of acne. Emerging studies have shown that patients with acne are under increased cutaneous and systemic oxidative stress. Indeed, there are indications that lipid peroxidation itself triggers the inflammatory cascade in acne.⁵⁹

Chaudhuri and Marchio have demonstrated that bakuchiol effectively reduces acne and is more effective when combined with salicylic acid.²³ Table 1.9 sets forth their findings presented as percent reduction in acne using the Global Acne Grading System.⁶⁰ Based on the results, formulations containing the combination of 1% bakuchiol and 2% salicylic acid showed a nearly 70% reduction in acne lesions and inflammation, as judged by the acne grading system. The next best results was attained with the 1% bakuchiol by itself, which reduced acne by a score of about 57%; whereas 2% salicylic acid only reduced acne by about 48%. As expected, practically no improvement in the reduction of acne was evident in the control group. None of the subjects observed or reported any adverse reaction using these formulated products. These results clearly show that bakuchiol is an effective ingredient, especially when combined with an exfoliating agent like salicylic acid, for the treatment of acne.

TABLE 1.9

Percent Reduction in Acne after Bakuchiol Treatment

Group #	Type of Lotions	Number of Volunteers	% Reduction in Acne after Treatment		
			2 weeks	4 weeks	6 weeks
1	1% bakuchiol	13 ^a	30	42	57
2	2% salicylic acid	14 ^b	21	34	48
3	1% bakuchiol +2% salicylic acid	14 ^a	26	48	67
4	control	15	5	5	11

^a Two dropped out due to protocol violation.

^b One dropped out due to protocol violation.

Based on their findings, Chaudhuri and Marchio also concluded that bakuchiol is a multitasking product for mitigating acne-affected skin. It works by down-regulating 5 α -reductase; inhibiting, if not killing, *P. acne* and other bacteria and fungus present in acne-affected skin; quenching radicals and non-radicals, especially inhibiting lipid peroxidation; reducing pro-inflammatory activity; and inhibiting matrix metalloprotease activity. Interestingly, these authors also reported that tazarotene-inducible gene 1 (TIG1) is significantly up-regulated by both bakuchiol and retinol (see Table 1.1), and the expression of TIG1 is found to be down-regulated in a variety of human cancers as well as acne, rosacea, and psoriasis. Thus, it is quite conceivable to assume that the up-regulation of TIG1 gene by bakuchiol may provide a solution to many skin problems in addition to acne.²³

Skin Lightening and Even Toning

Photoaging is also associated with a dysregulation in melanin synthesis and distribution and with a general increase in the inflammatory status of the skin leading to the appearance of brown spots and an increase in skin redness. Recently, bakuchiol was shown to inhibit melanin production in a dose-dependent manner without showing strong cytotoxicity.¹⁴ The results of that study, which included a comparison to arbutin, a known skin lightening agent, are summarized in Table 1.10. As noted, bakuchiol showed more than a 10-fold increase in activity as compared to arbutin.

These authors' findings also indicated that the addition of bakuchiol to the cells prior to stimulation with α -MSH markedly decreased the production of melanin in a dose-dependent manner. By applying the bakuchiol prior to α -MSH stimulation, the authors effectively showed that, at least in this regard, the effect is not due to tyrosinase inhibition: the primary mode of action of arbutin and other key skin whitening agents. Independently, Chaudhuri found that bakuchiol and retinol are very weak tyrosinase inhibitors. At 10 μ g/mL level, bakuchiol and retinol have shown tyrosinase (mushroom) inhibitory activity of about 10% and 25%, respectively. EC₅₀ could not be determined due to cytotoxicity at higher doses.

It has also been found that human skin exposed to UVB irradiation with a dose of 2 MED manifests a significant increase in the expression of Endothelin-1 (ET-1) and tyrosinase mRNA signals five days after irradiation.⁶¹ In these studies, low levels of ET-1 secreted by keratinocytes in response to UVB radiation was shown to down-regulate E-cadherin in melanocytic cells. ET-1 is a potent down-regulator of E-cadherin in human melanocytes and also melanoma cells.⁶² An independent and unpublished study by Chaudhuri has shown a sixfold up-regulation of CDH-1 gene coding for E-cadherin as compared to

TABLE 1.10

Effects of Bakuchiol on Melanin Production and Cell Viability in B16 Melanoma Cells

Compounds	Melanin/EC ₅₀ in μ g/mL	Cell Viability/IC ₅₀ in μ g/mL
Bakuchiol	1.8	5.9
Arbutin	24.0	>1000

Source: Adapted from Jamal S, Schneider RJ. *J Clin Invest* 2002;110:443–52.

a control in UV-B irradiated normal human keratinocytes treated with bakuchiol using 0.5 µg/mL. In light of the foregoing, it is quite tempting to propose that bakuchiol also reduces UV-induced hyper-pigmentation by modulating E-cadherin. Additionally, in a small, open-label, pilot study by Shalita, it was found that 0.6% bakuchiol cream was effective and very well tolerated in reducing acne related post-inflammatory hyper-pigmentation. In light of the foregoing, it would seem that the combination of several skin lightening agents, targeting different pathways, may have additive or synergistic effects with bakuchiol at doses that may confer cost-effective and safe even toning as well as anti-aging effects.

Antimicrobial

Bakuchiol has shown bactericidal effects against *Streptococcus mutans*, *S. sanguis*, *S. salivarius*, *S. sobrinus*, *Enterococcus faecalis*, *E. faecium*, *Lactobacillus acidophilus*, *L. casei*, *L. plantarum*, *Actinomyces viscosus*, and *Porphyromonas gingivalis*, with minimum inhibitory concentrations (MICs) ranging from 1 to 4 µg/mL and the sterilizing concentration (15 min exposure) ranging from 5 to 20 µg/mL.²⁷ In another study, an ether extract of *P. corylifolia* seed showed antimicrobial activity against various strains of bacteria. This study concluded that the antimicrobial activity was due to the presence of bakuchiol which, among other effects, inhibited the cell growth of *S. mutans* in a concentration dependent-manner and completely prevented growth at 20 µg/mL of bakuchiol.⁶³ Similarly, an *in vitro* screening of crude methanolic seed extract of *P. corylifolia* showed significant antimycobacterial activity against *Mycobacterium aurum* and *M. smegmatis* at a MIC of 62.5 µg/mL.⁶⁴ Recently, a new source of bakuchiol was found by bioassay-guided isolation from dried leaves of *Aerva sanguinolenta* Blume and shown to have good antibacterial activity against *S. mutans*, *A. viscosus*, *S. sanguis*, and moderate antifungal activity against *Malassezia furfur*.¹⁵

Chaudhuri has also demonstrated excellent antimicrobial activities of bakuchiol in an, as yet, unpublished work. Specifically, Chaudhuri conducted an evaluation to assess the minimum inhibitory concentration values (MIC in µg/mL) of bakuchiol against various organisms relevant to personal care applications in accordance with U.S. Pharmacopeia's Compendia Products procedure for Category 2 (USP 26–87, pp. 2022–2026). The results are given in Table 1.11. The data clearly shows that bakuchiol is an effective antimicrobial ingredient for use in personal care products. Additionally, a comparative study was done of the effectiveness of several commercial antimicrobial additives against *E. coli* and *S. aureus*: the results of that study are presented in Table 1.12. As indicated, bakuchiol is comparative with, if not a superior option to, current commercial antimicrobial additives.

TABLE 1.11

Minimum Inhibitory Concentration (MIC) Values of Bakuchiol Against Various Organisms

Organisms	MIC Value (µg/mL)
Bacteria	
<i>E. coli</i>	1.0
<i>S. aureus</i>	2.0
<i>S. epidermidis</i>	1.5
<i>Streptococcus</i>	4.0
<i>Lactobacillus</i>	3.0
<i>P. gingivalis</i>	1.0
<i>P. acne</i>	1.2
<i>Pseudomonas aeruginosa</i>	8.5
Fungi	
<i>Aspergillus niger</i>	0.8
<i>Candida albican</i>	1.5
<i>P. ovale</i>	25.8

TABLE 1.12

Comparative Inhibitory Activity of Bakuchiol vs. Leading Antimicrobial Ingredients

	MIC in $\mu\text{g/mL}$	MIC in $\mu\text{g/mL}$
Ingredients	<i>S. aureus</i>	<i>E. coli</i>
Bakuchiol	2.0	1.0
Chlorhexidine	0.5–1.0	1.0
Hexachlorophene	0.5	12.5
Cetrimide	4.0	16.0
Triclosan	0.1	5.0
Benzalkonium chloride	0.5	50.0

Other Targets

Protein Tyrosine Phosphatases (PTPs)

Phosphorylation and dephosphorylation of structural and regulatory proteins are major intracellular control mechanisms in eukaryotes. PTPs are a group of enzymes that remove phosphate groups from phosphorylated tyrosine residues on proteins.³³ Protein tyrosine (pTyr) phosphorylation is a common post-translational modification that can create novel recognition motifs for protein interactions and cellular localization, affect protein stability, and regulate enzyme activity. These enzymes are key regulatory components in signal transduction pathways (such as the MAP kinase pathway) and cell cycle control, and are important in the control of cell growth, proliferation, differentiation, and transformation. As a consequence, maintaining an appropriate level of protein tyrosine phosphorylation is essential for many cellular functions.

Bioassay-guided fractionation of the EtOAc-soluble extract of the seeds of *P. corylifolia* afforded two protein tyrosine phosphatase (PTP) 1B inhibitory compounds, psoralidin and bakuchiol, along with inactive corylin. Psoralidin and bakuchiol inhibited PTP1B activity in a dose-dependent manner, displaying IC_{50} values of $9.4 \pm 0.5 \mu\text{M}$ and $20.8 \pm 1.9 \mu\text{M}$, respectively.⁶⁵ Thus, this is an area ripe for continued investigation.

DNA Polymerases

DNA polymerases are enzymes that are essential for DNA replication and are involved in a number of related cell processes, good and bad. DNA polymerase inhibitors, as their name suggests, are compounds that inhibit DNA polymerase activity. One key DNA polymerase inhibitor, resveratrol (Figure 1.2), was tested by Sun et al. and was found to have an inhibitory activity of $10 \mu\text{M}$ in an SV40 viral DNA replication assay.⁶⁶ More detailed structure–function analysis showed that resveratrol, whose structure has a 4-hydroxystyryl moiety in a trans conformation with respect to the m-hydroquinone, inhibits DNA polymerases α and δ (IC_{50} 3.3 and $5 \mu\text{M}$, respectively) and, by comparison with structurally related resveratrol derivatives, demonstrated the absolute requirement of the 4-hydroxystyryl moiety for inhibition to occur.⁶⁷ Interestingly, both corylifolin and bakuchiol also possess the 4-hydroxystyryl moiety. Additionally, bioassay-directed purification of *P. corylifolia* ethanol extracts led to the identification of corylifolin and bakuchiol as DNA polymerase inhibitors.⁶⁶ Hence, inhibition of DNA synthesis provides yet another molecular mechanism for the chemopreventive activity of bakuchiol.

Tumor Suppressor p53

Anti-tumor activity of bakuchiol was investigated on the human lung adenocarcinoma A549 cell line. MTT assay revealed that the IC_{50} of bakuchiol at 72 h was $9.58 \pm 1.12 \mu\text{mol/L}$, much more effective than

that of resveratrol ($33.02 \pm 2.35 \mu\text{mol/L}$). Bakuchiol has also been shown to reduce the mitochondrial membrane potential of cells in a concentration- and time-dependent manner. In fact, bakuchiol is shown to be more potent in many respects than resveratrol, producing/inducing a much higher level of apoptotic cells than resveratrol.²⁹ Additionally, p53 up-regulation, S phase arrest, caspase 9/3 activation, Bax up-regulation, and Bcl-2 down-regulation were observed in bakuchiol-treated A549 cells. These results suggest that S phase-related cell cycle regulation and, more importantly, reactive oxygen species-related apoptosis, might contribute to the anticancer properties of bakuchiol.

In another study, Russo et al.^{*} showed that *P. glandulosa* extracts inhibited the growth of cancer cells after 48 h of treatment (IC_{50} of $10.5 \mu\text{g/mL}$). The authors demonstrated that the extract induced apoptotic cell death, which they could attribute to the overall action of the meroterpenes present in the extract: the most active meroterpenes being bakuchiol, 12-hydroxy-iso-bakuchiol, 3-hydroxy-bakuchiol, and bakuchiol acetate. To a large extent, apoptotic cell death corresponded to a high level of DNA fragmentation, which, in turn, correlated to a significant increase in caspase-3 enzyme activity and Bax protein levels and a decrease in Bcl-2. This work supports the premise of the authors for the use of *P. glandulosa* as a potential source of anticancer agents, including, especially bakuchiol, for the treatment of melanoma.

Cellular tumor antigen p53, which is also known as phosphoprotein p53, tumor suppressor p53, and, simply p53, is a protein that, in humans, is encoded by the *TP53* gene. The p53 protein is crucial in multicellular organisms where it regulates the cell cycle and, thus, functions as a tumor suppressor, preventing cancer. As such, p53 has been described as “the guardian of the genome” because of its role in conserving stability by preventing genome mutation. In its anti-cancer role, p53 works through several mechanisms: activating DNA repair proteins when DNA has sustained damage; arresting growth by holding the cell cycle at the G₂/S regulation point on DNA damage recognition (if it holds the cell here for long enough, the DNA repair proteins will have time to fix the damage and the cell will be allowed to continue the cell cycle); and initiating apoptosis—programmed cell death—if DNA damage proves to be irreparable.⁶⁸ Thus, bakuchiol’s up-regulation of p53, as noted above, adds further support to the use of this compound in preventing and/or treating cancer.

Signal Transducer and Activator of Transcription 3(STAT3)

Inhibiting interleukin-6 (IL-6) has been postulated as an effective therapy in the pathogenesis of several inflammatory diseases. Lee et al. have shown that bakuchiol has an inhibitory effect on IL-6-induced STAT3 promoter activity in Hep3B cells with an IC_{50} value of 4.57 ± 0.45 .⁶⁹ In response to cytokines and growth factors, STAT family members are phosphorylated by receptor-associated kinases and then form homo- or heterodimers that translocate to the cell nucleus, where they act as transcription activators. STAT3 is essential for the differentiation of the TH17 helper T cells, which have been implicated in a variety of autoimmune diseases.⁷⁰

Hypoxia Inducible Factor 1 (HIF-1)

A methanol extract of the seeds of *P. corylifolia* potently inhibited hypoxia inducible factor-1 (HIF-1) activation induced by hypoxia (100% inhibition at $20 \mu\text{g/mL}$) in a HIF-1-mediated reporter gene assay.⁷¹ Interestingly, bakuchiol is the only HIF-1 inhibitory agent (IC_{50} value $6.1 \mu\text{M}$) found in this plant. In an effort to better understand the structural/performance relationship, the authors prepared few simple bakuchiol analogs and evaluated their HIF-1 inhibitory activities. Based on the results, the authors concluded that the phenolic hydroxyl group and the 12,13-double bond of bakuchiol play important roles in the biological activity of bakuchiol in HIF-1 inhibition.

HIF-1 is primarily involved in the sensing and adapting of cells to changes in the O₂ level, which is essential for their viability. A body of evidence indicates that oxygen deficiency clearly influences some major intracellular pathways such as those involved in cell proliferation, cell cycle progression, apoptosis, cell adhesion, and others.⁷¹ HIF-1 is considered a central regulator of the adaptation response

* This work was presented by A Russo et al. at the 36 Congresso Nazionale Della Societa Italiana di Farmacologia held in Torino, 2013.

of cancer cells to hypoxia that makes it a therapeutic target in solid tumors. Hypoxia may induce changes in gene expression. Many genes involved in extracellular matrix remodeling are induced by hypoxic exposure. Matrix metalloproteases (MMPs) have also been implicated in metastatic progression, because MMPs can degrade all constituents of the basement membrane as well as structural components of the stroma.⁷²

Conclusion

In summary, it is quite clear from the author's own work and the current literature that bakuchiol mimics and, in some cases, exceeds the activity of retinol towards various retinol targets and shows significant activity with respect to a number of non-retinol targets as well. Mechanistically, both the 4-hydroxystyryl and terpenic moieties of bakuchiol seem to be important, if not critical, with respect to the determination of its bioactive and physiological properties. Individual properties or effects, many of which are similar to retinol, may depend on the interplay between bakuchiol and very specific cellular targets that are upstream controllers of many cellular events. Overall, the complex and expansive biological action of bakuchiol and its capacity to modulate multiple different and distinct physiological pathways support the hypothesis of a mechanism involving multiple molecular targets. Thus, future studies on the properties of bakuchiol should evaluate the impact of bakuchiol on the maximal number of reported targets and their implications in topical as well as other modes of delivery.

REFERENCES

1. Mehta G, Nayak UR, Dev S. Monoterpenoids-I: *Psoralea corylifolia* Linn.-1. Bakuchiol, a novel monoterpene phenol. *Tetrahedron* 1973;29:1119–25.
2. Prakasarao ASC, Bhalla VK, Nayak UR et al. Monoterpenoids. II. *Psoralea corylifolia* Linn. 2. Absolute configuration of (+)-bakuchiol. *Tetrahedron* 1973;29:1127–30.
3. Sukh D, Prakasa ASA, Bhalla VK et al. Monoterpenoids-II, *Psoralea corylifolia*—2. Absolute configuration of (+)-bakuchiol. *Tetrahedron* 1972;29:1127–30.
4. Damodaran NP, Dev S. Monoterpenoids-III: *Psoralea corylifolia* linn.-3. Synthesis of (±)-bakuchiol methyl ether. *Tetrahedron* 1973;29:1209–13.
5. Banerji A, Chintalwar GJ. Biosynthesis of bakuchiol, a monoterpene from *Psoralea corylifolia*. *Phytochemistry* 1983;22(9):1945–7.
6. Banerji A, Chintalwar GJ. Biosynthesis of bakuchiol from cinnamic and p-coumaric acids. *Phytochemistry* 1984;23(9):1605–6.
7. Uikey SK, Yadav AS, Sharma AK et al. The botany, chemistry, pharmacological and therapeutic application of *Psoralea corylifolia* L.—A review. *Intern J Phytomed* 2010;2:100–7.
8. Chopra B, Dhingra AK, Dhar KL. *Psoralea corylifolia* L. (Buguchi)—Folklore to modern evidence: Review. *Fitoterapia* 2013;90:44–56.
9. Labbe C, Faini F, Coll J et al. Bakuchiol derivatives from the leaves of *Psoralea glandulosa*. *Phytochemistry* 1996;42:1299–303.
10. Backhouse CN, Delporte CL, Negrete RE et al. Active constituents isolated from *Psoralea glandulosa* L. with anti-inflammatory and antipyretic activities. *J Ethnopharmacol* 2001;78:27–3.
11. Lystvan K, Belokurova V, Sheludko Y et al. Production of bakuchiol by *in vitro* systems of *Psoralea drupacea* Bge. *Plant Cell Tiss Organ Cult* 2010;101:99–103.
12. Choi SY, Lee S, Choi WH. Isolation and anti-inflammatory activity of bakuchiol from *Ulmus davidiana* var. *japonica*. *J Med Food* 2010;13:1019–23.
13. Krenisky JM, Luo J, Reed MJ et al. Isolation and antihyperglycemic activity of bakuchiol from *Otholobium pubescens* (Fabaceae), a Peruvian medicinal plant used for the treatment of diabetes. *Biol Pharm Bull* 1999;22:1137–40.
14. Ohno O, Watabe T, Nakamura K et al. Inhibitory effects of bakuchiol, bavachin and isobavachalcone isolated from *Piper longum* on melanin production in B16 mouse melanoma cells. *Biosci Biotechnol Biochem* 2010;74(7):1504–6.

15. Rao GV, Kandaswamy K, Gopalakrishnan M. Isolation and characterization of a potent antimicrobial compound from *Aerva sanguinolenta* Blume: An alternative source of bakuchiol. *J Pharm Res* 2012;5(1):174–6.
16. Cornforth JW. Terpenoid biosynthesis. *Chem Br* 1968;4(3):102–6.
17. Geris R, Simpson TJ. Meroterpenoids produced by fungi. *Nat Prod Rep* 2009;26:1063–94.
18. Menna M, Imperatore C, D’Aniello F et al. Meroterpenes from marine invertebrates: Structures, occurrence, and ecological implications. *Mar Drugs* 2013;11:1602–43.
19. Pirola L, Frojdo S. Resveratrol: One molecule, many targets. *IUBMB Life* 2008;60(5):323–32.
20. Adhikari S, Joshi R, Patro BS et al. Antioxidant activity of bakuchiol: Experimental evidences and theoretical treatments on the possible involvement of the terpenoid chain. *Chem Res Toxicol* 2003;16:1062–9.
21. Haraguchi H, Inoue J, Tamura Y et al. Antioxidative components of *Psoralea corylifolia* (Leguminosae). *Phytother Res* 2002;16:539–44.
22. Haraguchi H, Inoue J, Tamura Y et al. Inhibition of mitochondrial lipid peroxidation by bakuchiol, a meroterpene from *Psoralea corylifolia*. *Planta Med* 2000;66:569–71.
23. Chaudhuri RK, Marchio F. Bakuchiol in the management of acne-affected skin. *Cosmetics & Toiletries* 2011;126:502–10.
24. Ferrandiz ML, Gil B, Sanz MJ et al. Effect of bakuchiol on leukocyte functions and some inflammatory responses in mice. *J Pharm Pharmacol* 1996;48(9):975–80.
25. Pae HO, Cho H, Oh GS et al. Bakuchiol from *Psoralea corylifolia* inhibits the expression of inducible nitric oxide synthase gene via the inactivation of nuclear transcription factor- κ B in RAW 264.7 macrophages. *Int Immunopharmacol* 2001;1:1849–55.
26. Matsuda H, Kiyohara S, Sugimoto S et al. Bioactive constituents from Chinese natural medicines. XXXIII. Inhibitors from the seeds of *Psoralea corylifolia* on production of nitric oxide in lipopolysaccharide-activated macrophages. *Biol Pharm Bull* 2009;32:147–9.
27. Katsura H, Tsukiyama RI, Suzuki A et al. In vitro antimicrobial activities of bakuchiol against oral microorganisms. *Antimicrob Agents Chemother* 2001;45:3009–13.
28. Pandey U, Bapat K, Samuel G et al. Bioevaluation studies of 125I-bakuchiol in tumor bearing animals. *BARC News Letter* 2007;285:88–91.
29. Chen Z, Jin K, Gao L et al. Anti-tumor effects of bakuchiol, an analogue of resveratrol, on human lung adenocarcinoma A549 cell line. *Eur J Pharmacol* 2010;643(2–3):170–9.
30. Fang J, Xin-rui Z, Qi W et al. Cytotoxic effect and mechanism of bakuchiol and bakuchiol combined with psoralen on HK-2 cell. *Int J Automation and Comput* 2010;24:50–8.
31. Cho H, Jun JY, Song EK et al. Bakuchiol: A hepatoprotective compound of *Psoralea corylifolia* on taurine-induced cytotoxicity in Hep G2 cells. *Planta Med* 2001;67:750–1.
32. Park E, Zhao YZ, Kim YC et al. Bakuchiol-induced caspase-3-dependent apoptosis occurs through c-Jun NH₂-terminal kinase-mediated mitochondrial translocation of Bax in rat liver myofibroblasts. *Eur J Pharmacol* 2007;559:115–23.
33. Sun NJ, Woo SH, Cassady JM et al. DNA polymerase and topoisomerase II inhibitors from *Psoralea corylifolia*. *J Nat Prod* 1998;61:362–6. Erratum in: *J Nat Prod* 2003;66:734.
34. Fisher GJ, Voorhees JJ. Molecular mechanism of retinoid actions in skin. *FASEB J* 1996;10(9):1002–13.
35. Chaudhuri RK. The miracle of retinol. *Soap Perfumery Cosmetics* June 10, 2010;2–24.
36. Chaudhuri RK, Bojanowski K. Bakuchiol. A retinol-like functional compound revealed by gene expression profiling and clinically proven to have anti-aging effects. *Int J Cosmet Sci* 2014;36(3):221–30.
37. Nijveldt RJ, van Nood E, van Hoorn DEC et al. Flavonoids: A review of probable mechanisms of action and potential applications. *Am J Clin Nutr* 2001;74(4): 418–25.
38. Adhikari S, Kavirayani Priyadarsini KI, Mukherjee T. Physico-chemical studies on the evaluation of the antioxidant activity of herbal extracts and active principles of some Indian medicinal plants. *J Clin Biochem Nutr* 2007;40(3):174–83.
39. Kim KA, Shim SH, Ahn HR et al. Protective effects of the compounds isolated from the seed of *Psoralea corylifolia* on oxidative stress-induced retinal damage. *Toxicol Appl Pharmacol* 2013;269(2):109–20.
40. Auffray B. Protection against singlet oxygen, the main actor of sebum squalene peroxidation during sun exposure, using *Commiphora myrrha* essential oil. *Int J Cosmetic Sci* 2017;29(1):23–9.
41. Tsujimoto Y, Shimizu S. Role of the mitochondrial membrane permeability transition in cell death. *Apoptosis* 2007;12(5):835–40.

42. Seo E, Oh YS, Kim D et al. Protective role of *Psoralea corylifolia* L. seed extract against hepatic mitochondrial dysfunction induced by oxidative stress or aging. *Evid Based Complement Altern Med* 2013; article ID 678028:9.
43. Long DJ, Waikel RL, Wang XJ et al. NAD(P)H:quinone oxidoreductase 1 deficiency increases susceptibility to benzo(a)pyrene-induced mouse skin carcinogenesis. *Cancer Res* 2000;60(21):5913–5.
44. Aggarwal BB, Shishodia S, Sandur SK et al. Inflammation and cancer: How hot is the link? *Biochem Pharmacol* 2006;72:1605–21.
45. Judson BL, Miyaki A, Kekatpure VD et al. UV radiation inhibits 15-hydroxyprostaglandin dehydrogenase levels in human skin: Evidence of transcriptional suppression. *Cancer Prevention Res* (Philadelphia, Pa.) 2010;3(9):1104–11.
46. Hruza LL, Pentland AP. Mechanisms of UV-induced inflammation. *J Invest Dermatol* 1993;100(1):35S–41S.
47. Griffiths CEM, Russman AN, Majmudar G et al. Restoration of collagen formation in photodamaged human skin by tretinoin (retinoic acid) *N Engl J Med* 1993;329:530–5.
48. Griffiths CEM. The role of retinoids in the prevention and repair of aged and photoaged skin. *Clinical and Exper Dermatol* 2001;26(7):613–8.
49. Fisher GJ, Varani J, Voorhees JJ. Looking older. Fibroblast collapse and therapeutic implications. *Arch Dermatol* 2008;144(5):666–72.
50. Fisher GJ, Wang ZQ, Datta SC et al. Pathophysiology of premature skin aging induced by ultraviolet light. *N Engl J Med* 1997;337:1419–28.
51. Varani J, Warner RL, Gharaee-Kermani M et al. Vitamin A antagonizes decreased cell growth and elevated collagen-degrading matrix metalloproteases and stimulates collagen accumulation in naturally aged human skin. *J Invest Dermatol* 2000;114:480–6.
52. Woodley DT, Zelickson AS, Briggaman RA et al. Treatment of photoaged skin with topical tretinoin increases epidermal–dermal anchoring fibrils. A preliminary report. *JAMA* 1990;263:3057–9.
53. Watson REB, Craven NM, Kang S et al. A short-term screening protocol, using fibrillin-1 as a reporter molecule, for photoaging repair agents. *J Invest Dermatol* 2001;116:672–8.
54. McCallion R, Po ALW. Dry and photo-aged skin: Manifestations and management. *J Clin Pharm Ther* 1993;18:15–32.
55. Tunggal JA, Helfrich I, Schmitz A et al. Role of E-cadherin. *EMBO J* 2005;24:1146–56.
56. Li J, Tang H, Hu X et al. Aquaporin-3 gene and protein expression in sun-protected human skin decreases with skin ageing. *Australas J Dermatol* 2010;51(2):106–12.
57. Kurokawa I, Danby FW, Ju Q et al. New developments in our understanding of acne pathogenesis and treatment. *Exp Dermatol* 2009;18:821–32.
58. Lee WJ, Jung HD, Chi SG. Effect of dihydrotestosterone on the upregulation of inflammatory cytokines in cultured sebocytes. *Arch Dermatol Res* 2010;302(6):429–33.
59. Bowe WP, Logan AC. Clinical implications of lipid peroxidation in acne vulgaris: Old wine in new bottles. *Lipids Health Dis* 2010;9:141.
60. Tan JKL. Current measures for the evaluation of acne severity. *Expert Rev Dermatol* 2008;3(5): 595–603.
61. Imokawa G, Kobayashi T, Miyagishi M et al. The role of endothelin-1 in epidermal hyperpigmentation and signaling mechanisms of mitogenesis and melanogenesis. *Pigment Cell Res* 1997;10(4):218–28.
62. Jamal S, Schneider RJ. UV-induction of keratinocyte endothelin-1 downregulates E-cadherin in melanocytes and melanoma cells. *J Clin Invest* 2002;110:443–52.
63. Yin S, Fan CQ, Wang Y et al. Antibacterial prenylflavone derivatives from *Psoralea corylifolia* and their structure–activity relationship study. *Bioorg Med Chem* 2004;12:4387–92.
64. Newton SM, Lau C, Gurcha SS et al. The evaluation of forty-three plant species for *in vitro* antimycobacterial activities; isolation of active constituents from *Psoralea corylifolia* and *Sanguinaria canadensis*. *J Ethnopharmacol* 2002;79:57–67.
65. Kim YC, Oh H, Kim BS et al. *In vitro* protein tyrosine phosphatase 1B inhibitory phenols from the seeds of *Psoralea corylifolia*. *Planta Med* 2005;71(1):87–9.
66. Sun NJ, Woo SH, Cassady, JM et al. DNA polymerase and topoisomerase II inhibitors from *Psoralea corylifolia*. *J Nat Prod* 1998;61:362–6.
67. Stivala, LA, Savio, M, Carafoli et al. Specific structural determinants are responsible for the antioxidant activity and the cell cycle effects of resveratrol. *J Biol Chem* 2001;276:22586–94.

68. Miyashita T, Krajewski S, Krajewska M et al. Tumor suppressor p53 is a regulator of bcl-2 and bax gene expression *in vitro* and *in vivo*. *Oncogene* 1994;9(6):1799–1805.
69. Lee SW, Yun BR, Kim MH et al. Phenolic compounds isolated from *Psoralea corylifolia* inhibit IL-6-induced STAT3 activation. *Planta Med* 2012;78(9):903–6.
70. Yang XO, Panopoulos AD, Nurieva R et al. STAT3 regulates cytokine-mediated generation of inflammatory helper T cells. *J Biol Chem* 2007;282(13):9358–63.
71. Wouters A, Pauwels B, Lardon F et al. Review: Implications of *in vitro* research on the effect of radiotherapy and chemotherapy under hypoxic conditions. *Oncologist* 2007;12(6): 690–712.
72. Wu CZ, Hong SS, Cai XF et al. Hypoxia-inducible factor-1 and nuclear factor-kB inhibitory meroterpene analogues of bakuchiol, a constituent of the seeds of *Psoralea corylifolia*. *Bioorg Med Chem Lett* 2008;18:2619–23.

2

Cutaneous Applications of Caffeine

Andrea M. Hui, Jared R. Jagdeo, Neil Brody, and Reena Rupani

Introduction

Caffeine has recently become popular as a component of topical cosmeceuticals due to its well-known biological activity. It has many effects on the skin including antioxidant properties, its well-documented ability to protect cells against ultraviolet (UV)-induced non-melanoma skin cancers, and anti-inflammatory properties. All of these qualities support the use of caffeine as an effective anti-aging cosmeceutical.

Background

Caffeine is a naturally occurring alkaloid. It is found in leaves, seeds, and fruits, and acts as a central nervous system stimulant and pesticide, killing insects that feed on the plants while rewarding pollinators. Caffeine is probably best known as a stimulant in coffee, tea, and other drinks. Over 80% of American adults consume coffee on a daily basis in order to avoid drowsiness, stay alert, and increase focus.¹ In coffee, caffeine is extracted from the seed of the coffee plant, *Coffea arabica*, which is found natively in the mountains of Ethiopia. Caffeine may also be extracted from the tea leaves of *Camellia sinensis*, in addition to antioxidant polyphenols.

Caffeine is a methylxanthine and is similar in structure to cyclic adenosine monophosphate (cAMP) and adenosine. After ingestion, caffeine is absorbed by the gastrointestinal tract and transported to the central nervous system via the bloodstream. Crossing the blood-brain barrier, caffeine binds to adenosine A1 and A2 receptors, which then cause the release of neurotransmitters such as acetylcholine, dopamine, noradrenaline, and serotonin, among others, all of which improve concentration and mood.^{2,3} Additionally, caffeine inhibits phosphodiesterase (PDE) activity; PDE is responsible for degradation of cyclic adenosine monophosphate (cAMP). With the inhibition of PDE, serum levels of cAMP increases, which subsequently increases blood pressure.²

Caffeine is metabolized by the cytochrome P450 oxidase system in the liver. Ninety percent of caffeine is broken down into three dimethylxanthines, which all have different functions: paraxanthine (increases the rate of lipolysis), theobromine (a vasodilator), and theophylline (bronchial smooth muscle relaxer).² The remaining caffeine (10%) is then excreted by the kidneys in an unchanged form.⁴

The systemic effects of caffeine on the human body have been well-studied. However, its mechanisms of action and effects on human skin are less well-understood. Caffeine has become increasingly popular as an additive in topical skin cosmeceuticals for the purpose of improving the appearance of skin by offering antioxidant and anticarcinogenic properties. It is, therefore, important to elucidate some of these mechanisms in order to better understand the effects of caffeine on the skin.

Clinical Uses

Caffeine and Skin Barrier Penetration

The ability of any cosmeceutical to penetrate the skin barrier is essential to its ability to affect the processes and metabolism of cells. Caffeine is able to penetrate the skin barrier well. Tuitou et al.

demonstrated that 24 h after application to human skin, quantitative skin autoradiography found that the greatest concentration of caffeine (280 $\mu\text{g}/\text{tissue}$) was found in the epidermis, while the lowest concentration (50 $\mu\text{g}/\text{tissue}$) was found in the dermis. Studies have shown that caffeine can penetrate human skin at $2.24 \pm 1.43 \mu\text{g}/\text{cm}^2/\text{h}$, with maximal absorption at 100 min after application.^{5,6} Caffeine penetration was unaffected by skin thickness or occlusion.^{5,7}

Prevention of Non-Melanoma Skin Cancers

The consumption of caffeine by humans in coffee and tea has been associated with a lowered incidence of non-melanoma skin cancers in several animal and human studies. Non-melanoma skin cancer is the most common type of cancer in the United States, with more than two million new cases diagnosed in 2012.⁸ Although mortality is low with fewer than 1000 deaths per year in the United States, morbidity and treatment costs can be significant.

Several animal models have demonstrated evidence that caffeine helps to prevent the development of non-melanoma skin cancers.^{9–12} In a mouse study by Conney et al.,¹³ SKH-1 hairless mice were treated with UVB radiation twice weekly for 20 weeks to induce papillomas, keratoacanthomas, and squamous cell carcinomas. This mouse model was meant to mimic the chronic UV exposure that humans receive early in life, which increases the risk of developing skin cancers later. In this study by Conney et al.,¹³ skin cancers in the mice were found many months after exposure to UV irradiation. When caffeine was administered orally or topically, it significantly inhibited the development of UVB-induced focal hyperplasia and skin cancer development in these mice. Topical application of caffeine (1.2 mg in 100 μL acetone) five days per week for six weeks after stopping UVB exposure to these mice induced apoptosis of UV-induced tumors. All topical applications were well-tolerated by the mice without adverse effects.

Additionally, twice daily application of caffeine for 3–14 days to this UVB-irradiated mouse model enhanced selective apoptosis of focal basal cell hyperplastic areas of the epidermis, which are considered a marker of early skin tumor formation. Apoptosis was measured by looking for caspase-3-positive cells in the mouse epidermis after treatment was complete. Topical caffeine caused apoptosis in 68%–74% of focal basal cell hyperplastic areas of the epidermis as compared with control alone. Oral administration of 0.6% green tea stimulated apoptosis in 89% of these hyperplastic areas in mouse epidermis. In an additional study by this group, topical application of caffeine for several months to these high-risk SKH-1 hairless mice did not demonstrate apoptosis in areas that did not contain a tumor, confirming that caffeine induced selective apoptosis in UVB-irradiated skin only.¹³

In additional mouse studies by Conney et al.,¹³ topically applied caffeine just prior to UVB irradiation was shown to have a sunscreen effect as measured by the inhibition of UVB-induced thymine dimers. Specifically, female SKH-1 mice were treated with a single topical application of caffeine or caffeine sodium benzoate (24.8 μmol) in 100 mg of Dermabase (commercial cream) 30 min prior to UVB irradiation. Topical caffeine resulted in 71% inhibition, while topical caffeine sodium benzoate had an even greater sunscreen effect at 90% inhibition of UVB-induced thymine dimers. A single topical application of the same concentrations of caffeine or caffeine sodium benzoate in 100 mg Dermabase cream immediately after UVB irradiation was also highly effective in inducing selective apoptosis of UVB-pretreated SKH-1 mice, while Dermabase cream alone was inactive.

Abel et al. conducted a large cross-sectional human epidemiological study to determine the relationship between daily coffee consumption and the development of non-melanoma skin cancers.¹⁴ They evaluated a total of 93,676 postmenopausal Caucasian women enrolled in the Women's Health Initiative (WHI) Observational Study between 1993 and 1998 in over 40 clinical centers throughout the United States. These women were of diverse ethnic background. Women who had consumed caffeinated coffee on a daily basis had a 10.8% lower incidence of non-melanoma skin cancers compared with women who drank decaffeinated coffee. In fact, there was a dose-dependent decrease in the incidence of skin cancer; women who had six or more cups of caffeinated coffee demonstrated a 36% decrease in the incidence of non-melanoma skin cancers. Each additional cup of caffeinated coffee conferred a 5% decrease in the development of non-melanoma skin cancers. After adjusting for confounding factors associated with the

development of non-melanoma skin cancers, demographics, and other variables, daily caffeinated coffee consumption was associated with a reduction of 30% in the prevalence of non-melanoma skin cancers in a dose-dependent manner.

In a similar prospective study, Song et al.¹⁵ demonstrated that there was a significant inverse between caffeine consumption (from all dietary sources) and risk of developing basal cell carcinomas (BCCs). The data was gathered from the Nurses' Healthy Study and the Health Professionals Follow-up Study, a self-administered questionnaire studying the risk factors for cancer and cardiovascular disease, which was established in 1976 with 121,700 respondents. This study demonstrated that caffeine worked in a dose-dependent manner, as those subjects who consumed more than three cups of coffee per day had the lowest risk of developing BCCs. Decaffeinated coffee consumption was not associated with a similar BCC risk reduction. Of note, caffeine intake was not associated with any decrease in the risk of melanoma or squamous cell carcinoma.

There are several proposed mechanisms of action for the role of caffeine in the inhibition of non-melanoma skin cancer formation. In a mouse study by Lu et al.,¹⁶ topical application of caffeine has been shown to selectively induce apoptosis in UV-damaged keratinocytes and squamous cell carcinomas without affecting surrounding normal skin. This selective apoptosis did not require activation of p53; in fact, keratinocytes with p53 mutations were selectively destroyed after caffeine was applied topically.¹³ Additionally, in a study by Conney et al.,¹³ oral administration of caffeine (0.4 mg/mL) to high-risk UVB-irradiated SKH-1 mice inhibited the formation of mutant p53-positive patches of epidermis by 40% when compared with a control. Finally, in an *in vitro* study by Heffernan et al., administration of caffeine to human keratinocytes demonstrated an increase in UVB-induced apoptosis via an ATR-checkpoint kinase (Chk) 1 pathway but not via a cyclic AMP pathway.¹⁷ With inhibition of the ATR-Chk1 pathway, caffeine can then prevent tumor growth and promote apoptosis. All of these mechanisms work together to help explain the role of caffeine in the prevention of non-melanoma skin cancers.

Antioxidant Properties of Caffeine

Ultraviolet radiation generates reactive oxygen species (ROS) and hydrogen peroxide (H₂O₂), which can cause damage to DNA, RNA, lipids, and proteins, all of which can cause cell death. ROS is a well-known inducer of skin carcinogenesis and UV-induced aging and inflammation. In addition to UV radiation, ROS is generated by other environmental factors such as pollution and smoking. ROS is also generated by normal metabolic processes such as cytochrome P450 cycling¹⁸ and lipid peroxidation,¹⁹ allowing free ROS to cause oxidative damage to cells within the body.

There has been increasing interest in finding effective topical antioxidants to help to prevent ROS-induced oxidative damage to the skin. In an *in vitro* study by Silverberg et al.,²⁰ human skin fibroblasts were pre-treated with caffeine in varying concentrations (1, 0.1, and 0.01 mM) for 4 hours and then subjected to incubation with H₂O₂ (1.2 mM) for 30 or 120 min, or no H₂O₂ as a control. Pretreatment with caffeine protected against fibroblast necrosis, which was induced by 30 min of exposure to H₂O₂. Fibroblast cell numbers were increased as well. Thirty or 120 min of exposure to H₂O₂ caused visible changes to the morphology of the fibroblasts, causing them to become smaller and more irregular, which indicated impending necrosis. Pretreatment with caffeine significantly improved cell morphology. Interestingly, the antinecrotic effects of caffeine were associated with increased ROS production at 30 min and decreased ROS production at 120 min. These results indicated that the antinecrotic effects of caffeine were related to effects other than being an antioxidant, as reviewed earlier.

Reduction in Facial Redness

The causes of facial redness are multifactorial. Redness is often associated with inflammatory dermatoses such as rosacea, atopic dermatitis, and psoriasis. Most commonly, epidermal barrier dysfunction can exacerbate inflammation and it is often worsened with variations in the humidity of the environment,

especially during winter and in arid climates.²¹ When the skin barrier is disrupted, pre-formed pro-inflammatory cytokines within keratinocytes, such as interleukin 1 α (IL-1 α), are released immediately. IL-1 α then upregulates the release of many other pro-inflammatory cytokines, causing an inflammatory cascade. Additionally, it has been shown that free radicals also play a role in the development of inflammatory dermatoses.²²

Angiogenesis can also contribute to facial redness. An increase in the number of blood vessels present in skin and altered vessel permeability can increase facial redness by allowing more pro-inflammatory cytokines and molecules to reach the skin surface. It has been shown that the pretreatment of human colon cancer cells with caffeine significantly reduced the activity of adenosine-induced vascular endothelial growth factor (VEGF) promoter activity and subsequent expression of VEGF and IL-8 *in vitro*.²³ In a split-face *in vivo* study by Ferzli et al.,²⁴ a topical combination of antioxidants containing resveratrol, green tea polyphenols, and caffeine was applied to subjects (n = 16) twice daily for 12 weeks. Reduction in facial redness was significant and noted by at least week 6 and tolerated well by all subjects. It is now a commercially available product.

Anti-Cellulite

Cellulite is the dimpled, “orange peel,” or “cottage cheese” appearance of skin, often occurring in the pelvic, abdominal, and leg areas of women. It affects 85%–95% of post-pubertal women of all ethnicities.^{25,26} It is a cause of great cosmetic concern. The causes of cellulite are multifactorial. In general, genetics, hormonal factors, alteration of connective tissue structure, fibrosis, and insufficiency of the microcirculatory and lymphatic system all play a role in causing cellulite.

There are several mechanisms whereby caffeine imparts its anti-cellulite effect. Caffeine stimulates lipolysis, which is the degradation of triglycerides from adipocytes by lipoprotein lipases. Lipases are located on the adipocyte membrane and are controlled by levels of catecholamines and hormones.^{27,28} Caffeine has been shown to enhance lipolysis by increasing secretion of catecholamines, which activate β -adrenergic receptors. This increases the concentration of intracellular cAMP and activates hormone-sensitive lipase, causing lipolysis.²⁹ Additionally, caffeine can block α -adrenergic receptors, which helps to prevent excess accumulation of fats as well as encourage lipolysis.^{30,31} Additionally, caffeine can stimulate lipolysis by inhibiting PDE activity, which also increases cAMP levels in adipocytes.³¹ Finally, caffeine can improve the microcirculation of blood vessels, which can also improve the appearance of cellulite by increasing the flow of oxygen and alleviating compression of vessels. All of these mechanisms break down adipocytes and can reduce the appearance of cellulite.

In an animal study by Pires-de-Campos et al.,³² a caffeine gel (5% in water), caffeine gel with ultrasound treatment, and control gel with ultrasound treatment was applied daily to pig skin for 15 days. Only caffeine gel with ultrasound treatment revealed a significant reduction in the thickness of subcutaneous fat, damage to adipocytes, and a decrease in the number of adipocytes.

An improvement in microcirculation can also improve the appearance of cellulite. Insufficiency of microcirculation and compression of vessels can cause tissue hypoxia, which leads to an alteration in aerobic glucose metabolism and a subsequent increase in lactic acid production. Alteration of aerobic glucose metabolism can also lead to activation of proline hydroxylase, which produces procollagen and collagen, therefore leading to fibrosis of tissue and the appearance of cellulite.³³

An *in vivo* study by Lupi et al.³⁴ sought to determine the efficacy of a 7% caffeine solution to treat cellulite by measuring changes in perivascular dermal edema and diameter of thighs and hips. One hundred and thirty-four women applied the solution twice daily for 30 days to one leg at a dose of 15 mL per leg. At the end of the 30-day treatment, a significant reduction in circumference of the treated leg, specifically the lower thigh, was noticed in 80.8% of the subjects when compared with untreated legs. The median circumference reduction in the thigh was 2.1 cm. Interestingly, 67.7% of patients demonstrated a reduction in the circumference of the hip after the treatment period. Microcirculation was measured using a noninvasive spectral imaging technique, which determined capillary density; the microcirculatory blood flow was improved in all women who applied the topical caffeine solution.

Hair Growth

Alopecia is a loss of hair from the scalp or body. Male pattern baldness, or androgenetic alopecia, is responsible for more than 95% of alopecia in men.³⁵ It is well known that the hair follicles of the vertex of the scalp are especially sensitive to dihydrotestosterone (DHT), which is produced when 5- α -reductase converts testosterone to DHT. Genetics play a role in hair follicle sensitivity to DHT. DHT shortens the anagen (growth) phase of the hair cycle, leading to premature telogen phase with miniaturization of hair and a reduction in the number of hair roots. Newly growing hair subsequently becomes thinner and after a finite number of growth cycles, hair ceases to grow.

Topical caffeine is able to effectively penetrate the scalp into the hair follicles.³⁶ A study by Otberg et al.³⁷ showed that two minutes of contact with a 2% caffeine-containing shampoo was sufficient to allow penetration of caffeine into the hair follicle and remain detectable for 48 h and also after washing of the hair. Caffeine was found in the bloodstream within five minutes of application at a concentration of 3.75 ng/mL; if the follicles were blocked with wax, caffeine was detectable after 20 minutes at a concentration of 2.24 ng/mL. Interestingly, the highest concentration of caffeine at 11.75 ng/mL was found 1 hour after short-contact application when follicles were left unblocked.

Caffeine has been shown to inhibit the activity of 5- α -reductase, prolonging the anagen phase and increasing hair growth. In a study by Fischer et al.,³⁸ hair follicles were taken from 14 biopsies of the vertex scalp in men with androgenetic alopecia. These hair follicles were cultured *in vitro* for 120–192 hours in a medium containing varying concentrations of testosterone to suppress hair growth and/or caffeine versus a control. Caffeine concentrations ranged from 0.001%–0.15%. Hair shaft elongation was measured daily. At the end of the study, caffeine alone led to significant stimulation of hair growth, despite suppression with testosterone.

There may be other mechanisms by which caffeine may stimulate hair growth. As discussed earlier, it is able to inhibit phosphodiesterase, resulting in an increase of cAMP levels and stimulation of cell metabolism, which would therefore prevent DHT-induced hair follicle miniaturization.³⁸ Additionally, by improving microcirculation, caffeine can possibly improve oxygenation and increase the delivery of nutrients to the scalp.

Future Applications of Topical Caffeine

Caffeine has shown promise for the treatment of the aforementioned conditions. Combinations of caffeine plus other cosmeceuticals may offer synergistic mechanisms of action. For example, topical minoxidil is a well-known over-the-counter treatment for androgenetic hair loss, which provides growth through many mechanisms including vasodilation. Combination with caffeine may provide further improvement of microcirculation and increase of cAMP levels, which may enhance the beneficial effects of minoxidil. Additionally, topical caffeine can be easily added to sunscreens or other antioxidant cosmeceuticals to provide further protection against the development of non-melanoma skin cancers (NMSCs). There are several topical products already available, as shown in [Table 2.1](#).

Conclusion

Caffeine is gaining popularity as a component of topical anti-aging products for its properties in preventing skin cancer, an antioxidant, and reduction of redness. Its effects have been elucidated in this chapter (and are outlined in [Table 2.2](#)).

There are many other potential cosmetic uses of caffeine, so more research must be conducted to determine its full potential and develop an optimal delivery system to the skin.

TABLE 2.1

Commercial Products Containing Caffeine

Manufacturer	Name	Other Featured Ingredients	Other Ingredients	Skin Type/Usage
Glytone	Anti-Aging Eye Cream	Red tea flavonoids, glycolic acid	Extracts of <i>Nymphaea alba</i> , quinoa seed, licorice	Anti-aging, antioxidant
La Roche Posay	Hydraphase Intense Eyes	HA (as sodium hyaluronate and hydrolyzed HA)	Soybean protein	Anti-puffiness, dark circle reduction, hydration
La Roche Posay	Redermic Eyes	Retinol 0.01%, retinyl linoleate, HA	Adenosine	Anti-aging, dark circle reduction
La Roche Posay	Rosaliac Anti-Redness Moisturizer	Niacinamide, vitamin E	Shea butter, palmitic acid	Redness reduction
Neocutis	Lumiere Bio-Restorative Eye cream and Riche version	Processed skin proteins (PSP), HA, human growth factors (Riche with 30% more), vitamin C	Extracts of beech tree bed and palm oil, squalene, triglycerides	Rejuvenation of eye area, anti-aging
Obagi	ELASTIderm Eye Complete Complex Serum	Flavonoids, peptides, blueberry extract	Malonic acid, copper carbonate	Rejuvenation of eye area
PCA SKIN	Protecting Hydrator Broad Spectrum SPF 30	Zinc oxide, octinoxate, octisalate	Extract of milk thistle, aloe vera, panthenol, silybin	All skin types; sun protection
SkinMedica	Daily Physical Defense SPF 30	Green tea, ceramides, HA	Zinc oxide, titanium dioxide	All types including post-procedure
SkinCeuticals	A.G.E. Eye Complex	Bi-mineral complex (copper, zinc), vitamin E	Extract of <i>Vaccinium Myrtillus</i> , malonic acid	Anti-aging, depuffing
SkinCeuticals	Phloretin CF Gel	Phloretin, vitamin C, ferulic acid	Extract of <i>Ruscus aculeatus</i>	Prevention of photodamage, collagen stimulation
SkinCeuticals	Redness Neutralizer	Vitamin E	Squalene, zinc, shea butter extract of <i>Eperua falcata</i>	Redness reduction

(Continued)

TABLE 2.1 (Continued)

Commercial Products Containing Caffeine

Manufacturer	Name	Other Featured Ingredients	Other Ingredients	Skin Type/Usage
Topix	Replenix Power of Three cream	Resveratrol, green tea polyphenols	Soy phospholipid, extracts of soy, cucumber, chamomile, rosemary	Dry, mature Rosacea and sensitive skin Post-procedure
Topix	Replenix Cream CF	Green tea polyphenols, HA	Extracts of cucumber and chamomile	Anti-aging
Topix	Green Tea Antioxidant Moisturizing Lotion	Green tea polyphenols, HA, ceramides	Extract of yucca root, squalene	All skin types especially sensitive and dry
Topix	Replenix Serum CF	Green tea polyphenols, HA	Chamomile extract	Rosacea, sensitive skin, post-procedure
Topix	Replenix Power of Three serum	Resveratrol, green tea polyphenols	Soy phospholipid, extracts of soy, cucumber, chamomile, rosemary	Oily, acne-prone
Topix	Replenix All Trans Retinol Eye Repair Cream	Green tea polyphenols, retinol, vitamins E & K, HA	Extracts of kelp, milk thistle, Indian gooseberry, Arnica montana	Anti-puffiness, anti-aging
Topix	Replenix All Trans Retinol Smoothing Serum 2X, 3X, 5X, 10X	Green tea polyphenols, retinol, HA		Anti-aging and acne, collagen stimulation
Topix	SRS Cell Repair Therapy	Retinyl palmitate, vitamin C & E	Squalene, extracts of <i>Arabidopsis thaliano</i> , plankton, <i>Evodia rutaecarpa</i>	Anti-aging, anti-inflammatory, antioxidant
Vichy	LiftActiv Retinol HA Eyes	HA, retinyl palmitate	Shea butter, sunflower seed oil	Anti-wrinkle
Vichy	LiftActiv HA Eyes	Escine, rhamnose, vitamin E	Beeswax	Depuffing, anti-aging, dark circles, collagen stimulation
Trind	Nail Balsam	Vitamin E, phospholipids	Biotin, panthenol	Nail growth

Note: HA = hyaluronic acid; HGF = human growth factors.

TABLE 2.2

Significant Studies Investigating the Use of Caffeine

Author (year)	Study Design	# of Study Subjects	Other Interventions	Dose of Caffeine	Length of Study	Effect	Notes
Lu et al. (2004) ¹⁶	Controlled mouse study	Male or female p53 (+/+ or -/-) C57BL/6J mice	UVB irradiation (60 mJ/cm ²)	Topical application of 1.2 mg caffeine in 100 μ L acetone	One application immediately after UVB irradiation	After 6 h, selectively increases apoptosis by 127% (p53 +/+) and 563% (p53 -/-)	Topical caffeine was well tolerated
Lu et al. (2004) ¹⁶	Controlled mouse study	Male or female Bax (+/+ or -/-) C57BL/6J mice	UVB irradiation (60 mJ/cm ²)	Topical application of 1.2 mg caffeine in 100 μ L acetone	One application immediately after UVB irradiation	After 6 h, selectively increases apoptosis by 214% (Bax +/+) and 467% (Bax -/-) and increased caspase-3-positive cells by 253% (Bax +/+) and 750% (Bax -/-)	Topical caffeine was well tolerated
Heffernan et al. (2009) ¹⁷	<i>In vitro</i> study	Primary human keratinocytes	UVB irradiation (75 mJ/cm ²) and siRNA or inhibitor (PF610666) against ATR-Chk1	2 mM caffeine	One treatment 30 min before UVB irradiation	Caffeine selectively increased apoptosis of UVB-treated KC from 10% (UV only) to 24%; similar results when ATR-Chk1 was knocked out	Caffeine did not further augment apoptosis after UVB in ASTR-Chk1 knockout KC, suggesting that key target is ATR
Conney et al. (2008) ¹³	Controlled mouse study	Female SKH-1 hairless mice (7–8 weeks old, n = 30)	UVB irradiation (30 mJ/cm ² for 20 weeks) to create skin tumors	Topical application at 1.2 mg in 100 μ L acetone	5 days per week for 6 weeks	Inhibited the development of UVB-induced focal hyperplasia and skin cancer development	Topical caffeine was well tolerated
Conney et al. (2008) ¹³	Controlled mouse study	Female SKH-1 hairless mice (7–8 weeks old, n = 16 per group)	UVB irradiation (30 mJ/cm ²)	Topical application at 6.4 μ mol in 100 μ L acetone	Twice daily for 3 or 14 days	Selectively increased apoptosis (68–74% of focal basal cell hyperplastic areas) as measured by caspase-3-positive cells	Topical caffeine was well tolerated

(Continued)

TABLE 2.2 (Continued)

Significant Studies Investigating the Use of Caffeine

Author (year)	Study Design	# of Study Subjects	Other Interventions	Dose of Caffeine	Length of Study	Effect	Notes
Conney et al. (2008) ¹³	Controlled mouse study	Female SKH-1 hairless mice (7–8 weeks old, n = 10 per group)	UVB irradiation (30 mJ/cm ²)	Topical application of varying caffeine or caffeine benzoate concentrations (3.1–24.8 μmol) in 100 mg Dermabase cream	One application 30 min prior to UVB irradiation	Caffeine: 71% inhibition of UVB-induced thymine dimers Caffeine benzoate: 90% inhibition of UVB-induced thymine dimers	Topical caffeine was well tolerated
Abel et al. (2007) ¹⁴	Cross-sectional epidemiological study	93,676 postmenopausal Caucasian women	n/a	Self-reported cups of caffeinated coffee	Between 1993 and 1998	10.8% lower incidence of NMSC with daily consumption of coffee; 36% lower incidence of NMSC with 6+ daily cups of coffee	Adjusting for confounding factors, daily coffee was associated with 30% decrease in prevalence of NMSC
Song et al. (2012) ¹⁵	Prospective cohort study	121,700 registered nurses aged 30 to 55 years and 51,529 U.S. male health professionals aged 40–75 years	n/a	Self-reported cups of caffeinated coffee or caffeine from other dietary sources	Data collected from 1976	Subjects who consumed more than 3 cups of coffee per day had the lowest risk of developing BCCs, not SCC or melanoma	Caffeine from other dietary sources (tea, cola, and chocolate) were also inversely associated with BCC risk
Silverberg et al. (2012) ²⁰	<i>In vitro</i> study	Human skin fibroblasts	H ₂ O ₂ (1.2 mM) for 30 or 120 min	Caffeine in varying concentrations (1, 0.1, and 0.01 mM)	Pretreatment with caffeine for 4 h	Pretreatment with caffeine protected against fibroblast necrosis, improved H ₂ O ₂ -induced fibroblast cell numbers, and improved cell morphology	

(Continued)

TABLE 2.2 (Continued)

Significant Studies Investigating the Use of Caffeine

Author (year)	Study Design	# of Study Subjects	Other Interventions	Dose of Caffeine	Length of Study	Effect	Notes
Ferzli et al. (2013) ²⁴	Split-face study	Subjects with facial redness (n = 16)	Topical formulation also contains resveratrol and GTP	Topical formulation applied to half of face twice daily	6 weeks	Significant decrease in facial redness	Well tolerated by all subjects
Pires-de-Campos et al. (2008) ³²	Controlled pig study	5 pigs	Ultrasound therapy (3 MHz with an intensity of 0.2 W/cm ²)	Topical caffeine gel 5% w/w applied daily	15 days	Significant reduction in subcutaneous fat thickness, damage to adipocytes, and decrease in number of adipocytes	Well tolerated
Lupi et al. (2007) ³⁴	Prospective cohort study	134 women aged 20–39		15 mL topical 7% caffeine solution (Elancyl Chrono-Active [®]) to one leg twice daily	30 days	Significant reduction in leg circumference, most notable on lower thigh, in 80.8% of subjects; improved microcirculatory blood flow	Median circumference reduction was 2.1 cm
Fischer et al. (2007) ³⁸	<i>Ex vivo</i> study	Scalp biopsies taken from 14 men with androgenetic alopecia	5 µg/mL testosterone to suppress hair shaft growth	Varying concentrations from 0.001–0.15%	120–192 h	Caffeine alone significantly stimulated hair follicle growth and protected against suppression caused by testosterone	

Note: NMSC: non-melanoma skin cancer; BCC: basal cell carcinoma; SCC: squamous cell carcinoma; ATR-Chk1: ataxia-telangiectasia Rad3 – checkpoint kinase 1; UVB: ultraviolet B; H₂O₂: hydrogen peroxide; GTP: green tea polyphenols.

REFERENCES

1. USA NCA. National Coffee Drinking Trends 2013. 2013; <http://www.ncausa.org/i4a/pages/index.cfm?pageID=731>.
2. Fisone G, Borgkvist A, Usiello A. Caffeine as a psychomotor stimulant: Mechanism of action. *Cell Mol Life Sci* 2004;61(7–8):857–72.
3. Smith A. Effects of caffeine on human behavior. *Food Chem Toxicol* 2002;40(9):1243–55.
4. Burlando B VL, Cornara L, Bottini-Massa E. *Herbal Principles in Cosmetics. Properties and Mechanism of Action*. London: CRC Press; 2010.
5. van de Sandt JJ, van Burgsteden JA, Cage S et al. *In vitro* predictions of skin absorption of caffeine, testosterone, and benzoic acid: A multi-centre comparison study. *Regul Toxicol Pharmacol* 2004;39(3):271–81.
6. Zesch A, Schaefer H, Stuttgen G. The quantitative distribution of percutaneously applied caffeine in the human skin. *Arch Dermatol Res* 1979;266(3):277–83.
7. Treffel P, Muret P, Muret-D'Aniello P et al. Effect of occlusion on *in vitro* percutaneous absorption of two compounds with different physicochemical properties. *Skin Pharmacol* 1992;5(2):108–13.
8. National Cancer Institute at the National Institutes of Health. Skin Cancer. 2013; <http://www.cancer.gov/cancertopics/types/skin>.
9. Wang ZY, Agarwal R, Bickers DR et al. Protection against ultraviolet B radiation-induced photocarcinogenesis in hairless mice by green tea polyphenols. *Carcinogenesis* 1991;12(8):1527–30.
10. Wang ZY, Huang MT, Ferraro T et al. Inhibitory effect of green tea in the drinking water on tumorigenesis by ultraviolet light and 12-O-tetradecanoylphorbol-13-acetate in the skin of SKH-1 mice. *Cancer Res* 1992;52(5):1162–70.
11. Wang ZY, Huang MT, Lou YR et al. Inhibitory effects of black tea, green tea, decaffeinated black tea, and decaffeinated green tea on ultraviolet B light-induced skin carcinogenesis in 7,12-dimethylbenz[a]anthracene-initiated SKH-1 mice. *Cancer Res* 1994;54(13):3428–35.
12. Huang MT, Xie JG, Wang ZY et al. Effects of tea, decaffeinated tea, and caffeine on UVB light-induced complete carcinogenesis in SKH-1 mice: Demonstration of caffeine as a biologically important constituent of tea. *Cancer Res* 1997;57(13):2623–29.
13. Conney AH, Kramata P, Lou YR et al. Effect of caffeine on UVB-induced carcinogenesis, apoptosis, and the elimination of UVB-induced patches of p53 mutant epidermal cells in SKH-1 mice. *Photochem Photobiol* 2008;84(2):330–8.
14. Abel EL, Hendrix SO, McNeelley SG et al. Daily coffee consumption and prevalence of nonmelanoma skin cancer in Caucasian women. *Eur J Cancer Prev* 2007;16(5):446–52.
15. Song F, Qureshi AA, Han J. Increased caffeine intake is associated with reduced risk of basal cell carcinoma of the skin. *Cancer Res* 2012;72(13):3282–9.
16. Lu YP, Lou YR, Peng QY et al. Stimulatory effect of topical application of caffeine on UVB-induced apoptosis in the epidermis of p53 and Bax knockout mice. *Cancer Res* 2004;64(14):5020–7.
17. Heffernan TP, Kawasumi M, Blasina A et al. ATR-Chk1 pathway inhibition promotes apoptosis after UV treatment in primary human keratinocytes: Potential basis for the UV protective effects of caffeine. *J Invest Dermatol* 2009;129(7):1805–15.
18. Carmeia B. Molecular mechanisms in cancer induction and prevention. *Environ Health Perspect* 1993;101(Supplement 3):237–45.
19. Devasagayam TP, Kesavan PC. Radioprotective and antioxidant action of caffeine: Mechanistic considerations. *Indian J Exp Biol* 1996;34(4):291–7.
20. Silverberg JJ, Patel M, Brody N et al. Caffeine protects human skin fibroblasts from acute reactive oxygen species-induced necrosis. *J Drugs Dermatol* 2012;11(11):1342–6.
21. Wilkinson SM, Beck MH. Contact dermatitis: Irritant. In: Burns T, Breathnach S, Cox N, Griffiths C, eds. *Rook's Textbook of Dermatology*, 8th edition. Wiley-Blackwell; 2010.
22. Maccarrone M, Catani MV, Iraci S et al. A survey of reactive oxygen species and their role in dermatology. *J European Acad Dermatol Venereol* 1997;8(3):185–202.
23. Merighi S, Benini A, Mirandola P et al. Caffeine inhibits adenosine-induced accumulation of hypoxia-inducible factor-1alpha, vascular endothelial growth factor, and interleukin-8 expression in hypoxic human colon cancer cells. *Mol Pharmacol* 2007;72(2):395–406.
24. Ferzli G, Patel M, Phrsai N et al. Reduction of facial redness with resveratrol added to topical product containing green tea polyphenols and caffeine. *J Drugs Dermatol* 2013;12(7):770–4.

25. Scherwitz C, Braun-Falco O. So-called cellulite. *J Dermatol Surg Oncol* 1978;4(3):230–4.
26. Nurnberger F, Muller G. So-called cellulite: An invented disease. *J Dermatol Surg Oncol* 1978;4(3):221–9.
27. Conti M. Phosphodiesterases and cyclic nucleotide signaling in endocrine cells. *Mol Endocrinol* 2000;14(9):1317–27.
28. Cawthorn WP, Sethi JK. TNF-alpha and adipocyte biology. *FEBS Lett* 2008;582(1):117–31.
29. Diepvens K, Westerterp KR, Westerterp-Plantenga MS. Obesity and thermogenesis related to the consumption of caffeine, ephedrine, capsaicin, and green tea. *Am J Physiol Regul Integr Comp Physiol* 2007;292(1):13.
30. Panchal SK, Poudyal H, Waanders J et al. Coffee extract attenuates changes in cardiovascular and hepatic structure and function without decreasing obesity in high-carbohydrate, high-fat diet-fed male rats. *J Nutr* 2012;142(4):690–7.
31. Vogelgesang B, Bonnet I, Godard N et al. *In vitro* and *in vivo* efficacy of sulfo-carrabiose, a sugar-based cosmetic ingredient with anti-cellulite properties. *Int J Cosmetic Sci* 2011;33(2):120–5.
32. Pires-de-Campos MS, Leonardi GR, Chorilli M et al. The effect of topical caffeine on the morphology of swine hypodermis as measured by ultrasound. *J Cosmet Dermatol* 2008;7(3):232–7.
33. Rossi AB, Vergnanini AL. Cellulite: A review. *J Eur Acad Dermatol Venereol* 2000;14(4):251–62.
34. Lupi O, Semenovitch IJ, Treu C et al. Evaluation of the effects of caffeine in the microcirculation and edema on thighs and buttocks using the orthogonal polarization spectral imaging and clinical parameters. *J Cosmet Dermatol* 2007;6(2):102–7.
35. WebMD. Male Pattern Baldness. 2013; <http://www.webmd.com/skin-problems-and-treatments/hair-loss/hair-loss-introduction-mens>.
36. Lademann J, Richter H, Schanzer S et al. Analysis of the penetration of a caffeine containing shampoo into the hair follicles by *in vivo* laser scanning microscopy. *Laser Phys* 2010;20(2):551–6.
37. Otberg N, Patzelt A, Rasulev U et al. The role of hair follicles in the percutaneous absorption of caffeine. *Br J Clin Pharmacol* 2008;65(4):488–92.
38. Fischer TW, Hipler UC, Elsner P. Effect of caffeine and testosterone on the proliferation of human hair follicles in vitro. *Int J Dermatol* 2007;46(1):27–35.

3

Curcumin in Cosmetics: Biochemical Basis for Skin Repair with Use of Topical Curcumin

Madalene C.Y. Heng

Introduction

Curcumin (diferuloylmethane or 1,7-bis-[4-hydroxy-3-methoxyphenyl]-1,6-heptadiene-3,5-dione) is the active ingredient in turmeric, derived from the rhizome of *Curcuma longa*.¹ Turmeric has been used in cosmetics and medicine in the Indian subcontinent for centuries. Turmeric itself contains turmerin, essential oils and curcuminoids, including curcumin, the most biologically active of the ingredients. Curcumin comprises 2%–8% of turmeric¹ and is mainly responsible for the yellow color. The observed anti-inflammatory properties² of curcumin has led to its use as a therapeutic cosmetic. The colored curcuminoids, however, have been found to be more potent than the colorless compounds, with curcumin being the most potent of the colored curcuminoids.

The effectiveness of curcumin administered orally is hindered by its poor bioavailability due to the fact that the unconjugated curcumin molecule, which is hydrophobic, is poorly absorbed when taken orally, with very low curcumin levels detected in blood and tissues after ingestion.³ The molecule is usually absorbed by the gut as water-soluble curcumin metabolites (glucuronate or sulfate), with different anti-inflammatory properties from the unconjugated molecule. Topical curcumin is much better absorbed through the skin, particularly when the skin barrier is defective as in the presence of skin injury or disease.

An important and unique biochemical property of curcumin that makes it particularly useful for skin problems is that it is a selective and non-competitive inhibitor of phosphorylase kinase (PhK).⁴ PhK is released within minutes following skin injury, and is responsible for activating multiple signaling pathways^{5–7} involved in tissue inflammation. These may lead to scarring, dysregulated cell cycling, increased mitotic potential, and tumor promotion. The clinical manifestations of these cellular and tissue changes include thinning of the skin, pigmentary and keratotic lesions, and tumor transformation, particularly after solar injury. By inhibiting PhK, one of the earliest molecules involved in the injury pathway, curcumin blocks PhK-dependent signaling pathways, leading to mitigation of tissue injury. In this chapter, these injury processes and related signaling pathways that are targeted by curcumin will be detailed. The ability of curcumin to block these pathways may be the basis of the reparative properties of curcumin as a cosmetic, particularly in relation to anti-aging and possibly in the prevention of photocarcinogenesis in solar damaged skin.^{5,6} It may also be the basis of healing of burns and surgical wounds with minimal scarring.^{6,7} The use of topical curcumin in injured skin may, therefore, have widespread cosmetic and therapeutic implications.

Signaling Pathways Induced by Skin Injury

Sequence of Early Events in Injury: Pathways Blocked by Curcumin

The sequence of early events after a skin injury at the molecular and biochemical level has been determined from investigations on the skin and other tissues. Much has been learnt from injured tissue after

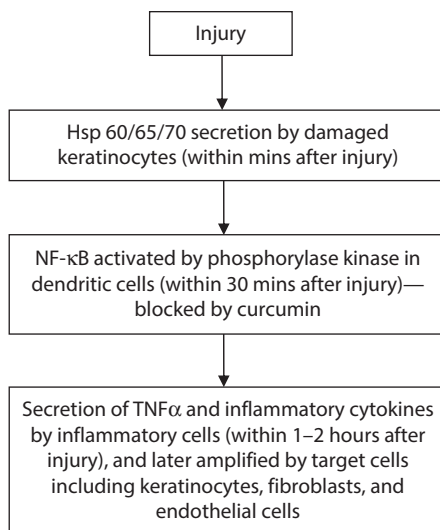

FIGURE 3.1 Sequence of early events in trauma-induced signaling in injured skin. Abbreviations: Hsp (heat shock proteins); NF- κ B (nuclear factor- κ B); TNF α (tumor necrosis factor- α).

trauma, such as tape-stripping in the skin,⁸ burns,⁶ and other injuries.⁷ In a rat model of traumatic injury, NF- κ B activation was observed as early as 30 minutes following induction of injury.^{9,10} The expression of inflammatory cytokines, including tumor necrosis factor- α (TNF α), interleukin -1 β (IL-1 β), and the adhesion molecule intercellular adhesion molecule-1 (ICAM-1), was abrogated with inhibition of NF- κ B by pyrrolidine dithiocarbamate (PDTC).¹¹ This indicates that in injured tissues, cytokine and adhesion molecules are secreted downstream of NF- κ B signaling.¹¹ In our laboratory, we have observed increased activity of PhK in skin biopsies within 5 minutes after tape-stripping (Heng, unpublished data). In the tape-stripped epidermis, activated dendritic cells were also observed within 5 minutes following injury.⁸ In addition, in a rat model of an artery injury, we detected heat-shock protein 65 (hsp65) expression within minutes after arterial ligation and reperfusion injury.¹² Heat shock protein-65 is a cognate antigen recognized by a dendritic subset of T lymphocytes expressing the $\gamma\delta$ -T cell receptor. This dendritic subset is capable of secreting large amounts of inflammatory cytokines, including TNF α , and is among the earliest cells to infiltrate injured tissue.¹³

Heat shock proteins (hsp 60/65/70) are expressed by injured cells and serve as an endogenous ligand for Toll-like receptors (TLR2 and TLR4) expressed on dendritic cells, resulting in secretion of cytokines such as TNF α by these and other inflammatory cells.^{14,15} In trauma-induced signaling, NF- κ B expression was detected in macrophages and endothelial cells within 30 minutes following injury.¹⁰ NF- κ B signaling is activated by PhK and inhibited by curcumin. The sequence of early events in injured skin is summarized in Figure 3.1. By blocking NF- κ B signaling through inhibition of PhK, curcumin has the potential of preventing the secretion of cytokines, adhesion molecules, and growth factors, all of which occur downstream of NF- κ B signaling. By using topical curcumin to block PhK/NF- κ B/TNF α pathways, it may be possible to prevent inflammation-mediated tissue damage, and reduce the harmful effects of injury. The molecular and biochemical basis of the beneficial effects of curcumin on injured skin provides a hypothetical conceptual framework for the potential use of topical curcumin as a cosmetic and therapeutic agent for many types of skin problems.

Role of NF- κ B in Injured Skin: Inhibition by Curcumin

Curcumin has also been found to be an indirect but potent inhibitor of NF- κ B activation.¹⁶ Subsequent to injury, gene transcription is induced by the activation of transcription regulators. Perhaps the earliest major transcription regulator activated by injury is NF- κ B.^{9,10} This transcription activator belongs to a family

of related protein dimers that bind to a common sequence on DNA known as the κB site. In the non-activated state, NF- κB exists as a pair of dimers (p50 and p65) located within the cytoplasm. After activation by injury, these dimers translocate to the nucleus,^{7-9,17} where they bind to DNA, and are responsible for activation of multiple genes following cell injury, including those for cell proliferation, cell migration, neovascularization, fibroblastic proliferation, inhibition of apoptosis, dysregulated cell cycling, and tumor transformation. In photodamaged skin, there may be dysregulated proliferation associated with decreased expression of the p53 suppressor gene, which is important for stabilizing DNA during replication.^{18,19} By upregulating p53 expression,²⁰ curcumin has anti-photocarcinogenic properties.^{7,8,16} In inhibiting cell cycle progression,²⁰ curcumin may also prevent skin malignancies in photodamaged skin.

Activation of NF- κB and I $\kappa\text{B}\alpha$ Kinase: Blocked by Curcumin

The activation of NF- κB is triggered by tissue injury. In the skin, this includes trauma, heat, and laser burns, and ionizing and solar radiation. Following injury, activation of NF- κB involves phosphorylation at three serine specific sites (Ser-276, Ser-529, and Ser-536).^{6,21} In addition, before the NF- κB can translocate to the nucleus, the inhibitory molecule, I $\kappa\text{B}\alpha$, needs to be removed by activation of the enzyme, I $\kappa\text{B}\alpha$ kinase. I $\kappa\text{B}\alpha$ kinase (Figure 3.2) consists of three subunits— α and β subunits, and γ subunit (NEMO) that contains a zinc finger, with an ubiquitin-ligase binding site.²² Activation of I κB kinase requires phosphorylation of sites which are both serine specific and tyrosine specific^{6,7}: Ser-171, Ser-181 and Tyr-188, Tyr-199 on the β subunit, as well as phosphorylation of the zinc finger²³ on the γ subunit. In UV light-induced injury, additional sites (Ser-32, Ser-36, Ser-68) are also phosphorylated.²⁴ These multiple sites of phosphorylation required for activation of I $\kappa\text{B}\alpha$ kinase (Figure 3.2) are dependent on PhK activity, and are inhibited by curcumin.⁷ The zinc finger of the γ subunit (NEMO) is selectively required for NF- κB activation by ultraviolet light radiation.²⁴ The removal of the inhibitory I $\kappa\text{B}\alpha$ molecule through activation of its kinase, I $\kappa\text{B}\alpha$ kinase, enables the activated NF- κB dimers to translocate to the nucleus to activate the transcription of multiple genes, including a family of mitogen-activated protein kinases (MAP kinases),²⁵ which are responsible for cell proliferation. Besides activating NF- κB , UV light injury may also induce activation of other transcription activators such as AP-1 (fos and jun), resulting in activation of c-jun N-terminal kinase (JNK), and the p38 MAPK pathway,²⁶ Curcumin has also been shown to inhibit the c-jun/N-terminal kinase (JNK) signaling²⁷ and c-fos/ERK (extracellular signal-regulated kinase) signaling²⁸ in addition to blocking NF- κB activation.²⁹

NF- κB promotes carcinogenesis in skin and other tissues by increasing the cell survival kinase Akt (a serine-threonine kinase),³⁰ and other NF- κB -dependent cell survival genes involving TRAF₁ (TNF α receptor activating factor-1) and TRAF₂ (TNF α receptor activating factor-2), which block apoptosis of photodamaged cells. Activation of NF- κB allows DNA-damaged and potentially malignant cells to

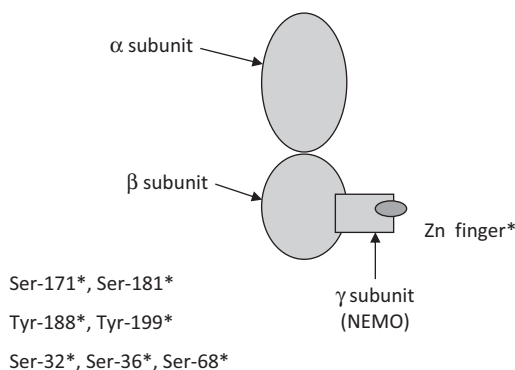

FIGURE 3.2 Details sites of phosphorylation involved in activation of I $\kappa\text{B}\alpha$ kinase. This kinase contains three subunits, α , β , and γ (also called NEMO). The γ subunit (NEMO) contains a zinc finger and ubiquitin ligase site. Activation of I $\kappa\text{B}\alpha$ kinase is blocked by curcumin. *Phosphorylation requirements for activation. (Reproduced with permission from Heng MC. *Int J Dermatol* 2013;62:531–43.)

survive. By blocking Akt³¹ and cell survival proteins, curcumin induces apoptosis^{31–33} of DNA damaged cells that are prone to undergo malignant transformation. This concept is consistent with the current notion that removal of potentially malignant cells by apoptosis is important in both the prevention and treatment of malignancy.^{34,35}

Role of Phosphorylase Kinase in NF- κ B and I κ B α Kinase Activation: Inhibition by Curcumin

Phosphorylase kinase is a unique kinase^{5,6,36,37} in which the spatial arrangements of the specificity determinants can be manipulated to allow PhK to transfer high energy phosphate bonds from ATP to substrates of different specificities, such as serine/threonine and tyrosine. This is achieved by the presence of a hinge joint between the subunits of PhK, which allows changes in the size of the substrate binding site, as well as the ability to change the shape of the substrate binding site by binding either to Mg⁺⁺ or Mn⁺⁺ ions.³⁶ Phosphorylation of multiple serine specific sites (Ser276, Ser529, and Ser536) on the NF- κ B molecule is necessary for the initial partial activation of NF- κ B.²¹ Additionally, phosphorylation of multiple serine specific (Ser171, Ser 181) and tyrosine specific (Tyr188, Tyr198) on the I κ B α kinase (Figure 3.2) molecule is necessary for the removal of the inhibitory molecule (I κ B α)^{22,23} in order that the activated NF- κ B may translocate to the nucleus to bind to DNA for gene transcription. Additionally, the multiple phosphorylations of differing moieties^{5,6} such as serine/threonine in Akt,³⁰ tyrosine in tyrosine kinases, and Thr and Tyr in JNK and p38 MAP kinase, require a dual specificity enzyme such as PhK. Using one enzyme, as with PhK, instead of several enzymes to achieve multiple biochemical functions, has the advantage of synchronization of phosphorylation events that require involvement of multiple sites and different specificities.^{5,6}

Curcumin is a potent specific and non-competitive inhibitor of PhK.^{4,37} Its potential clinical use in a wide range of skin diseases and injuries is probably achieved through its inhibitory effect on PhK.^{4–6,37} By this action, curcumin may affect multiple pathways, including inhibition of I κ B α /NF- κ B^{16,38} and MAP/tyrosine kinase^{39,40}-dependent proliferative pathways, induction of apoptosis^{38,40} by inhibiting the AKT-induced anti-apoptotic pathways,⁴⁰ as well as inhibition of cyclin D1-mediated cell-cycling⁴¹ with salutary effects on proliferative activity and survival of tumor cells. It is believed that curcumin achieves these effects through its ability to inhibit PhK and block the phosphorylation events in these pathways. In addition, since PhK is responsible for generation of tissue ATP, which synergizes with TNF α to produce maturation of dendritic T cells⁴² necessary for the subsequent amplification of the inflammatory response, curcumin minimizes the *magnitude* of the inflammatory response. This may contribute significantly to its efficacy as a therapeutic cosmetic for the prevention of skin injury and the repair of damaged skin.

Figure 3.3 summarizes the signaling pathways blocked by curcumin in injured skin.

By blocking the pathways related to PhK activity, and NF- κ B activation in dendritic cells, curcumin blocks multiple downstream inflammatory pathways which synergize to magnify the deleterious effects following injury. In the absence of curcumin, the injury cascade results in the subsequent secretion of cytokines and growth factors by both immune (T cells, macrophages, and mast cells) and non-immune cells (keratinocytes, fibroblasts, and endothelial cells) that serve to further amplify the immune response and cytokine load. In addition, the synergistic effect of the cytokines, growth factors, and chemokines acting through their respective receptors, trigger activation of multiple pathways and transcription factors that result in gene transcription of multiple genes, with magnification of the deleterious effects on the skin following injury.

The ability of curcumin to block the early stages of the inflammatory cascade triggered by injury may also be the basis for its potential or reported ability to heal burns with minimal scarring,^{5,6} to heal surgical wounds with “perfect regeneration,”⁷ and to repair photodamaged and photoaging skin.^{5,6} By blocking PhK activity, curcumin also blocks ATP generation. This has the effect of preventing the maturation of dendritic cells since ATP has been shown to synergize with TNF α to promote dendritic cell activation and maturation.⁴² By preventing dendritic cell maturation, curcumin may function to curb the amplification of the injury-induced inflammatory response, which is particularly important in the prevention of excessive scarring after burns, and in the healing of skin damaged by solar injury and ionizing radiation.

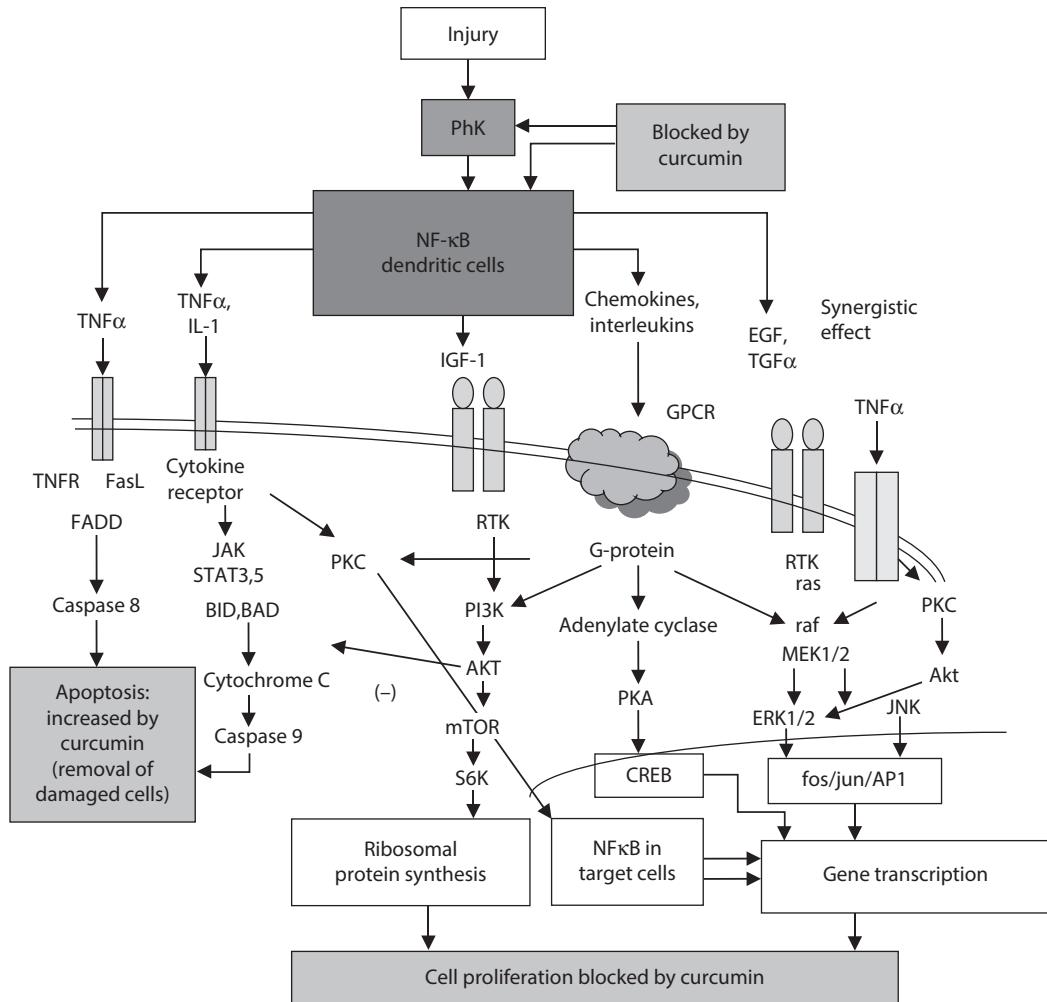

FIGURE 3.3 Summarizes the NF-κB-dependent signaling pathways blocked by curcumin through inhibition of phosphorylase kinase activity. By blocking NK-κB activity in the dendritic cells, curcumin is capable of blocking TNFα-dependent and cytokine-dependent pathways and receptor-mediated tyrosine-kinase gene-dependent gene transcription in target cells. Phosphorylase kinase is necessary for ATP generation, which synergizes with TNFα to cause dendritic cell maturation.

Types of Skin Injury

The ability of topical curcumin to assist in skin repair after injury may be a very important effect that accounts for its widespread and longstanding popularity as a therapeutic cosmetic. The common types of injury include surgical wounds, burns from heat (fires, heating pads, and scalds), laser burns, solar-induced injury from UV radiation, and burns from ionizing radiation. The different types of wounds vary with respect to their propensity to develop scarring, as well as a tendency for malignant transformation. The pathways blocked by curcumin which may assist in skin repair with different types of injury are discussed below.

Burns and Traumatic Wounds

Acute injury such as burns and scalds usually result in blister formation, swelling, and erythema, causing considerable pain to the patient, and resulting in loss of function. Excessive solar exposure causes

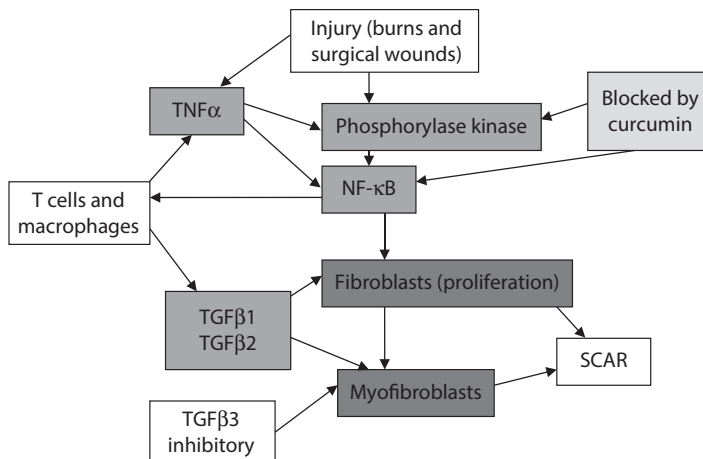

FIGURE 3.4 Signaling pathways in scar tissue formation after injury: targets for anti-scarring therapy by topical curcumin.

acute sunburns, resulting in pain, erythema, and blistering. Sunburns are due to UV light injury mainly in the UVB spectrum (290–320 nm wavelength). Toxic chemicals cause “chemical burns,” damaging cytoplasmic proteins and releasing caspases from the mitochondria, and resulting in cellular necrosis or apoptosis. Laser-induced injury, which depends on the type of laser and wavelengths emitted by the instrument, usually resembles heat injury.

Burns and scalds are caused by heat injury to cellular proteins, resulting in coagulative necrosis of cells, and damage to cellular proteins within the cytoplasm and nucleus. Damage to DNA in the nucleus sets up the well-known DNA damage response (DDR) for repair of damaged DNA. However, the accompanying inhibition of cell proliferation (cell cycle arrest) associated with the DNA damage response impairs the ability of the cells to regenerate new cells, slowing down the repair process. Unlike wounds in embryos that usually heal without scarring, adult wounds almost always result in scarring.⁴³ In contrast to embryonic tissue that do not usually express TGFβ1, the adult inflammatory process is associated with release of growth factors, in particular TGFβ1 (transforming growth factor-β1),⁴³ especially after burns and scalds. This results in hypertrophic scar formation, which is commonly observed with second and third degree burns and scalds, with increasing scarring in deeper wounds.⁷ The formation of hypertrophic scars involves the conversion of fibroblasts to myofibroblasts,⁴⁴ which is induced by secretion of excessive TGFβ1.^{43–46} Myofibroblasts possess contractile properties,⁴⁴ which result in tissue induration characteristic of hypertrophic scarring and keloid formation. Increased TGFβ1 secretion is also noted in hypertrophic scars and keloids.⁴⁷

Injury to the skin results in signals leading to initiation of a cascade of events in the wound healing process.^{7,43} These include inflammation, neovascularization, scarring and epidermal proliferation, often with post-inflammatory hyperpigmentation or hypopigmentation. One of the earliest signaling events in the injury cascade involves the activation of the transcription activator NF-κB in dendritic cells, which are among the earliest inflammatory cells to respond to skin injury. By inhibiting PhK, which is activated within minutes following injury upstream of NF-κB, curcumin blocks NF-κB-induced signaling, with downstream reduction in inflammation and scar tissue formation from the inhibition of TGFβ1 secretion. This minimizes fibroblast proliferation and myofibroblast conversion. The key anti-scarring signaling pathways and targets blocked by curcumin are summarized in Figure 3.4. Topical curcumin has also been shown to heal burns with minimal scarring,^{5,6} and to achieve similar results in surgical wounds.⁷

Curcumin as an Agent for Rapid Healing of Burns, and UV Light Injury and Photodamaged Skin

The wavelengths in sunlight that produce sunburns are usually attributed to those in the UV range, i.e., UVB (290–320 nm wavelength) and UVA (320–400 nm wavelength). Although UVB wavelengths are

more prone to cause sunburn, current evidence suggests that UVA radiation, which makes up 95% of the solar UV light reaching the Earth, may be the more damaging of the two^{48,49} in regard to photocarcinogenesis (basal cell carcinomas and melanomas) and photoaging (pigmentary changes, wrinkling, and solar elastoses). Additionally, other wavelengths, such as infrared rays that produce heat, may also contribute to the injury observed in acute sunburns and chronic dermal injury.

Cyclobutane Pyrimidine Dimers and DNA Damage

Production of cellular point mutations and mutagenic cyclobutane pyrimidine dimers (CPD) has been shown with both UVB and UVA exposure. However, the CPDs produced by UVB tend to be easily removed and cause limited injury to the DNA. On the other hand, CPDs produced by UVA tend to be predominantly thymine–thymine pyrimidine dimers, which are located at the apex of the helical DNA strands, are difficult to remove, and tend to produce damage to large segments of the DNA.^{48,49} The damage induced by the large double-stranded DNA breaks are difficult to repair,^{48,49} and frequently result in errors of replication that cause normal cells to transform into their malignant counterparts.^{6,48,49} In addition, it has been observed that the “bystander effect,”⁵⁰ in which tissue damage occurs outside the areas exposed to UV light, has only been observed with UVA radiation but not with UVB,⁵⁰ accounting for many skin cancers and melanomas that develop in areas not exposed to solar radiation.

Signaling Pathways Induced by Acute and Chronic Solar Injury: Inhibition by Curcumin

Sunburn resembles other skin injuries in producing an inflammatory cascade that invokes the wound repair mechanism. The repair processes, resulting in the formation of new blood vessels and fibroblastic proliferation, frequently lead to dermal scarring. In addition, the skin damage results in epidermal and melanocytic proliferation, which are noted clinically as keratotic and pigmentary lesions. Repeated solar skin damage may lead to formation of premalignant solar lentigenes and dysplastic nevi. With chronic solar damage, DNA injury may result in photocarcinogenesis, with dysregulated cell cycling and malignant transformation.⁵ The above processes may lead to development of squamous cell and basal cell carcinomas, as well as malignant melanomas that can manifest clinically as lentigo maligna, superficial spreading melanomas, and nodular melanomas. The solar-induced injury pathways are mediated by NF-κB²¹-dependent signaling, and may potentially be inhibited by curcumin,^{5,6,16} as shown in Figure 3.5.

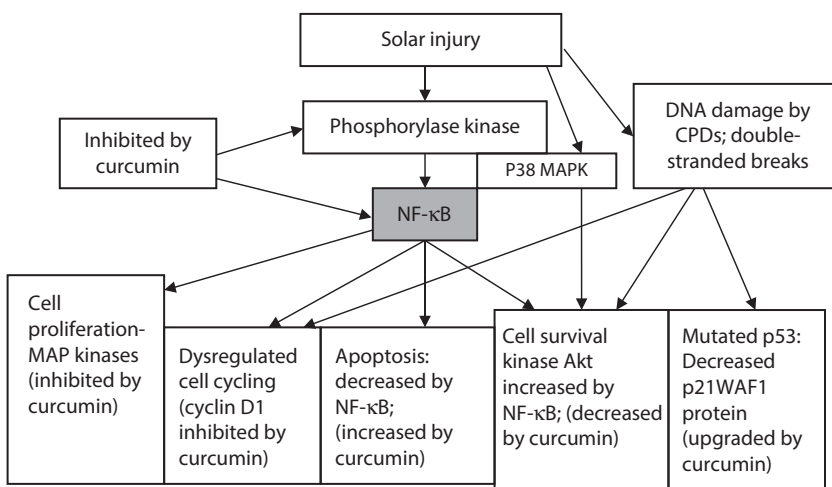

FIGURE 3.5 Signaling targets in acute and chronic solar injury inhibited by curcumin.

Besides the rapid heat shock protein-induced NF- κ B activation mediated by Toll receptors,^{14,15} and MAP kinase signaling,²⁵ another rapid-response cell survival pathway initiated by reactive oxygen species in response to UV irradiation in human keratinocytes has been identified, resulting in activation of pathways such as p38 MAP kinases and AKT,^{51–53} with activation of additional transcription activators.^{52,53} In cultured human keratinocytes, phosphorylation of p38 MAP kinase was initiated at 5 minutes, peaked at 30 minutes, and remained elevated up to 2 hours, while the phosphorylation of AKT started at 15 minutes, peaked at 1 hour, and remained elevated beyond 2 hours. It is likely that PhK, which is also activated within 5 minutes after injury, may also play a role in the phosphorylation of both p38 MAP kinase and AKT survival kinase. These alternative pathways synergize with the canonical pathways to amplify the immune response to injury. Using curcumin to block both the canonical and alternative pathways simultaneously has the advantage of synchronized mitigation of the amplified injury-induced inflammatory response. These mechanisms may be responsible for the anti-carcinogenic properties and reparative properties of curcumin reported clinically.^{5–7}

Laser and IPL Injury

While the severity of laser injury is dependent on the wavelength and intensity of the beam, laser damage to tissues appear to be similar to heat-induced injury.^{54–58} Skin injury occurs with more highly powered lasers. Laser beams and even broad spectrum radiation (intense pulsed light or IPL) ranging from the near UV visible spectrum to the infrared spectrum just below the microwave spectrum (400–1400 nm) can produce damage by heat injury. Blistering and post-inflammatory hyperpigmentation has been observed with laser burns in the skin,⁵⁴ with damage consistent with changes from heat-induced injury.^{55–57}

The sequence of inflammatory events following laser or IPL injury appears to be similar to those found with heat, UV light, and ionizing radiation. Within one hour following laser damage, dendritic cells, macrophages, and microglia were observed to migrate towards sites of injury.⁵⁷ In patients with sun-damaged skin who received five monthly treatments, with one group receiving IPL and a second group receiving treatment with 1064 nm Nd:Yag laser, scattered dendritic cells expressing heat shock protein 70 were observed in the papillary and upper reticular dermis with both IPL and Nd:YAG laser treatments, and were associated with the expression of procollagen 1.⁵⁷ These changes were seen in the post-treatment but not in the pre-treatment biopsies.⁵⁷

Increased risk of IPL-induced or laser-induced injury is observed with increasing doses, multiple treatments with short intervening periods, lack of cooling techniques, and the addition of other therapies such as photosensitizers in photodynamic therapy, including ala-aminolevulinic acid (Levulan). We have observed beneficial effects with the use of curcumin gel in injured skin from laser, IPL, and Levulan treatments (Heng MCY: unpublished data).

Clinical Applications

Patient 1 (Figure 3.6) is a 90-year-old man with a basosquamous carcinoma with sclerosing features treated by repeated Moh's micrographic surgery and cryotherapy. Despite these treatments, the tumor progressed to involve the right alar nose down to and including the nostril, nasal tip, and right nasal side-wall. The lesion was excised and a free skin graft was taken from a donor site situated over the mid forehead. Revascularization was enhanced with vicryl sutures between the base of the graft and the deep tissues. These serve like umbilical cords to enhance revascularization⁵⁹ of the free graft from the deep tissues. The graft was stitched in place with 50 and 60 Ethilon placed 1–2 mm apart in order to prevent entry of oxygen, which may cause reperfusion injury, into the tissues. Skin sutures were removed in 2–4 weeks. Post-surgical scarring was prevented by the use of twice daily application of extra-strength topical curcumin in a gel preparation.

Patient 2 (Figure 3.7) is a 92-year-old female with a large basosquamous carcinoma situated over the right nasal side wall and mid nasal ridge. After excision, the defect was closed with a full thickness



FIGURE 3.6 Patient 1 with a basosquamous carcinoma with sclerosing features excised with the underlying cartilage (left panel). The defect was grafted with a free skin graft from the mid-forehead (mid panel). Minimal scarring was observed with the use of extra strength curcumin gel (right panel). (Reproduced with permission from Heng MC. *JCDSA* 2012;2:201–11.)

free skin graft taken from the glabella forehead. Revascularization was enhanced using the “umbilical cord” technique with 40 Vicryl sutures attached from the lower surface of the free graft to the deep tissues. The graft was attached with stitches placed 1–2 mm apart. Following removal of the sutures four weeks later, scarring was minimized with the use of topical curcumin gel (extra-strength) massaged with the fingers twice daily to the healing wound.

Patient 3 (Figure 3.8) is a 75-year-old diabetic female with a squamous cell carcinoma situated over the periungual area of her left great toe. Following excision of the tumor, the defect was closed using a free full-thickness skin graft taken from a donor site situated over her left calf. Revascularization was achieved with the umbilical cord technique, and residual scarring minimized with the use of extra-strength topical curcumin gel.

Patient 4 (Figure 3.9) is a two-year-old boy who sustained severe burns over both hands from falling into a camp fire. He was treated in several emergency rooms with Silvadene cream, but developed worsening of his swelling (Figure 3.9a) and complained of increasing pain. Four days later, he was put on topical curcumin gel with instructions to apply the gel at hourly intervals. He was also put on a short course (10 days) of oral prednisone. He was improved when seen the following day with decreased swelling and pain (Figure 3.9b), and was almost healed two weeks later (Figure 3.9c). When followed

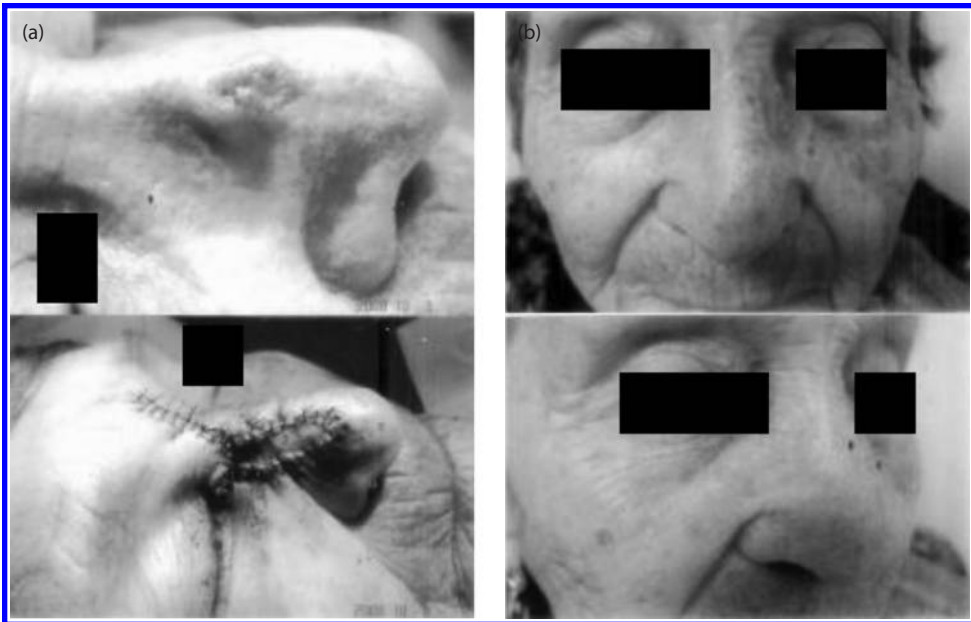

FIGURE 3.7 (a) Patient 2 with a large basosquamous carcinoma situated over the mid nasal ridge and right nasal wall (upper panel). Following excision the defect was closed with a full-thickness free skin graft taken from the glabella forehead. The graft was stitched in place and revascularization enhanced using the umbilical cord technique. (b) Patient 2 following removal of the sutures four weeks later; scarring was minimized with the use of extra-strength curcumin gel. (Reproduced with permission from Heng MC. *JCDSA* 2012;2:201–11.)

up two months after the injury, healing was complete, with no evidence of erythema, scarring, or loss of function (Figure 3.9d).

Patient 5 (Figure 3.10) suffered severe solar burns after falling asleep in the sun (Figure 3.10, upper panel). After applying curcumin gel (every two hours), her solar burns were markedly improved, together with no pain when seen two days later (Figure 3.10, lower panel). At that time, it was noted that blister formation was aborted, and the previous hemorrhagic lesions (upper panel) were much improved (lower panel).

Patient 6 (Figure 3.11). The patient, a 76-year-old man with severely photodamaged skin, presented with actinic poikiloderma with marked skin atrophy and telangiectasia, and multiple actinic keratoses and pigmentary changes (upper panel). He improved with curcumin gel applied twice daily with improvement in both telangiectasia and skin texture over a course of nine months (lower panel), with intermediate changes after three months (middle panel). The unresolved lesion over his mandibular cheek showed an early squamous cell carcinoma on biopsy, and the lesion was eventually excised completely with conventional surgery.

Patient 7 (Figure 3.12). The patient presented with severely photodamaged skin with severe solar elastosis and a large keratotic lesion on the dorsum of the hands. Extra-strength curcumin gel was applied twice daily, and the patient showed improvement of his solar elastosis 15 months later. He also had a hyperkeratotic actinic keratosis which also improved with curcumin gel therapy.

Patient 8 (Figure 3.13). The patient, a 55-year-old female, presented with sun-damaged skin with severe solar elastosis and multiple actinic keratoses over the dorsum of her hands (upper panel). Curcumin gel was prescribed twice daily, and there was improvement in both the actinic keratoses and solar elastoses when seen four months later (lower panel).

Patient 9 (Figure 3.14). The patient, a 75-year-old man, presented with severely photodamaged skin with multiple solar lentigenes and dysplastic nevi over the sun-exposed skin. The dysplastic lesions (upper panel) were treated with curcumin gel twice daily, with improvement in both the texture of the skin and dysplastic lesions when seen four months later (lower panel).



FIGURE 3.8 Patient 3 (diabetic) with a periungual squamous cell carcinoma over her left great toe (upper panel). Following excision of the tumor, the defect was closed with a free skin graft (middle panel), which was taken from the donor site over her left calf. Revascularization was achieved with the umbilical cord technique. Scarring was minimized with extra-strength curcumin gel (lower panel). (Reproduced with permission from Heng MC. *JCDSA* 2012;2:201–11.)

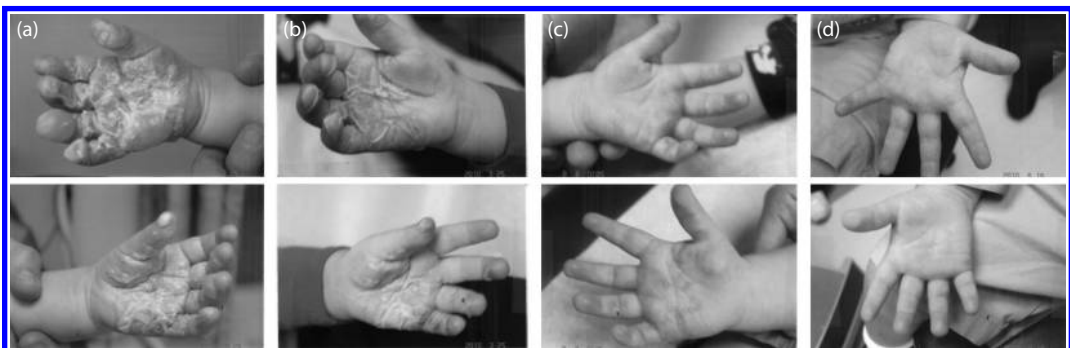

FIGURE 3.9 (a) Patient 4, seen four days later after falling into a camp fire. Observe severe blistering over the palms of both hands, suggestive of at least a second degree burn. (b) Patient 4 was seen the following day showing improvement in edema and pain after using curcumin gel at hourly intervals (total of six applications). (c) Patient 4 seen two weeks after curcumin gel (applied frequently). Note extensive re-epithelialization, with resolution of pain. (d) Patient 4 with complete healing with curcumin gel two months following the injury. There was no erythema, scarring, or loss of function.



FIGURE 3.10 Patient 5 who sustained solar burns after falling asleep in the sun. Note the hemorrhagic erythema and early blister formation (left panel). After frequent applications of curcumin gel, there was resolution of the hemorrhagic erythema and pain when seen two days later (right panel). Blister formation was aborted, and scaling was mild to minimal.

Summary

Phosphorylase kinase is a unique enzyme in which the spatial arrangements of the specificity determinants can be manipulated so that the enzyme can transfer high energy phosphate bonds to sites of differing specificities, such as serine, threonine, and tyrosine. Phosphorylase kinase may be involved in the early response mechanism that is responsible for the initiation and subsequent amplification of inflammation induced by multiple injurious stimuli. By synergistically augmenting ATP tissue supplies, and phosphorylating multiple serine/threonine and tyrosine specific sites, including those molecules required

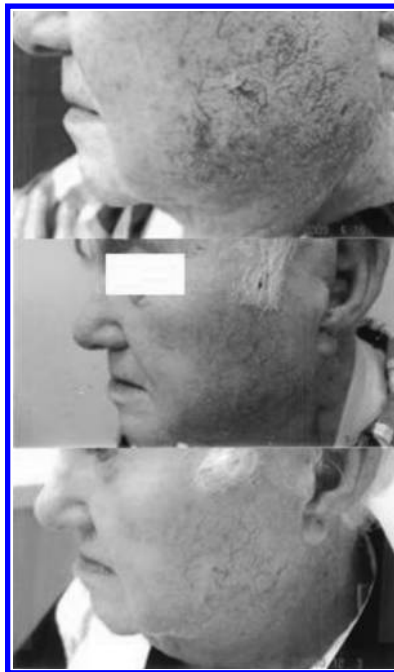

FIGURE 3.11 Patient 6 with severely photodamaged skin before using curcumin gel. Note severely atrophic skin with marked poikilodermatous telangiectasia, with a bowenoid actinic keratosis/early squamous cell carcinoma over his left cheek. Improvement in both skin texture and telangiectasia was seen after three months (middle panel) and nine months (lower panel). The biopsy-proven squamous cell carcinoma was excised by conventional surgery, leaving a residual scar, which was improved with the use of curcumin gel. (Reproduced with permission from Heng MC. *Int J Dermatol* 2013;62:531–43.)

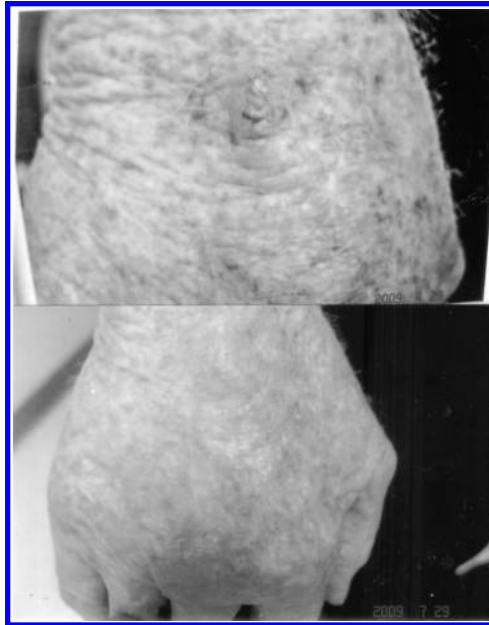

FIGURE 3.12 Patient 7 with the presence (upper panel) of severe solar elastosis on the dorsum of the hand, together with an actinic keratosis. Note improvement of both the solar elastosis and actinic keratosis (lower panel) after 15 months treatment with curcumin gel massaged into the skin twice daily.

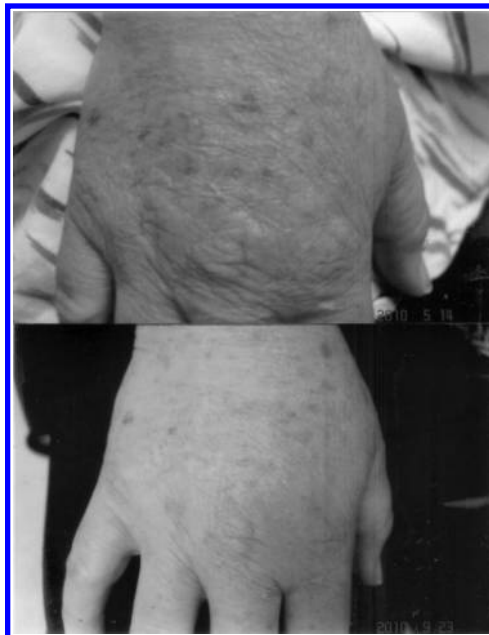

FIGURE 3.13 Patient 8 presented with severely damaged skin particularly over the dorsum of her hands. Note the presence of multiple actinic keratoses and wrinkling and loss of elasticity from solar elastosis (upper panel). There was improvement in both actinic keratoses and skin texture from improvement in her solar elastosis when seen four months later (lower panel).

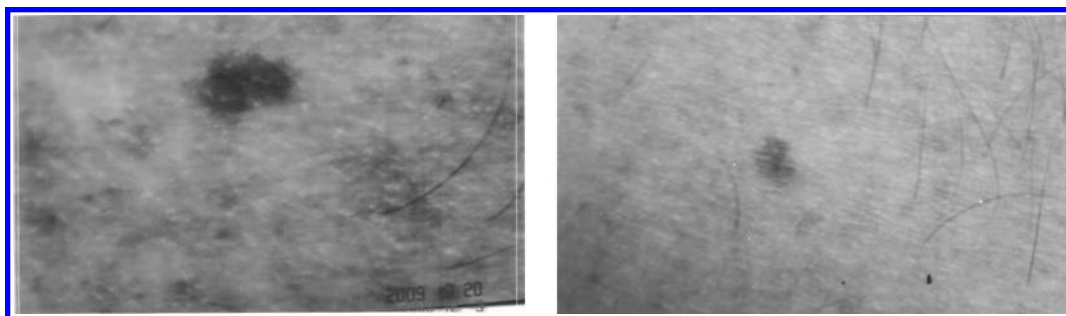

FIGURE 3.14 Patient 9 shows the presence of severely photodamaged skin with multiple pigmentary changes (solar lentigenes/pigmented actinic keratosis and a large dysplastic nevus situated over the anterior chest (left panel). Note improvement in the pigmented lesions including the dysplastic nevus, as well as skin texture, when seen four months later with curcumin gel applied twice daily (right panel).

for transcription activation, phosphorylase kinase can affect multiple pathways involved in cytokine/growth factor/chemokine-mediated inflammation involving cell proliferation, cell cycling, cell migration, inhibition of apoptosis, dysregulated cycling, and tumor transformation, with their attendant deleterious effects on injured tissues. By blocking these pathways with curcumin, a phosphorylase kinase inhibitor, it may be possible to mitigate these injury-triggered deleterious effects. Because of the poor bioavailability of oral curcumin, a topical curcumin preparation has been used to demonstrate the salutary effects of phosphorylase kinase inhibition in injured skin, in particular in the optimal healing of burns, surgical wounds, and photodamaged skin.

REFERENCES

1. Sharma RA, Steward WP, Gescher AJ. Pharmacokinetics and pharmacodynamics of curcumin. *Adv Exp Med Biol* 2007;595:453–70.
2. Jurenka JS. Anti-inflammatory properties of curcumin, a major constituent of *Curcuma longa*: A review of preclinical and clinical research. *Altern Med Rev* 2009;14:141–53.
3. Arnand P, Kunnumakkara AB, Newman RA et al. Bioavailability of curcumin: Problems and promises. *Mol Pharm* 2007;4(6):807–18.
4. Reddy S, Aggarwal BB. Curcumin is a non-competitive and selective inhibitor of phosphorylase kinase. *FEBS Lett* 1994;341:19–22.
5. Heng MC. Curcumin-targeted signaling pathways: Basis for anti-photoaging and anti-carcinogenic therapy. *Int J Dermatol* 2010;49:608–22.
6. Heng MC. Signaling pathways target by curcumin in acute and chronic injury: Burns and photodamaged skin. *Int J Dermatol* 2013;62:531–43.
7. Heng MC. Wound healing in adult skin: Aiming for perfect regeneration. *Int J Dermatol* 2011;50:1058–66.
8. Heng MC, Kloss SG, Kuehn CS et al. The sequence of events in psoriatic plaque formation after tape-stripping. *Br J Dermatol* 1985;112:517–32.
9. Feezor RJ, Paddock HN, Baker HV et al. Temporal patterns of gene expression of gene expression in murine cutaneous burn wound healing. *Physiol Genomics* 2004;16:341–8.
10. Bethea JR, Castro M, Keane RW et al. Traumatic spinal cord injury induces nuclear factor- κ B activation. *J Neurosci* 1998;18:3251–60.
11. You WC, Wang CX, Pan YX et al. Activation of nuclear factor- κ B in the brain after experimental subarachnoid hemorrhage and its potential role in delayed brain injury. *PLoS One* 2013;8(3):e60290.
12. Heng MK, Heng MC. Heat shock protein 65 and activated gamma-delta T cells in injured arteries. *Lancet* 1994;344:921–3.
13. Heng MK, Heng MC, Rollandelli R et al. Early infiltration of arterial intima by activated dendritic gamma-delta T-cells in ligated human arteries: An ultrastructural and immunocytochemical study. *Int College Angiol* 1997;6:167–72.

14. Ohashi K, Burkhardt V, Flohe S et al. Cutting edge: Heat shock protein 60 is a putative endogenous ligand of the toll-like receptor-4 complex. *J Immunol* 2000;164:558–61.
15. Vabulas RM, Ahmad-Nejad P, da Costa C et al. Endocytosed HSP60s use toll-like receptor-2(TLR2) and TLR4 to activate the toll/interleukin 1 receptor signaling pathways in innate immune cells. *J Biol Chem* 2001;276:31332–9.
16. Singh S, Aggarwal BB. Activation of transcription factor NF-kappa B is suppressed by curcumin (diferuloylmethane). *J Biol Chem* 1995;270:24995–5000.
17. Bharti AC, Aggarwal BB. Nuclear factor-kB and cancer: Its role in prevention and therapy. *Biochem Pharmacol* 2002;64:883–8.
18. Brash DE, Ziegler A, Jonsson AS et al. Sunlight and sunburn in human cancer: p53, apoptosis, and tumor promotion. *J Invest Dermatol* 1996;1:136–42.
19. El Deiry WS, Tokina T, Vekulescu VE et al. WAF1, a potential mediator of p53 tumor suppression. *Cell* 1993;75:817–25.
20. Park MJ, Kim EH, Park IC et al. Curcumin inhibits cell cycle progression of immortalized human umbilical vein endothelial (ECV304) cells by up-regulating cyclin-dependent kinase inhibitor, p21WAF1/CIP1, p27KIP1 and p53. *Int J Oncol* 2002;21:379–83.
21. Takada Y, Singh S, Aggarwal BB. Identification of p65 peptide that selectively inhibits NF-kappa B activation induced by various inflammatory stimuli and its role in down-regulation of NF-kappaB-mediated gene expression and up-regulation of apoptosis. *J Biol Chem* 2004;279:15096–104.
22. Karin M, Ben-Neriah Y. Phosphorylation meets ubiquitination: The control of NF-[kappa]B activity. *Annu Rev Immunol* 2000;18:621–63.
23. Palkowitsch L, Leidner J, Ghosh S et al. Phosphorylation of serine 68 in the IkappaB Kinase (IKK)-binding domain of NEMO interferes with the structure of the IKK complex and tumor necrosis factor-alpha-induced NF-kappaB activity. *J Biol Chem* 2008;283:76–86.
24. Huang TT, Feinberg SL, Suryanarayanan S. et al. The zinc finger domain of NEMO is selectively required for NF-kappa B activation by UV radiation and topoisomerase inhibitors. *Moll Cell Biol* 2002;22:5813–25.
25. Bode AM, Dong Z. Mitogen-activated protein kinase activation in UV-induced signal transduction. *Sci STKE* 2003;2003(167)RE2.
26. Tanos T, Marinissen MJ, Leskow FC et al. Phosphorylation of c-Fos by members of the p38 MAPK family. Role in the AP-1 response to UV light. *J Biol Chem* 2005;280:18842–52.
27. Chen YR, Tan TH. Inhibition of the c-jun N-terminal kinase (JNK) signaling pathway by curcumin. *Oncogene* 1998;17:173–8.
28. Cho JW, Park K, Kweon GR et al. Curcumin inhibits the expression of COX-2 in UVB-irradiated human keratinocytes (HaCaT) by inhibiting activation of AP-1: p38 MAP kinase and JNK as potential upstream targets. *Exp Mol Med* 2005;37:186–92.
29. Chen A, Zheng S. Curcumin inhibits connective tissue growth factor gene expression in activated hepatic stellate cells *in vitro* by blocking NF-kappaB and ERK signaling. *Br J Pharmacol* 2008;153:557–67.
30. Romashkova JA, Makarov SS. NF-kappaB is a target of AKT in anti-apoptotic PDGF signaling. *Nature* 1999;40:86–90.
31. Shinojima N, Yokoyama T, Kondo Y et al. Roles of Akt/mTOR/p70S6K and ERK signaling pathways in curcumin-induced autophagy. *Autophagy* 2007;3:635–7.
32. Choudhuri T, Pal S, Das T et al. Curcumin selectively induces apoptosis in deregulated cyclin D1-expressed cells at the G2 phase of the cell cycle in a p53 dependent manner. *J Biol Chem* 2005;280:11680–5.
33. Anto RJ, Mukhopadhyay A, Denning K et al. Curcumin (diferuloylmethane) induces apoptosis through activation of caspase-8, BID cleavage and cytochrome c release: Its suppression by ectopic expression of Bcl-2 and Bcl-xl. *Carcinogenesis* 2002;23:143–50.
34. Thompson HJ, Strange R, Schedin PJ. Apoptosis in the genesis and prevention of cancer. *Cancer Epidemiol Biomarkers Prev* 1992;1:597–602.
35. Watson J. Oxidants, antioxidants and the current incurability of metastatic cancers. *Open Biol* Jan 2013;3(1):120144.
36. Yuan CJ, Huang CYE, Graves DJ. Phosphorylase kinase: A metal ion dual specificity kinase. *J Biol Chem* 1991;268:17683–6.

37. Heng MCY, Song MK, Heng MK. Drug-induced suppression of phosphorylase kinase activity correlates with resolution of psoriasis as assessed by clinical, histological and immunohistochemical parameters. *Br J Dermatol* 2000;143:937–49.
38. Bharti AC, Donato N, Singh S et al. Curcumin (diferuloylmethane) down-regulates the constitutive regulation of nuclear factor-kappa B and IkappaBalpha kinase in human multiple myeloma cells, leading to suppression of proliferation and induction of apoptosis. *Blood* 2003;101:1053–62.
39. Hong RL, Spohn WH, Hung MC. Curcumin inhibits tyrosine kinase activity of p185neu and also depletes p185neu. *Clin Cancer Res* 1999;5:1884–91.
40. Aggarwal S, Ichikawa H, Takada Y et al. Curcumin (diferuloylmethane) downregulates expression of cell proliferation and antiapoptotic and metastatic gene products through suppression of IkappaBalpha kinase and Akt activation. *Mol Pharmacol* 2006;69:195–206.
41. Mukhopadhyay A, Banerjee S, Stafford LJ et al. Curcumin-induced suppression of cell proliferation correlates with down-regulation of cyclin D1-expression and CDK4-mediated retinoblastoma protein phosphorylation. *Oncogene* 2002;21:8852–61.
42. Schnurr M, Then F, Galambos P et al. Extracellular ATP and TNF-alpha synergize in the activation and maturation of human dendritic cells. *J Immunol* 2000;165:4704–9.
43. Martin P. Wound healing—Aiming for perfect skin regeneration. *Science* 1997;276:75–81.
44. Grinnell F. Fibroblasts, myofibroblasts and wound contraction. *J Cell Biol* 1994;124:401–4.
45. Frank S, Madlener M, Werner S. Transforming growth factor beta1, beta2 and beta3 and their receptors are differentially regulated during normal and impaired wound healing. *J Biol Chem* 1996;271:10188–91.
46. Desmoliere A, Geinoz A, Gabbiani F et al. Transforming growth factor-beta 1 induces alpha smooth muscle actin expression in granulation tissue myofibroblasts and in quiescent and growing cultured fibroblasts. *J Cell Biol* 1993;122:103–11.
47. Lee TY, Chin GS, Kim WJ et al. Expression of transforming growth factor beta 1, 2, and 3 proteins in keloids. *Ann Plast Surg* 1999;43:179–84.
48. Rochette PJ, Therrien JP, Drouin R et al. UVA-induced cyclobutane pyrimidine dimers form predominantly at thymine–thymine dipyrimidines and correlate with the mutation spectrum in rodent cells. *Nucleic Acid Res* 2003;31:2786–94.
49. Douki T, Reynaud-Angelin A, Cadet J et al. Bipymidine photoproducts rather than oxidative lesions are the main type of DNA damage involved in the genotoxic effect of solar UVA radiation. *Biochemistry* 2003;42:9221–6.
50. Whiteside JR, McMillan TJ. A bystander effect is induced in human cells treated with UVA radiation but not UVB radiation. *Radiat Res* 2009;171:204–11.
51. Zhang QS, Maddock DA, Chen JP et al. Cytokine-induced p38 activation feedback regulates the prolonged activation of AKT cell survival pathway initiated by reactive oxygen species in response to UV irradiation in human keratinocytes. *Int J Oncol* 2001;19:1057–61.
52. Grether-Beck S, Oliazola-Horn S, Schmitt H et al. Activation of transcription factor AP-2 mediates ultraviolet A radiation and singlet oxygen induced expression of the human intercellular adhesion molecule-1 gene. *Proc Natl Acad Sci USA* 1996;93:14586–91.
53. Minden A, Lin A, McMahon M et al. Differential activation of ERK and JNK mitogen-activated protein kinases by raf-1 and MEKK. *Science* 1994;266:1719–23.
54. Li C, Protsenko DE, Zermek A et al. Analysis of Nd:YAG laser-mediated thermal damage in rabbit basal septal cartilage. *Lasers Surg Med* 2007;39:451–7.
55. Chuang LH, Lai CC, Yang KJ et al. A traumatic macular hole secondary to a high-energy Nd:YAG laser. *Ophthalm Surg Lasers* 2001;32:73.
56. Chan HH, Lam LK, Wong DS et al. Use of 1,320 nm Nd:YAG laser for wrinkle reduction and the treatment of atrophic acne scarring in Asians. *Lasers Surg Med* 2004;34:98–103.
57. Eter N, Engel DR, Meyer L et al. *In vivo* visualization of dendritic cells, macrophages and microglial cells responding to laser-induced damage in the fundus of the eye. *Invest Ophthalmol Vis Sci* 2008;49:3649–58.
58. Prieto VG, Diwan AH, Shea CR et al. Effects of intense pulse light and the 1.064 nm Nd:YAG laser on sun-damaged human skin: Histologic and immunohistochemical analysis. *Dermatol Surg* 2005;5:522–25.
59. Heng MCY. Utilizing free skin grafts in the repair of surgical wounds. *JCDSA* 2012;2:201–11.

4

The Cosmetic and Therapeutic Uses for Epicatechin-3-Gallate (EGCG)

Michael S. Leo, Howard I. Maibach, and Raja K. Sivamani

Overview

Green tea (*Camellia sinensis*) is a popular beverage with many purported health benefits including anti-inflammatory, chemopreventative, antioxidant, sunscreen effects, and more. The active ingredients modulating those benefits in green tea are polyphenols called catechins: epicatechin-3-gallate, epigallocatechin, and epicatechin are three major catechins. Epicatechin-3-gallate, EGCG (Figure 4.1) is most abundant, accounting from 50%–80% of the catechins in a cup of green tea.¹ EGCG has been investigated for cosmetic and medicinal uses; Table 4.1 lists several current products containing green tea extract.

Uses of EGCG in Cosmetics

Anti-Aging Uses

EGCG may have uses as an anti-aging or age-delaying agent. Dermal fibroblasts generate and maintain the collagen in the dermis and are important in wound healing. *In vitro* experiments using serially passaged human dermal fibroblasts in the presence and absence of 100 μ M EGCG significantly prevent senescence of dermal fibroblasts.² This effect appears to occur through p53 acetylation, although the importance for the role of p53 acetylation has been debated.³ This phenomenon also causes a change in cell morphology. However, reaching a 100 μ M concentration of EGCG will be difficult to achieve through diet alone. A typical tea bag can contain anywhere from 1.5–3.3 g of green tea depending on the manufacturer. Consuming 3 g of tea dissolved in 500 mL of water a day leads to a plateau of 300 ng/mL of EGCG in the blood plasma of humans.⁴

Hair Growth

Both *in vitro* and *in vivo* experiments were conducted on dermal papilla cells, which nourish and serve a function in hair follicle growth. The *in vivo* experiments involved applying up to 5 μ M of EGCG in ethanol on the human occipital scalp for four consecutive days in two areas before tissue samples containing hair follicles were excised. Results showed a threefold increase in the expression of proteins involved in the increased proliferation of normal human epidermal keratinocytes.⁵ The *in vitro* experiments showed a dose-dependent increase in dermal papilla cell proliferation. *Ex vivo* experiments utilizing human hair follicle organ cultures treated for 10 days showed a 180% increase in hair follicle elongation.⁵ The biochemistry behind the actions of EGCG on hair growth have yet to be determined as well as its actions on different hair follicle cell types.

Sunscreen

Exposure to ultraviolet (UV) irradiation can lead to various skin cancers by mutating the DNA in epidermal cells, photoaging by degradation of collagen, immune suppression, and sunburns.⁶ UV radiation

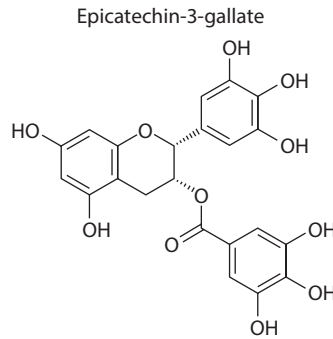

FIGURE 4.1 Chemical structure of epicatechin-3-gallate (EGCG).

causes the release of reactive oxygen species (ROS) that damage DNA and lead to carcinogenesis.⁷ Certain polyphenols possess an antioxidant capacity to neutralize these free radicals.

Both UVA and UVB contribute to photoaging. The breakdown of collagen from UV exposure creates alterations in the extracellular matrix leading to wrinkling of skin. These alterations are mediated by matrix metalloproteinases, MMP, that are increasingly secreted by dermal fibroblasts in the presence of ROS.^{8,9}

Numerous studies have been conducted on the effectiveness of EGCG as a protective agent against UVA and UVB induced skin damage. Kim et al. performed an animal study on guinea pigs to study the preventative effects of EGCG against the UVB induced lipid peroxidation and erythema response. Hairless mice were used to determine the preventative effects of EGCG against UVA induced dermal collagenase activity. Both guinea pigs and mice were treated with a topical formulation consisting of the vehicle, 1% EGCG and 1% vitamin E before UV exposure. Results showed a 2.9-fold reduction in lipid peroxidation in the EGCG protected guinea pigs and a 1.6-fold difference between the erythema relative index of the control to the EGCG group.¹⁰ There were also significant decreases in collagenase activity and collagenase mRNA levels between the control and EGCG groups. EGCG and vitamin E appeared to perform similarly. Guinea pig skin protected by the EGCG formulation appeared to be less loose and rough compared to the control group.¹⁰ *In vitro* experiments support the results that EGCG inhibits the degradation of collagen and induction of collagenase caused by UVB exposure in dermal fibroblasts.¹¹

TABLE 4.1

Commercial Products Containing Green Tea Extracts

Brands	Products
<i>Ti-Silc</i>	<i>SPF-60 +</i>
Olay	Regenerist Perfecting Cream
Derma e	Retinol and Green Tea Advanced Renewal Crème Alpha Lipoderm Alpha Lipoic/Green Tea Advanced Repair Complex
Replenix	Original Serum and Cream Fortified Cleanser Serum and Cream CF CF Purifying Antioxidant Foaming Cleanser CF Anti-Photoaging Complex SPF 45 Exfoliation Scrub

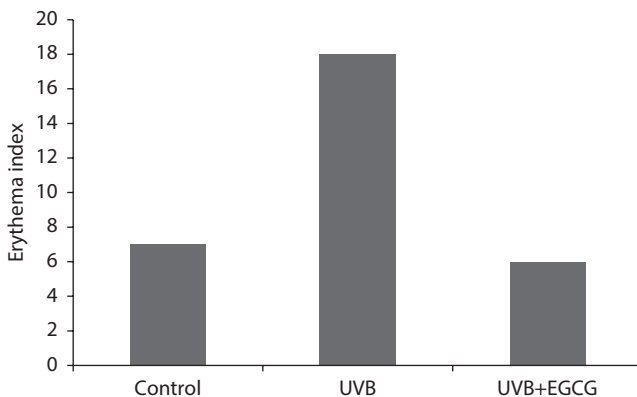

FIGURE 4.2 Topical application of EGCG reduces erythema to the applied buttocks site exposed to UVB *in vivo* human data. The control shin site was not exposed to UVB irradiation. 4 MED UVB dose was delivered to the sites and a chromometer was used to measure the intensity of the redness of the site. (Katiyar SK et al: Polyphenolic antioxidant (–)-epigallocatechin-3-gallate from green tea reduces UVB-induced inflammatory responses and infiltration of leukocytes in human skin. *Photochem Photobiol.* 1999. 69(2). 148–53. Copyright Wiley-VCH Verlag GmbH & Co. KGaA. Reproduced with permission.)

Studies focused on the protective effects of topical EGCG against UVA in albino rats revealed that applying the EGCG formulation 30 minutes before UVA exposure to the selected areas significantly reduced the number of sunburn cells in the epidermis of the rats. However, applying the formulation 30 minutes after exposure provided no benefits.¹² Preventative experiments have been done on human subjects who were irradiated with four times the minimal erythema dosage (MED) on topically applied EGCG protected skin (Figure 4.2). Results showed a decrease in erythema and UVB induced infiltration of leukocytes, which are believed to be a major source of ROS.¹³

Oral formulations of EGCG have also been shown to be effective. Jeon et al. supplemented the diets of hairless rats with 1500 ppm of EGCG for eight weeks while subjecting the rats to UV radiation three times a week. EGCG supplemented mice had a mean MED value of 145 compared to the control group’s 99 (mJ/cm²). Furthermore, the EGCG mice had decreased trans epidermal water loss, TEWL, thereby suggesting better epidermal barrier functions.¹⁴ *In vivo* experiments support these results. Peripheral blood cells were drawn from adult human volunteers before and after drinking 540 mL of green tea. The cells were then exposed to UVA for 12 minutes. There was less DNA damage in eight of ten subjects who ingested green tea than those who had not.¹⁵ Altered DNA methylation silencing is a signal of cancer and Mittal et al. used monoclonal antibodies against 5-methyl cytosine and DNA methyltransferase in the long-term UV-irradiated skin in mice. Treatment with EGCG in a hydrophilic cream reduced global DNA hypomethylation, thereby reducing the incidence of skin carcinomas (Table 4.2).¹⁶ However, in another study oral doses of EGCG from 400 or 800 mg found that EGCG did not protect

TABLE 4.2

Preventative Effect of Topical EGCG on Reducing the Global Hypomethylation *in vivo* Mice Data

Treatment Groups	Maintenance	<i>De Novo</i>
	Methylation (cpm/g Protein)	Methylation (cpm/g Protein)
Normal	79.1 ± 7	62.8 ± 6
UVB alone	46.5 ± 4	78.8 ± 7
EGCG + UVB	65.2 ± 6	54.8 ± 5

Source: Reproduced with permission of Neoplasia Press from Mittal A et al. *Neoplasia* 2003;5(6):555–65. Copyright 2003.

against UV induced erythema.¹⁷ This could suggest that topical formulations of EGCG may be better suited to reduce erythema. A study comparing oral and topical formulations of green tea extracts in 40 women with moderate photoaging found that there was no reduction in photoaging.¹⁸ This suggests that EGCG may perform better as a preventative product rather than repair-damaged tissue.

Applications for EGCG in Skin Diseases

Keloids

Keloids are hyperproliferative fibrotic tissue deposition that occurs during skin healing. The majority of the material deposited is type III collagen that is later replaced by type I collagen. With the use of a keloid organ culture model, Syed et al. tested 100 µg/mL EGCG *in vitro* on keloid organ culture. EGCG decreased keloid volume by 40% on week 4 and increased apoptosis of keloid associated cells by the same amount. Collagen I and III were decreased at both the protein and mRNA levels, keloid mast cells were decreased by 98%, and EGCG induced epidermal shrinkage.¹⁹ EGCG also appears to inhibit keloid fibroblast proliferation and collagen production via inhibition of the STAT3 and the PI3K/AKT signaling pathways.^{20,21}

Wound Healing

EGCG has been demonstrated to be beneficial in the area of wound healing, although the mechanism is not fully understood. Cell culture studies with human keratinocytes reveal that EGCG enhances keratinocyte differentiation without promoting apoptosis.²² This suggests that EGCG may be useful in wound healing and skin diseases such as psoriasis that involve rapid turnover of undifferentiated keratinocytes. However, another study showed that EGCG alone did not alter human fibroblasts or keratinocyte proliferation. Combination of EGCG with alpha-lipoic acid was superior to EGCG alone in improving the rate of wound closure in mice.²³ Aside from stimulating wound healing, EGCG is also effective against burn wound infections. Using nanoliposomes to increase the half-life and effectiveness of EGCG, the cationic EGCG loaded nanoliposomes were shown to decrease wound infection by *Staphylococcus aureus*. The killing rate of the EGCG reached 100%. The survival rate of the 10 mice treated by the cationic EGCG nanoliposomes was 100%.²⁴ These results suggest that EGCG could be used as a topical formulation to enhance wound healing and decrease infection rates.

Psoriasis

Psoriasis, a disease of increased epidermal proliferation of keratinocytes, leads to a compromised barrier and inflammation due to an abnormal stratum corneum. Caspase 14 is associated with terminal keratinocyte differentiation, barrier formation, and with cornification and nuclear destruction of the keratinocyte cells but its expression is altered in human psoriatic tissue. Hsu et al. used both human epidermal keratinocyte cell cultures and flaky skin mice to determine if the use of a topical EGCG formulation can modulate the expression of the caspase 14 protein. The flaky skin mice bathed in 0.5% EGCG had more than twofold greater expression of the catalytically active form of the caspase 14 than the control mice had. The mice treated with EGCG also showed improved clinical and histological signs compared to that of the control mice.²⁵

Acne Vulgaris

Acne vulgaris is a complex chronic skin disorder that is prevalent in more than 85% of adolescents in the United States.²⁶ Increased sebum production, inflammation, and *Propionibacterium acnes* (*P. acnes*) activity are three major processes that promote acne.²⁷ Seb-1 human sebocytes treated with EGCG were found to have decreased lipid production (Figure 4.3). EGCG mitigated the inflammatory responses induced by exposure to *P. acnes*.²⁸ These anti-inflammatory effects are supported in another study where SZ95 sebocytes were treated with EGCG and found to have decreased levels of inflammatory cytokines.²⁹ EGCG also inhibits growth of cultured *P. acnes* colonies. Furthermore, treatment with EGCG led to increased sebocyte apoptosis as well as decreased cellular growth *in vitro*. Topical application of

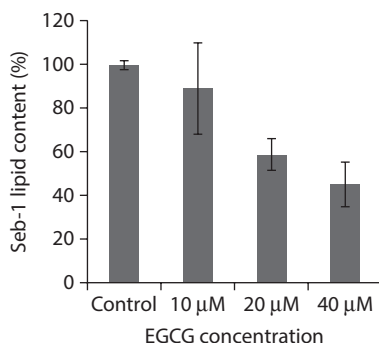

FIGURE 4.3 *In vitro* lipid content of Seb-1 sebocytes after 24 h treatment with EGCG. (Reprinted by permission from Macmillan Publishers Ltd. *J Invest Dermatol*. Yoon JY et al. Epigallocatechin-3-gallate improves acne in humans by modulating intracellular molecular targets and inhibiting *P. acnes*. 2013;133(2):429–40. Copyright 2013.)

EGCG has also been shown to reduce the size of sebaceous glands in rabbit auricles.²⁹ Most significantly, EGCG was able to decrease both inflammatory and non-inflammatory lesion counts on humans receiving topical 1% or 5% EGCG solutions twice a day.²⁸ These results suggest that EGCG could be an effective therapeutic treatment for acne vulgaris.

Atopic Dermatitis

Atopic dermatitis, a chronic autoimmune disease that affects the skin, is characterized by allergic inflammation and local and systemic immune dysfunction leading to an imbalance of Th1 and Th2 cells. Macrophage migration inhibitory factor (MIF) is a crucial immunoregulatory cytokine in the pathogenesis of eczema. MIF is a pro-inflammatory cytokine that prolongs the inflammatory response.³⁰ Considering that EGCG has an anti-inflammatory effect, mice were treated with *Dematophagoides pteronissinus* extract (DPE) to induce eczema like lesions on the ears and treatment with topical EGCG was performed. After three weeks of treatment, ear thickness of the EGCG group was 41.6% less than that of the vehicle treated control and MIF was downregulated to be 1/3 less than the control.³¹ Mast cells contribute to the release of the cytokine thymic stromal lymphopoietin, TSLP, which plays a role in the progression of allergic diseases such as atopic dermatitis. *In vitro* studies have been conducted on human mast cell lines treated with EGCG and a dose dependent drop in TSLP was observed.³² As previously discussed, EGCG has antibacterial properties, which also make it useful in the treatment of eczema. *Staphylococcus aureus* is known to be an exacerbating factor in eczema and produces superantigen staphylococcal enterotoxin B, SEB. Treatment with EGCG on mice injected with SEB decreased the lethal toxicity of the toxin by 100%.³³

Toxicity and Pharmacokinetics

Toxicity studies suggest the safety of using high concentrations of EGCG. Studies determined that a 200 mg/kg oral dose of EGCG induced no toxicity in rats while increasing the dose by ten times was lethal.³⁴ Rats tolerated up to 500 mg/kg/day of EGCG without toxicity. 500 mg/kg/day doses were also fed to dogs without any side effects; however, when the same concentration was fed to fasted dogs, it caused frequent diarrhea, occasional vomiting after feeding, toxic tubular necrosis, liver necrosis, hemolytic anemia, and moderate stomach erosion.³⁴ Toxicity studies were also conducted on topical formulations that was a preparation of 93% EGCG in water at a dose of 2000 mg/kg and covered with a dressing. Minor irritation lasting five days was observed in rats and guinea pigs, but not rabbits. Dermal sensitization studies were conducted on guinea pigs; intradermal injections of 0.09% EGCG was the greatest tolerable dose. A grade 3 erythema was produced but no necrosis. Dermal exposure to EGCG of up to 50% did not evoke any reactions in the animals. Furthermore, EGCG was found to be an eye irritant in rabbits.³⁴ Pharmacokinetic studies regarding the percutaneous absorption of 10% EGCG in a hydrophilic ointment were performed on mouse and human cadaver skin. Intradermal uptake in mice was rapid and

plateaued quickly with an intradermal uptake of up to 19% while the intradermal uptake in human skin was only 0.9% and plateaued by 8 h. Transdermal penetration was only observed in mice. Stability of 10% EGCG in hydrophilic ointment stored for six months was also determined. At 37°C, 10% of the EGCG in the ointment was lost after two days, but the same formulation augmented with 0.1% butylated hydroxytoluene (BHT) had 90% EGCG remaining after 130 days under the same conditions.³⁵

There is no significant increase in the bioavailability of EGCG in human blood plasma from increasing the consumption of EGCG from 219 to 328 mg. A 200 mg dose of EGCG, which equates to approximately 3 g of green tea, maintains near maximum bioavailability and avoids toxicity.⁴ Presumably additional toxicological and continued pharmacological data will extend the voracity of the above observations.

Concluding Remarks

EGCG, a versatile phytochemical extract from green tea, can be used in cosmetic and therapeutic applications and can be administered either topically or orally. Most investigations have focused on cell culture and animal studies; future studies in humans are needed to assess clinical effects.

REFERENCES

1. Khan N et al. Targeting multiple signaling pathways by green tea polyphenol (–)-epigallocatechin-3-gallate. *Cancer Res* 2006;66(5):2500–5.
2. Han DW et al. Preventive effects of epigallocatechin-3-O-gallate against replicative senescence associated with p53 acetylation in human dermal fibroblasts. *Oxid Med Cell Longev* 2012;2012:850684.
3. Prives C, Manley JL. Why is p53 acetylated? *Cell* 2001;107(7):815–8.
4. Yang CS et al. Blood and urine levels of tea catechins after ingestion of different amounts of green tea by human volunteers. *Cancer Epidemiol Biomarkers Prev* 1998;7(4):351–4.
5. Kwon OS et al. Human hair growth enhancement in vitro by green tea epigallocatechin-3-gallate (EGCG). *Phytomedicine* 2007;14(7–8):551–5.
6. Uitto J, Fazio MJ, Olsen DR. Molecular mechanisms of cutaneous aging. Age-associated connective tissue alterations in the dermis. *J Am Acad Dermatol* 1989;21(3 Pt 2):614–22.
7. Cadet J et al. Effects of UV and visible radiation on DNA-final base damage. *Biol Chem* 1997;378(11):1275–86.
8. Brenneisen P et al. Hydrogen peroxide (H₂O₂) increases the steady-state mRNA levels of collagenase/MMP-1 in human dermal fibroblasts. *Free Radic Biol Med* 1997;22(3):515–24.
9. Wlaschek M et al. Singlet oxygen is an early intermediate in cytokine-dependent ultraviolet-A induction of interstitial collagenase in human dermal fibroblasts in vitro. *FEBS Lett* 1997;413(2):239–42.
10. Kim J et al. Protective effects of (–)-epigallocatechin-3-gallate on UVA- and UVB-induced skin damage. *Skin Pharmacol Appl Skin Physiol* 2001;14(1):11–9.
11. Bae JY et al. (–)Epigallocatechin gallate hampers collagen destruction and collagenase activation in ultraviolet-B-irradiated human dermal fibroblasts: Involvement of mitogen-activated protein kinase. *Food Chem Toxicol* 2008;46(4):1298–307.
12. Sevin A et al. Effects of polyphenols on skin damage due to ultraviolet A rays: An experimental study on rats. *J Eur Acad Dermatol Venereol* 2007;21(5):650–6.
13. Katiyar SK et al. Polyphenolic antioxidant (–)-epigallocatechin-3-gallate from green tea reduces UVB-induced inflammatory responses and infiltration of leukocytes in human skin. *Photochem Photobiol* 1999;69(2):148–53.
14. Jeon HY et al. Effects of oral epigallocatechin gallate supplementation on the minimal erythema dose and UV-induced skin damage. *Skin Pharmacol Physiol* 2009;22(3):137–41.
15. Morley N et al. The green tea polyphenol (–)-epigallocatechin gallate and green tea can protect human cellular DNA from ultraviolet and visible radiation-induced damage. *Photodermatol Photoimmunol Photomed* 2005;21(1):15–22.
16. Mittal A et al. Exceptionally high protection of photocarcinogenesis by topical application of (–)-epigallocatechin-3-gallate in hydrophilic cream in SKH-1 hairless mouse model: Relationship to inhibition of UVB-induced global DNA hypomethylation. *Neoplasia* 2003;5(6):555–65.

17. Chow HH et al. Pharmacokinetics and safety of green tea polyphenols after multiple-dose administration of epigallocatechin gallate and polyphenon E in healthy individuals. *Clin Cancer Res* 2003;9(9):3312–9.
18. Chiu AE et al. Double-blinded, placebo-controlled trial of green tea extracts in the clinical and histologic appearance of photoaging skin. *Dermatol Surg* 2005;31(7 Pt 2):855–60; discussion 860.
19. Syed F et al. *Ex vivo* evaluation of antifibrotic compounds in skin scarring: EGCG and silencing of PAI-1 independently inhibit growth and induce keloid shrinkage. *Lab Invest* 2013;93(8):946–60.
20. Park G et al. Green tea polyphenol epigallocatechin-3-gallate suppresses collagen production and proliferation in keloid fibroblasts via inhibition of the STAT3-signaling pathway. *J Invest Dermatol* 2008;128(10):2429–41.
21. Zhang Q et al. Green tea extract and (–)-epigallocatechin-3-gallate inhibit mast cell-stimulated type I collagen expression in keloid fibroblasts via blocking PI-3K/AkT signaling pathways. *J Invest Dermatol* 2006;126(12):2607–13.
22. Balasubramanian S et al. Human epidermal keratinocytes undergo (–)-epigallocatechin-3-gallate-dependent differentiation but not apoptosis. *Carcinogenesis* 2005;26(6):1100–8.
23. Leu JG et al. The effects of gold nanoparticles in wound healing with antioxidant epigallocatechin gallate and alpha-lipoic acid. *Nanomedicine* 2012;8(5):767–75.
24. Gharib A, Faezizadeh Z, Godarzee M. Therapeutic efficacy of epigallocatechin gallate-loaded nanoliposomes against burn wound infection by methicillin-resistant *Staphylococcus aureus*. *Skin Pharmacol Physiol* 2013;26(2):68–75.
25. Hsu S et al. Green tea polyphenol induces caspase 14 in epidermal keratinocytes via MAPK pathways and reduces psoriasiform lesions in the flaky skin mouse model. *Exp Dermatol* 2007;16(8):678–84.
26. James WD. Clinical practice. Acne. *N Engl J Med* 2005;352(14):1463–72.
27. Zouboulis CC et al. What is the pathogenesis of acne? *Exp Dermatol* 2005;14(2):143–52.
28. Yoon JY et al. Epigallocatechin-3-gallate improves acne in humans by modulating intracellular molecular targets and inhibiting *P. acnes*. *J Invest Dermatol* 2013;133(2):429–40.
29. Im M et al. Epigallocatechin-3-gallate suppresses IGF-I-induced lipogenesis and cytokine expression in SZ95 sebocytes. *J Invest Dermatol* 2012;132(12):2700–8.
30. Larson DF, Horak K. Macrophage migration inhibitory factor: Controller of systemic inflammation. *Crit Care* 2006;10(2):138.
31. Noh SU et al. Epigallocatechin-3-gallate improves *Dermatophagoides pteronissinus* extract-induced atopic dermatitis-like skin lesions in NC/Nga mice by suppressing macrophage migration inhibitory factor. *Int Immunopharmacol* 2008;8(9):1172–82.
32. Moon PD, Choi IH, Kim HM. Epigallocatechin-3-O-gallate inhibits the production of thymic stromal lymphopoietin by the blockade of caspase-1/NF-kappaB pathway in mast cells. *Amino Acids* 2012;42(6):2513–9.
33. Hisano M et al. Inhibitory effect of catechin against the superantigen staphylococcal enterotoxin B (SEB). *Arch Dermatol Res* 2003;295(5):183–9.
34. Isbrucker RA et al. Safety studies on epigallocatechin gallate (EGCG) preparations. Part 2: Dermal, acute and short-term toxicity studies. *Food Chem Toxicol* 2006;44(5):636–50.
35. Dvorakova K et al. Pharmacokinetics of the green tea derivative, EGCG, by the topical route of administration in mouse and human skin. *Cancer Chemother Pharmacol* 1999;43(4):331–5.

5

Ellagic Acid

William Tuong and Raja K. Sivamani

Overview

Ellagic acid is a polyphenol compound (Figure 5.1) found in several fruits and nuts, such as raspberries, grapes, strawberries, pomegranates, and walnuts.^{1,2} Several studies have described its antiproliferative and apoptotic effects on certain cancer cell lines.^{3–6} Similar to other polyphenolic phytochemicals, ellagic acid also demonstrates antioxidant effects in several *in vitro* and *in vivo* models.^{7,8} Results from studies investigating the dermatological applications of ellagic acid are promising as well. Specifically, ellagic acid may be effective in improving signs of UV-induced skin aging⁹ and treating hyperpigmentation.^{10–14}

UV-Induced Skin Aging

The mechanism by which ellagic acid may protect UV-induced skin damage is multifactorial. Available evidence suggests that ellagic acid reduces UV-induced production of matrix metalloproteinases that lead to collagen degradation.⁹ Moreover, ellagic acid upregulates nuclear factor erythroid 2-related factor 2 (Nrf2), a transcription factor that controls the expression of several genes encoding antioxidative proteins and cytoprotective mechanisms.¹⁵

Evidence regarding the effectiveness of ellagic acid in preventing photodamage is limited (Table 5.1).⁹ A recent study showed that SKH-1 hairless mice topically treated with ellagic acid (10 $\mu\text{mol/L}$) had less skin wrinkling compared to untreated mice after eight weeks of UVB exposure.⁹ Human clinical trials evaluating the effectiveness of topical ellagic acid as a preventive or reactionary treatment for photodamage are needed.

Hyperpigmentation

Tyrosinase is a copper-containing enzyme that is key in melanin production.¹⁰ Ellagic acid decreases melanogenesis by inhibiting tyrosinase through copper chelation at the active site.¹⁰ Two *in vivo* studies suggest that ellagic acid may be effective in treating hyperpigmentation (Table 5.1).^{10,11} Shimogaki et al. reported that topically applied ellagic acid (1% w/v) improved UV-induced pigmentation in brownish

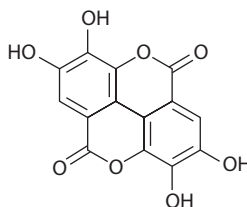

FIGURE 5.1 The structure of ellagic acid.

TABLE 5.1

Summary Data of Studies Investigating the Use of Ellagic Acid in Dermatology

Study	Agent	Study Type and Population	Outcome Measurements	Main Results and Adverse Events
<i>UV-Induced Skin Aging</i>				
Bae 2010, Korea	Ellagic acid (10 $\mu\text{mol/L}$ in 100 μL acetone), topical, every day for 8 weeks vs. Control (no treatment)	Animal study N = 18 SKH-1 hairless mice (6 not irradiated, 12 exposed to chronic UVB radiation for 8 weeks)	1. Skin-visiometer for evaluating skin roughness, smoothness, and scaliness 2. Histological staining with masson-trichrome for dermal collagen fibers 3. H&E staining to measure skin epidermal thickening	Less roughness/scaliness, greater smoothness, stronger staining of collagen fibers, and reduced epidermal thickness in ellagic acid group compared with control
<i>Hyperpigmentation</i>				
Dahl 2013, USA	Ellagic acid 0.5% + salicyclic acid 0.1%, topical, BID for 12 weeks vs. Hydroquinone 4%, topical, BID (twice daily) for 12 weeks	Human, randomized, double-blind N = 54 multiethnic patients with mild to moderate dark spots/sun spots/hyperpigmentation, uneven skin tone, loss of firmness/elasticity (27 in each group)	1. Clinical grading of hyperpigmentation, lightening, radiance, skin tone, overall facial appearance, overall facial imperfections 2. Clinical grading of age spots (size and count) 3. Chroma meter for L (luminance) value Values measured at baseline, weeks 4, 8, 12	Significant improvement in all clinical attributes, decrease in spot size and count, and improvement in skin lightening in pigmented age spots in both groups after 12 weeks No significant adverse events
Ertam 2008, Turkey	Synthetic ellagic acid 1%, topical, BID for up to 6 months vs. Natural ellagic acid 1%, topical, BID for up to 6 months vs. Arbutin 1%, topical, BID for up to 6 months	Human, randomized, open-label N = 30 melasma patients (10 in each study group)	1. Mexameter for pigment density before and after treatment 2. Follow-up for at least 6 months	Significant decrease in pigment density seen in all groups; no significant difference between groups No significant adverse events

TABLE 5.1 (Continued)

Summary Data of Studies Investigating the Use of Ellagic Acid in Dermatology

Study	Agent	Study Type and Population	Outcome Measurements	Main Results and Adverse Events
				<i>(Continued)</i>
Kasai 2006, Japan	Pomegranate extract (89.5% ellagic acid) High-dose ellagic acid, 200 mg/day PO vs. Low-dose ellagic acid, 100 mg/day PO vs. Control (placebo)	Human, randomized, double- blind, placebo-controlled N = 39 females (13 in each study group, all received UV radiation on inside of arm)	1. Spectrocolorimeter for L value 2. Mexameter for melanin and erythema values Values measured at baseline, wks 1, 2, 3, 4	Stratified analysis using subjects with slight sunburn show significant inhibition of pigmentation in low-dose group at weeks 1, 2, and 4, and in high-dose group at weeks 2 and 3; no significant change in melanin value and erythema value between study groups
Yoshimura 2005, Japan	Pomegranate extract (90.16% ellagic acid) Pomegranate extract, 100 mg/kg/day PO for 35 days vs. Pomegranate extract, 1,000 mg/kg/day PO for 35 days vs. L-ascorbic acid, 600 mg/kg/day PO for 35 days vs. Control (water only)	Animal Study N = 24 brownish guinea pigs (6 in each group, UVB radiation on days 7, 9, 11)	1. Reflectance spectrophotometer for L value	Pigmentation reduced in pomegranate extract group and L-ascorbic acid group, but not control; pomegranate extract shows dose-dependent pigmentation inhibitory effect; no significant difference between experimental groups

guinea pigs after four weeks of daily treatment.¹⁰ Yoshimura et al. demonstrated that oral administration of ellagic acid-rich pomegranate extract (100 mg/kg/day versus 1000 mg/kg/day) inhibited UV-induced pigmentation, in a dose-dependent manner, among brownish guinea pigs.¹¹

Moreover, several human clinical trials have examined the effectiveness of ellagic acid in treating hyperpigmentation (Table 5.1).^{12–14} A randomized, double-blind, placebo-controlled trial found that orally administered ellagic acid-rich pomegranate acid tablets (100–200 mg/day) significantly inhibited pigmentation among subjects with a slight sunburn caused by UV irradiation.¹² Ertam et al. compared the effectiveness of synthetic 1% ellagic acid, naturally-derived 1% ellagic acid, and 1% arbutin in treating melasma in a randomized, open-label study.¹³ Both formulations of ellagic acid were as effective as arbutin, a well-known skin lightening agent, in improving pigment density.¹³ A recent study reported that topical 0.5% ellagic acid and 0.1% salicylic acid combination therapy was as effective as 4% hydroquinone in improving several clinical and instrumental measures of pigmentation.¹⁴

Side Effects

Clinical studies have not reported any adverse events with topical application of ellagic acid.^{13,14}

Conclusion

Ellagic acid may have several dermatological applications. Limited available evidence suggests that ellagic acid may reduce UV-induced skin wrinkling *in vivo*.⁹ Additional studies are needed to characterize the clinical effectiveness of ellagic acid as a preventive or reactionary treatment for premature photoaging.

Furthermore, several studies suggest that topical and oral forms of ellagic acid may be effective in preventing and treating hyperpigmentation.^{10–14} Although hydroquinone is considered the standard treatment, it may be melanotoxic and can cause permanent skin depigmentation.¹⁰ Ellagic acid has not been found to damage melanocytes and may be a safe alternative agent.¹⁰

REFERENCES

1. Kim YH, Kim KH, Han CS et al. Anti-wrinkle activity of *Platycarya strobilacea* extract and its application as a cosmeceutical ingredient. *J Cosmetic Sci* 2010;61:211–24.
2. Usta C, Ozdemir S, Schiariti M, Puddu PE. The pharmacological use of ellagic acid-rich pomegranate fruit. *Int. J Food Sci Nutr* 2013;64:907–13.
3. Larrosa M, Tomas-Barberan FA, Espin JC. The dietary hydrolysable tannin punicalagin releases ellagic acid that induces apoptosis in human colon adenocarcinoma Caco-2 cells by using the mitochondrial pathway. *J Nutr Biochem* 2006;17:611–25.
4. Weisburg JH, Schuck AG, Reiss SE et al. Ellagic acid, a dietary polyphenol, selectively cytotoxic to HSC-2 oral carcinoma cells. *Anticancer Res* 2013;33:1829–36.
5. Zhao M, Tang SN, Marsh JL, Shankar S, Srivastava RK. Ellagic acid inhibits human pancreatic cancer growth in Balb c nude mice. *Cancer Lett* 2013;337:210–7.
6. Qiu Z, Zhou B, Jin L et al. *In vitro* antioxidant and antiproliferative effects of ellagic acid and its colonic metabolite, urolithins, on human bladder cancer T24 cells. *Food Chem Toxicol* 2013;59:428–37.
7. Cozzi R, Ricordy R, Bartolini F, Ramadori L, Perticone P, De Salvia R. Taurine and ellagic acid: Two differently-acting natural antioxidants. *Environ Mol Mutagen* 1995;26:248–54.
8. Iino T, Nakahara K, Miki W et al. Less damaging effect of whisky in rat stomachs in comparison with pure ethanol. Role of ellagic acid, the nonalcoholic component. *Digestion* 2001;64:214–21.
9. Bae JY, Choi JS, Kang SW, Lee YJ, Park J, Kang YH. Dietary compound ellagic acid alleviates skin wrinkle and inflammation induced by UV-B irradiation. *Exp Dermatol* 2010;19:e182–90.
10. Shimogaki H, Tanaka Y, Tamai H, Masuda M. *In vitro* and *in vivo* evaluation of ellagic acid on melanogenesis inhibition. *Int J Cosmetic Sci* 2000;22:291–303.

11. Yoshimura M, Watanabe Y, Kasai K, Yamakoshi J, Koga T. Inhibitory effect of an ellagic acid-rich pomegranate extract on tyrosinase activity and ultraviolet-induced pigmentation. *Biosci Biotechnol Biochem* 2005;69:2368–73.
12. Kasai K, Yoshimura M, Koga T, Arai M, Kawasaki S. Effects of oral administration of ellagic acid-rich pomegranate extract on ultraviolet-induced pigmentation in the human skin. *J Nutr Sci Vitaminol* 2006;52:383–8.
13. Ertam I, Mutlu B, Unal I, Alper S, Kivcak B, Ozer O. Efficiency of ellagic acid and arbutin in melasma: A randomized, prospective, open-label study. *J Dermatol* 2008;35:570–4.
14. Dahl A, Yatskayer M, Raab S, Oresajo C. Tolerance and efficacy of a product containing ellagic and salicylic acids in reducing hyperpigmentation and dark spots in comparison with 4% hydroquinone. *J Drugs in Dermatol* 2013;12:52–8.
15. Hseu YC, Chou CW, Senthil Kumar KJ et al. Ellagic acid protects human keratinocyte (HaCaT) cells against UVA-induced oxidative stress and apoptosis through the upregulation of the HO-1 and Nrf-2 antioxidant genes. *Food Chem Toxicol* 2012;50:1245–55.

6

Gamma-Linolenic Acid–Containing Vegetable Oils

Reto Muggli

Introduction

The skin, covering an area of 1.5 m² and weighing several kilograms, is man's largest organ. It is an important beauty attribute that determines to a large extent how others perceive us and how we perceive ourselves, and it protects the body from dehydration, mechanical insults, and environmental stressors.

Lipids have varied functions in the skin. Different classes of skin lipids of diverse complexity have been identified: free fatty acids, triglycerides, sterols, waxes, ceramides, fat soluble vitamins, phospholipids, and others. Disturbances in skin lipid composition and metabolism often manifest themselves as skin problems.

Metabolism and Cutaneous Significance of Linoleic and Gamma-Linolenic Acid

Epidermal hyperproliferation and increased water loss through the skin are lead symptoms in experimental and clinical fatty acid deficiency states and were key observations in the discovery of the essentiality of unsaturated fatty acids and linoleic acid (LA) in man. LA applied systemically or topically is known to regenerate a defective skin barrier in animals and in humans deficient in essential fatty acids.¹

Unsaturated and saturated fatty acids are components of keratinocyte and matrix lipids.² Besides sterols and free fatty acids, the chief constituent of intracellular stratum corneum lipids are ceramides. LA is the most abundant polyunsaturated fatty acid in skin and has a specific role in maintaining a functional epidermal water permeability barrier of the stratum corneum. Up to 50% of LA in the epidermis is bound to ceramide-1, one of the several cutaneous ceramides that have been described.

It is thought that LA deficiency disrupts the stacked lipid bilayers surrounding the corneocytes of the horny layer, causing breakdown of the barrier function.³ In addition to a direct structural role, LA may also be acting through its metabolite 13-HODE (13-hydroxy-9,11-octadecadienoic acid), a major hydroxyl fatty acid in normal epidermis. Topical application of 13-HODE in an animal model of hyperproliferation reversed the hyperproliferation to a normal state⁴ supporting the view that 13-HODE may represent the endogenous cutaneous mediator necessary for full restoration of cutaneous symptoms of essential fatty acid deficiency.

While the importance of LA for skin health is recognized, the role of gamma-linolenic acid (GLA) is much less appreciated. GLA is an omega-6 (n-6) polyunsaturated fatty acid with 18 carbon atoms and three double bonds and represents the first product of the n-6 polyunsaturated fatty acid pathway (Figure 6.1). In mammals, GLA is converted from LA by the action of a rate-limiting enzyme, delta-6-desaturase (D6D). Once formed, GLA is rapidly elongated to dihomo-gamma-linolenic acid (DGLA), 20:3n-6, by the activity of a polyunsaturated fatty acid specific elongase. DGLA can be further converted to arachidonic acid (ARA), 20:4n-6, by the action of delta-5-desaturase. Both DGLA and ARA can be metabolized to eicosanoids, hormone-like mediators of epidermal inflammation and immune functions.^{5,6}

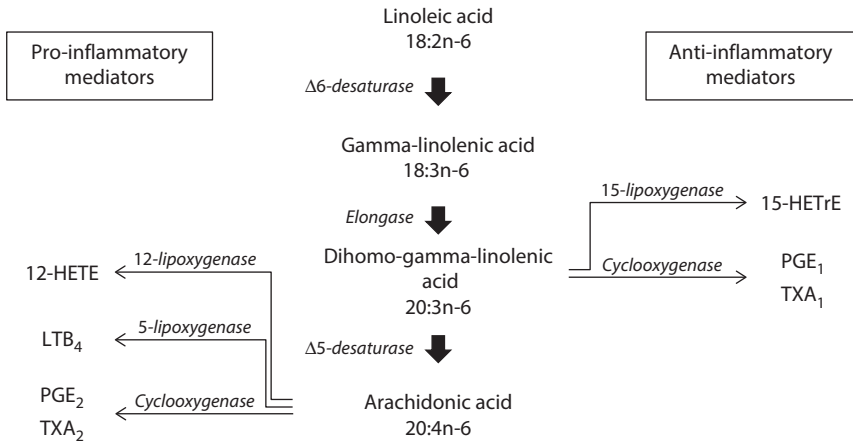

FIGURE 6.1 Biosynthesis and metabolism of gamma-linolenic acid.

GLA-Rich Vegetable Oils and Skin Health

GLA-rich vegetable oils have been evaluated in a variety of clinical conditions.^{7,8} The oils have been reported to have a skin barrier repairing effect, to normalize excessive transepidermal water loss (TEWL), and to improve mechanical and smoothness parameters after topical or systemic administration to healthy and irritated skin. In some skin diseases GLA-rich vegetable oils were found to have preventative or ameliorative effects. These observations suggest that GLA is important in the maintenance of skin health.

Animal Studies

In animal models, injury to the skin barrier—manifested by an increased TEWL—and other skin changes as the result of a fatty acid deficient diet or from application of a lipid disrupting detergent could be reversed by oral treatment with GLA-rich vegetable oils.^{9–11} Borage (BO) and evening primrose (EPO) oil reversed experimental epidermal hyperproliferation in guinea pigs.¹² Ingestion of GLA-rich vegetable oils raised GLA and DGLA in various tissues, whereby the tissue levels of GLA and the size of the GLA-related biological effects seemed to depend not only on the absolute amount of GLA ingested but also on the source of GLA. For example, although the GLA concentration of GLA in BO is three times that of EPO, comparable amounts of PGE₁ (an anti-inflammatory metabolite of DGLA) have been detected in peritoneal macrophages of mice fed equal amounts of the oils.¹³ Similarly, in an effort to determine if the absolute level of GLA is the sole determinant of biological activity or whether the positional distribution contributes to the outcome, guinea pigs with essential fatty acid (EFA) deficiency-induced epidermal hyperproliferation were fed comparable amounts of GLA in the form of EPO or BO for two weeks. Epidermal hyperproliferation was more strongly reversed by BO than EPO, and group BO had higher levels of DGLA and ceramides than group EPO.¹² These findings may be ascribed to the fact that oils from different sources differ with respect to the stereospecific distribution of GLA in triacylglycerol.¹⁴ GLA is concentrated in the sn-3 position of EPO and blackcurrant seed oil, the sn-2 position of BO, and the sn-2 and sn-3 position of fungal oils. It has been hypothesized that the bioavailability of GLA differs depending on the stereochemical position of the fatty acid.

Clinical Evaluation

Dry or Sensitive Healthy Skin

Dry skin is a common complaint from women and men alike. The condition is the result of an impaired barrier function resulting in an excessive loss of water through the skin. This inability to retain moisture

TABLE 6.1

Clinical Studies Showing Benefits of GLA for Normal and Experimentally Irritated Healthy Skin

Application	GLA Source	Skin Condition
Topical	Borage oil	Normal skin ¹⁶
	Borage oil	Irritated skin ¹⁶
	Evening primrose oil	Normal skin ⁴⁸
Oral	Evening primrose oil	Normal skin ⁴⁹
	Evening primrose oil	Irritated skin ⁵⁰
	Borage oil	Normal skin ⁵¹
	Borage oil	Normal skin ⁵²
	Borage oil	Irritated skin ⁵³

causes the skin to look dull and flaky, feel rough, and lose elasticity.¹⁵ Dry skin can be due to genetic and metabolic factors and certain conditions such as dermatitis, eczema, or seborrhea.

Several intervention studies with topically or systemically applied EPO or BO have clearly shown to benefit healthy skin (Table 6.1). GLA-rich vegetable oils have been reported to have a skin barrier repairing effect, to normalize excessive TEWL, and to improve several biophysical skin parameters that serve as a measure for skin structure and function. The study by Nissen et al. deserves special mention.¹⁶ It is the only study, so far, that attempted to exclude rigorously possible confounding effects of LA. LA is present in all GLA-containing vegetable oils and has skin care and skin restorative properties. Thus, the benefits of EPO and BO could theoretically stem from the LA in these oils. The study compared a topical formulation with 3% BO (37% LA) against a formulation with 3% safflower oil (75% LA). The study revealed that application of a cream with BO strongly improves moisture content, skin roughness, and TEWL on SDS-damaged skin—more than either a cream with LA-rich safflower oil or the base emulsion alone.

Atopic Eczema

One important etiologic factor in atopic eczema is a defect of the epidermal water barrier. The skin of atopic eczema patients has a significantly lower content of ceramide-1. In addition, oleic acid has been shown to replace partially LA, leading to structural alterations of the lipid lamellae.

In atopic eczema, systemic long-range adjuvant treatment with EPO has been shown to be effective. Morse and Clough¹⁷ analyzed 26 randomized, placebo-controlled clinical trials of Efamol® EPO oil in atopic eczema including 1207 patients. The meta-analysis focused on itch and dryness as the variables of primary interest. Efamol EPO was found to be a safe and effective remedy for symptomatic relief of atopic eczema with simultaneous benefits on itch/pruritus, crusting, edema, and redness (erythema) that become apparent between four and eight weeks after treatment is initiated. The magnitude of the effects appeared to be reduced with concomitant topical steroid cream usage.

In contrast, a more recent meta-analysis of clinical studies to assess the effects of EPO and BO in atopic eczema found no positive results and triggered a controversy on the possible benefits of GLA in this skin condition.¹⁸ No significant improvement in global eczema scores as measured by both participants and their doctors were found. Published in the Cochrane Library, the study reportedly included all randomized, controlled trials with parallel or crossover design, investigating oral intake of EPO or BO for diagnosed eczema and related symptoms in children and adults published up to August 2012. The meta-analysis included 27 studies with 1596 participants and measured no significant improvement in Global Score.

One might speculate on why the two reports arrived at different conclusions. Whereas Morse and Clough analyzed 26 studies conducted exclusively with EPO, Bamford et al. looked at a total of 27 studies of which only 19 were EPO studies, the remaining eight used BO as the active treatment and these may not necessarily be classed as the same. The GLA in EPO is primarily in the sn-3 position, and would

be cleaved off the triglyceride during digestion and hence find its way into the metabolic pool. BO, on the other hand, has much more GLA at the sn-2 position, which would tend to be absorbed as the 2-mono-glyceride and hence be directed into phospholipids and hence membranes. An alternative hypothesis is that the very high levels of linoleic acid in EPO compared to BO are in some way influencing the way in which the body handles the GLA as TEWL and severity of AD were reported to be negatively correlated with serum levels of LA metabolites.¹⁹

A series of studies over the last decades pointed to the existence of fatty acid profile abnormalities in atopics.^{20,21} Plasma and serum levels of LA were found to be normal or higher, whereas levels of GLA, DGLA, and ARA tended to be lower. Similar findings have been reported in peripheral blood monocytes in atopic asthma and allergic rhinitis sufferers²² and in umbilical cord blood in infants at risk of atopy, where the biochemical abnormality is proportional to the IgE levels.²³ Though these deviations in fatty acid composition are not consistently observed and show considerable variations, they raised the speculation that atopics suffer from a deficiency or downregulation of D6D, the enzyme that converts LA to GLA (Figure 6.2). Recently, polymorphisms in the fatty acid desaturase (FADS) gene cluster (producing D6D and D5D) have been associated with atopic diseases.²⁴ These abnormalities of lipid production together with decreased production of ceramides, especially ceramide-1, are possibly the main cause for the defective epidermal water barrier that is regularly observed in atopics. Breast milk of atopic women has been reported to have low levels of LA metabolites in breast milk compared with healthy mothers.^{25–27} Children with atopic eczema show significantly lower levels of GLA and DGLA and these were found to correlate with the severity of the disease.¹⁹

Several studies have investigated GLA-rich vegetable oil for prevention of atopic eczema in newborns and children, often the first visible sign of atopic allergy in infants. The fetal period and the first 12 months after birth are decisive for immune function maturation, and polyunsaturated fatty acids (PUFA) and their metabolites are important in programming the development of the immune system.^{28,29} Therefore, early supplementation with PUFA could modulate immune function and affect the development of atopic eczema. In a double-blind placebo-controlled study, formula-fed infants with a maternal history of atopic disease were given BO supplements or placebo for the first six months of life.³⁰ The supplementation with GLA in these children at high familial risk tended to alleviate the severity of atopic eczema at the age of one year, but it did not prevent the expression of atopy as reflected by total serum IgE. In a double-blind placebo-controlled trial, alpine currant (*Ribes alpinum*) seed oil supplementation to pregnant and breastfeeding mothers and to their infants after weaning resulted in a transient lower prevalence of atopic eczema at the age of 12 months but not at 24 months.³¹ The symptoms of atopic eczema were less severe in the currant oil group than in the olive oil control group. The results are in line with those of a double-blind placebo-controlled trial in which the intensity of dermatitis symptoms of atopic children aged between six months and 4.5 years were less severe compared with those seen with rapeseed oil placebo.³² In conclusion, GLA-rich oils might have a role in pre- and postnatal nutrition as safe tools to mitigate or prevent atopic eczema in newborns and infants, particularly for those at high risk.

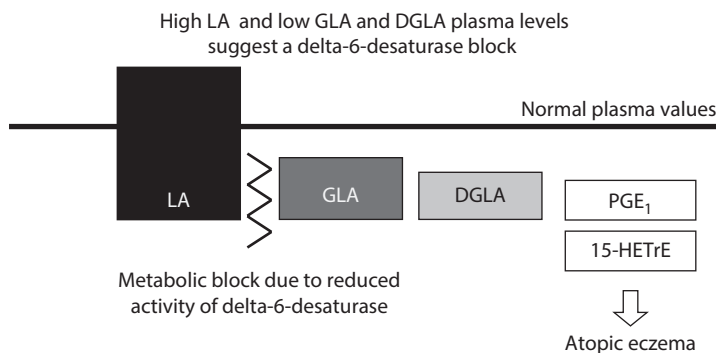

FIGURE 6.2 Atopic eczema.

Other Skin Problems

Tolleson and Frithz³³ studied topically applied BO in 37 children with clinically diagnosed infantile seborrheic dermatitis in an attempt to establish the significance of TEWL and water content in the stratum corneum, in active disease, and after recovery. With this regimen the children were completely free from all skin symptoms within 3–4 weeks. Twenty-five healthy children in an age-matched group without skin disorders were used as controls. Significant differences in TEWL existed between patients and controls before treatment. After treatment no significant differences were found. The authors suggested GLA to be of importance in maintaining normal TEWL and also in promoting recovery in patients suffering from infantile seborrheic dermatitis.

Sources of GLA

GLA is not common in fats and oils of vegetable or animal origin. Of the over 30 higher plant species in which the content of GLA in the oil exceeds 5%, only species from three genera are grown specifically as a source of GLA: *Borago*, *Oenothera*, and *Echium*. The seeds of blackcurrant (*Ribes nigrum*) are of minor commercial importance, they are a by-product of the fruit processing industry. Early attempts to develop GLA-rich yeasts and other fungal strains or cyanobacteria for fermentation appear to have been given up. A newer development is the high-level production of GLA in genetically modified seed crops, notably canola (*Brassica napus*) and safflower (*Carthamus tinctoria*). Table 6.2 lists the oil and GLA content of commercially important or potentially promising sources.

Mechanism of Action

The mechanism by which GLA exerts its skin health benefits is only partly understood. GLA has been reported to be particularly effective in conditions conducive toward local inflammation or where a disposition toward inflammation prevails.

Atopic eczema has a vigorous inflammatory component that contributes to redness and itching of the affected skin parts. Similarly, disruption of the permeability barrier in dry but healthy skin by chronic irritation of environmental and lifestyle stressors is invariably accompanied by an inflammation response.³⁴ Experimentally, mechanical, chemical, or UV-induced stress has been shown to disrupt the cutaneous permeability barrier, to increase TEWL, to cause hyperproliferation of the skin, and to trigger the production of inflammatory epidermal cytokines such as TNF and IL-1.^{35–37} In winter, cold increases TEWL and can strip the skin of moisture, which combined with low humidity and indoor heating can

TABLE 6.2

Oil and GLA Content of Commercially Important GLA Sources⁵⁴

Species	Oil (%)	GLA (%)
<i>Boraginaceae</i>		
<i>Borago officinalis</i>	28–31	17–25
<i>Echium vulgare</i>	22	11
<i>Onagraceae</i>		
<i>Oenothera biennis</i>	17–25	7–10
<i>Oenothera grandiflora</i>	4	9
<i>Saxifragaceae</i>		
<i>Ribes nigrum</i>	30	15–19
<i>Brassicaceae</i>		
<i>Brassica napus</i> (transgenic)		43
<i>Asteraceae</i>		
<i>Carthamus tinctorius</i> (transgenic) (Arcadia Biosciences)	29–37	40–60

cause dryness, and even cracking and chapping. Low humidity amplifies the hyperproliferative and inflammatory response to barrier disruption and may explain the seasonal exacerbation of dry skin and cutaneous disorders such as atopic eczema and psoriasis.

The prevailing theory behind the health benefits of GLA is that this fatty acid through its metabolite DGLA mitigates inflammation. GLA is rapidly and efficiently transformed to DGLA by cyclooxygenase to metabolites with potent anti-inflammatory activity such as prostaglandin E₁ and 15-hydroxy-eicosatrienoic acid (15-HETrE).^{3,38,39} Furthermore, GLA suppresses, at least *in vitro*, the formation or release of IL-1 β and TNF- α , both important pro-inflammatory mediators.⁵ Alternatively, DGLA can be metabolized to ARA, the precursor of eicosanoids that are mostly pro-inflammatory.⁴⁰ Thus, DGLA is the starting point of both a pro-inflammatory and an anti-inflammatory axis. There is evidence that in humans and rodents the activity of 5D5 is slow and only fractions of DGLA are converted to ARA.⁴¹ At least in inflammatory cells such as the neutrophil the majority of DGLA appears to be channeled towards prostaglandin E₁ and 15-HETrE formation. The increase in DGLA-derived eicosanoids relative to ARA metabolites may represent a mechanism by which dietary GLA tips the balance toward a less aggressive inflammatory response in acute and chronic cutaneous inflammations.

Irritation of skin—alone or on top of a restricted metabolism of LA to GLA—may not only disrupt the skin barrier but may induce predisposed skin to inflammatory overreactions, i.e., the skin reacts readily to minor insults with an overshooting or chronic inflammatory response. Similarly, the inflammatory component of atopic eczema, psoriasis, and other skin affections might be in part the result of inadequate amounts of prostaglandin E₁ and 15-HETrE due to the lack of the substrate GLA.^{5,9,10} PGE₁ is notoriously low in atopic eczema sufferers. The shortage of PGE₁ promotes the release of histamine and other mediators from inflammatory cells, such as leukocytes, mast cells, and basophilic granulocytes, aggravates the allergy inflammation reaction. The vicious circle may probably be maintained, as histamin itself is immunosuppressive and inhibits D6D. Furthermore, apart from its anti-allergic and anti-inflammatory activity, PGE₁ has a marked immunoregulatory role. Shortness of PGE₁ results in a functional weakness of T-cell function, characterized by poor T-cell maturation and differentiation, which may explain vulnerability of atopic eczema patients for bacterial infections. Of particular importance is the impaired regulation of B-lymphocytes, the cells that are at least partially responsible for the often-observed excessive IgE-response and the IgE concentrations function in the serum. However, abnormal omega-6 PUFA metabolism is neither consistently found nor is it specifically associated with atopic eczema but rather may be associated with IgE production and atopy in general.⁴²

If low GLA levels predispose skin to overshooting inflammation, oral or topical substitution of GLA could compensate epidermal deficits in this fatty acid. Strictly speaking, GLA is not a dietary essential fatty acid as humans can synthesize the molecule from LA via D6D. However, although LA deficiency is virtually non-existent in industrialized societies, the skin may still be undersupplied with GLA. The conversion of LA to GLA by D6D is generally a slow step. Furthermore, D6D is a very susceptible enzyme whose activity can be impaired genetically, by age, as well as by several nutritional deficiencies and lifestyle habits.^{7,43–45} Such physiological and pathological conditions that interfere with the bioconversion of LA lower body pools of GLA and its metabolites. Thus, the body, even in the presence of adequate dietary LA, may produce insufficient amounts of GLA. The skin is particularly sensitive to suboptimal GLA supply as it lacks the necessary D6D enzyme with which to form it *in situ*. Thus, the formation of skin GLA from LA must take place in other body tissues, notably the liver, from which the fatty acid is transported to the skin. Clearly, the skin is an organ that seems to depend on the supply of preformed GLA.

Kawashima et al. provided evidence that GLA acts through its metabolite DGLA.⁴⁶ Oral administration of DGLA markedly suppressed atopic eczema-like skin lesions in a mouse model for atopic eczema. Clinical skin severity scores were significantly and dose-dependently lower in mice fed DGLA compared to control animals. Scratching behavior and plasma total IgE levels were also reduced in the DGLA group, in parallel with histological improvement. DGLA levels in the skin, spleen, and plasma were increased. Discontinuation of DGLA administration led to a flare-up of dermatitis and a decrease in DGLA contents in the skin, spleen, and plasma. These findings indicate that oral administration of DGLA effectively prevents the development of atopic eczema in this mouse model, and that DGLA in phospholipids is possibly a compound of key importance in the development and prevention of dermatitis.

Further evidence for the pivotal role of D6D in the maintenance of a healthy skin was the finding that D6D knockout mice develop severe ulcerative dermatitis despite abundant LA in tissues. Skin prostaglandin D₂, a modulator of skin reaction to irritants, was decreased to 10% of the wild type controls.⁴⁷

Conclusions

Patients at risk of or with a chronic skin disease with an inflammatory component such as atopic eczema, psoriasis, or seborrheic dermatitis could benefit from topical or systemic adjuvant treatment with GLA-rich vegetable oils. Similarly, in stressed healthy skin, EPO and BO have a skin barrier repairing effect, normalize excessive TEWL, and improve several biophysical skin parameters. The effects appear to be mediated through anti-inflammatory metabolites of GLA.

REFERENCES

1. Hansen HS, Jensen B. Essential function of linoleic acid esterified in acylglucosylceramide and acylceramide in maintaining the epidermal water permeability barrier. Evidence from feeding studies with oleate, linoleate, arachidonate, columbinatate and alpha-linolenate. *Biochim Biophys Acta* 1985;834:357–63.
2. Feingold KR. The outer frontier: The importance of lipid metabolism in the skin. *J Lipid Res* 2009;50(Suppl):S417–22.
3. Wertz PW, Swartzendruber DC, Abraham W et al. Essential fatty acids and epidermal integrity. *Arch Dermatol* 1987;123:1381–4.
4. Miller CC, Ziboh VA. Induction of epidermal hyperproliferation by topical n-3 polyunsaturated fatty acids on guinea pig skin linked to decreased levels of 13-hydroxyoctadecadienoic acid (13-hode). *J Invest Dermatol* 1990;94:353–8.
5. Ziboh VA, Miller CC, Cho Y. Metabolism of polyunsaturated fatty acids by skin epidermal enzymes: Generation of antiinflammatory and antiproliferative metabolites. *Am J Clin Nutr* 2000;71(1 Suppl):361S–6S.
6. Calder PC, Yaqoob P, Thies F et al. Fatty acids and lymphocyte functions. *Br J Nutr* 2002;87(Suppl 1):S31–48.
7. Horrobin DF. Gamma-linolenic acid: An intermediate in essential fatty acid metabolism with potential as an ethical pharmaceutical and as a food. *Rev Contemp Pharmacother* 1990;1:1–45.
8. Barre DE. Potential of evening primrose, borage, black currant, and fungal oils in human health. *Ann Nutr Metab* 2001;45:47–57.
9. Chapkin RS, Ziboh VA, McCullough JL. Dietary influences of evening primrose and fish oil on the skin of essential fatty acid-deficient guinea pigs. *J Nutr* 1987;117:1360–70.
10. Hartop PJ, Prottey C. Changes in transepidermal water loss and the composition of epidermal lecithin after applications of pure fatty acid triglycerides to skin of essential fatty acid-deficient rats. *Br J Dermatol* 1976;95:255–64.
11. Ziboh VA, Chapkin RS. Biologic significance of polyunsaturated fatty acids in the skin. *Arch Dermatol* 1987;123:1686a–90.
12. Chung S, Kong S, Seong K et al. Gamma-linolenic acid in borage oil reverses epidermal hyperproliferation in guinea pigs. *J Nutr* 2002;132:3090–7.
13. Fan YY, Chapkin RS. Mouse peritoneal macrophage prostaglandin E1 synthesis is altered by dietary gamma-linolenic acid. *J Nutr* 1992;122:1600–6.
14. Lawson LD, Hughes BG. Triacylglycerol structure of plant and fungal oils containing γ -linolenic acid. *Lipids* 1988;23:313–7.
15. Farage MA, Maibach HI. Sensitive skin: Closing in on a physiological cause. *Contact Dermatitis* 2010;62:137–49.
16. Nissen HP, Biltz H, Muggli R. Borage oil. Gamma-linolenic acid decreases skin roughness and TEWL and increases skin moisture in normal and irritated human skin. *Cosmetics Toiletries* 1995;110:71–4.
17. Morse NL, Clough PM. A meta-analysis of randomized, placebo-controlled clinical trials of Efamol evening primrose oil in atopic eczema. Where do we go from here in light of more recent discoveries? *Curr Pharm Biotechnol* 2006;7:503–24.

18. Bamford JT, Ray S, Musekiwa A et al. Oral evening primrose oil and borage oil for eczema. *Cochrane Database Syst Rev* 2013;4:CD004416.
19. Yen CH, Dai YS, Yang YH et al. Linoleic acid metabolite levels and transepidermal water loss in children with atopic dermatitis. *Ann Allergy Asthma Immunol* 2008;100:66–73.
20. Oliwiecki S, Burton JL, Elles K et al. Levels of essential and other fatty acids in plasma and red cell phospholipids from normal controls and patients with atopic eczema. *Acta Derm Venereol* 1991;71:224–8.
21. Manku MS, Horrobin DF, Morse NL et al. Essential fatty acids in the plasma phospholipids of patients with atopic eczema. *Br J Dermatol* 1984;110:643–8.
22. Rocklin RE, Thistle L, Gallant L et al. Altered arachidonic acid content in polymorphonuclear and mononuclear cells from patients with allergic rhinitis and/or asthma. *Lipids* 1986;21:17–20.
23. Strannegård IL, Svennerholm L, Strannegård O. Essential fatty acids in serum lecithin of children with atopic dermatitis and in umbilical cord serum of infants with high or low IgE levels. *Int Arch Allergy Appl Immunol* 1987;82:422–3.
24. Lattka E, Illig T, Heinrich J et al. FADS gene cluster polymorphisms: Important modulators of fatty acid levels and their impact on atopic diseases. *J Nutrigenet Nutrigenomics* 2009;2:119–28.
25. Businco L, Ioppi M, Morse NL et al. Breast milk from mothers of children with newly developed atopic eczema has low levels of long chain polyunsaturated fatty acids. *J Allergy Clin Immunol* 1993;91:1134–9.
26. Laitinen K, Sallinen J, Linderborg K et al. Serum, cheek cell and breast milk fatty acid compositions in infants with atopic and non-atopic eczema. *Clin Exp Allergy* 2006;36:166–73.
27. Wright S, Bolton C. Breast milk fatty acids in mothers of children with atopic eczema. *Br J Nutr* 1989;62:693–7.
28. Enke U, Seyfarth L, Schleussner E et al. Impact of PUFA on early immune and fetal development. *Br J Nutr* 2008;100:1158–68.
29. Prescott SL, Dunstan JA. Prenatal fatty acid status and immune development: The pathways and the evidence. *Lipids* 2007;42:801–10.
30. van Gool CJ, Thijs C, Henquet CJ et al. Gamma-linolenic acid supplementation for prophylaxis of atopic dermatitis—A randomized controlled trial in infants at high familial risk. *Am J Clin Nutr* 2003;77:943–51.
31. Linnamaa P, Savolainen J, Koulu L et al. Blackcurrant seed oil for prevention of atopic dermatitis in newborns: A randomized, double-blind, placebo-controlled trial. *Clin Exp Allergy* 2010;40:1247–55.
32. Johansson A, Isolauri E, Salminen S et al. Alpine currant seed oil as a source of polyunsaturated fatty acids in the treatment of atopic eczema. In: Lásztity R, Pfannhauser W, Simon-Sarkadi L et al., eds. *Functional Foods—A New Challenge for the Food Chemists*. Budapest: Publishing Company of TUB; 1999. pp. 530–6.
33. Tolleson A, Frithz A. Transepidermal water loss and water content in the stratum corneum in infantile seborrhoeic dermatitis. *Acta Derm Venereol* 1993;73:18–20.
34. Mac-Mary S, Sainthillier JM, Humbert P. Dry skin and the environment. *Exog Dermatol* 2004;3:72–80.
35. Wood LC, Elias PM, Calhoun C et al. Barrier disruption stimulates interleukin-1 alpha expression and release from a pre-formed pool in murine epidermis. *J Invest Dermatol* 1996;106:397–403.
36. Wood LC, Jackson SM, Elias PM et al. Cutaneous barrier perturbation stimulates cytokine production in the epidermis of mice. *J Clin Invest* 1992;90:482–7.
37. Ansel JC, Luger TA, Lowry D et al. The expression and modulation of IL-1 alpha in murine keratinocytes. *J Immunol* 1988;140:2274–8.
38. DeLuca P, Rossetti RG, Alavian C et al. Effects of gammalinolenic acid on interleukin-1 beta and tumor necrosis factor-alpha secretion by stimulated human peripheral blood monocytes: Studies *in vitro* and *in vivo*. *J Investig Med* 1999;47:246–50.
39. Furse RK, Rossetti RG, Seiler CM et al. Oral administration of gammalinolenic acid, an unsaturated fatty acid with anti-inflammatory properties, modulates interleukin-1beta production by human monocytes. *J Clin Immunol* 2002;22:83–91.
40. Nakamura MT, Nara TY. Structure, function, and dietary regulation of delta6, delta5, and delta9 desaturases. *Annu Rev Nutr* 2004;24:345–76.
41. Wang X, Lin H, Gu Y. Multiple roles of dihomo- γ -linolenic acid against proliferation diseases. *Lipids Health Dis* 2012;11:25–33.
42. Focke M, Sesztak-Greinecker G, Brannath W et al. Plasma levels of polyunsaturated fatty acids in children with atopic dermatitis and in atopic and nonatopic controls. *Wien Klin Wochenschr* 2005;117:485–91.

43. Jones DB, Carter RD, Mann JI. Indirect evidence of impairment of platelet desaturase enzymes in diabetes mellitus. *Horm Metab Res* 1986;18:341–4.
44. Leng GC, Smith FB, Fowkes FG et al. Relationship between plasma essential fatty acids and smoking, serum lipids, blood pressure and haemostatic and rheological factors. *Prostaglandins Leukot Essent Fatty Acids* 1994;51:101–8.
45. Brenner RR. Nutritional and hormonal factors influencing desaturation of essential fatty acids. *Prog Lipid Res* 1981;20:41–7.
46. Kawashima H, Tateishi N, Shiraishi A et al. Oral administration of dihomo-gamma-linolenic acid prevents development of atopic dermatitis in NC/Nga mice. *Lipids* 2008;43:37–43.
47. Roqueta-Rivera M, Stroud CK, Segre M et al. Dietary arachidonic acid prevents ulcerative dermatitis and partially restores skin prostaglandin delta-6-desaturase (6D6) in knockout mouse. *8th ISSFAL Congress*, Kansas City, 2008: Poster P088.
48. Muggli R. Natural management of napkin rash. *Eur J Pediatr Dermatol* 2009;19:43–6.
49. Muggli R. Systemic evening primrose oil improves the biophysical skin parameters of healthy adults. *Int J Cosmet Sci* 2005;27:243–9.
50. Muggli R. Systemic evening primrose oil for irritated skin care. *Cosmetics Toiletries* 2007;122:49–56.
51. Brosche T, Platt D. Effect of borage oil consumption on fatty acid metabolism, transepidermal water loss and skin parameters in elderly people. *Arch Gerontol Geriatr* 2000;30:139–50.
52. Puch F, Samson-Villeger S, Guyonnet D et al. Consumption of functional fermented milk containing borage oil, green tea and vitamin E enhances skin barrier function. *Exp Dermatol* 2008;17:668–74.
53. De Spirt S, Stahl W, Tronnier H et al. Intervention with flaxseed and borage oil supplements modulates skin condition in women. *Br J Nutr* 2009;101:440–5.
54. Clough P. Sources and production of speciality oils containing GLA and stearidonic acid. *Lipid Technol* 2001;13:9–12.

7

Hexylresorcinol: Providing Skin Benefits by Modulating Multiple Molecular Targets

Ratan K. Chaudhuri

Background

Hexylresorcinol (HR) is an alkylresorcinol (AR), a type of phenolic lipid, having an n-hexyl chain attached to the 4 position of the 1,3-dihydroxybenzene ring (Figure 7.1). It can be synthesized by reacting resorcinol with hexanoyl chloride in the presence of Lewis acid catalyst. The resultant intermediate, hexanoylresorcinol, is then reduced to hexylresorcinol. Subsequent purification of HR is attained by, e.g., crystallization using suitable solvent(s).

Hexylresorcinol is an ingredient that has attained GRAS (Generally Recognized as Safe) status and is effective as an anti-browning agent for prevention of melanosis in shrimp.¹ HR has also been shown to be a very effective inhibitor of surface browning on many fresh-cut fruits, such as apples, pears, mangoes, etc.^{2,3} When combined with ascorbic acid, it has a synergistic effect in the prevention of browning. Here, ascorbic acid reduces quinones generated by polyphenoloxidase while HR specifically interacts with polyphenol oxidase, and renders it incapable of catalyzing the enzymatic reaction.^{4,5} A post-cutting dip of HR, ascorbic acid, and calcium lactate was found to extend the shelf-life of pear slices from 15 to 30 days.⁶ Similarly, Red Delicious apple slices treated with an anti-browning dip (HR, isoascorbic acid, N-acetyl cysteine, and calcium propionate) and held at 5°C maintained visual quality for five weeks.⁷ Although sulfites are more commonly used in controlling browning of foods, HR has several advantages over sulfites, including its specific mode of inhibitory action, effectiveness at low concentrations, inability to bleach preformed pigments, and chemical stability.

From a human physiological and biological perspective, HR is perhaps one of, if not the most studied and well-known AR. It is reported to have anesthetic, antiseptic, and anthelmintic properties⁸ and can be used topically, e.g., on small skin infections or as an ingredient in a consumable carrier, e.g., throat lozenges.⁹ As a throat lozenge it manifests both antiseptic and local anesthetic effects: its antiseptic action killing the bacteria that may be associated with a sore throat, while its anesthetic action helps relieve the pain associated therewith. Here, the action of sucking the lozenge allows the active ingredient to work in the area of the discomfort, and also helps to coat, lubricate, and soothe the irritated throat tissue.

ARs are also found in nature; alkyl chains C17:0–C25:0 attached to 5 position are abundant in whole-grain wheat and rye.¹⁰ ARs are reported to have antitumor, antibacterial, antifungal, and antiparasitic activities. These effects of ARs were attributed to membrane-modulating effects due to interactions of their alkyl tails with phospholipids and/or proteins and to antioxidant effects of the phenolic hydrogen.¹¹

HR has a long history of human use. The earliest citation to its use in humans appears to be that of Dr. Veader Leonard and his associates at the Johns Hopkins School of Hygiene and Public Health in Baltimore, Maryland.* As reported, Dr. Leonard and his associates were looking for a “perfect” antiseptic that was deadly to germs but harmless to man. In the course of their efforts, they found that HR possessed over 50 times the germ-killing power of pure carbolic acid.

* Cited by *Time Magazine*, Medicine: Hexylresorcinol, Monday February 23, 1925; obtained from <http://content.time.com/time/magazine/article/0,9171,719908,00.html>.

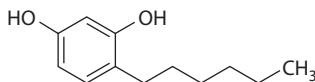

FIGURE 7.1 Structure of hexylresorcinol (HR).

Despite its long history of use as an antiseptic, anesthetic, and anthelmintic, it is only recently that its use and benefits as an active ingredient for skin care applications has been realized. In 2007, Sytheon Ltd. introduced HR as a cosmetic/skin care additive for use as a skin protectant having skin lightening and even-toning properties under the trade named Synovea® HR.¹² Its utility in this application is believed, in part, to arise from the ability to attain highly purified HR (>99%, typically ranging from 99.5% to 99.9%) which is essentially free of resorcinol, a known skin irritant, and hexanoylresorcinol, the intermediate.¹²

Focusing on the human physiological and biological properties of HR, attention will now be given to its antimicrobial, antitumor, anti-aging, and skin lightening/even-toning properties in particular.

Antimicrobial

On July 22, 1991, the U.S. Food and Drug Administration (FDA) published the *Tentative Final Monograph* for antimicrobial drug products—first aid antiseptics¹³—in which HR was identified as a category I antimicrobial ingredient. HR has been used extensively in antibacterial mouthwash and, as noted above, throat lozenges. Antibacterial mouthwashes are effective due to the presence of HR, which inhibits the growth and proliferation of microorganisms found in the mouth: thus preventing caries and ameliorating infectious conditions. As a side benefit, mouthwashes having HR also prevent or reduce halitosis, which, in many instances, is generated or arises from various microorganisms in the mouth. As noted above, lozenges such as Strepsils® Extra Blackcurrant Lozenges containing HR possess both antiseptic properties to fight bacterial throat infections and anesthetic properties to soothe and numb throat pain.

The emergence of pathogenic bacterial strains resistant to currently available antimicrobial agents continues to be a universal problem of ever increasing importance.¹⁴ Extensive efforts have been undertaken to validate new target enzymes for antimicrobials; however, these have met with little success,¹⁵ with the majority of successful drugs inhibiting just a handful of cellular processes. To date, one of the most successfully exploited drug targets has been the DNA topoisomerase (topo) class of enzymes. For example, recent studies by Taylor et al. have shown that HR has good DNA topoisomerase inhibitory activity (IC_{50} 30 μ M), which compares well with m-Amsacrine (30 μ M) and Purpurin (40 μ M).¹⁴

Chaudhuri has also demonstrated excellent antimicrobial activities of HR in an, as yet, unpublished work. Specifically, Chaudhuri conducted an evaluation to assess the minimum inhibitory concentration values (MIC in μ g/mL) of HR against various organisms relevant to personal care applications in accordance with U.S. Pharmacopeia's Compendia Products procedure for Category 2 (USP 26-87 pp. 2022–2026). The results are given in [Table 7.1](#).

In addition, Chaudhuri conducted a challenge test using 0.5% (w/w) level of HR in a lotion. The results showed a 3-log reduction of fungi, but not the desired reduction of bacteria. Nevertheless, it appears that HR can act as a synergist in combination with existing commercial antimicrobial ingredients.

Antitumor

HR has also found potential utility as an antitumor agent, particularly in relation to differentiation therapy. The signaling pathways related to cell differentiation and senescence fail to function properly in malignant tumor cells. As a result, tumor cells exhibit uncontrolled and invasive growth. Differentiation therapy is currently being considered as one of the key emerging techniques for the treatment of cancer.¹⁶ Kim et al. have recently shown that HR induces the differentiation of SCC-9 via the modulation of the E2F-mediated signaling pathway and suppressed the growth of SCC-9 cells in a dose-dependent

TABLE 7.1

Minimum Inhibitory Concentration Values (MIC in $\mu\text{g/mL}$) of HR against Various Organisms

Organisms	MIC Value ($\mu\text{g/mL}$)
Bacteria	
<i>E. coli</i>	2.5
<i>S. aureus</i>	4.5
<i>S. epidermidis</i>	4.5
<i>Streptococcus</i>	1.5
<i>Lactobacillus</i>	4.0
<i>P. gingivalis</i>	1.0
<i>P. acne</i>	25 to 50
Fungi	
<i>Aspergillus niger</i>	0.3
<i>Candida albicans</i>	3.5

manner.¹⁷ In this study, the authors also found that HR increased the expression of the epithelial cell differentiation markers involucrin and keratin 10.

Following on the foregoing, Kim and Choi have further demonstrated that HR dose-dependently induced SCC-9 cell apoptosis as determined by caspase-3 activity, annexin V expression, as well as by scanning and transmission electron microscopy.¹⁸ HR was shown to inhibit intracellular calcium oscillation in both SCC-9 cells and normal human dermal fibroblasts. HR-induced apoptosis was partly reversed by calcium channel blockers. Additionally, HR reduced the tumor mass formed by SSC-9 cell implantation in BALB/cAnNCrj-nu/nu mice and mass size reduction was also partly reversed by the concomitant application of calcium channel blockers. The results of this study suggest that HR is providing strong antitumor effects by inhibiting calcium channel oscillation and inducing apoptosis.¹⁸

Finally, the resistance to chemotherapy is very important in the prognosis of tumors. Transglutaminase-2 (TG-2) mediated chemotherapy resistance has been widely reported. TG-2 is overexpressed in many cancers such as breast cancer,¹⁹ malignant melanoma,²⁰ and glioblastoma²¹ and facilitates tumor spread and metastasis. Recently, Kim et al. reported on their finding of an inhibitory effect on TG-2 enzyme activity by HR.¹⁷ Additionally, when the authors compared the performance of a mixture containing 5 $\mu\text{g/mL}$ HR and 5 $\mu\text{g/mL}$ cisplatin (a common chemotherapy drug) to 10 $\mu\text{g/mL}$ of cisplatin alone on tumor cells, they found the application of the mixture resulted in significantly lower tumor cell viability than the cisplatin alone ($p < 0.05$). Accordingly, it is believed that HR has a synergistic effect on KB cell death when employed in combination with cisplatin. The authors also examined the effects of the combination of cisplatin and HR on oral mucosal melanoma (OMM) using cultured primary OMM cells in a tumor xenograft model. According to their findings, the combination resulted in fewer metastases and longer survival than cisplatin-only treatment in the OMM xenograft model.²² Based on these findings, it is now believed that HR could be a viable candidate as a chemotherapeutic agent in the treatment of cisplatin resistant tumors.

Anti-Aging

Recent findings also demonstrate the influence or impact of HR on a variety of processes involved in skin aging and damage, including oxidation, inflammation, and glycation.

Antioxidant

Although HR would not typically be expected to be an effective conventional antioxidant (radical and/or non-radical quencher) based on its structure²³; it may still be considered an antioxidant in a broader

sense because its metabolites, such as, 1,2,3-trihydroxy- and/or 1,3,5-trihydroxy-4-hexylresorcinols, can have potent radical and non-radical quenching activity.¹¹ Antioxidant activity may also be attributed to HR, though indirectly, as a result of its ability to stimulate the cell protectant glutathione and various antioxidant defense enzymes such as glutathione peroxidase and glutathione reductase.²⁴ For example, Yen et al. have demonstrated that HR has a protective effect against oxidative DNA damage in human lymphocytes induced by hydrogen peroxide.²⁴

Inflammation

Inflammation is a complex physiological process and the role of transcription factor NF-kappaB in the inflammatory response has been well documented.^{25,26} NF-kappaB is activated by numerous stimuli and once fully activated participates in the regulation of various target genes in different cells to exert its biological functions. NF-kappaB has often been referred to as a central mediator of the immune response since a large variety of bacteria and viruses can lead to the activation of NF-kappaB, which in turn controls the expression of many inflammatory cytokines, chemokines, immune receptors, and cell surface adhesion molecules.

Recently, Kim et al. reported that HR inhibited NF-kappaB phosphorylation.²⁷ Independently, Johnson & Johnson scientists found that HR has a stimulating effect on collagen and elastin synthesis through NF-kappaB inhibition.²⁸ Based on these findings, and the fact that inflammation has a significant effect on skin aging, it is anticipated that HR would provide an anti-inflammatory as well as anti-aging effect on skin when applied topically.

Glycation

Glycation is the term used for a class of non-enzymatic reactions that occurs between sugars, such as glucose or ribose, and proteins and lipids, including, e.g., the reaction between the nucleophilic amino group of proteins and a reducing sugar wherein the sugar becomes bonded to the protein. Glycation is the first of a series of reactions by which advanced glycation end-products (AGEs) are formed: the subsequent reactions include Schiff base reactions, Amadori reactions, and Maillard reactions. Though not all glycation reactions lead to AGEs, physiological and biological conditions will shift the reactions to favor or disfavor their formation.

AGEs are heterogeneous compounds which adversely affect nearly every type of cell and molecule in the body and lead to human pathological conditions. AGEs are thought to be one of the key factors in skin aging. For example, studies of collagen glycation using skin equivalents²⁹ found a number of changes including modified fibroblast shape and distribution, enhanced extracellular matrix molecules and the dermal-epidermal junction zone, and increased collagenase activity. Additionally, AGE treatment has been found to reduce various biomarkers of skin aging, including those noted above, as well as increased NF-κB activation and cytokine expression.³⁰ Exposure of AGEs to ultraviolet (UV) light generates reactive oxygen species (ROS) in extracellular matrix.³¹

Turning to HR, it has been reported to have an inhibitory effect on the formation of Maillard reaction products (*in vitro* using glucose and cysteine).³² Given the importance of Maillard reactions in the formation of AGEs, it is expected that HR, when applied topically, would provide skin benefits due to its anti-glycation/anti-AGE property.

Melanin and Melanogenesis

Pigmentation

Skin color is one of the most important physical traits of humans because it affects so many aspects of our health and social well-being. Skin color is also one of the best examples of evolution by natural selection acting on the human body. Anthropologic studies have provided us with two important facts: the earliest *Homo sapiens* had dark skin, rich in protective melanin, and small groups of “modern” humans

dispersed out of the African tropics into less intensely sunny parts of Africa, Eurasia, and the Northern Hemisphere. Over time, these latter groups of humans underwent genetic changes leading to the loss of melanin pigmentation.³³ Skin color is one of the most conspicuous ways in which humans vary and has been widely used to define human races. Unfortunately, skin color is also a determinant of human interaction and destinies.

Human skin coloration is both adaptive and labile as evidenced by the multitude of different skin colors of humans around the world. Though humans are often characterized as having black, white, red, or yellow skin, no one is actually any of these colors, as these are commonly used terminologies that do not reflect biological reality.³⁴ Skin coloration in humans arises from a complex series of cellular processes involving the synthesis and transfer of a pigment, melanin, which, besides being responsible for skin color and tone, is the key physiological defense against sun-induced damage, such as sunburn, photo-aging, and photo-carcinogenesis. The melanin itself is formed by a sequence of reactions in which tyrosine is oxidized to dopa and then dopa is subsequently oxidized to melanin. These reactions are catalyzed by the enzyme tyrosinase. The formation of melanin, also known as melanogenesis, is carried out in melanosomes, organelles of that population of cells known as the melanocytes, which are located in the lower part of the epidermis. The melanosomes containing the melanin are subsequently transferred from the melanocytes to the neighboring cells, the keratinocytes, which then transport and distribute the melanin to the upper layers of the skin.³⁵

Skin coloration is primarily regulated by the amount and type of melanin synthesized by the melanocytes^{36,37}; however, additional and equally contributing factors include (a) the efficiency of the transfer of the melanosomes, hence the melanin, from the melanocytes to the neighboring keratinocytes, a process that occurs with the help of E-cadherin, an adhesion protein, and (b) the subsequent distribution and degradation of the transferred melanosomes by the recipient keratinocytes.³⁸ Although a number of factors can influence the formation of melanin, exposure of the skin to UV light markedly influences and increases the amount and rate of melanin production, most often producing a further darkening of the skin or a “tan.” Sun exposure as well as hormones and other environmental and physiological factors can also lead to more localized skin pigmentation, e.g., age spots, melasma, and freckles, owing to an overabundance of melanin production in the afflicted areas of the skin.

Skin Lightening/Even-Toning

For a substantial segment of the human population, one’s natural skin color is not satisfactory and efforts are undertaken to modify it. For example, in North America, Europe, and Australia, many endeavor to enhance skin pigmentation through tanning, whether natural (induced melanin production) or artificial (dyes). Others, especially certain Asian cultures, endeavor to prevent skin coloration and/or seek to actually lighten their natural skin color. Additionally, skin lightening efforts are oftentimes undertaken to address or eliminate age spots, melasma, and freckles, or to obtain even-toning effect with one’s skin.

HR has been found to have a significant skin lightening effect due to a strong inhibitory effect on tyrosinase and peroxidase and a stimulatory effect on glutathione and E-cadherin syntheses. It is believed that the HR bind to tyrosinase directly and inhibits its enzyme activity.³⁹ Additionally, having observed that fragments of DNA can stimulate melanin synthesis, it seems that the reduction of DNA damage by HR, as previously noted, may also be responsible for inhibition of melanin synthesis.

Chen et al. found that HR inhibits both the monophenolase (tyrosine to DOPA) and diphenolase (DOPA to DOPochrome) activity of mushroom tyrosinase.³⁹ Its activity or mode of action, as shown by a kinetic analysis, is as a competitive inhibitor. More recently, Chaudhuri demonstrated that HR is a far superior tyrosinase inhibitor (using both tyrosine and DOPA substrates) than the three commercially available skin lighteners: hydroquinone, kojic acid, and licorice extract.¹² Concurrently, HR was found to provide superior inhibition of peroxidase activity of HR as compared to the three skin lighteners tested as well.¹² This study also showed that at 10 µg/mL use level, HR had inhibitory effects on extracellular and intracellular melanin production by 75% and 36%, respectively, when compared with placebo. Related studies using B16 melanoma cells showed that their growth rate was not significantly altered in the presence of HR during a 72 h incubation period, indicating that the HR-induced regulatory effects on melanogenesis of melanoma cells occurred without affecting cell proliferation.¹²

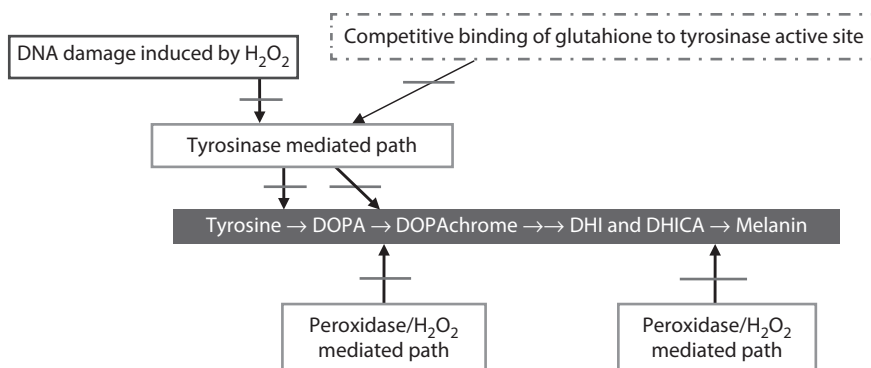

FIGURE 7.2 Sites in the melanogenesis pathway in melanocytes inhibited by HR. DOPA = 3,4-dihydroxyphenylalanine; DOPAchrome = 5,6-dioxo-2,3,5,6-tetrahydro-1H-indole-2-carboxylic acid; DHI = 5,6-dihydroxyindole; DHICA = 5,6-dihydroxyindole-2-carboxylic acid.

Literature data shows that low glutathione levels relates to the deposition of melanin in the skin of humans and other animals, whereas high glutathione levels inhibit melanogenesis.^{40,41} It is also reported that glutathione depletion increases tyrosinase activity in human melanoma cells.⁴² UVA irradiation induces the immediate loss of reduced glutathione (GSH) in both melanocytes and keratinocytes.⁴³ Recently, Matsuki et al. have reported that glutathione has a dose dependent inhibition on melanin synthesis in the reaction of tyrosinase and L-DOPA.⁴⁴ Since HR has a dose dependent increase effect on glutathione synthesis,²⁴ it can be concluded that HR also inhibits melanogenesis by stimulating glutathione synthesis.

It has also been found that human skin exposed to UVB irradiation with a dose of 2 MED manifests a significant increase in the expression of Endothelin-1 (ET-1) and tyrosinase mRNA signals five days after irradiation.^{45,46} In these studies, low levels of ET-1 secreted by keratinocytes in response to UVR was shown to down-regulate E-cadherin in melanocytic cells. ET-1 is a potent down-regulator of E-cadherin in human melanocytes and also melanoma cells.⁴⁶ An independent study by Chaudhuri has shown a 15-fold up-regulation of CDH-1 gene coding for E-cadherin as compared to a control in UVB irradiated normal human keratinocytes treated with HR. In light of the foregoing, it is quite tempting to propose that HR also reduces UV-induced hyperpigmentation by modulating E-cadherin.

Eller et al. have shown that DNA damage after UV irradiation enhances UV-induced melanization.⁴⁷ They have also shown that the addition of small DNA fragments to un-irradiated pigment cells *in vitro* or *in vivo* to guinea pig skin induces a pigment response indistinguishable from UV-induced tanning. Based on the study reported by Yen et al. which found that HR reduces DNA damage induced by hydrogen peroxide²⁴; it is quite conceivable to conclude that HR also inhibits melanin synthesis by reducing DNA damage.

Taken together, the data generated by the present author and available in the literature strongly suggests that HR provides for a reduction in melanin production by modulating multiple sites in the melanogenesis pathway in melanocytes. This pathway and the sites of action of HR (shown by arrows) are portrayed in Figure 7.2.

Human Clinical

In addition to the multitude of *in vitro* and non-human *in vivo* studies on the effects of HR on skin mechanisms and physiology, many of which are discussed above, there are a number of human clinical studies that have been reported. Chaudhuri has reported on the skin-lightening efficacy and safety of a lotion containing 0.5% HR compared with a 2% hydroquinone lotion.¹² This was a single-center study of 15 subjects who applied the lotions twice a day, morning and evening, for eight weeks. The test sites, as well as untreated sites on each forearm, were evaluated for skin color change as represented by the change in

TABLE 7.2

Human Clinical Study: Skin Lightening Effects of HR vs. Hydroquinone

Skin Lightening Active	Week	L-value	% Improvement Based on L-Value	ITA°	% Improvement Based on ITA°
0.5% HR	0	56.88	—	19.09	—
	4	58.82	3.4	24.34	27.5
	8	59.54	4.7	26.26	37.6
2.0% Hydroquinone	0	57.10	—	20.72	—
	4	58.95	3.2	24.67	27.7
	8	59.54	4.3	27.22	38.4

L values and ITA° (Individual Topology Angle—COLIPA SPF test method). Changes were measured by chromometric measurement. The results of this study are presented in Table 7.2 where the delta represents the percent change in skin color from the baseline coloration of the untreated skin. According to these results, the HR lotion was found to provide a comparable, statistically significant (p value ≥ 0.001) change in skin color to that attained with the like composition containing 2% hydroquinone. Such results are consistent with a “lightening” of the skin. No adverse effects were noted for either lotion over the test period.

Another clinical study was carried out by the present author using 1% HR lotion for treating individuals having hyper-pigmented spots. Eighteen volunteers between the ages of 42 and 60, of which there was a mix of Caucasian (10), Asian (7), and Hispanic (1), applied the 1% HR lotion twice daily in an amount sufficient to cover their upper arm, including specifically the targeted hyper-pigmented spots. The treated skin of each volunteer was evaluated and the percent reduction in pigmentation of the treated skin was determined using ITA degree. When compared to the coloration on day zero (pre-application), it was found that the treated hyper-pigmented spots showed a statistically significant reduction of 39% and 60% in pigmentation at four and eight weeks, respectively. On the other hand, the treated area of the skin surrounding the hyper-pigmented spots showed only marginal changes when compared to day zero (pre-application). Based on this study, one could conclude that a 1% HR lotion provides an even-toning effect.

Chaudhuri also investigated the potential for HR to show a synergistic effect when used in combination with other skin lightening ingredients. In this study, a lotion containing 2% by weight of a commercial blend of HR (25%) and ethyl linoleate (EL, 25%) in caprylic/capric triglycerides (trade name Asyntra® SL) was applied twice daily for a period of four weeks to the whole face of 15 volunteers. As in the previous studies, skin color was determined by ITA degrees before and after the treatment. The results of this study demonstrated a statistically significant ($p \leq 0.05$) lightening effect on the natural skin color (initial ITA degree 2.1 vs. 5.8 after four weeks of treatment). The combination was also found to be much more effective than HR alone in lightening one’s natural skin color. The synergy of the ingredients of this blend was subsequently confirmed by carrying out an *in vitro* study using B16 melanoma cells. In that study, referenced in the preceding section, an almost identical level of reduction in melanin synthesis was observed using the HR-EL blend (contains only 25% HR) as compared to the use of HR alone. Although the full mechanism is unknown, it has been reported that EL is hydrolyzed to linoleic acid (LA) *in vivo*,⁴⁸ which has been reported to degrade post-translational tyrosinase and is also involved in the increase in cell turnover.⁴⁹ Therefore, it can be presumed that, in addition to the synergistic effect with HR, EL is also providing all of the skin benefits resulting from its conversion to LA.

Independently, Makino et al. reported on a single-center, double-blind comparison clinical study of 18 subjects in which the efficacy of a HR-containing (included several other skin lightening ingredients) cream for reducing ultraviolet-induced hyperpigmentation was evaluated.⁵⁰ Test sites were irradiated with 1.0, 1.5, 2.0, and 2.5 minimal erythema doses. After five days during which pigmentation was allowed to develop, the HR-containing product or a 4% hydroquinone cream was applied to the respective test sites, once daily for four weeks. Chroma meter measurements (L^* brightness) and standardized

digital photographs were taken of the test sites twice a week. According to their findings, areas treated with the HR-containing product produced greater increases in L* brightness as compared with those treated with the 4% hydroquinone cream. This study demonstrates that a product designed to affect multiple pathways of melanogenesis and melanin distribution may provide an additional treatment option beyond hydroquinone for hyperpigmentation.

In another study, Fantasia et al. reported on a 12-week, double-blind, split-face, randomized clinical study in which an HR-containing lotion was applied to 41 subjects using a round-robin approach against the vehicle, which was applied to 40 subjects, all subjects being women from 35 to 59 years of age.⁵¹ Subjects were selected specifically for overall photo-damage, fine lines, and mottled pigmentation. Each product was applied once daily to the designated half side of the face. Evaluation was done at baseline and after 2, 4, and 12 weeks of treatment using a 1–9 scale for photo-aging parameters. The findings from this study revealed that the HR-containing lotion performed significantly well as compared to the placebo on several key anti-aging clinical parameters, such as tactile roughness, radiance, mottled pigmentation, crow's feet fine lines, and overall photo-damage. Significant clinical benefits were observed as early as two weeks, with progressive improvements at weeks 4 and 12. Such results are consistent with the reports by these authors on the stimulatory effect of HR on collagen and elastin synthesis through NF-kappaB inhibition.

Roure et al. reported on a double-blind, randomized, placebo controlled study on healthy women volunteers aged over 45 years having wrinkles, sagging, spots, and a dull complexion on the face using a HR and ascorbic acid-2-glucoside-containing formulation.²⁸ Forty-two volunteers applied the product and placebo in a split-face mode, twice a day for 12 weeks. Clinical grading and self-assessment of the signs of aging, cutometric, and colorimetric measurements were performed at baseline and after eight and 12 weeks of application. After eight weeks of daily application, a significant improvement of the wrinkles (crow's feet: +17%, under eye: +19%, cheek: +10%), fine lines (crow's feet: +9%, under eye: +13%), brown spots (intensity: +11%, number: 8%), firmness (+26%), and skin texture (complexion: 18%, homogeneity: +26%, softness: 21%, smoothness: 32%) was observed with the product versus baseline as well as placebo. These changes were even greater after 12 weeks of product application.

Finally, in a 12-week, full face, double-blinded, randomized controlled study in Chinese subjects, Johnson & Johnson scientists have shown significant improvement in key pigmentation-related parameters without detecting any product-related adverse events.⁵² Out of the total study population of 65, 32 subjects using the lotion containing HR product and 31 subject using the vehicle (without HR) completed the 12-week study. Two subjects from the vehicle group were discontinued for non-product related reason. Application of HR containing product resulted in significant clinical improvement (statistically significant vs. placebo; $p < 0.05$) on overall skin lightening (% of subjects showing improvement: 88%), appearance of spots on the cheeks (88%), overall contrast between spots and surrounding skin (100%), and overall pigmentation size (97%) with the vehicle at 12 weeks. Changes were determined by dermatologist grading, digital photos and UV images. These authors further demonstrated that de-pigmenting effect of HR is not associated with toxicity in melanocytes and is reversible; confirming Chaudhuri's earlier observation.¹² In contrast, the inhibition of melanin production, as expected, failed to recover in melanocytes treated with hydroquinone. These findings further validate the potency of HR to modulate skin pigmentation, and its safety and tolerance for topical application.

These studies show that HR has a plurality of strong, beneficial effects on skin physiology and conditioning, including, but not limited to skin lightening, even toning of color, and anti-aging effects.

Formulation

Having demonstrated the benefits of HR as a skin treatment, HR also benefits from an ease of use in terms of formulating products, especially skin care and cosmetic products. This is especially so at use levels of 0.5%–1.0% (w/w) of HR in the finished formulation, which have been found to provide effective products.

HR is highly soluble (>20%) in a number of cosmetic and skin care ingredients and carriers including caprylic/capric triglycerides, isosorbide dicaprylate, ethyl linoleate, ethoxydiglycol, and other high

polarity esters; non-ionic solubilizers; glycerol; and a wide range of glycols. PEG-400 was found to be an excellent solubilizer of HR (>50%). Such solubility provides a wide range of options to develop elegant formulations with HR. HR can also be easily combined with other skin lightening ingredients, such as niacinamide, ethyl linoleate, acetyl-glucosamine, ascorbyl-2-glucoside (not magnesium and sodium ascorbyl phosphate as these two requires slightly basic formulation pH), standardized plant extracts, such as *Phyllanthus emblica* (trade named Emblica®), *Terminalia chebula* (trade named Synastol® TC), etc., thereby opening the door to a multitude of synergistic products to make HR even more effective.

Generally, the pH of the formulation to which HR is added must be acidic due to the presence of phenolic OH in HR. Similarly, it is found that the use of non-ionic emulsifiers is preferable to anionic types. For the preparation of serum or transparent gels, the use of non-ionic solubilizers having high HLB values like PEG-40 hydrogenated castor oil, Laureth 23, Polysorbate 20, and Polysorbate 80 are recommended.

Finally, the addition of HR to various formulations may cause a drop in overall viscosity of the product. In such cases, anionic (such as Xanthan gum, Carbomers) or neutral thickeners (such as Cellulosics) can be added for maintaining and/or restoring the desired viscosity. If needed, low levels 0.1%–0.2% of propyl gallate (Synoxyl® PGL) can be used to minimize color shift over time.

Conclusion

Although the present author endeavored to identify all relevant articles and dates, it is nonetheless acknowledged that some will have been overlooked, for which the author apologizes. Nevertheless, this chapter provides ample evidence of the complex physiological actions of HR and its ability to modulate different biological processes and pathways through multiple molecular targets. Key targets include those associated with skin pigmentation, inflammation and inflammatory responses, extracellular matrix proteins, and the like. Such activity clearly points to the realized and yet to be realized significance of HR in providing a number of skin benefits of commercial interest. Already, commercial use of HR in a wide variety of skin care and treatment products has begun and is expanding. Additionally, further work exploring and fleshing out the impact of HR on tumors will likely lead to the establishment of HR as a key ingredient in combination therapy. In summary, it is clear from the current literature that HR has numerous targets, and provides its biological effects through simultaneous modulation of these targets.

REFERENCES

1. Frankos VH, Schmitt DF, Haws LC et al. Generally Recognized as Safe (GRAS) evaluation of 4-hexylresorcinol for use as a processing aid for prevention of melanosis in shrimp. *Regul Toxicol Pharmacol* 1991;14:202–12.
2. Monsalve-Gonzalez A, Barbosa-Canovas GV, McEvily AJ et al. Inhibition of enzymatic browning in apple products by 4-hexylresorcinol. *Food Technol* 1991;49(4):110–8.
3. Arias E, Gonzalez J, Oria R et al. Ascorbic acid and 4-hexylresorcinol effects on pear PPO and PPO catalyzed Browning reaction. *J Food Sci* 2007;72(8):C422–9.
4. Luo Y, Barbosa-Cánovas GV. Preservation of apple slices using ascorbic acid and 4-hexylresorcinol. *Food Sci Technol Int* 1996;2(5):315–21.
5. Guerrero-Beltrán JA, Swanson BG, Barbosa-Cánovas GV. Inhibition of polyphenoloxidase in mango puree with 4-hexylresorcinol, cysteine and ascorbic acid. *Food Sci Technol* 2005;38(6):625–30.
6. Dong X, Wrolstad RE, Sugar D. Extending shelf-life of fresh cut pears. *J Food Sci* 2000;65(1):181–6.
7. Buta JG, Moline HE, Spaulding DW et al. Extending storage-life of fresh-cut apples using natural products and their derivatives. *J Agric Food Chem* 1999;47:1–6.
8. Chhabra RS, Huff JE, Haseman J et al. Inhibition of some spontaneous tumors by 4-hexylresorcinol in F344/N rate and B6C3F1 mice. *Fundam Appl Toxicol* 1988;11:685–90.
9. Buchholz V, Leuwer M, Ahrens J et al. Topical antiseptics for the treatment of sore throat block voltage-gated neuronal sodium channels in a local anesthetic-like manner. *Naunyn Schmiedebergs Arch Pharmacol* 2009;380(2):161–8.

10. Ross AB, Kamal-Eldin A, Aman PD. Alkylresorcinols: Absorption, bioactivities, and possible use as biomarkers of whole-grain. Wheat- and rye-rich foods. *Nutr Rev* 2004;62(3):81–95, and references cited therein.
11. Kozubek A, Tyman JHP. Resorcinolic lipids, the natural nonisoprenoid phenolic amphiphiles and their biological activity. *Chem Rev* 1999;99:1–25.
12. Chaudhuri RK. Effective skin lightening with protective property. *Personal Care* 2010;39–44.
13. Fed. Reg. 1991;56(140):33644.
14. Taylor JA, Mitchenall LA, Rejzek M et al. Application of a novel microtitre plate assay for the discovery of new inhibitors of DNA gyrase and DNA topoisomerase VI. *PLoS One* 2013;8(2):e58010.
15. Payne DJ, Gwynn MN, Holmes DJ et al. Drugs for bad bugs: Confronting the challenges of antibacterial discovery. *Nat Rev Drug Discov* 2007;6:29–40.
16. Wong CF, Barnes LM, Dahler AL et al. E2F suppression and Sp1 over expression are sufficient to induce the differentiation-specific marker, transglutaminase type 1, in a squamous cell carcinoma cell line. *Oncogene* 2005;24:3525–34.
17. Kim SG, Kim AS, Jeong JH et al. 4-Hexylresorcinol stimulates the differentiation of SCC-9 cells through the suppression of E2F2, E2F3 and Sp3 expression and the promotion of Sp1 expression. *Oncol Rep* 2012;28:677–81.
18. Kim SG, Choi JY. 4-Hexylresorcinol exerts antitumor effects via suppression of calcium oscillation and its antitumor effects are inhibited by calcium channel blockers. *Oncol Rep* 2013;29(5):1835–40.
19. Mangala LS, Fok JY, Zorrilla-Calancha IR et al. Tissue transglutaminase expression promotes cell attachment, invasion and survival in breast cancer cells. *Oncogene* 2006;26:2459–70.
20. Fok JY, Ekmekcioglu S, Mehta K. Implications of tissue transglutaminase expression in malignant melanoma. *Mol Cancer Ther* 2006;5:1493–503.
21. Yuan L, Siegel M, Choi K et al. Transglutaminase 2 inhibitor, KCC009, disrupts fibronectin assembly in the extracellular matrix and sensitizes orthotopic glioblastomas to chemotherapy. *Oncogene* 2006;26:2563–73.
22. Lee SW, Kim SG, Park YW et al. Cisplatin and 4-hexylresorcinol synergise to decrease metastasis and increase survival rate in an oral mucosal melanoma xenograft model: A preliminary study. *Tumour Biol* 2013;34(3):1595–603.
23. Kamal-Eldin A, Pouru A, Eliasson C et al. Alkylresorcinols as antioxidants: Hydrogen donation and peroxy radical-scavenging effects. *J Sci Food Agric* 2000;81:353–6.
24. Yen GC, Duh PD, Lin CW. Effects of resveratrol and 4-hexylresorcinol on hydrogen peroxide-induced oxidative DNA damage in human lymphocytes. *Free Rad Res.* 2003;37(5):509–14.
25. Lawrence T. The nuclear factor NF- κ B pathway in inflammation. *Cold Spring Harb Perspect Biol* 2009;1:a001651.
26. Li X, Stark GR. NF- κ B-dependent signaling pathways. *Exp Hematol* 2002;30(4):285–96.
27. Kim SG, Lee SW, Park YW et al. 4-Hexylresorcinol inhibits NF- κ B phosphorylation and has a synergistic effect with cisplatin in KB cells. *Oncol Rep* 2011;26(6):1527–32.
28. Roure R, Bertin C, Perron-Eymery S et al. A double-blind, placebo controlled study revealing the anti-aging efficacy of a hexylresorcinol and ascorbic acid-2-glucoside containing product. *J Am Acad Dermatol* 2011;64(2):AB22 S1.
29. Pigeon H, Asselineau D. An *in vitro* approach to the chronological aging of skin by glycation of the collagen: The biological effect of glycation on the reconstructed skin model. *Ann NY Acad Sci* 2005;1043:529–32.
30. Neumann A, Schinzel R, Palm D. High molecular weight hyaluronic acid inhibits advanced glycation end product-induced NF- κ B activation and cytokine expression. *FEBS Letter* 1999;453(3):283–7.
31. Pigeon H. Reaction of glycation and human skin: The effects on the skin and its components, reconstructed skin as a model. *Pathol Biol* 2010;58(3):226–31.
32. Cheriot SC, Billaud C, Nicolas J. Use of experimental design methodology to prepare Maillard reaction products from glucose and cysteine inhibitors of polyphenol oxidase from eggplant (*Solanum melongena*). *J Agric Food Chem* 2006;54(14):5120–6.
33. Jablonski NG, Chaplin G. Evolution of skin coloration. *J Hum Evol* 2000;39:57–106.
34. Chaudhuri RK. Unrealistic claims—It’s time to get real and get safe about skin lightening. *Soaps Perfumery Cosmetics* 2005:16–7.

35. Yamaguchi Y, Brenner M, Hearing VJ. The regulation of skin pigmentation. *J Biol Chem* 2007;282:27557–61.
36. Ito SA. Chemist's view of melanogenesis. *Pigment Cell Res* 2003;16:230–6.
37. Kasraee B. Peroxidase-mediated mechanisms are involved in the melanocytotoxic and melanogenesis-inhibiting effects of chemical agents. *Dermatol* 2002;205:329–39.
38. Hearing VJ. Regulating melanosome transfer: Who's driving the bus. *Pig Cell Res* 2007;20:334–5.
39. Chen QX, Ke LN, Song KK et al. Inhibitory effects of hexylresorcinol and dodecylresorcinol on mushroom (*Agaricus bisporus*) tyrosinase. *Protein J* 2004;23(2):135–41.
40. Benedetto JP, Ortone JP, Voulout C. Role of thiol compounds in mammalian melanin pigmentation. Reduced and oxidized glutathione. *J Invest Dermatol* 1981;77:402–5.
41. Galvan I, Alonso-Alvarez C. An intracellular antioxidant determines the expression of a melanin-based signal in a bird. *PLoS One* 2008;3(10):e3335.
42. Del Mamol V, Solano F, Sels A et al. Glutathione depletion increases tyrosinase activity in human cells. *J Invest Dermatol* 1993;101:871–4.
43. Larsson P, Andersson E, Johansson U et al. Ultraviolet A and B affect human melanocytes and keratinocytes differently. A study of oxidative alterations and apoptosis. *Exp Dermatol* 2005;14(2):117–23.
44. Matsuki M, Watanabe T, Ogasawara A et al. Inhibitory mechanism of melanin synthesis by glutathione. *Yakugaku Zasshi* 2008;128(8):1203–7.
45. Imokawa G, Kobayashi T, Miyagishi M et al. The role of endothelin-1 in epidermal hyperpigmentation and signaling mechanisms of mitogenesis and melanogenesis. *Pigment Cell Res* 1997;10(4):218–28.
46. Jamal S, Schneider RJ. UV-induction of keratinocyte endothelin-1 downregulates E-cadherin in melanocytes and melanoma cells. *J Clin Invest* 2002;110:443–52.
47. Eller MS, Ostrom K, Gilchrist BA. DNA damage enhances melanogenesis. *Proc Natl Acad Sci USA* 1996;93:1087–92.
48. Hungund BL, Zheng Z, Barkai AI. Turnover of ethyl-linoleate in rat plasma and its distribution in various organs. *Alcohol Clin Exp Res* 1995;19(2):374–7.
49. Ando H, Wen ZM, Kim HY. Intracellular composition of fatty acid affects the processing and function of tyrosinase through the ubiquitin–proteasome pathway. *Biochem J* 2006;394:43–50.
50. Makino ET, Mehta RC, Banga A et al. Evaluation of a hydroquinone-free skin brightening product using *in vitro* inhibition of melanogenesis and clinical reduction of ultraviolet-induced hyperpigmentation. *J Drugs Dermatol* 2013;12(3):s16–20.
51. Fantasia J, Tucker-Samaras S, Saclier S. A synthetic NF-kappaB inhibitor has significant anti-aging benefits on photodamaged facial skin. *J Am Acad Dermatol* 2011;64(2):AB22,S1.
52. Won YK, Loy CH, Randhwa M et al. Clinical efficacy and safety of 4-hexyl-1,3-phenylenediol for improving skin hyperpigmentation. *Arch Dermatol Res* 2014;306:455–65.

8

Hydroxyacids

Claudine Piérard-Franchimont, Didier Saint-Léger, Sarah Peters, and Gerald E. Piérard

Introduction

According to their chemical structure, hydroxyacids correspond to organic carboxylic acids characterized as the α - and β -types (AHA and BHA) according to the position of the hydroxyl group (OH) with regard to the acid (COOH) moiety. Globally, both categories exhibit almost similar biologic effects. These compounds are available worldwide, and likely have been for centuries, as dermatologic and cosmetic ingredients. Their acceptance by dermatologists, other physicians, cosmetologists, and consumers contrasts with the limited independent, well-controlled studies demonstrating their mechanisms of action and their long-term beneficial effects.

Health care and cosmetic regulations differ among continents and countries although skin biology is similar worldwide. Many physicians consider that some respective legal definitions of drugs and cosmetics are outdated and unworkable. It seems obvious that many environmental threats and topical products may produce some biologic effect on the skin. Hence, a series of cosmetics should be viewed as skin physiology modulators. Should they all be classified as real bioactive agents or remedial cosmetics? This is a matter of definition because bioactivity differs by several degrees of magnitude among product categories. In cosmetology, there is a huge difference between decorative formulations, suppletive compounds, and active physiology modulators.¹ Many cosmetic products (makeup, hair styling, hygiene) do not require any biologic action despite being very efficient in terms of achievement of aesthetic needs. Sunscreens, for example, fit within such consideration: they do not interfere, *per se*, with skin physiology, although remain highly efficient in screening much harmful ultraviolet (UV) radiation from the skin. The very words “activity” (to induce an action) and “efficacy” (to induce an effect) have to be well differentiated.²

There is vivid controversy about the concept of cosmeceuticals, designing compounds that fall between cosmetics and pharmaceuticals. This concept received immediate acceptance by some people. However, many corporate leaders contend that cosmeceuticals are neither scientifically sensible nor juridically necessary. In fact, with the exception of cosmeceuticals in the United States and “quasi-drugs” in Japan, national regulatory agencies have not positively recognized the cosmeceutical class. The lack of a clear-cut of clarification risks having negative effects. Some products could be potentially forbidden although they are valuable in cosmetology. The opposite is also true, because some products are used in cosmetology without adequate evaluation of their potential biologic effects. One example is provided by the widespread use of AHAs and BHAs. Despite their obvious anti-xerotic and their peeling effects at given concentrations, there is little information available about their general toxicity and ancillary biologic effects. However, one should bear in mind the potential toxic effects of hydroxyacids. One example is given by O-hydroxybenzoic acid (salicylic acid) in the case of high percutaneous absorption, particularly in children.

Chemical Structure and Natural Sources of AHAs

AHAs range from simple aliphatic compounds to complex molecules. Many of these compounds were originally derived from natural sources, and thus are commonly referred to as fruit acids. However, a

TABLE 8.1
Hydroxyacid Classification

<i>α-Hydroxyacids</i>
Monocarboxylic acids:
Glycolic acid
Lactic acid
Mandelic acid
Dicarboxylic acids:
Malic acid
Tartaric acid
Tricarboxylic acid:
Citric acid
<i>β-Hydroxyacids</i>
Salicylic acid (ortho hydroxybenzoic acid)
Lipohydroxyacid (2-hydroxy-5-octanoyl benzoic acid)
Tropic acid

number of synthetic sources provide access to structural analogs. Most AHAs used in dermatology and cosmetology are currently produced by chemical synthesis. They are characterized in chemical groups based on the number of carboxylic groups (Table 8.1). According to their configuration, AHAs are present under different stereoisomeric structures called enantiomers “l” and “d” or “R” and “S.” Some of the common AHAs occur naturally in an enantiomerically enriched form, and both enantiomers may be available.

Glycolic acid (2-hydroxyethanoic acid) is a component of sugar cane juice. Lactic acid (2-hydroxypropanoic acid) was first isolated in 1780. The l-lactic acid produced by the microorganism *Lactobacillus* is responsible for the taste and odor of sour milk. It is, in addition, an end product of the anaerobic metabolism of the epidermis, present onto the skin surface and in eccrine sweat at low concentration. The other enantiomer d-lactic acid, also called sarcolactic acid, is formed during anaerobic muscular contraction, and is also found in apples, ergot, digitale, opium, and tomatoes. Mandelic acid (2-hydroxy-2-phenylethanoic acid) is obtained from hydrolysis of bitter almond extracts. Malic acid (2-hydroxy-1,4-butanedioic acid) was first isolated from unripened apples in 1785. Tartaric acid (2,3-hydroxy-1,4-butanedioic acid) was first isolated in 1769. It is widely distributed in plants, particularly in grapes and the lees of wine. Citric acid (2-hydroxy-1,2,3-propanetricarboxylic acid) was first isolated from lemon juice in 1784. It is also found in pineapples and other citrus fruits.

Biologic Activities of Hydroxyacids

A number of biologic aspects of the hydroxyacid action remain unsettled because hasty conclusions were offered from uncontrolled studies. Hence, a wealth of hydroxyacid-enriched cosmetics are present on the market with unsubstantiated claims or little evidence of performance. In some instances, erroneous information and incorrect statements have flourished behind promotional objectives.

At least one facet of the hydroxyacid biologic activities is ascribed to the native acid strength of the compounds. This physicochemical characteristic is measured by the proton dissociation in solution, and is expressed by its pKa. The lower the pKa of a hydroxyacid, the stronger its acidic strength: a decrease of 1 pKa unit represents a tenfold increase in the acid strength. If the acid strength influences some of the biologic effects of hydroxyacids, it does not, however, correlate with the overall potency of the final topical formulation.

The pH of the formulations varies with both the nature of the hydroxyacid and its concentration. In order to avoid irritation as much as possible, it is desirable to design a cosmetic formulation with a pH close to the physiologic pH range of the skin.^{3,4} This may be achieved by partial neutralization and by adding an effective buffer. However, AHA products at neutral pH seem to exert little effect on skin.

In order to prevent misunderstandings and misstatements, the biologic activities of hydroxyacids should be evaluated with regard to their chemical structure irrespective of their acidity. Such information is not fully rooted in scientific data. The exquisite enantioselectivity exhibited by many biologic systems suggests that enantiopurity is an important parameter in any pharmacological effect including pharmacokinetics, metabolic rate, and toxicity. Thus, the racemic components likely interact differentially with biomolecules of the skin. Whether such a concern is of importance for the effects elicited by hydroxyacids is not settled.

The clinical indications of hydroxyacids are multiple.⁵ Both AHAs and BHAs exert undisputable direct effects on the stratum corneum (SC), at least in the presence of xerosis, ichthyosis, and analogous conditions. Some hyperpigmentation disorders benefit from the same compounds. Comedonal hyperkeratosis in acne-prone subjects is commonly improved. In the field of benign tumors, keratoses and viral warts are effectively treated by high concentration formulations. Such treatment is largely related to the pH-related chemical burn. Similar caustic effects are also induced in order to perform skin peelings. The effect of hydroxyacids on actinodermatosis appears more complex, involving multifaceted mechanisms, boosting some of the deficient physiologic aspects of aging skin.

Most of the aforementioned effects are in part hydroxyacid dose-dependent. In this chapter, the category low concentration is arbitrarily defined when there is less than 4% of active compound in the formulation. Medium concentration applies to the range 4%–12%, and high concentration for upper dosages. From a regulatory viewpoint, the U.S. Food and Drug Administration (FDA) considers hydroxyacids as cosmetic ingredients provided a maximum 10% concentration, formulated above pH 3.5. Above this concentration and/or below this pH, they fall under the drug categorization.

Effects on Corneocyte Cohesion and Stratum Corneum Functions

During the formation and maturation of the stratum corneum (SC), the intercellular binding by desmosomes becomes modified into corneodesmosomes. Their numbers usually decrease towards the surface of the skin, most notably during the stratum compactum to stratum disjunctum transition.⁶ In xerotic, scaly, and ichthyotic conditions, ordered desquamation is impaired because desmosomes persist up to the outer SC leading to the unruly accumulation of corneocytes and to skin scaling and flaking.^{6,7} Environmental conditions often influence these skin conditions.⁷

Salicylic acid is the time-honored BHA used in dermatology to improve xerotic and scaly conditions. Although this compound at low and medium concentrations exhibit little or no effect on the normal SC, there is evidence that complete corneodesmosome degradation is helped in various xerotic and ichthyotic disorders.⁸ It therefore appears that the term keratolytic applied to such a compound is a misnomer, while a desmolytic agent would be more appropriate and explicit.⁶ The clinical effects of hydroxyacids on such hyperkeratotic conditions is conveniently assessed using a series of biometrological methods.^{7–10}

A lipophilic derivative of salicylic acid was designed some years ago.¹¹ It corresponds to the 2-hydroxy 5-octanoyl benzoic acid, also named lipohydroxyacid (LHA). One of the main targets is clearly the corneodesmosomes which appear to be weakened following altered chemical bonds in the junctional complexes.^{11–13} Subtle differences in desmolytic activity of salicylic acid and LHA were ascribed to the respective hydrophilic and lipophilic natures of these compounds.¹⁰ LHA is likely to have a potential clinical advantage, as it appears to only interact with the more superficial layers of the SC. In addition, its activity is more closely targeted than that of salicylic acid, because it is channeled into the junction between the corneodesmosome and the corneocyte envelope.¹³ By contrast, salicylic acid degrades corneodesmosomes rather indiscriminately.¹³

Various AHAs, particularly lactic acid and glycolic acid in the medium range of concentrations, have profound inhibitory effects on corneocyte cohesion.^{14–16} The usefulness of such formulations in xerotic and allied conditions is beyond doubt.^{16–19} The precise mechanisms of AHA action are poorly documented. A desirable pH for inducing desquamation with AHA application apparently lies between 2.8 and 4.8. The pH changes at the skin surface persist several hours following applications and affect a number of SC layers according to the AHA concentration.³ A discrete superficial lytic effect in corneodesmosomes

occurs in response to low dosages. In other circumstances, when an appropriate amount of a given AHA is topically applied, the SC abruptly becomes detached at its lowermost levels within a couple of days, and desquamation occurs as large flakes or sheets. In such instances, no disaggregation of corneocytes is apparent at the upper SC levels. These changes result in skin peeling.¹⁶ To explain this event, speculation has been made on the interaction between AHAs and various enzymatic processes involved in the maturation and disaggregation of the SC.

In addition to the therapeutic effect of the various hydroxyacids improving hyperkeratotic disorders, the same products yield cosmetic benefits by increasing plasticization and flexibility of the SC without impairing the barrier function.^{11,20} This barrier function was even reported to be improved by some AHAs, leading to increased resistance to SLS-induced skin irritation. The latter beneficial effect was not equal for all hydroxyacids, being more marked for AHAs characterized by antioxidant properties. A similar protection was not provided by applications of salicylic acid.²¹

Peeling and Caustic Effects

When applied to the skin at high concentrations, AHAs may cause necrosis and detachment of keratinocytes corresponding to exogenous epidermolysis.²² Such an injury results in a chemical peel¹⁹ depending primarily on the disruption of the skin pH. The farther away from the physiological pH, the greater the caustic effect, the greater the risk of adverse events, but the more likely the patient receives the resurfacing benefits of the peeling agents. A tolerable sense of burning and itching is often experienced by the patients.

The indications of such treatment modality encompass the destruction of slightly elevated seborrheic and actinic keratoses.²² The full-strength preparation must be applied carefully and exactly to the target lesions in an office procedure. After a few minutes, the entire lesion is curetted off. Viral warts are similarly eradicated by hydroxyacids in a home-administered treatment, with applications made daily for several days. To shorten the treatment period, the outer portion of the hyperkeratosis should be removed with a scalpel in an office setting.

Hypopigmenting Effect

Glycolic acid peels are a useful adjunctive treatment of epidermal hypermelanosis such as in melasma and acne scars.^{23,24} The association of 10% glycolic acid and 2% hydroquinone improves this disorder.^{24–26} Still another therapy combines 5% glycolic acid and 2% kojic acid.²⁵ It is thought that AHAs act like penetration enhancers and accelerate the epidermal turnover.

Acne and Pseudofolliculitis Treatment

Salicylic acid is listed among active products to treat acne.²⁶ However, clearcut evidence for a significant benefit at low concentration in well-controlled experimental and clinical trials is scant. Similarly, medium concentrations of AHAs such as glycolic acid, lactic acid, and mandelic acid are employed twice daily to improve mild acne.^{24,27} It has been postulated that hydroxyacids promote dislodgement of comedones and prevent their formation as well. Many of these treatments await validation by independent controlled studies. In our experience, the lower AHA concentrations as present in some cosmetic products exhibit little or no effect whatsoever on acne and comedones.

Another modality of acne treatment consists of using high concentrations of glycolic acid in an office setting.⁴ The procedure has to be repeated weekly or so. In addition to the comedolytic effect, the higher hydroxyacid concentrations help to unroof pustules and affect the follicular epithelium. The skin condition improvement is reported to be precipitous while patients were taking oral tetracyclines. Discomfort, mild diffuse erythema, and fine scaling are often experienced by patients. In addition, there is a risk for stronger irritation leading to a papular and perifollicular erythema that commonly persists for a few weeks.

A 2% LHA formulation was shown to exert a comedolytic effect in acne-prone subjects.^{22–30} The lipophilic properties of LHA allow maximum concentration inside the SC, particularly in the sebum-enriched infundibulum of the pilosebaceous units. Thus, the compound is likely to be trapped in lesional sebaceous follicles which represent a critical therapeutic target in comedonal acne. The product has shown efficacy in preventing post-summer comedonal acne and in treating mild acne.^{28,31} LHA has the capacity to decrease both the number and the size of the cornified follicular plugs induced by intense ultraviolet (UV) light exposure.³¹ The combination of the LHA formulation with a retinoic acid cream every other evening results in the overall decrease in the functional and physical intolerance reactions.²⁹

Pseudofolliculitis is another related disorder that can be improved by topical AHA treatment. Rosacea might similarly benefit from the combination of an evening AHA cream and a sun-protective daytime preparation.⁴

Boosting Skin Physiology

One fascinating aspect in the effects of hydroxyacids is the boosted physiology that was claimed to occur in the epidermis and dermis.^{31,32} Accordingly, some of these compounds are used to correct skin atrophy and to induce a gradual reduction in the aging signs including pigmentary changes³³ and wrinkles of fine and moderate depths.^{32,34–36} However, only a few controlled clinical trials and experimental studies have been conducted to validate these observations.

After a few days of application of 12% glycolic acid at low pH, fine wrinkles of the face may vanish as a result of the irritation and dermal edema. Besides the untoward immediate effect of stinging, such smoothing effect is rapidly alleviated upon arrest of the topical treatment. Furthermore, in long-term applications, there is some concern regarding the occurrence of chronic low-grade inflammation producing reactive oxygen species (ROS) damaging cells as well as collagen and elastic fibers. However, signs of repair and reverse changes of aging and photoaging were reported on long-term therapy. Such findings were not confirmed in other studies, which rather indicated an almost absence of AHA effects on major skin aging features.^{34–36} In fact, deposits of glycosaminoglycans in the dermis result from inflammation which has been mistakenly interpreted as a correction of aging. A comparative controlled study showed that tretinoin was more active than medium concentrations of glycolic acid in the improvement of the facial skin tensile properties.³⁴ It should be noted that the combination of tretinoin and AHAs may be beneficial in improving the aspect of photoaged skin.³⁶

In contrast with salicylic acid, low concentrations of LHA elicit a dermo-epidermal stimulation^{12,36–39} leading to increased keratinocyte proliferation and epidermal thickness. Such effects are more evident in older skin and remain within the physiologic range of normal skin. At the difference with other AHAs and BHAs, angiogenesis is moderately increased by LHA. An increased number of Factor XIIIa-positive dermal dendrocytes occurs after topical applications of AHAs and LHA.³⁹ These cells may influence the metabolism of fibroblasts and endothelial cells. The increase in Factor-XIIIa expression may somehow relate increased vascularity and dermal improvements following LHA and tretinoin treatments in photoaged patients.³⁹

Safety

Adverse reactions following LHA applications are mostly represented by stinging sensations without any other clinical and histopathological signs of irritation. However, the higher concentrations are responsible for severe redness, swelling (especially in the area of the eyes), burning, blistering, bleeding, rash, itching, and skin discoloration. Their long-term effects are unknown. It has been claimed that BHAs are effective as exfoliants without the occasional irritation associated with the use of AHAs.

Some AHA users suffer from greater reactivity to sun exposure. Indeed, it was reported that subjects who receive AHA products in the presence of UV radiation experience twice the cell damage in areas where the AHA is applied than controls.

The U.S. FDA stated that AHAs were readily absorbed into the skin at varying rates. The most rapid absorption occurred with AHAs at lower pH.⁴⁰ The safety of salicylic acid used as a cosmetic ingredient was evaluated by the U.S. FDA and the Cosmetic Ingredient Review (CIR). They concluded that products containing salicylic acid should contain a sunscreen or bear directions advising consumers to use other sun protection.⁴¹

Conclusions

AHAs and BHAs enjoy tremendous interest in dermatology and cosmetology. These compounds under the presentation of peels and home regimens are recognized as important preventive means and adjunctive therapy in a variety of skin conditions. Thus, they attract media attention and consumer curiosity. Claims and proven effects are contradictory by some aspects. LHA had appeared effective in the treatment of signs of skin aging and in acne treatment without the occasional irritation associated with the use of AHAs.

Much remains to be learned, and speculations must be turned to facts. Improved regimens capitalizing on the various beneficial effects of hydroxyacids should be explored. Synergistic effects can be expected with some other compounds. Considering the safety status, consumers who use AHA and BHA products should follow some precautions about ultraviolet radiation exposure.

REFERENCES

1. Piérard GE, Piérard-Franchimont C, Xhaufilaire-Uhoda E, Quatresooz P. Remedial cosmetics at the cross-roads between cosmetology and dermatology. *Household Pers Care* 2007;3:54–5.
2. Saint-Leger D. “Cosmeceuticals”. Of men, science and laws... *Int J Cosmet Sci* 2012;34:396–401.
3. Rippke F, Schreiner V, Schwanitz HJ. The acidic milieu of the horny layer. New findings on the physiology and pathophysiology of skin pH. *Am J Clin Dermatol* 2002;3:261–72.
4. Parra JL, Paye M, the EEMCO Group. EEMCO guidance for the *in vivo* assessment of skin surface pH. *Skin Pharmacol Appl Skin Physiol* 2003;16:188–202.
5. Tung RC, Bergfeld WF, Vidinos AT, Renzi BK. α -Hydroxy acid-based cosmetic procedures. Guidelines for patient management. *Am J Clin Dermatol* 2000;1:81–8.
6. Piérard GE, Goffin V, Hermanns-Lê T, Piérard-Franchimont C. Corneocyte desquamation. *Int J Mol Med* 2000;6:217–21.
7. Piérard-Franchimont C, Piérard GE. Beyond a glimpse at seasonal dry skin. A review. *Exog Dermatol* 2002;1:3–6.
8. Piérard GE, Masson P, Rodrigues L et al. EEMCO guidance for the assessment of dry skin (xerosis) and ichthyosis: Evaluation by stratum corneum strippings. *Skin Res Technol* 1996;2:3–11.
9. Piérard-Franchimont C, Henry F, Piérard GE. The SACD method and the XLRs squamometry tests revisited. *Int J Cosmet Sci* 2000;22:437–46.
10. Piérard-Franchimont C, Petit L, Piérard GE. Skin surface patterns of xerotic legs: The flexural and accretive types. *Int J Cosmet Sci* 2001;23:121–6.
11. Lévêque JL, Corcuff P, Gonnord G et al. Mechanism of action of a lipophilic derivative of salicylic acid on normal skin. *Skin Res Technol* 1995;1:115–22.
12. Lévêque JL, Corcuff P, Rougier A, Piérard GE. Mechanism of action of lipophilic acid derivative on normal skin. *Eur J Dermatol* 2002;12:S35–8.
13. Corcuff P, Fiat F, Minondo AM, Lévêque JL, Rougier A. A comparative ultrastructural study of hydroxyacids induced desquamation. *Eur J Dermatol* 2002;12:S39–43.
14. Yener G, Baitokova A. Development of a w/o/w emulsion for chemical peeling applications containing glycolic acid. *J Cosmet Sci* 2006;57:487–94.
15. An S, Lee E, Kim S et al. Comparison and correlation between stinging responses to lactic acid and bioengineering parameters. *Contact Dermatitis* 2007;57:158–62.
16. Xhaufilaire-Uhoda E, Piérard-Franchimont C, Piérard GE. Effects of various concentrations of glycolic acid at the corneoxenometry and collaxenometry bioassays. *J Cosmet Dermatol* 2008;7:194–8.
17. Redaelli A. Cosmetic use of polylactic acid for hand rejuvenation: Report on 27 patients. *J Cosmet Dermatol* 2006;5:233–8.

18. Oresajo C, Yatskayer M, Hansenne I. Clinical tolerance and efficacy of capryloyl salicylic acid peel compared to a glycolic acid peel in subjects with fine lines/wrinkles and hyperpigmented skin. *J Cosmet Dermatol* 2008;7:259–62.
19. Thiéry G, Coulet O, Adam S, Guyot L. Poly-L-lactic-acid filling on facial lipoatrophy in HIV+ patients under tritherapy. *Rev Stomatol Chir Maxillofac* 2008;109:103–5.
20. Effendy I, Kawangsuksith C, Lee JY, Maibach HI. Functional changes in human stratum corneum induced by topical glycolic acid: Comparison with all-trans retinoic acid. *Acta Dermatol Venereol* 1995;75:455–8.
21. Piérard-Franchimont C, Goffin V, Piérard GE. Modulation of stratum corneum properties by salicylic acid and all-trans-retinoic acid. *Skin Pharmacol Appl Physiol* 1998;11:266–72.
22. Marrero GM, Katz BE. The new fluor-hydroxy pulse peel. *Dermatol Surg* 1998;24:973–8.
23. Sharquie KE, Al-Tikreety MM, Al-Mashhadani SA. Lactic acid chemical peels as a new therapeutic modality in melasma in comparison to Jessner's solution chemical peels. *Dermatol Surg* 2006;32:1429–36.
24. Garg VK, Sinha S, Sarkar R. Glycolic acid peels versus salicylic-mandelic acid peels in active acne vulgaris and post-acne scarring and hyperpigmentation: A comparative study. *Dermatol Surg* 2009;35:59–65.
25. Petit L, Piérard GE. Skin-lightening products revisited. *Int J Cosmet Sci* 2003;25:169–81.
26. Eady EA, Burke BM, Pulling K, Cunliffe WJ. The benefit of 2% salicylic acid lotion in acne—A placebo-controlled study. *J Dermatol Treat* 1996;7:93–6.
27. Wang CM, Huang CL, Hu CTS et al. The effect of glycolic acid on the treatment of acne in Asian skin. *Dermatol Surg* 1997;23:23–9.
28. Piérard GE, Rougier A. Nudging acne by topical beta-lipohydroxy acid (LHA), a new comedolytic agent. *Eur J Dermatol* 2002;12:S47–8.
29. Rougier A, Richard A. Efficacy and safety of a new salicylic acid derivative as a complement of vitamin A acid in acne treatment. *Eur J Dermatol* 2002;12:S49–50.
30. Uhoda E, Piérard-Franchimont C, Piérard GE. Comedolysis by a lipohydroxyacid formulation in acne-prone subjects. *Eur J Dermatol* 2003;13:65–8.
31. Kim SJ, Park JH, Kim DH et al. Increased *in vivo* collagen synthesis and *in vitro* cell collagen synthesis and *in vitro* cell proliferative effect of glycolic acid. *Dermatol Surg* 1998;24:1054–8.
32. Henry F, Claessens N, Martalo O, Friature AL, Piérard-Franchimont C, Piérard GE. Towards obsolete senescence. Everything wanes... old age no longer exists! *Rev Med Liège* 2000;55:110–3.
33. Kim YJ. Antimelanogenic and antioxidant properties of gallic acid. *Biol Pharm Bull* 2007;30:1052–5.
34. Piérard GE, Henry F, Piérard-Franchimont C. Comparative effect of short-term topical tretinoin and glycolic acid on mechanical properties of photodamaged facial skin in HRT-treated menopausal women. *Maturitas* 1996;23:273–7.
35. Stiller MJ, Bartolone J, Stern R et al. Topical 8% glycolic acid and 8% L-lactic acid creams for the treatment of photodamaged skin. *Arch Dermatol* 1996;132:631–6.
36. Piérard GE, Uhoda I, Piérard-Franchimont C. From skin microrelief to wrinkles. An area ripe for investigation. *J Cosmet Dermatol* 2003;2:21–8.
37. Piérard GE, Nikkels-Tassoudji N, Arrese JE, Piérard-Franchimont C, Lévêque JL. Dermo-epidermal stimulation elicited by a β -lipohydroxyacid: A comparison with salicylic acid and all-trans-retinoic acid. *Dermatology* 1997;194:398–401.
38. Avila Camacho M, Montastier C, Piérard GE. Histometric assessment of the age-related skin response to 2-hydroxy-5-octanoyl benzoic acid. *Skin Pharmacol Appl Skin Physiol* 1998;11:52–6.
39. Piérard GE, Lévêque JL, Rougier A, Kligman AM. Dermo-epidermal stimulation elicited by a salicylic acid derivative. *Eur J Dermatol* 2002;12:S44–6.
40. U.S. Food and Drug Administration. Center for Food Safety and Applied Nutrition Office of Cosmetics and Colors Fact Sheet. Beta Hydroxy Acid in Cosmetics. March 7, 2000.
41. U.S. Food and Drug Administration. Center for Food Safety and Applied Nutrition Office of Cosmetics and Colors Fact Sheet. Alpha Hydroxy Acid in Cosmetics. July 3, 1997.

9

Kinetin

Stanley B. Levy

Introduction

Retinoids and hydroxy acids have successfully been used as active ingredients to improve the appearance of aging skin. However, both retinoids and hydroxy acids may be associated with skin irritation, stimulating a search for alternatives. Possible alternatives include kinetin (N6-furfuryladenine), zeatin, and pyratine-6. Kinetin and zeatin are members of a plant growth hormone family known as cytokinins, which have growth-promoting and antiaging effects in plants. Pyratine-6 (furfurylamino-tetrahydropyranlyadenine) is a synthetic analog of kinetin. The incorporation of these materials into cosmeceuticals is reviewed here.

Chemistry

Kinetin was first isolated from autoclaved herring sperm DNA in 1955^{1,2} and is a derivative of the nucleic acid purine base adenine. It is a naturally present base modification³ and is present in both plants^{4,5} and human cell extracts.⁶ The chemical structure of kinetin suggests that it can be formed from adenine and furfuryl (Figure 9.1). Furfuryl is formed after the primary oxidation of the deoxyribose moiety of DNA.⁷ It is not known how free kinetin is formed and if it is through the action of DNA repair enzymes that may remove this modified base from the DNA. Zeatin and pyratine-6 are derived from adenine as well. Zeatin contains adenine with the addition of an hydroxy-methylbutyl group (Figure 9.2); pyratine-6 is similar to kinetin except for the addition of a tetrahydropyranly group.

Biology

The first cytokinin identified^{1,2} and the most studied is kinetin. Cytokinins are plant growth substances that promote cell division and possibly cell differentiation. Plant-based studies are responsible for most of the data regarding the biological properties of kinetin. Kinetin stimulates tRNA synthesis⁸ and cell cycle progression⁹ in plants. Low levels of kinetin stimulate calcium influx through plant cell plasma membranes.¹⁰ Kinetin prevents yellowing and senescence of leaves and reduces the over ripening and degeneration of fruits.¹¹

Kinetin has been studied in human cells as well. Kinetin has antiaging effects on human skin cells and fruit flies.¹² Low levels of kinetin (10–20 ppm) delay the onset of biochemical and cellular changes associated with cellular aging in cell culture (Figure 9.3). Both relatively young and old cells were studied: fibroblasts that had completed less than 20% and older cells that had completed 90% or more of their potential *in vitro* life span were studied (Table 9.1). The studied cellular manifestations of *in vitro* aging included cell enlargement, presence of multi-nucleated giant cells, accumulation of cellular debris and lipofuscin, and changes in actin filaments and microtubules. These changes were attenuated with exposure to kinetin. Kinetin treatment decreased the age-associated reduction in cell yield (Figure 9.2). Kinetin did not alter the overall proliferation or the longevity of the cultured cells. Similar results were reported with zeatin with less toxicity at higher concentrations.¹³

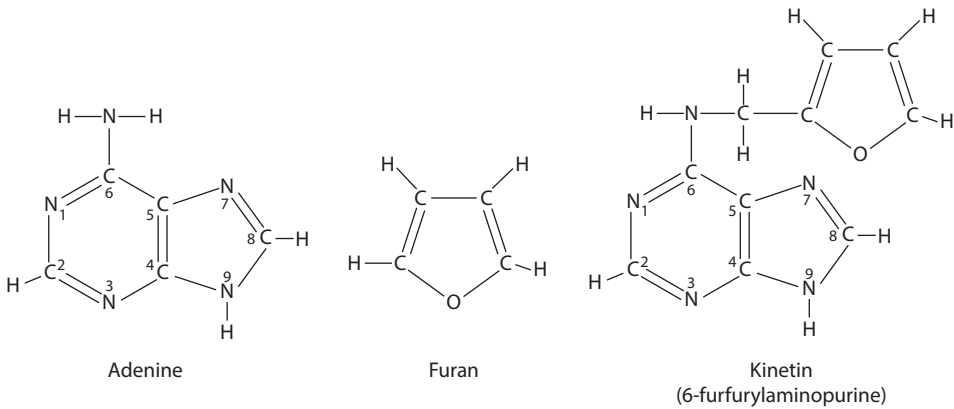

FIGURE 9.1 Chemical structure of adenine, furan, and kinetin.

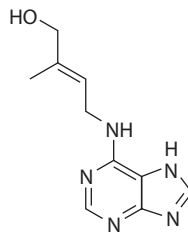

FIGURE 9.2 Chemical structure of zeatin.

A diet containing 20–50 ppm kinetin fed to fruit flies prolonged average and maximum life span by 65% and 35%, respectively.¹⁴ This was accompanied by a 55%–60% increase in the antioxidant enzyme catalase.¹⁵ Catalase is an enzyme that metabolizes hydrogen peroxide associated with cell toxicity.

Kinetin has inhibitory activity on free radical formation of active platelets *in vitro* and thrombus formation *in vivo*.¹⁶ This warrants further study of kinetin to mitigate arterial thrombosis, and further studies are needed to assess whether kinetin has a role in the prevention and treatment of arterial thrombosis.

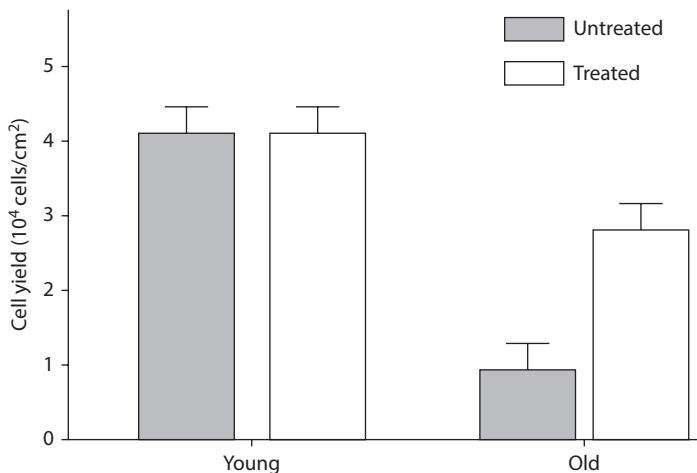

FIGURE 9.3 Cell yield in untreated and kinetin-treated young and old cells. (From Rattan SIS, Clark BFC. *Biochem Biophys Res Commun* 1994;201:665–72. With permission.)

TABLE 9.1Kinetin's Effects on the Cytological Manifestations of *In Vitro* Aging

Characteristic	Untreated		Kinetin	
	Young	Old	Young	Old
Cell enlargement	None	Significant	None	Insignificant
Multinucleate cells	None	Present	None	None
Cellular debris	Minimal	Significant	Minimal	Minimal
Lipofuscin	Low	High	Low	Low
Actin filaments	Diffuse	Highly polymerized	Diffuse	Less polymerized
Microtubules	Orderly	Disorganized	Orderly	Orderly

Source: From Rattan SIS, Clark BFC. *Biochem Biophys Res Commun* 1994;201:665–72. With permission.

A cytokinin nucleoside, N6-furfuryladenosine, has been shown to have antiproliferative and apoptogenic activity against various human cancer cell lines,¹⁷ although similar activity has not been shown with kinetin.

Mechanism of Action

Kinetin's mechanism remains unclear. Kinetin may act directly as a signaling molecule, stimulating defense pathways such as DNA repair.¹⁸ Kinetin promotes calcium-induced differentiation of human keratinocytes, which becomes progressively delayed during aging.^{19,20}

Kinetin is implicated in several antioxidative roles. Kinetin may function as a natural antioxidant,²¹ preventing the formation of reactive oxygen species, or as a direct free radical scavenger.²² Oxygen radicals abstract hydrogen from the α -carbon of the amine bond in N6-furfuryladenine²³ and these radicals undergo a faster dismutation reaction when kinetin is complexed with copper. Kinetin has been shown to protect against the formation of 8-oxo-2-deoxyguanosine, a marker of oxidative damage in DNA.²¹ Kinetin has also been shown to protect against oxidative and glycoxidative protein damage generated *in vitro* by sugars and an iron/ascorbate system.²²

The significance of kinetin's interaction with DNA or its antioxidant properties remains unknown. However, pluripotency may serve as a required prerequisite to act effectively as an agent of antiaging.²⁴ Both *in vitro* and *in vivo* studies comparing the oxidative stress capacity of multiple antioxidants demonstrated that kinetin was not as potent as others such as tocopherol and ascorbic acid, although it was more potent than lipoic acid.²⁵

Clinical Studies

In percutaneous absorption studies with human cadaver skin, kinetin demonstrated significant skin penetration (McCullough, unpublished study). A dose-response was exhibited from 0.01% to 0.05% kinetin with tissue levels for both serum and lotion formulations. There was no significant difference in transdermal absorption with the two test formulations. Topical treatment with low concentrations of kinetin lead to a more homogenous dispersion of melanin granules in the epidermis of dogs as well as reduced the stratum corneum thickness.²⁶ Although cosmetic formulations containing a dispersion of liposomes with multiple agents such as magnesium ascorbyl phosphate, alpha lipoic acid, and kinetin showed photoprotective effects,²⁷ a 0.5% kinetin solution and 0.1% kinetin cream showed no photoprotective effects by themselves.²⁸

In another study, topical kinetin 0.1% was applied twice daily for 24 weeks in 30 subjects with mild to moderate photodamaged facial skin.²⁹ Tactile roughness, mottled hyperpigmentation, and fine wrinkles were found to statistically improve at both 12 and 24 weeks. The overall photodamage was reported

improved by both self-assessment and dermatologist grading. Transepidermal water loss was decreased after 24 weeks, which is consistent with an improvement in the stratum corneum barrier function. Side effects were uncommon, with contact folliculitis noted as a side effect.

Ninety-eight subjects with mild to moderate photodamaged facial skin applied a kinetin-containing lotion and creams for 10 weeks (Revlon Research Center, unpublished studies). All subjects were assessed at baseline 4, 8, and 10 weeks for photodamage parameters. Statistically significant improvements were noted in all parameters, greatest with texture, skin clarity, discrete and mottled pigmentation, fine wrinkling, and global appearance. No significant irritation was noted.

Forty female subjects who ranged in age from 22 to 57, having mild to moderate facial skin photodamage, participated in a 12-week, split face, double-blind, controlled, and randomized study comparing a topical retinol against a topical kinetin-containing lotion twice daily (Almay Research—poster exhibit American Academy of Dermatology meeting, New Orleans, Louisiana, February 2002). Evaluations at four-week intervals demonstrated significant improvements for all attributes graded including discrete and mottled pigmentation, fine wrinkling, and overall photodamage. The kinetin containing lotion was found to have greater improvements in texture and clarity.

A clinical study demonstrated a beneficial effect of topical kinetin 0.1% lotion in reducing erythema and overall clinical scores in 17 subjects with mild to moderate rosacea.³⁰ No placebo control was utilized in this study and future studies of topical kinetin should incorporate a placebo. A study of topical kinetin 0.03% with niacinamide 4% in 52 Asian subjects over a 12-week period showed improvement in pore size and reduction of wrinkles.³¹

Nine kinetin-containing products in 200 subjects each were subject to modified Draize repeat insult patch tests. There were no instances of sensitization noted in the challenge phase. Controlled use testing for up to six weeks demonstrated no significant irritation (Almay research, unpublished studies). Six kinetin-containing products were tested in 10 subjects each with skin phototypes I–III for ultraviolet sensitivity when exposed to a solar simulator (Ivy Research Laboratory Inc., Philadelphia, Pennsylvania, unpublished study). Subjects were treated with once daily application of 2 mg/cm² at six sites on the mid-back over two weeks. No difference in the minimal erythema dose was demonstrated between untreated control and treated sites. These findings suggest that kinetin has minimal potential to cause irritation, allergy, or photosensitization.

A 12-week open label study on photoaging utilized furfuryl tetrahydropyranadenine (Pyratine-6). Improvements in hyperpigmentation, skin roughness, wrinkling, and moisturization were noted.³² The same analog showed a 44% reduction in the erythema severity score and an 89% reduction in the inflammatory lesion count of rosacea after 48 weeks of use in rosacea.³³ No placebo comparison group was utilized.

Conclusion

Kinetin (N6-furfuryladenine), a plant growth regulator, delays a range of cellular changes associated with the aging of human skin cells *in vitro*. In addition, kinetin has antioxidant properties. Clinical studies have demonstrated improvements in photodamaged skin. More active to vehicle comparison studies are needed.³⁴ Studies suggest that kinetin is not associated with significant irritation and may serve as a potential alternative for individuals sensitive to other topical agents such as retinoids and hydroxy acids. Analogs of kinetin appear promising for topical use.

REFERENCES

1. Miller CO, Skoog F, Von Saltza MH et al. Kinetin, a cell division factor from deoxyribonucleic acid. *J Am Chem Soc* 1955;77:1392.
2. Miller CO, Skoog F, Okumura FS et al. Isolation, structure, and synthesis of kinetin, a substance promoting cell division. *J Am Chem Soc* 1956;78:1375–80.
3. Barciszewski J, Siboska GE, Pedersen BO et al. A mechanism for the *in vivo* formation of N6-furfuryladenine, kinetin as a secondary oxidative damage product in DNA. *FEBS Lett* 1997;414:457–60.

4. Ramman N, Elumalai S. Presence of cytokinin in the root nodules of *Casuarina equisetifolia*. *Ind J Exp Biol* 1996;34:577–9.
5. Ratti N, Janardhanan KK. Effect on growth of and cytokinin contents of pamlrosa (*Cymbopogon martinii* var. *motia*) by Glomus inoculation. *Ind J Exp Biol* 1996;34:1126–8.
6. Barciszewski J, Siboska GE, Pedersen BO et al. Evidence for the presence of kinetin in DNA and cell extracts. *FEBS Lett* 1996;393:197–200.
7. Kahn QA, Hadi SM. Effect of furfural on plasmid DNA. *Biochem Mol Biol Int* 1993;29:1153–60.
8. Guadino RJ. Cytokinin induction of RNA polymerase I transcription in *Arabidopsis thaliana*. *J Biol Chem* 1997;272:6799–804.
9. Zhang K, Letham DS, John PC. Cytokinin controls the cell cycle at mitosis by stimulating the tyrosine dephosphorylation and activation of p34cdc-2-like H1 histone kinase. *Planta* 1996;200:2–12.
10. Shumaker KS, Gizinski MJ. Cytokinin stimulates dihydropyridine-sensitive calcium uptake in moss protoplasts. *Proc Natl Acad Sci USA* 1993;90:10937–41.
11. McFarland GA, Holliday R. Retardation of the senescence of cultured human diploid fibroblasts. *Exp Cell Res* 1994;212:167–75.
12. Rattan SIS, Clark BFC. Kinetin delays the onset of ageing characteristics in human fibroblasts. *Biochem Biophys Res Commun* 1994;201:665–72.
13. Ratan SIS, Sodagam L. Genomodulatory and youth-preserving effects of zeatin on human skin fibroblasts undergoing aging *in vitro*. *Rejuvenation Res* 2005;8(1):46–57.
14. Sharma SP, Kaur J, Rattan SIS. Plant growth hormone kinetin delays ageing, prolongs the lifespan and slows down development of the fruitfly *Zaprionus parvittiger*. *Biochem Biophys Res Commun* 1995;216:1067–71.
15. Sharma SP, Kaur J, Rattan SIS. Increased longevity of kinetin-fed *Zaprionus* fruitflies is accompanied by their reduced fecundity and enhanced catalase activity. *Biochem Mol Biol Int* 1997;41:869–75.
16. Hsiao G, Shen MY, Lin KH et al. Inhibitory activity of kinetin on free radical formation of active platelets *in vitro* and on thrombus formation *in vivo*. *Eur J Pharmacol* 2003;465(3):281–7.
17. Cabello CM, Bair WB, Ley S et al. The experimental chemotherapeutic N6-furfuryladenine (kinetin-riboside) induces rapid ATP depletion, genotoxic stress, and CDKN1A (p21) upregulation in human cancer cell lines. *Biochem Pharmacol* 2009;77:1125–38.
18. Barciszewski J, Massimo F, Clark BFC. Kinetin—A multiactive molecule. *Int J Biol Macromol* 2007;40:182–92.
19. Berge U, Kristensen P, Ratan SIS. Kinetin-induced premature aging and altered differentiation of normal human epidermal keratinocytes undergoing aging *in vitro*. *Ann NY Acad Sci* 2006;1067:332–6.
20. Berge U, Kristensen P, Ratan SIS. Hormetic modulation of differentiation of normal human epidermal keratinocytes undergoing replicative senescence *in vitro*. *Exp Gerontol* 2008;43:658–62.
21. Olsen A, Siboska GE, Clark BFC et al. N6-furfuryladenine, kinetin protects against Fenton reaction-mediated oxidative damage to DNA. *Biochem Biophys Res Commun* 1999;265:499–502.
22. Verbeke P, Siboska GE, Clark BFC et al. Kinetin inhibits protein oxidation and glyoxidation *in vitro*. *Biochem Biophys Res Commun* 2000;276:1265–70.
23. Rattan SIS. N6-furfuryladenine (kinetin) as a potential anti-aging molecule. *J Anti-Aging Med* 2002;5:113–6.
24. Hipkiss AR. On the “struggle between chemistry and biology during aging”—Implications for DNA repair, apoptosis and proteolysis, and a novel route of intervention. *Biogerontology* 2001;2(3):173–8.
25. McDaniel DH, Neudecker BA, DiNardo JC. Idebenone: A new antioxidant—Part I. Relative assessment of oxidative stress protection capacity compared to commonly known antioxidants. *J Cosmet Dermatol* 2005;4:10–7.
26. Kimura T, Kunio D. Depigmentation and rejuvenation effects of kinetin on the aged skin of hairless descendents of Mexican hairless dogs. *Rejuvenation Res* 2004;7:32–9.
27. Campos PM, de Carmago FB, de Andrade GJP et al. Efficacy of cosmetic formulations containing dispersion of liposome with magnesium ascorbyl phosphate, alpha-lipoic acid and kinetin. *Photochem Photobiol* 2012;66:748–52.
28. Tournia JA, Lin FH, Selim MA et al. Ubiquinone, idenone, and kinetin provide ineffective protection to skin when compared to a topical antioxidant combination of vitamins C and E with ferulic acid. *J Invest Dermatol* 2006;126:1185–7.
29. McCullough JL, Weinstein GD. Clinical study of safety and efficacy of using topical kinetin 0.1% (Kinerase) to treat photodamaged skin. *Cosmet Dermatol* 2002;15:29–32.

30. Wu JJ, Weinstein GD, Kricorian GJ et al. Topical kinetin 0.1% lotion for improving the signs and symptoms of rosacea. *Clin Exp Dermatol* 2007;32:693–5.
31. Chiu PC, Chan CC, Lin HM et al. The clinical anti-aging effects of topical kinetin and niacinamide in Asians: A randomized, double-blind, placebo-controlled, split-face comparative trial. *J Cosmet Dermatol* 2007;6:243–9.
32. McCullough JL, Garcia RL, Reece B. A clinical study of topical pyratine 6 for improving the appearance of photodamaged skin. *J Drugs Dermatol* 2008;7:131–5.
33. Tremaine AM, Ortiz A, Eikeeb L et al. Long-term efficacy and safety of topical PRK 124 (0.125%) lotion (Pyratine-XR) in the treatment of mild-to moderate rosacea. *J Drugs Dermatol* 2010;6:647–50.
34. Kligman C. Cosmeceuticals. *Dermatol Clin* 2000;18:609–15.

10

Topical Resveratrol

Andrea M. Hui, Jared R. Jagdeo, and Neil Brody

Introduction

Resveratrol has recently become popular as a component of topical cosmeceuticals for its anti-aging properties and other benefits (Table 10.1). It has a wide range of effects on the skin, including antioxidant properties, chemopreventive properties, anti-inflammatory and antimicrobial properties, and treatment of skin scarring and hyperpigmentation, among others. All of these properties make resveratrol an ideal addition to topical anti-aging cosmeceuticals.

Background

Resveratrol (3,5,4'-trihydroxystilbene) is an antioxidant polyphenol of the stilbene family, naturally found in the skin and seeds of red grapes. It has been popularized as the key ingredient in red wine, which helps to protect cardiovascular health. Resveratrol is also naturally found in other plants, berries, peanuts, and roots, where it plays an antioxidant role and protects plants against stressors such as ultra-violet (UV) light and fungal infections.¹

As a major constituent of red wine, resveratrol was studied in great detail for its medical benefits after Drs. Renaud and Lorgeiral noted a low incidence of heart disease in the French population whose diet is high in fat, the so-called “French paradox.” Epidemiological studies showed that high levels of red wine intake (20–30 g/day) were associated with a lower incidence of heart disease.² Since then, interest in resveratrol skyrocketed and many studies have been performed to investigate its health benefits.

Aging is caused by many different factors such as the loss of deep bone structure and subcutaneous fat, in addition to oxidative skin damage caused by cumulative sun exposure. The oxidative theory has become one of the most well studied causes of aging, as antioxidants have become a popular component in dietary and topical cosmeceuticals.

Here, we discuss the unique anti-aging properties of resveratrol, its targets, and its use in topical cosmeceuticals.

Cosmeceutical Uses

Resveratrol and Skin Barrier Penetration

The ability of any topical cosmeceutical to permeate the skin barrier is essential to its ability to reach actively metabolic cells and affect their processes. With UV radiation and exposure to exogenous stressors, the antioxidants present in skin can be significantly depleted, leaving the skin vulnerable to oxidative damage. It is therefore imperative that cosmeceuticals be able to penetrate the skin barrier to effectively deliver their antioxidant benefits. An effective topical antioxidant should be able to permeate the stratum corneum and reach the deeper layers of skin including the remainder of the epidermis and dermis. There should not be significant systemic absorption of the antioxidant component.

TABLE 10.1

Commercial Products Containing Resveratrol

Manufacturer	Other Featured Ingredients	Other Ingredients	Skin Type/Usage
Bite Beauty	5 mg resveratrol per lip product	Shea butter, beeswax, oils of jojoba seed, sesame, grapeseed	Makeup—lip color, anti-aging
B. Kamins laboratories	Vitamins C and E, HA	Extracts of maple, silybum marianum, carrot root, goji berry; oils of soybean, lemon peel, euterpe oleracea, vegetable oil	Anti-aging, antioxidant
Dr. Brandt	Extracts of green tea and white tea, vitamin E, HA	Aloe vera leaf powder, oils of rice bran, grape seed, canola; extracts of willow bark	Anti-aging for eye area, antioxidant
Jan Marini	Green tea polyphenols, white tea extract, HA	Extracts of pomegranate, rooibos tea cucumber; oils of Shea butter, safflower, sunflower, rose hip, almond	Anti-aging, antioxidant
Nia 24	Retinol, retinyl palmitate, HA, panthenol, vitamin E	Shea butter, jojoba, aloe barbaensis leaf juice, hexapeptide-3	Anti-aging, sensitive skin, hyperpigmentation
Skinceuticals	Baicalin, vitamin E	Niacinamide, caffeine	Anti-aging, antioxidant
StriVectin	HA, panthenol, vitamin E, ubiquinone, phospholipids, sphingolipids, arbutin	Shea butter, honey, oils of avocado, sunflower, olive	Anti-aging
Theraplex	HA, peptides	Squalene; oils of jojoba, apricot	Anti-aging
Topix	Green tea polyphenols, retinyl palmitate	Vitamin E, coQ10, biotin, sunscreens	Broad-spectrum sunscreen, antioxidant
Topix	Green tea polyphenols, ceramides, HA, caffeine	Extracts of yucca, Malus Domestica fruit cell, cholesterol, squalene	Anti-aging

Note: HA = hyaluronic acid.

An *in vitro* study by Abla and Banga³ investigated the permeation characteristics of resveratrol and other antioxidants. Resveratrol in a propylene glycol base was applied to porcine ear skin for 24 h and housed in a permeation unit (static Franz-type diffusion cells). Porcine skin was chosen for its high similarity to human skin. The polyphenols, which included resveratrol, catechin, and curcumin, showed a high concentration retained within the stratum corneum (90% retention) as compared with retinol, which permeated into the deeper layers of the skin (90% diffusion). Another similar *in vitro* mouse skin diffusion study by Hung et al.⁴ verified the retention of resveratrol within the stratum corneum. Moreover, *in vivo* permeation of mouse skin with topical resveratrol in various hydrogel bases for 12 h suggested the use of hydrogel to help retain resveratrol in the upper layers of skin.

A human skin diffusion study by Tfaili et al.⁵ investigated the cutaneous permeation of topical resveratrol and caffeine.⁵ A resveratrol solution (0.03 g/L) was applied to *ex vivo* human abdominal skin for 9 h. A permeation test was performed and Raman confocal microspectrometer was utilized to measure diffusion in real time. Both caffeine and resveratrol were found in higher concentrations in the superficial skin at 6 μM than at deeper layers.

These animal and human studies have shown resveratrol to be readily available in the stratum corneum, where the most exposure to reactive oxygen species (ROS) takes place, supporting the use of resveratrol in cosmeceuticals.

Antioxidant Properties

The skin is the largest organ in the body and is the outermost barrier. It is therefore frequently exposed to the oxidative stresses of everyday living, including UV radiation, air pollution, and toxins. This leads to the formation of ROS, hydrogen peroxide (H_2O_2), and free radicals, all of which can cause damage to DNA, RNA, lipids, and proteins within the skin. ROS is a well-known inducer of skin cancers, aging, and inflammation. Normal metabolic processes such as cytochrome P450 cycling⁶ and lipid peroxidation⁷ may also generate ROS, allowing free ROS to cause oxidative damage to cells within the body itself.

Skin has its own natural antioxidant system, which constantly neutralize ROS. This antioxidant system functions to chelate ROS or donate an electron to achieve stability.⁸ The skin's antioxidant system contains several lipophilic and hydrophilic antioxidants including vitamin E, vitamin C, glutathione, ubiquinones, and carotenoids, among others.⁹ These antioxidants have been found throughout the skin. Several studies have shown that the amount of antioxidants present in the epidermis is greater than in the dermis,^{10–13} which is due to the fact that the outer layers of skin are most exposed to oxidative stressors.^{13,14}

Resveratrol is best known for its antioxidant properties. The cumulative oxidative damage caused by both UVA and UVB irradiation produces excess ROS. Additionally, oxidative processes such as glycation can cross-link glycosaminoglycans (GAGs) within the dermis, which can create the yellow-brown sallow complexion characteristic of photoaged skin.^{15–17}

To study the antioxidant capabilities of resveratrol against UVA, Chen et al.¹⁸ performed an *in vitro* study utilizing immortalized human keratinocyte cells (HaCaT cells). The HaCaT cells were subjected to UVA irradiation at a dose of 5 J/cm² while incubated with either 0.01 mmol/L or 0.1 mmol/L of resveratrol. It was found that resveratrol was able to enhance cell proliferation, increase the activity of antioxidants superoxide dismutase (SOD) and glutathione peroxidase, decrease the amount of oxidative by-products such as maleic dialdehyde, and prevent injury to HaCaT cell ultrastructure in a dose-dependent manner.

There are other antioxidant properties of resveratrol. Resveratrol itself is able to directly scavenge free radicals such as hydroxyl, superoxide, and metal/enzymatic-induced and cellular generate radicals.¹⁹ It can also prevent lipid peroxidation through chelation of copper and works synergistically with other antioxidants such as alpha-tocopherol (vitamin E).²⁰ Overall, resveratrol upregulates the expression of the transcription factor nuclear factor-E2-related factor-2 (Nrf2), which regulates several genes that help synthesize more antioxidants and remove ROS. These genes encode enzymes such as glutathione peroxidase, catalase, superoxide dismutase, and hemoxygenase-1.^{21,22} All of these properties support the use of resveratrol as a potent antioxidant.

Skin Barrier Repair

Photoprotective Properties

UVR radiation has been implicated in the development of about 90% of non-melanoma skin cancers, as well as melanoma and precancerous actinic keratoses.^{23–26} Chronic DNA damage, either directly through UV-induced cell death pathways, or indirectly through formation of damaging ROS, leads to the development of non-melanoma skin cancers. UVB radiation also leads to other adverse effects such as erythema, edema, inflammation, hyperplasia, hyperpigmentation, immunosuppression, and, over time, skin aging.^{26–29} Avoidance of unnecessary sun exposure and use of sunblock is the mainstay in photoprotective measures. More recently, chemoprevention with resveratrol and other antioxidants³⁰ has shown promise in helping to prevent UV-induced skin cancers.^{31,32}

The photoprotective function of resveratrol may be secondary to its anti-apoptotic effects. Bastianetto et al.³³ investigated the specific resveratrol binding sites within human epidermis. Human HaCaT cells were incubated with sodium nitroprusside (SNP), a nitric oxide (NO) free radical donor, which resulted in cell death. Resveratrol (1–30 μ M) significantly reduced SNP-induced toxicity beginning at a concentration of 10 μ M.

Utilizing autoradiography, a significant amount of specific [³H]-resveratrol binding sites within the HaCaT cell epidermis as compared to the dermis, with a majority of sites found within the granular layer. Additionally, resveratrol inhibited mitochondrial apoptotic events triggered by SNP (via inhibition of caspase-3) and reduced the number of apoptotic cells.

Resveratrol is able to ameliorate the damages caused by short-term UVB exposure to skin through several mechanisms. In a mouse study by Afaq et al.,³⁴ a single topical application of resveratrol (25 μ M/0.2 mL acetone) to SKH-1 hairless mice was found to significantly inhibit UVB (180 mJ/cm²)-mediated increase in skin thickness and skin edema. Topical application of resveratrol also significantly inhibited UVB-mediation induction of the tumor-promoting enzymes cyclooxygenase and ornithine

decarboxylase. Additionally, topical resveratrol inhibited UVB-mediated lipid peroxidation and generation of hydrogen peroxide (H_2O_2), markers of oxidative stress.

In a similar study by Aziz et al.,³¹ the use of topical resveratrol was shown to upregulate specific proteins that can assist in chemoprevention of UVB-induced skin cancers. SKH-1 hairless mice were irradiated with 180 mJ/cm² twice weekly for 28 weeks. The mice received either pretreatment (30 minutes before UVB exposure) or post-treatment (five minutes after UVB exposure) topical resveratrol at either 25 or 50 μ M/0.2 mL acetone. Topical resveratrol was found to significantly inhibit and delay the onset of tumor development when applied before or after UVB exposure. This suggested that resveratrol did not work via a sunscreen mechanism. Survivin, a critical regulator of survival and death in cells (upregulation is associated with several cancers), was found to be significantly elevated with UVB exposure, as well as its mRNA. Treatment with resveratrol to the mice downregulated both Survivin protein and its mRNA. This suggested that resveratrol enhanced chemoprotective effects against UVB-induced skin carcinogenesis and may be mediated through mechanisms such as downregulation of Survivin.

Resveratrol is also able to block nuclear factor kappa B (NF-kappaB), which is known to play a significant role in the development of skin cancer. In a study by Adhami et al.,³⁰ normal human epidermal keratinocytes (NHEK) were pre-treated with various concentrations of resveratrol (0–25 μ M) for 24 h and then exposed to UVB radiation (40 mJ/cm²). Pre-incubation with resveratrol blocked UVB-mediated activation of NF-kappaB in a dose-dependent and time-dependent (5 μ M resveratrol for 12, 24, and 48 hours) manner. Additionally, treatment of NHEK with resveratrol inhibited UVB-mediated (1) phosphorylation and degradation of I κ B α , and (2) activation of IKK α , both of which play a critical role in photocarcinogenesis. All of these mechanisms support the use of resveratrol against the adverse effects of UV-induced photocarcinogenesis.

Photoaging and Hyperpigmentation

Photoaging is caused in part by cumulative sun exposure, which produces excess ROS and resultant oxidative damage to the skin. Oxidative processes such as end-glycation can cross-link sugars and proteins. These proteins aggregate between collagen bundles in the aging dermis, causing the characteristic sallow appearance of photoaged skin.^{15–17,35} Additionally, loss of bone structure and subcutaneous fat, or the “foundation,” further contributes to an aged appearance.

The breakdown of collagen is another causative factor in aging skin. ROS can also upregulate photoaging transcription factors such as activator protein 1 (AP-1) and NF-kappaB, as discussed earlier.^{36,37} AP-1 is an essential transcription factor in the production of metalloproteinases (MMPs), which are enzymes that break down collagen. The loss of collagen and accumulation of end-glycation products cause the skin to become thin and wrinkled. Several *in vitro* studies have shown that resveratrol can downregulate both AP-1 and NF-kappaB, which would in turn help to prevent the premature breakdown of collagen associated with aging skin.^{30,36}

Additionally, post-menopausal women lose around 1% of their collagen every year.³⁸ This is thought to be secondary to the loss of estrogen, as replacement therapy helps to prevent collagen loss.^{39,40} The chemical structure of resveratrol is similar to diethylstilbestrol, a synthetic estrogen. Gehm et al.⁴¹ showed that resveratrol at concentrations comparable to those required for biological effects of estrogen (approximately 3–10 μ M), resveratrol was able to inhibit the binding of labeled estradiol to estrogen receptors. Resveratrol also activated the transcription of estrogen-responsive reporter genes. Therefore, resveratrol can function as a phytoestrogen and estrogen beta-receptor agonist. Further studies should be performed to investigate the use of resveratrol as a topical anti-aging cosmeceutical with similar collagen-boosting effects of estrogen, which can decrease the associated risk factors of oral estrogen use.

Facial hyperpigmentation can also contribute to an aged appearance and can be distressing. There are several types of irregular hyperpigmentation. Post-inflammatory hyperpigmentation can result after an inflammatory dermatosis or irritation, in which increased melanin production or transfer of melanin to keratinocytes is induced by skin injury. Melasma presents as symmetric hyperpigmented patches and is common among females of young- to middle-aged and Fitzpatrick skin types IV–VI. Causative factors include increased amounts of melanin in response to sun exposure, oral contraceptives, and pregnancy.⁴²

Studies have shown that stilbenes such as resveratrol are potent tyrosinase inhibitors.⁴³ Newton et al.⁴³ investigated the mechanisms by which resveratrol could prevent hyperpigmentation. Cultured human melanocytes were treated with resveratrol 20 $\mu\text{g/mL}$ for 24 h, which significantly decreased *in situ* tyrosinase activity without adversely affecting cell viability or numbers. This decrease in tyrosinase activity was time-dependent, requiring 18–24 h of exposure for a maximum of 80% tyrosinase inhibition. Additionally, resveratrol caused a significant reduction of tyrosinase protein levels that correlated with the decrease in tyrosinase activity.

Scarring

Wound healing is a complex process. Scar formation is a response to local tissue injury; inflammation, cell migration and proliferation, and synthesis of the extracellular matrix (ECM) components such as collagen are the processes by which scars are formed. Hypertrophic and keloid scars are an abnormal form of wound healing characterized by excessive fibroblast proliferation and collagen production after injury. Keloids extend upwards and beyond the original site of the scar onto normal adjacent skin, while hypertrophic scars are within the margins of the original site of injury. Hypertrophic scars present as erythematous, itchy, raised lesions on the site of the skin injury. These can cause a negative psychosocial impact in affected patients. First- and second-line treatments include intralesional corticosteroids, excision, skin grafting, and pressure therapy, among others.

Zeng et al.⁴⁴ investigated whether resveratrol could inhibit the proliferation of fibroblasts in order to suggest the use of resveratrol for the treatment of hypertrophic scars. Human hypertrophic scar tissue was isolated from 20–30 year old females and the fibroblasts were isolated. The fibroblasts were incubated with various concentrations of resveratrol (0–400 μM) for 12–72 hours. Resveratrol was shown to markedly alter cell morphology after incubation with 150 μM resveratrol. Cell proliferation was significantly inhibited in a dose- and time-dependent manner. Specifically, treatment with resveratrol caused fibroblast cell cycle arrest at the G₁/S phase and induced apoptosis in a dose- and time-dependent manner.

The investigators also investigated whether resveratrol would also reduce collagen. The human fibroblast cells were incubated with resveratrol at various concentrations (75–300 μM) for 24 hours. Production of the collagen precursor hydroxyproline was significantly decreased in a time-dependent manner when fibroblasts were treated with 150 μM resveratrol for 24, 48, and 72 hours. To measure collagen levels, RT-PCR was performed to look for mRNA expression of type I and III procollagen; incubation of fibroblasts with resveratrol led to a significant reduction in the levels of mRNA for both type I and III procollagen.

Transforming growth factor-beta 1 (TGF- β 1) is a key mediator in fibrogenesis and is upregulated in keloid tissue and other diseases such as systemic sclerosis in which fibroblasts are overactive.^{45,46} TGF- β 1 promotes type I collagen synthesis and inhibits the transcription of collagenase, allowing for the overproduction of collagen found in keloids.⁴⁷ In a study by Ikeda et al.,⁴⁸ treatment of human keloid fibroblasts with varying concentrations of resveratrol (0, 25, 50, or 100 μM) caused a significant decrease in the expression of type I collagen, a smooth muscle actin, and heat shock protein 47 in a dose-dependent manner. Additionally, resveratrol significantly decreased TGF- β 1 production by keloid fibroblasts. Most importantly, resveratrol suppressed the proliferation of keloid fibroblasts and induced apoptosis of these fibroblasts. These findings did not occur in normal skin fibroblasts.

These results suggested resveratrol as a possible compound for the treatment of hypertrophic scars.

Wound Healing

Wound healing is a dynamic, complex, restorative process in response to skin injury. There are three phases involved in wound healing: inflammation, proliferation, and maturation and remodeling. The immediate inflammatory phase is characterized by activation of the local innate immune system, which leads to an influx of neutrophils and macrophages. This phase is significant for the release of cytokines and growth factors, such as IL-1, IL-6, vascular endothelial growth factor (VEGF), TNF, and TGF- β . VEGF is a mediator for the development of endothelial cells and helps to regulate angiogenesis. Both

VEGF and nitric oxide (NO) stimulate wound healing by causing inflammation, angiogenesis, endothelial and epithelial cell proliferation, extracellular matrix formation, and remodeling.^{49,50}

Resveratrol may be useful for improving wound healing. It has been reported to stimulate endothelial NO synthase (eNOS) activity and VEGF expression, therefore promoting angiogenesis and wound healing by improving blood supply.^{51–53} Yaman et al.⁵⁴ performed a controlled rat study to investigate the effects of oral resveratrol on incisional wound healing in rats (n = 10 per group). Adult female Wistar-Albino rats were orally administered resveratrol 0.5 mg/kg once daily for seven days until 12 hours before surgery. A 4-cm midline laparotomy was performed, and then treatment was maintained until the rats were sacrificed at post-operative day 7 or 14. Tensile strength and histology of the wounds were measured, along with hydroxyproline levels, which would be indicative of collagen deposition. It was found that oral resveratrol significantly increased tensile strength of the abdominal fascia and increased hydroxyproline levels by postoperative day 14. Additionally, neovascularization on postoperative days 7 and 14 were significantly higher in the resveratrol treatment group compared with control. Granulation tissue and fibroblast maturation scores were also significantly higher for the resveratrol treatment group when compared with control. These findings showed that resveratrol might be a useful adjunct for wound healing.

Other Uses of Resveratrol

Resveratrol may be useful in other areas of medicine. It is known that resveratrol is naturally produced by several plants, including peanuts, mulberries, and skins of certain grapes, when under attack by bacterial or fungal pathogens. An *in vitro* study by O'Connor et al.⁵⁵ showed that resveratrol significantly inhibited the growth of the gram-negative anaerobic bacteria *A. actinomycetemcomitans* and *P. gingivalis*, which are some of the causative bacteria in periodontal disease associated with tissue destruction. The bacteria were incubated with resveratrol (in DMSO, 0.052 g/mL) for 1, 3, 6, and 24 hours in an anaerobic chamber at 37°C. At each time interval, the cultures were plated on blood agar plates and colony growth was observed. Resveratrol significantly decreased viable counts at 1 hour of incubation, and continued being reduced in a time-dependent manner, and at 24 hours, no colonies were able to grow.

In a similar study, Nawrocki et al.⁵⁶ investigated the bactericidal effects of resveratrol against *Haemophilus ducreyi*, the Gram-negative bacterium responsible for the sexually transmitted disease chancroid. The minimum cidal concentration (MCC) of resveratrol was found to be 500 µg/mL, which caused a 99.99% decrease in viable bacteria. Resveratrol activity against *Lactobacillus* strains was also investigated to determine any negative effects on natural flora. The MCC of resveratrol at 500 µg/mL caused an insignificant decrease in *Lactobacillus* growth, even when co-cultured with *H. ducreyi*, demonstrating that resveratrol was safe to normal flora.

These studies suggested resveratrol as an effective antimicrobial.

Acne

As mentioned earlier, resveratrol is a natural phytoalexin exhibiting natural antimicrobial and anti-inflammatory properties. Acne vulgaris is one of the most common skin disorders seen by dermatologists, affecting patients from infancy into adulthood. There are many different causes of acne, most commonly beginning with hormonal changes in puberty, which leads to stimulation of sebaceous glands within an obstructed pilosebaceous unit; this creates a favorable environment for bacteria to play a pathogenic role in inflammatory acne. The causative bacterium, *Propionibacterium acnes*, induces inflammation in the comedo by inducing the release of neutrophils and pro-inflammatory cytokines, which causes the characteristic inflamed lesions of acne. First-line treatments for acne include oral and topical antibiotics, which are often combined with comedolytic treatments such as topical retinoids and salicylic acid.

There has been growing concern for the increasing resistance of *P. acnes* to multiple antibiotics used in the treatment of acne, such as erythromycin.^{57–59} This has encouraged the development of alternative topical treatments that do not cause bacterial resistance such as benzoyl peroxide (BP), which functions to directly kill bacteria via oxidative damage. However, BP often causes skin irritation and dryness.

Resveratrol has been shown to eradicate *P. acnes* in an *in vitro* experiment by Coenye et al.⁶⁰ Various *P. acnes* strains were isolated from human facial acne and plated to biofilm formation. The plates were washed and then incubated with 118 other various plant extracts, including resveratrol, for 24 hours. Only five compounds were capable of significantly reducing more than 50% of biofilms when tested at a concentration of 0.1% (w/v). The minimum inhibitory concentration of resveratrol was found to be 0.625% (% w/v) after various dilutions were tested for anti-biofilm activity. This *in vitro* experiment showed resveratrol as a promising agent against *P. acnes*.

The use of resveratrol for the treatment of clinical inflammatory acne was investigated by Fabbrocini et al.⁶¹ in a single-blind, vehicle-controlled pilot study. Resveratrol was incorporated into a carboxymethylcellulose-based gel at a concentration of 0.01%. Twenty patients were treated with the formula applied to one side of the face once daily for 60 days. Clinical evaluation utilizing a standardized Global Acne Grading System showed a significant mean reduction of 53.75% in acne lesions on the resveratrol-treated side of the face versus 6.10% on the vehicle-treated side of the face. Interestingly, histologic analysis showed a 66.7% mean reduction in the average area of micro-comedones on the resveratrol-treated side of the face, versus a 9.7% reduction on the vehicle-treated side. All 20 patients were satisfied with the active treated size and tolerated the resveratrol gel very well without side effects. This study presented resveratrol as an effective treatment for acne vulgaris.

Conclusion

Resveratrol, a powerful antioxidant polyphenol naturally found in the skin and seeds of red grapes, offers a wide range of skincare benefits. These include antioxidant and chemopreventive properties, anti-inflammatory properties, improvement of wound healing and hyperpigmentation, and anti-microbial properties. These qualities have brought resveratrol to the forefront as a highly effective ingredient in topical cosmeceuticals.

REFERENCES

1. Favaron F, Lucchetta M, Odorizzi S, Pais da Cunha A, Sella L. The role of grape polyphenols on trans-resveratrol activity against *Botrytis cinerea* and of fungal laccase on the solubility of putative grape PR proteins. *J Plant Pathol* 2009;91(3):579–88.
2. Renaud S, de Lorgeril M. Wine, alcohol, platelets, and the French paradox for coronary heart disease. *Lancet* 1992;339(8808):1523–6.
3. Abla MJ, Banga AK. Quantification of skin penetration of antioxidants of varying lipophilicity. *Int J Cosmet Sci* 2013;35(1):19–26.
4. Hung CF, Lin YK, Huang ZR, Fang JY. Delivery of resveratrol, a red wine polyphenol, from solutions and hydrogels via the skin. *Biol Pharm Bull* 2008;31(5):955–62.
5. Tfaili S, Josse G, Angiboust JF, Manfait M, Piot O. Monitoring caffeine and resveratrol cutaneous permeation by confocal Raman microspectroscopy. *J Biophotonics* 2013;5(10):201300011.
6. Borek C. Molecular mechanisms in cancer induction and prevention. *Environ Health Perspect* 1993;101(Suppl 3):237–45.
7. Devasagayam TP, Kesavan PC. Radioprotective and antioxidant action of caffeine: Mechanistic considerations. *Indian J Exp Biol* 1996;34(4):291–7.
8. Kohen R, Nyska A. Oxidation of biological systems: Oxidative stress phenomena, antioxidants, redox reactions, and methods for their quantification. *Toxicol Pathol* 2002;30(6):620–50.
9. Kohen R. Skin antioxidants: Their role in aging and in oxidative stress—New approaches for their evaluation. *Biomed Pharmacother* 1999;53(4):181–92.
10. Kohen R, Oron M, Zelkowitz A, Kanevsky E, Farfour S, Wormser U. Low molecular weight antioxidants released from the skin's epidermal layers: An age dependent phenomenon in the rat. *Exp Gerontol* 2004;39(1):67–72.
11. Weber SU, Thiele JJ, Cross CE, Packer L. Vitamin C, uric acid, and glutathione gradients in murine stratum corneum and their susceptibility to ozone exposure. *J Invest Dermatol* 1999;113(6):1128–32.

12. Hellemans L, Corstjens H, Neven A, Declercq L, Maes D. Antioxidant enzyme activity in human stratum corneum shows seasonal variation with an age-dependent recovery. *J Invest Dermatol* 2003;120(3):434–9.
13. Thiele JJ, Traber MG, Packer L. Depletion of human stratum corneum vitamin E: An early and sensitive *in vivo* marker of UV induced photo-oxidation. *J Invest Dermatol* 1998;110(5):756–61.
14. Herkenne C, Naik A, Kalia YN, Hadgraft J, Guy RH. Effect of propylene glycol on ibuprofen absorption into human skin *in vivo*. *J Pharm Sci* 2008;97(1):185–97.
15. Wu JT. Advanced glycosylation end products: A new disease marker for diabetes and aging. *J Clin Lab Anal* 1993;7(5):252–5.
16. Crisan M, Taulescu M, Crisan D et al. Expression of advanced glycation end-products on sun-exposed and non-exposed cutaneous sites during the ageing process in humans. *PLoS One* 2013;8(10):0075003.
17. Pagon H, Zucchi H, Rousset F, Monnier VM, Asselineau D. Skin aging by glycation: Lessons from the reconstructed skin model. *Clin Chem Lab Med* 2014;52(1):169–74.
18. Chen ML, Li J, Xiao WR et al. Protective effect of resveratrol against oxidative damage of UVA irradiated HaCaT cells. *Zhong Nan Da Xue Xue Bao Yi Xue Ban* 2006;31(5):635–9.
19. Leonard SS, Xia C, Jiang BH et al. Resveratrol scavenges reactive oxygen species and effects radical-induced cellular responses. *Biochem Biophys Res Commun* 2003;309(4):1017–26.
20. Fang JG, Lu M, Chen ZH et al. Antioxidant effects of resveratrol and its analogues against the free-radical-induced peroxidation of linoleic acid in micelles. *Chemistry* 2002;8(18):4191–8.
21. Ungvari Z, Orosz Z, Rivera A et al. Resveratrol increases vascular oxidative stress resistance. *Am J Physiol Heart Circ Physiol* 2007;292(5):12.
22. Harikumar KB, Aggarwal BB. Resveratrol: A multitargeted agent for age-associated chronic diseases. *Cell Cycle* 2008;7(8):1020–35.
23. Stern RS. Prevalence of a history of skin cancer in 2007: Results of an incidence-based model. *Arch Dermatol* 2010;146(3):279–82.
24. Black HS, deGrujil FR, Forbes PD et al. Photocarcinogenesis: An overview. *J Photochem Photobiol B* 1997;40(1):29–47.
25. Soehnge H, Ouhitit A, Ananthaswamy ON. Mechanisms of induction of skin cancer by UV radiation. *Front Biosci* 1997;1(2):d538–51.
26. Matsumura Y, Ananthaswamy HN. Molecular mechanisms of photocarcinogenesis. *Front Biosci* 2002;1(7):d765–83.
27. Brash DE, Ziegler A, Jonason AS, Simon JA, Kunala S, Leffell DJ. Sunlight and sunburn in human skin cancer: p53, apoptosis, and tumor promotion. *J Investig Dermatol Symp Proc* 1996;1(2):136–42.
28. Matsumura Y, Ananthaswamy HN. Toxic effects of ultraviolet radiation on the skin. *Toxicol Appl Pharmacol* 2004;195(3):298–308.
29. Ananthaswamy HN, Loughlin SM, Ullrich SE, Kripke ML. Inhibition of UV-induced p53 mutations by sunscreens: Implications for skin cancer prevention. *J Investig Dermatol Symp Proc* 1998;3(1):52–6.
30. Adhami VM, Afaq F, Ahmad N. Suppression of ultraviolet B exposure-mediated activation of NF-kappaB in normal human keratinocytes by resveratrol. *Neoplasia* 2003;5(1):74–82.
31. Aziz MH, Reagan-Shaw S, Wu J, Longley BJ, Ahmad N. Chemoprevention of skin cancer by grape constituent resveratrol: Relevance to human disease? *Faseb J* 2005;19(9):1193–5.
32. Jang M, Cai L, Udeani GO et al. Cancer chemopreventive activity of resveratrol, a natural product derived from grapes. *Science* 1997;275(5297):218–20.
33. Bastianetto S, Dumont Y, Duranton A, Vercauteren F, Breton L, Quirion R. Protective action of resveratrol in human skin: Possible involvement of specific receptor binding sites. *PLoS One* 2010;5(9):0012935.
34. Afaq F, Adhami VM, Ahmad N. Prevention of short-term ultraviolet B radiation-mediated damages by resveratrol in SKH-1 hairless mice. *Toxicol Appl Pharmacol* 2003;186(1):28–37.
35. Wilson SL, Guilbert M, Sule-Suso J et al. A microscopic and macroscopic study of aging collagen on its molecular structure, mechanical properties, and cellular response. *Faseb J* 2014;28(1):14–25.
36. Kundu JK, Shin YK, Surh YJ. Resveratrol modulates phorbol ester-induced pro-inflammatory signal transduction pathways in mouse skin *in vivo*: NF-kappaB and AP-1 as prime targets. *Biochem Pharmacol* 2006;72(11):1506–15.
37. Avouac J, Palumbo K, Tomecik M et al. Inhibition of activator protein 1 signaling abrogates transforming growth factor beta-mediated activation of fibroblasts and prevents experimental fibrosis. *Arthritis Rheum* 2012;64(5):1642–52.

38. Raine-Fenning NJ, Brincat MP, Muscat-Baron Y. Skin aging and menopause: Implications for treatment. *Am J Clin Dermatol* 2003;4(6):371–8.
39. Castelo-Branco C, Duran M, Gonzalez-Merlo J. Skin collagen changes related to age and hormone replacement therapy. *Maturitas* 1992;15(2):113–9.
40. Hall G, Phillips TJ. Estrogen and skin: The effects of estrogen, menopause, and hormone replacement therapy on the skin. *J Am Acad Dermatol* 2005;53(4):555–68.
41. Gehm BD, McAndrews JM, Chien PY, Jameson JL. Resveratrol, a polyphenolic compound found in grapes and wine, is an agonist for the estrogen receptor. *Proc Natl Acad Sci U S A* 1997;94(25):14138–43.
42. Grimes PE, Yamada N, Bhawan J. Light microscopic, immunohistochemical, and ultrastructural alterations in patients with melasma. *Am J Dermatopathol* 2005;27(2):96–101.
43. Newton RA, Cook AL, Roberts DW, Leonard JH, Sturm RA. Post-transcriptional regulation of melanin biosynthetic enzymes by cAMP and resveratrol in human melanocytes. *J Invest Dermatol* 2007;127(9):2216–27.
44. Zeng G, Zhong F, Li J, Luo S, Zhang P. Resveratrol-mediated reduction of collagen by inhibiting proliferation and producing apoptosis in human hypertrophic scar fibroblasts. *Biosci Biotechnol Biochem* 2013;77(12):2389–96.
45. Varga J, Pasche B. Transforming growth factor beta as a therapeutic target in systemic sclerosis. *Nat Rev Rheumatol* 2009;5(4):200–6.
46. Lu L, Saulis AS, Liu WR et al. The temporal effects of anti-TGF-beta1, 2, and 3 monoclonal antibody on wound healing and hypertrophic scar formation. *J Am Coll Surg* 2005;201(3):391–7.
47. Bettinger DA, Yager DR, Diegelmann RF, Cohen IK. The effect of TGF-beta on keloid fibroblast proliferation and collagen synthesis. *Plast Reconstr Surg* 1996;98(5):827–33.
48. Ikeda K, Torigoe T, Matsumoto Y, Fujita T, Sato N, Yotsuyanagi T. Resveratrol inhibits fibrogenesis and induces apoptosis in keloid fibroblasts. *Wound Repair Regen* 2013;21(4):616–23.
49. Diegelmann RF, Evans MC. Wound healing: An overview of acute, fibrotic and delayed healing. *Front Biosci* 2004;9:283–9.
50. Schaffer MR, Tantry U, Efron PA, Ahrendt GM, Thornton FJ, Barbul A. Diabetes-impaired healing and reduced wound nitric oxide synthesis: A possible pathophysiologic correlation. *Surgery* 1997;121(5):513–9.
51. Sen CK, Khanna S, Gordillo G, Bagchi D, Bagchi M, Roy S. Oxygen, oxidants, and antioxidants in wound healing: An emerging paradigm. *Ann NY Acad Sci* 2002;957:239–49.
52. Petrat F, de Groot H. Protection against severe intestinal ischemia/reperfusion injury in rats by intravenous resveratrol. *J Surg Res* 2011;167(2):29.
53. Penumathsa SV, Thirunavukkarasu M, Koneru S et al. Statin and resveratrol in combination induces cardioprotection against myocardial infarction in hypercholesterolemic rat. *J Mol Cell Cardiol* 2007;42(3):508–16.
54. Yaman I, Derici H, Kara C et al. Effects of resveratrol on incisional wound healing in rats. *Surg Today* 2013;43(12):1433–8.
55. O'Connor DJ, Wong RW, Rabie AB. Resveratrol inhibits periodontal pathogens *in vitro*. *Phytother Res* 2011;25(11):1727–31.
56. Nawrocki EM, Bedell HW, Humphreys TL. Resveratrol is cidal to both classes of *Haemophilus ducreyi*. *Int J Antimicrob Agents* 2013;41(5):477–9.
57. Nakase K, Nakaminami H, Noguchi N, Nishijima S, Sasatsu M. First report of high levels of clindamycin-resistant *Propionibacterium acnes* carrying erm(X) in Japanese patients with acne vulgaris. *J Dermatol* 2012;39(9):794–6.
58. Eady EA, Gloor M, Leyden JJ. *Propionibacterium acnes* resistance: A worldwide problem. *Dermatology* 2003;206(1):54–6.
59. Cooper AJ. Systematic review of *Propionibacterium acnes* resistance to systemic antibiotics. *Med J Aust* 1998;169(5):259–61.
60. Coenye T, Brackman G, Rigole P et al. Eradication of *Propionibacterium acnes* biofilms by plant extracts and putative identification of icariin, resveratrol and salidroside as active compounds. *Phytomedicine* 2012;19(5):409–12.
61. Fabbrocini G, Staibano S, De Rosa G et al. Resveratrol-containing gel for the treatment of acne vulgaris: A single-blind, vehicle-controlled, pilot study. *Am J Clin Dermatol* 2011;12(2):133–41.

11

Impact of Rhodiola rosea on Skin

Mahtab Jafari

Rhodiola rosea

Rhodiola rosea (*R. rosea*) belongs to the plant family of *Crassulaceae* and grows primarily in high altitudes in the mountainous arctic areas of Tibet, Russia, China, and India. In addition to *R. rosea*, 200 other species of *Rhodiola* have been identified, and 20 of them are currently used in traditional medical systems to combat a number of physical and mental disorders such as depression, anxiety, and fatigue.¹ In 1775, *R. rosea* was listed in the first Swedish pharmacopeia with all its medicinal properties² and it has been the most studied *Rhodiola* species in Russia, China, Scandinavia,³ and more recently in the United States. In 1948, two Russian scientists evaluated the chemical composition and biological activities of a number of herbs, including *R. rosea*. They discovered that some herbs protected against a variety of biological, environmental, and psychological stressors. Based on their work, the term “adaptogen” was coined and *R. rosea* was considered a potent adaptogenic herb.⁴

Phytochemistry of *R. rosea*

Phytochemical evaluation of *R. rosea* root reveals the presence of as many as 140 compounds.⁵ Many of these compounds are also found in other *R. rosea* species, but the presence of three phenylpropanoids (rosavin, rosin, and rosarin) is unique to *R. rosea*⁶ (Figure 11.1). *Rhodiola rosea* extracts that have been used in animal and clinical studies are usually standardized to a minimum of 3% phenylpropanoids (rosavin, rosin, and rosarin) and 1% of the phenyl ethanol derivatives (salidroside and tyrosol).⁷

Health Benefits of *R. rosea*

An impressive but still limited body of literature supports the health benefits of *R. rosea* without any reported serious adverse effects. As early as the 1940s, Russian government scientists observed that the plant boosted the body’s response to stress. They also observed that unlike amphetamines and stimulant substances, *R. rosea* was not addictive and it did not result in a “crash” or a rebound period of profound fatigue.⁸ In recently published studies, *R. rosea* resulted in significant improvement in stress induced physical and mental fatigue in medical students under examination, night duty physicians, and military cadets.^{9,10} Based on observational and prospective clinical studies, the plant appears promising in improving mental and physical performance in stressful conditions. Because of these published studies, *R. rosea* has become a popular dietary supplement. Today, many people consume *R. rosea* in an attempt to improve physical and mental performances. Early Soviet studies on *R. rosea* are summarized in the National Pharmacopeia of the USSR in a chapter titled “*R. rosea* Rhizome and Roots.”¹¹

Mechanistically, the plant is purported to work centrally and peripherally on monoamine and opioid synthesis, transport, and receptor activity.^{12,13} In doses ranging from 150 mg to 300 mg, *R. rosea* has been found to stimulate the release of dopamine (DA), and serotonin (5-HT).¹ Over seven decades of research, *R. rosea* has passed extensive toxicological studies and is considered a safe plant for human use.¹⁴

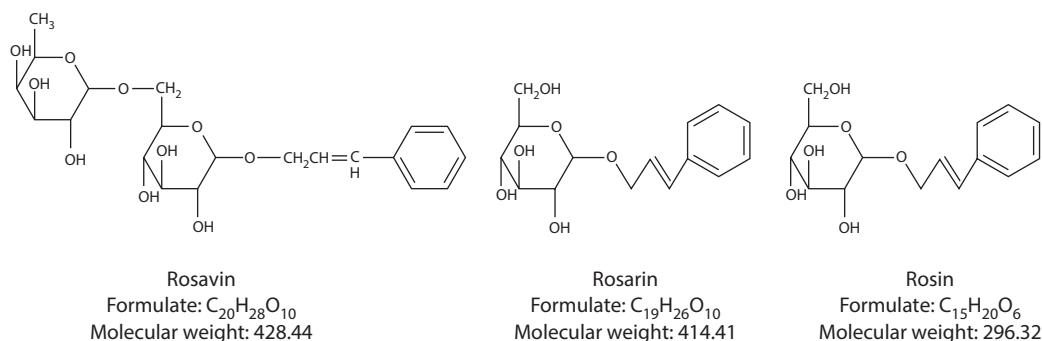

FIGURE 11.1 Chemical structures of rosavin, rosin, and rosarin.

In spite of a number of reported clinical benefits with *R. rosea* as an anti-oxidative, anti-cancer, anti-viral, anti-stress, anti-anxiety, and anti-depressive agent, many of these studies lack solid research methodologies and reproducibility.

***Rhodiola rosea* as an Anti-Aging Botanical Extract**

According to a number of reports, alcoholic and aqueous extracts of *Rhodiola* species have significant free radical scavenging activities. These activities are often attributed to the existence of a variety of antioxidant compounds such as p-tyrosol, organic acids (gallic acid, caffeic acid, and chlorogenic acid), and flavonoids (catechins and pro-anthocyanidins) in *Rhodiola* species.^{15,16} In a study that examined the active oxygen scavenging activity of traditional nourishing tonic herbal medicines, it was reported that 19 isolated compounds in a *Rhodiola* species, *R. sacra*, had scavenging activities against superoxide anion and hydroxyl radicals.¹⁷ In another study, *R. rosea* lowered mitochondrial superoxide levels and afforded elevated protection against the superoxide generator paraquat in fruit flies.¹⁸ The anti-aging and lifespan extension properties of *R. rosea* appears to be conserved in model species such as yeasts, worms, and flies.^{18–21} These observations suggest that *R. rosea* may be a viable treatment to slow aging and abrogate age-related diseases in a range of species, potentially including humans.

The Impact of *R. rosea* on Cultured Skin Cells

The skin is continuously subjected to environmental oxidative stresses such as UVA/UVB, abrasive liquids, radiation, and air pollution, among others.²² This creates an abundance of free radicals, which damage DNA and other macromolecules, disrupt the normal cell cycle, and can lead to chronic skin diseases such as psoriasis and skin cancer.²³ Preventive measures such as sunscreen and protective clothing are readily available, yet skin cancer is still the most common cancer in the United States (Centers for Disease Control [CDC]). While studies of *R. rosea* for skin application are limited, the extract appears as a potential antioxidant, which may prove useful in restoring normative cellular function to skin cells.

Keratinocytes comprise most of the epidermis—the outermost layer of the skin—and contain an antioxidant system for protection. This inherent shielding capacity includes the enzymes catalase (CAT), superoxide dismutase (SOD), and glutathione peroxidase (GPx), which protect and regulate glutathione (GSH) and glyceraldehyde-3-phosphate dehydrogenase (GAPDH). When exposed to oxidative compounds *in vitro*, human keratinocytes that were pre-incubated with *R. rosea* extract exhibited higher SOD and CAT activity, but after cells were stressed, only GSH was protected, not GAPDH.²⁴ The efficacy of *R. rosea* varies with the type of oxidative insult, preserving cell membrane integrity for 24 hours in some cases.²⁴ Keratinocytes undergoing radiation or extreme temperatures as a method of creating oxidative damage had increased cell viability when pre-incubated with *R. rosea*²⁵ or salidroside.²⁶ Use of *R. rosea* after UV exposure also appeared to mediate the inflammatory and immune response,

normalizing multiple neuropeptides and cytokines that responded in a dose-dependent manner.²⁷ The skin is also comprised of adipocytes and nerve cells, both of which exhibited elevated oxygen respiration when *R. rosea* was used.²⁵ This observed metabolic increase suggests improved health and capability of nerve cells to signal, as well as the breakdown of triglycerides to glycerol.²⁵

The mechanism of action of *R. rosea* when it comes to antioxidant activity and cell survival is not yet established. The protective effects of *R. rosea* are not only limited to skin cells. In a recent study, it was reported that *R. rosea* protected two other cell lines *in vitro* as well. Surprisingly, in this study, the upregulation of major antioxidant defenses (SOD, CAT, GPx) was not reported as the main cause.²⁸

Rhodiola rosea has also been tested as an immunomodulator compound to ameliorate sensitive skin.²⁷ Keratinocytes that were exposed to ultraviolet radiation were incubated with various doses of *R. rosea*/L-carnosine-associated compound (RCAC) for 48 hours. A dose-dependent return of the pro-inflammatory and immunosuppressive cytokines, interleukin 1 alpha, interleukin-10, and tumor necrosis factor alpha to baseline levels was observed. *Rhodiola rosea*/L-carnosine-associated compound (RCAC) also resulted in the reduction of neurotransmitters involved in inflammatory response, calcitonin-related peptide (CGRP), substance P and also an increase in POMC (an antagonist to proinflammatory cytokines). These observations were also validated in a randomized placebo controlled clinical study by the same authors in the same publication using an RCAC serum. The RCAC serum group reported increased skin comfort and a reduced dryness sensation. These observations suggest that RCAC may be beneficial in the treatment of sensitive skin disorders.²⁷

The impact of *Rhodiola* species and their putative active compounds has also been tested on skin pigmentation disorders with non-conclusive results.²⁹ Tyrosinase is considered a major enzyme in skin pigmentation disorders in the elderly. In a recent study, using guinea pig skin, salidroside, a major putative active compound in *R. rosea*, was tested as an inhibitor of melanogenesis and tyrosinase activity of skin cells. UV radiation was used to induce and upregulate tyrosinase activity and melanosomes, two factors that contribute to the formation of irregular pigmentation in skin tissue. Topical application of salidroside did appear effective in melanin synthesis inhibition compared to the control group, with similar efficacy to other melanin suppressing compounds such as arbutin and peonol. This study suggests testing topical salidroside in pigmentation disorders and for skin lightening after prolonged UV exposure, but further clinical studies must be completed to validate these results.²⁹ In another study, the inhibitory effects of a number of *Rhodiola* species and their putative active compounds were tested on tyrosinase activation. The oligomeric proanthocyanidins (OPCs) commonly found in *Rhodiola* species resulted in anti-tyrosinase activity but salidroside did not show any inhibitory effects on tyrosinase activity.³⁰ Since these studies had conflicting results, the impact of *R. rosea* on skin pigmentation disorders needs to be evaluated in future clinical studies.

Although there are only a few published studies on the protective effects of *R. rosea* on skin, this botanical extract appears to be promising as a protective skin therapy. Future clinical studies are needed to validate and confirm the findings of the *in vitro* studies.

***Rhodiola rosea* and Potential Skin Applications**

Rhodiola rosea creams and lotions are available from a variety of manufacturers, many of which advertise their products as wrinkle reducing skin care products. While these claims may be based on small human clinical trials, *R. rosea* is among many ingredients used in these skin products and the observed benefits cannot be solely attributed to *R. rosea*.

Skin-related research that does isolate *R. rosea* directly relating to topical use is limited to few *in vivo* animal and human studies concerning ectopic tumors, wound healing, and skin sensitivity.

Cutaneous angiogenesis from grafted syngeneic tumors on Balb/c mice was significantly reduced by oral administration of *R. rosea* extract. This followed a dose response curve (50–400 µg), with higher concentrations yielding greater inhibition of blood vessel differentiation.³¹ Similar results were obtained in a parallel study utilizing human kidney cancer tissue grafts instead of the syngeneic tumors.³¹ The mechanism in which *R. rosea* inhibits angiogenesis is unclear, but there appears to be a definitive correlation between ingesting *R. rosea* and controlling malignant cutaneous angiogenesis.

Accelerated wound healing was reported in a pilot study utilizing another species of *Rhodiola*, *R. imbricata*.³² Rats were subjected to dermal wounds and were treated with topical *R. imbricata* extract or a providone-iodine ointment as a control. The treatment group wound sites contracted faster, and contained elevated levels of DNA and collagen precursors.³² A higher level of this ubiquitous structural protein is critical to dermal repair as well as restoration of skin elasticity. Since *R. imbricata* upregulated multiple cytokines and overall cell immunity,³³ it was purported that *R. imbricata* had immunomodulation properties, which expedited wound healing.

R. rosea was also utilized along with the lactic acid stinging test in which volunteers reported increased skin comfort and reduced dryness sensation after application of *R. rosea*/L-carnosine-associated compound (RCAC) for 28 days, when compared to a placebo group.²⁷ A smaller but significant subgroup of the test also measured for water loss from the skin, which was decreased after 28 and 56 days.

Cosmetic manufacturers have reported positive impacts of topical *R. rosea*, but since their products are composed of a number of active ingredients, the benefits cannot be attributed to *R. rosea* only.

Conclusion

A limited yet promising body of literature suggests that *R. rosea* may be used to prevent and manage skin aging, malignant cutaneous angiogenesis, wound healing, and skin sensitivity. Since the majority of the benefits are observed in *in vitro* and animal studies, controlled clinical studies are needed to validate the use of *R. rosea* in topical products to protect human skin.

REFERENCES

1. Brown RP, Gerbarg PL, Ramazanov Z. *Rhodiola rosea*: A phytomedicinal overview. *HerbalGram* 2002;(56):40–52.
2. Pharmacopoeia Svecia, Holmia, 39, 1775.
3. Khanum F, Bawa SW, Singh B. *Rhodiola rosea*: A versatile adaptogen. *Comprehensive Rev Food Sci Food Safety* 2005;4(3):55–62.
4. Panossian A, Wikman G, Wagner H. Plant adaptogens. III. Earlier and more recent aspects and concepts on their mode of action. *Phytomedicine* 1999;6(4):287–300.
5. Panossian A, Wikman G, Sarris J. Rosenroot (*Rhodiola rosea*): Traditional use, chemical composition, pharmacology and clinical efficacy. *Phytomedicine* 2010;17(7):481–93.
6. Kelly GS. *Rhodiola rosea*: A possible plant adaptogen. *Altern Med Rev* 2001;6(3):293–302.
7. Perfumi M, Mattioli L. Adaptogenic and central nervous system effects of single doses of 3% rosavin and 1% salidroside *Rhodiola rosea* L. extract in mice. *Phytother Res* 2007;21(1):37–43.
8. Olsson EM, von Scheele B, Panossian AG. A randomised, double-blind, placebo-controlled, parallel-group study of the standardised extract shr-5 of the roots of *Rhodiola rosea* in the treatment of subjects with stress-related fatigue. *Planta Med* 2009;75(2):105–12.
9. Fintelmann V, Gruenwald J. Efficacy and tolerability of a *Rhodiola rosea* extract in adults with physical and cognitive deficiencies. *Adv Ther* 2007;24(4):929–39.
10. Darbinyan V, Kteyan A, Panossian A et al. *Rhodiola rosea* in stress induced fatigue—A double blind cross-over study of a standardized extract SHR-5 with a repeated low-dose regimen on the mental performance of healthy physicians during night duty. *Phytomedicine* 2000;7(5):365–71.
11. Pereulok P. *National Pharmacopoeia of the USSR* 11th edition. Moscow: Medizina; 1998.
12. Lishmanov Iu B, Naumova AV, Afanes'ev SA et al. Contribution of the opioid system to realization of inotropic effects of *Rhodiola rosea* extracts in ischemic and reperfusion heart damage *in vitro*. *Eksp Klin Farmakol* 1997;60(3):34–6.
13. Maimeskulova LA, Maslov LN, Lishmanov Iu et al. The participation of the mu-, delta- and kappa-opioid receptors in the realization of the anti-arrhythmia effect of *Rhodiola rosea*. *Eksp Klin Farmakol* 1997;60(1):38–9.
14. Kurkin VA, Zapesochnaya GG. Chemical composition and pharmacological characteristics of *Rhodiola rosea*. *J Med Plants* 1985;20(10):1231–445.

15. Boon-Niermeijer EK, van den Berg A, Wikman G et al. Phyto-adaptogens protect against environmental stress-induced death of embryos from the freshwater snail *Lymnaea stagnalis*. *Phytomedicine* 2000;5(5):389–99.
16. Kim SH, Hyun SH, Choung SY. Antioxidative effects of *Cinnamomi cassiae* and *Rhodiola rosea* extracts in liver of diabetic mice. *Biofactors* 2006;26(3):209–19.
17. Ohsugi M, Fan W, Hase K et al. Active-oxygen scavenging activity of traditional nourishing- tonic herbal medicines and active constituents of *Rhodiola sacra*. *J Ethnopharmacol* 1999;67(1):111–9.
18. Schriener SE, Abrahamyan A, Avanesian A et al. Decreased mitochondrial superoxide levels and enhanced protection against paraquat in *Drosophila melanogaster* supplemented with *Rhodiola rosea*. *Free Radic Res* 2009;43(9):836–43.
19. Bayliak MM, Lushchak VI. The golden root, *Rhodiola rosea*, prolongs lifespan but decreases oxidative stress resistance in yeast *Saccharomyces cerevisiae*. *Phytomedicine* 2011;18(14):1262–8.
20. Wiegant FA, Surinova S, Ytsma E et al. Plant adaptogens increase lifespan and stress resistance in *C. elegans*. *Biogerontology* 2009;10(1):27–42.
21. Schriener SE, Lee K, Truong S et al. Extension of *Drosophila* lifespan by *Rhodiola rosea* through a mechanism independent from dietary restriction. *PLoS One* 2013;8(5):e63886.
22. Lopez-Torres M, Thiele JJ, Shindo Y et al. Topical application of alpha-tocopherol modulates the antioxidant network and diminishes ultraviolet-induced oxidative damage in murine skin. *Br J Dermatol* 1998;138(2):207–15.
23. Trouba KJ, Hamadeh HK, Amin RP et al. Oxidative stress and its role in skin disease. *Antioxid Redox Signal* 2002;4(4):665–73.
24. Calcabrini C, De Bellis R, Mancini U et al. *Rhodiola rosea* ability to enrich cellular antioxidant defences of cultured human keratinocytes. *Arch Dermatol Res* 2010;302(3):191–200.
25. Gruber JV, Qi J, Bouldin L et al. *Rhodiola rosea*: The influence of an adaptogen on cutaneous cellular metabolisms. *Cosmetic Sci Technol* 2006;64–72.
26. Zhou MJ, Zheng L, Guo L et al. Differential responses to UVB irradiation in human keratinocytes and epidermoid carcinoma cells. *Biomed Environ Sci* 2012;25(5):583–9.
27. Dieamant Gde C, Velazquez Pereda Mdei C, Eberlin S et al. Neuroimmunomodulatory compound for sensitive skin care: *In vitro* and clinical assessment. *J Cosmet Dermatol* 2008;7(2):112–9.
28. Schriener SE, Avanesian A, Liu Y et al. Protection of human cultured cells against oxidative stress by *Rhodiola rosea* without activation of antioxidant defenses. *Free Radic Biol Med* 2009;47(5):577–84.
29. Peng LH, Liu S, Xu SY et al. Inhibitory effects of salidroside and paeonol on tyrosinase activity and melanin synthesis in mouse B16F10 melanoma cells and ultraviolet B-induced pigmentation in guinea pig skin. *Phytomedicine* 2013;20(12):1082–7.
30. Chen BF, Yang YF, Zhang YT. Inhibitory effects of *Rhodiola* plants and their oligomeric proanthocyanidins on tyrosinase and Abeta42 aggregation. *Yao Xue Xue Bao* 2012;47(11):1440–6.
31. Skopinska-Rozewska E, Malinowski M, Wasitynski A et al. The influence of *Rhodiola quadrifida* 50% hydro-alcoholic extract and salidroside on tumor-induced angiogenesis in mice. *Pol J Vet Sci* 2008;11(2):97–104.
32. Gupta A, Kumar R, Upadhyay NK et al. Effects of *Rhodiola imbricata* on dermal wound healing. *Planta Med* 2007;73(8):774–7.
33. Mishra KP, Padwad YS, Jain M et al. Aqueous extract of *Rhodiola imbricata* rhizome stimulates pro-inflammatory mediators via phosphorylated IkappaB and transcription factor nuclear factor-kappaB. *Immunopharmacol Immunotoxicol* 2006;28(2):201–1.

12

Silymarin

Andrew Mamalis and Jared R. Jagdeo

Introduction

Silymarin is a botanical extract derived from milk thistle. There are several studies that have evaluated individual components of silymarin in dermatology, and fewer studies that have evaluated the properties of unfractionated silymarin in skin.

Silymarin Antioxidant Properties in Skin

Silymarin is a naturally occurring compound that has demonstrated anti-oxidant properties in skin cells. Flavonoids and flavonolignans represent the main classes of components that comprise silymarin, and studies have demonstrated the ability of both of these components to reduce the generation of hydrogen peroxide in keratinocytes and also limit hydrogen peroxide associated skin cell death.^{1,2}

Our research group recently demonstrated the biphasic dose dependent anti-oxidant function of unfractionated silymarin in normal human skin fibroblasts *in vitro*.³ It was interesting that the lowest dose, 0.0001% of silymarin, produced the best anti-oxidant effect in our *in vitro* model of hydrogen peroxide induced oxidative stress. This work is particularly important, as it highlights the importance of preclinical research to select the appropriate concentration of anti-oxidants to best protect against oxidative stress in skin. This premise of preclinical testing of anti-oxidant capability *in vitro* is not limited to silymarin alone, and extends to other anti-oxidants, wherein preclinical testing can help optimize the selection of the concentrations of natural products to be incorporated into topical cosmeceuticals for patient use. To our knowledge, there are no published studies that have evaluated the anti-oxidant capabilities of silymarin on human skin *in vivo*.

Another research group recently demonstrated the anti-oxidant abilities of silymarin in mouse skin derived CD11b+ lymphocytes.⁴ In this study, silymarin was able to decrease reactive oxygen species production in ultraviolet (UV)-induced oxidative stress in these infiltrating lymphocytes. In conjunction with our silymarin research, this research demonstrates that silymarin is able to function as an anti-oxidant through inhibition of reactive oxygen species generation in a variety of skin cells.

Silymarin Photoprotective Properties in Skin

Silymarin has demonstrated photoprotective properties in skin animal models. In a murine model, silymarin treatment decreased UVB-generated intracellular hydrogen peroxide production in the epidermal and dermal layers of the skin.⁵ Furthermore, in this same study, silymarin was able to protect against UVB-induced sunburn.⁵

Furthermore, silibinin, a chief component of silymarin, was shown to demonstrate photoprotective properties in human skin via modulation of reactive oxygen species free radical-associated pathways.^{6,7} An additional study demonstrated that silymarin was able to protect against UVB-induced keratinocyte

apoptosis via anti-oxidant mechanisms and silymarin facilitated increased repair of UVB-induced DNA damage by upregulation of nucleotide excision repair.⁸

Silymarin Anticancer Properties in Skin

Silymarin has demonstrated anti-cancer properties in cutaneous models. We anticipate that due to silymarin's photoprotective and anti-cancer properties, silymarin will begin to feature prominently in future topicals aimed at ultraviolet sunscreen and anti-cancer protection. In a murine study, silymarin reduced UVB-induced melanoma tumor incidence and volume.⁵ Topical application of silymarin in other murine skin models have demonstrated mechanistic anti-cancer properties through reduction of 12-O-tetradecanoylphorbol-13-acetate (TPA)-induced ornithine decarboxylase (ODC), a well-studied compound associated with tumor promotion via effects on the cell cycle.^{9,10}

Silymarin Anti-Fibrotic Properties in Skin

Silymarin has demonstrated anti-fibrotic properties in *in vitro* models. Treatment of primary human skin fibroblasts with silymarin led to downregulation of type I collagen synthesis.¹¹ This downregulation in collagen was demonstrated to result from inhibition of the TGF-beta pathway by regulation of Smad2/3 signaling.¹¹ In addition, silymarin increased matrix metalloproteinase (MMP)-1 and MMP-2 levels. These findings suggest that silymarin may hold potential for treatment or prevention of fibrotic diseases, such as keloids and hypertrophic scars.

The scientific foundation for the inclusion of silymarin in topical products for the purpose of anti-oxidation, anti-cancer, anti-fibrotic, and photoprotection is well supported by several preclinical studies outlined in this chapter. We anticipate and look forward to future translational research demonstrating the beneficial properties in human skin clinically.

REFERENCES

1. Svobodova A, Walterova D, Psotova J. Influence of silymarin and its flavonolignans on H(2)O(2)-induced oxidative stress in human keratinocytes and mouse fibroblasts. *Burns* 2006;32:973–9.
2. Svobodova A, Zdarilova A, Walterova D, Vostalova J. Flavonolignans from *Silybum marianum* moderate UVA-induced oxidative damage to HaCaT keratinocytes. *J Dermatol Sci* 2007;48:213–24.
3. Mamalis A, Nguyen DH, Brody N, Jagdeo J. The active natural anti-oxidant properties of chamomile, milk thistle, and halophilic bacterial components in human skin *in vitro*. *J Drugs in Dermatol* 2013;12:780–4.
4. Katiyar SK, Meleth S, Sharma SD. Silymarin, a flavonoid from milk thistle (*Silybum marianum* L.), inhibits UV-induced oxidative stress through targeting infiltrating CD11b+ cells in mouse skin. *Photochem Photobiol* 2008;84:266–71.
5. Katiyar SK. Treatment of silymarin, a plant flavonoid, prevents ultraviolet light-induced immune suppression and oxidative stress in mouse skin. *Int J Oncol* 2002;21:1213–22.
6. Narayanapillai S, Agarwal C, Deep G, Agarwal R. Silibinin inhibits ultraviolet B radiation-induced DNA-damage and apoptosis by enhancing interleukin-12 expression in JB6 cells and SKH-1 hairless mouse skin. *Mol Carcinog* 2014;53(6):471–9.
7. Narayanapillai S, Agarwal C, Tilley C, Agarwal R. Silibinin is a potent sensitizer of UVA radiation-induced oxidative stress and apoptosis in human keratinocyte HaCaT cells. *Photochem Photobiol* 2012; 88:1135–40.
8. Katiyar SK, Mantena SK, Meeran SM. Silymarin protects epidermal keratinocytes from ultraviolet radiation-induced apoptosis and DNA damage by nucleotide excision repair mechanism. *PLoS One* 2011;6:e21410.

9. Agarwal R, Katiyar SK, Lundgren DW, Mukhtar H. Inhibitory effect of silymarin, an anti-hepatotoxic flavonoid, on 12-O-tetradecanoylphorbol-13-acetate-induced epidermal ornithine decarboxylase activity and mRNA in SENCAR mice. *Carcinogenesis* 1994;15:1099–103.
10. Mallikarjuna G, Dhanalakshmi S, Singh RP, Agarwal C, Agarwal R. Silibinin protects against photocarcinogenesis via modulation of cell cycle regulators, mitogen-activated protein kinases, and Akt signaling. *Cancer Res* 2004;64:6349–56.
11. Cho JW, Il KJ, Lee KS. Downregulation of type I collagen expression in silibinin-treated human skin fibroblasts by blocking the activation of Smad2/3-dependent signaling pathways: Potential therapeutic use in the chemoprevention of keloids. *Int J Mol Med* 2013;31:1148–52.

13

Topical Niacinamide

Andrea M. Hui and Bishr Al Dabagh

Introduction

Niacinamide, also known as nicotinamide, is an increasingly popular component of topical cosmeceuticals. It has shown a wide variety of benefits such as improving epidermal barrier function and therefore inflammatory dermatoses, increasing protein and ceramide synthesis, and improving photoaged skin color and texture, among others. This chapter reviews the role of niacinamide in skincare and its future applications.

Background

Biochemistry and Pharmacology

Nicotinic acid and nicotinamide are the two principle forms of vitamin B3, also known as niacin. Niacin is a pyridine derivative with a carboxyl group at the 3-position; replacement of the carboxyl group (–COOH) with a carboxamide group (–CONH₂) yields nicotinamide. Niacin was first described in 1873 by Hugo Weidel while studying nicotine, and was extracted from the liver in 1937 by Conrad Elvehjem.^{1,2} The preparation was shown to prevent pellagra in humans and canine black tongue. The name niacin is derived from the combination of nicotinic acid + vitamin. Two very important coenzymes, nicotinamide adenine dinucleotide (NAD) and nicotinamide adenine dinucleotide phosphate (NADP) are involved in catabolic and anabolic processes respectively via hydrogen transfer reactions. NAD(P) is a coenzyme of over 200 metabolic enzymes and acts as a signal transducer as well. Nicotinamide is produced from tryptophan metabolism with 60 mg of tryptophan (along with vitamin B6, iron, and riboflavin) required to synthesize 1 mg of niacin.³ It is also obtained from the diet (poultry, meat, fish, nuts, whole grains, eggs, dates, legumes, mushrooms, avocados, among other sources). It is rapidly absorbed in the gastrointestinal tract and excreted by the liver. Unlike nicotinic acid, systemic absorption does not cause flushing, elevation in blood pressure, pulse, or body temperature. The recommended daily allowance is 2–12 mg/day for children, 14–16 mg/day for adults, and 18 mg/day for pregnant women. Niacin status is checked through urinary markers.

Role in Skin Diseases

A deficiency of NAD and NADP is attributed to a triad of effects termed pellagra. Given the coenzymes role in metabolism, pellagra affects tissues with high cell turnover rates (skin, gut) and those with high energy demands (brain).⁴ Classically, it consists of diarrhea, dementia, dermatitis, and if severe enough, may eventuate in death. The classic pattern may not be evident and only some features may manifest. Pellagra is endemic in the developing world and unfortunate populations afflicted by war or famine. It is quite rare in the developed world and it is usually associated with alcoholism due to a combination of intestinal malabsorption and poor diet.⁴ Other rare causes of pellagra include conditions that predispose to intestinal malabsorption (Crohn's disease, Hartnup disease, intestinal parasites), anorexia, medications (anti-tuberculosis and anti-epileptic), HIV infection, and recreational drugs.⁴ Skin manifestations

include a photodistributed erythema that becomes scarlet or hyperpigmented with scaling and crust, a well demarcated band around the neck, termed Casal's necklace, painful fissuring of the hands and feet, peri-oral and peri-anal erythema and skin breakdown, cheilitis, glossitis, and vaginitis with ulcerations.⁵ Due to large tissue stores, symptoms appear after months of niacin or tryptophan deficit. Photosensitivity may be the first cutaneous sign of pellagra. Histologically, pellagra is non-specific and mimics other nutritional deficiencies, showing keratinocytic pallor and ballooning degeneration of the upper third of the epidermis and in severe cases, blistering may occur. Treatment of pellagra consists of oral supplementation (usually with nicotinamide due to less side effects) and if possible, correction of the underlying condition. Zinc, vitamin B6, and magnesium should also be supplemented since they are co-factors in niacin synthesis.⁴

Medical Applications

Oral niacin is prescribed as an anti-atherosclerotic agent and may also be antiatherogenic. It increases high density lipoproteins (HDL) (independent factor in preventing cardiovascular effects), decreases low density lipoproteins (LDL) and triglycerides. Niacin and statin combinations may be used to further reduce cardiovascular risk. The major effect of niacin is through partial inhibition of lipolysis of fat, thus decreasing free fatty acid delivery to the liver and reducing very low density lipoproteins (VLDL) production. Additionally, it directly acts on vessel endothelium, preventing expression of adhesion molecules, on macrophages inhibiting homing to atherosclerotic lesions and increasing the efflux of free cholesterol onto HDL particles.⁶ As stated previously, the major side effect of niacin (flushing) is due to vasodilation by prostaglandin release and possible serotonin release by platelets.⁶

Nicotinamide is a potent inhibitor of proinflammatory cytokines including interleukin-1 β (IL-1 β), IL-6, IL-8, and tumor necrosis factor- α (TNF- α).⁷ Systemically, nicotinamide has been studied in the treatment of psoriasis vulgaris due to its anti-inflammatory effects, decreasing toxicity of methotrexate, and aiding TNF- α inhibitors in the treatment of arthritis.⁸ In bullous pemphigoid, it may prevent the complement inflammatory cascade at the epidermal/dermal junction.⁹ Inhibition of intercellular adhesion molecule-1 (ICAM-1) may be the mechanism nicotinamide prophylaxis against polymorphous light eruption.¹⁰ Other diseases treated by systemic nicotinamide include stroke, schizophrenia, radiotherapy induced hypoxia, and opioid addiction.³

Topical Use

Treatment of Photoaging

Aging is caused by many different factors such as the loss of deep bone structure and subcutaneous fat, in addition to oxidative skin damage caused by cumulative sun exposure. Oxidative processes such as glycation (also known as the Maillard reaction) are spontaneous oxidative processes that cross-link sugars and proteins.¹¹ The resultant dermal glycosaminoglycans (GAGs) are yellow-brown in color and characteristic of photoaged skin.¹²⁻¹⁵ These cross-linked proteins can aggregate in between the long-lasting collagen fibers in the aging dermis, which can contribute to the yellowing, sallow appearance of aging skin. There are studies indicating a fivefold increase in collagen glycation products in human skin from age 20 to 80.¹⁶ In patients with diabetes, increased blood glucose levels can also increase glycation and can lead to noticeably yellower skin, or "yellow skin syndrome."¹⁷

As mentioned earlier, niacinamide is a precursor to the co-factors NAD and NADP and their reduced form, NADH and NADPH. The reduced forms serve as potent antioxidants.¹⁸ In fact, NADH has greater reducing ability when compared with other vitamins such as C and E.¹⁸ In aging skin, there are reduced levels of NADH and NADPH, which are vital to cell metabolism and epidermal turnover. Topical application of niacinamide can increase levels of NADH and NADPH, which therefore inhibit the formation of glycation end-products and the sallowness associated with aging skin.

In a clinical study by Bisset et al.,¹⁹ topical 5% niacinamide in an oil-in-water moisturizer commercial product (not identified) was applied to the face twice daily for 12 weeks (n = 50, healthy Caucasian

females age 40–60). This study was double-blind, placebo-controlled, split-face, and side-randomized and results were captured and assessed digitally and subjectively. Topical 5% niacinamide prevented facial skin red blotchiness and hyperpigmentation compared with the control. Additionally, treatment with the same topical 5% niacinamide moisturizer also resulted in a small but significant reduction in fine lines/wrinkles at the end of 12 weeks of treatment compared with control. Sallowiness was also assessed; at the 8- and 12-week mark, topical 5% niacinamide was significantly effective at preventing skin yellowing. The anti-aging effects of this well tolerated topical 5% niacinamide formula was thought secondary to a reduction in excess GAG production in the dermis.

Epidermal Barrier Function Repair

The primary role of the skin is to protect against injury, regulate temperature, and prevent water loss. Skin irritation and inflammation is often a function of an impaired skin barrier function.²⁰ In dry environments, inflammatory conditions such as atopic dermatitis, psoriasis, and pruritus are often aggravated.²¹ When levels of humidity are less than 10%, the stratum corneum actively begins to lose moisture.²² Hot water, harsh soaps and detergents, and scrubbing can strip the skin of naturally occurring protective lipids, further compromising the skin barrier.²³

Water is integral to a properly functioning stratum corneum. Enzymes within the stratum corneum need water in order to degrade the corneodesmosomes, allowing for normal desquamation.²⁴ Keratinocytes then flatten and extrude lipids; these keratinocytes cornify and become corneocytes to provide a thick, protein-rich cornified envelope. This cornified envelope affords an insoluble barrier of highly cross-linked keratin bundles.²⁵ The corneocytes are held together tightly by lipids, consisting mostly of ceramides, free fatty acids, and cholesterol.²⁶ These stratum corneum lipids play a vital role in skin barrier homeostasis. For example, low levels of ceramides occur in atopic dermatitis and aging skin.^{27,28} Environmental changes such as cold weather and low humidity can also decrease levels of stratum corneum lipids and cause a decrease in ceramides.²⁹

Normally, the stratum corneum constantly renews itself and efficiently repairs itself with routine wear and tear. With aging, there is a reduction in the synthesis of skin barrier proteins such as keratin, filaggrin, and involucrin.³⁰ Filaggrin is especially important. Breakdown of filaggrin into the stratum corneum forms natural moisturizing factor (NMF), which comprises 20%–30% of the stratum corneum's total dry weight.²⁹ NMF is a humectant, allowing for stratum corneum to bind water. NMF levels significantly decline with age, which corresponds to the drier skin observed in the elderly population.³¹ With aging, the sum of reduced synthesis of stratum corneum proteins and reduction of NMF result in a compromised skin barrier function and *trans*-epidermal water loss (TEWL), respectively.

There have been several studies showing that niacinamide can increase the biosynthesis of ceramides and other intercellular lipids in the stratum corneum, including free fatty acids and cholesterol. An *in vitro* study by Tanno et al.³² showed that when niacinamide was added to human keratinocyte cultures, ceramide synthesis was increased in a dose-dependent manner. Other intercellular lipids in the stratum corneum, such as free fatty acids, cholesterol, glycosylceramide, and sphingomyelin, were also increased. The specific mechanism was elucidated by measuring the effect of niacinamide on the activity of serine palmitoyltransferase (SPT) activity, the rate-limiting enzyme in the synthesis of sphingolipids; incubation of keratinocytes with niacinamide significantly increased the activity of SPT compared with control.

In an *in vivo* study by Tanno et al.,³² 2% niacinamide was topically applied twice daily for four weeks on volunteers with dry skin (n = 12). Levels of ceramides, free fatty acids, and cholesterol were quantified, which revealed significantly increased levels of ceramide and free fatty acids in the stratum corneum compared with vehicle. TEWL was also measured after four weeks of treatment, which showed that skin treated with topical 2% niacinamide showed significantly lower loss when compared with vehicle. The level of ceramides in the stratum corneum was directly correlated with TEWL, indicating that higher levels of ceramides prevented water loss from the stratum corneum and an improvement of the epidermal barrier.

In a clinical study by Draelos et al.,³³ a moisturizer containing 2% niacinamide was applied topically to one forearm twice daily for four weeks (n = 50, healthy women with median age of 45 years). This was a controlled, randomized, investigator-blinded study. At the end of four weeks, TEWL was significantly

lower for the forearms treated with the niacinamide-containing moisturizer compared to the untreated forearms, showing that application of a moisturizer-containing niacinamide improved the stratum corneum barrier function. Additionally, stratum corneum hydration was measured by skin capacitance; at the end of four weeks, forearms treated with the niacinamide-containing moisturizer were significantly more hydrated compared with control. This formulation was well tolerated.

Inflammatory Dermatoses

Epidermal barrier dysfunction can exacerbate inflammatory dermatoses such as atopic dermatitis, rosacea, and psoriasis.²¹ This is especially evident when variations in the humidity of the environment occur during the winter and in arid climates. As reviewed before, low humidity impairs normal epidermal barrier function and can worsen these inflammatory dermatoses. Pro-inflammatory cytokine IL-1 α , which is pre-formed within human keratinocytes, is released immediately when the skin barrier is disrupted. IL-1 α in turn upregulates the release of other pro-inflammatory cytokines such as intercellular adhesion molecule-1 (ICAM-1), IL-6, IL-8, and granulocyte colony-stimulating factor, causing further inflammation of the skin.^{34,35} It has also been shown that free radicals play a role in inflammatory dermatoses.³⁶ As previously mentioned, NADH, the reduced form of niacinamide, acts as an antioxidant and can protect cells and membranes from damage by free radicals.³⁷

In the clinical study by Draelos et al., mentioned earlier,³³ the effect of the moisturizer containing 2% niacinamide on facial erythema was assessed, utilizing the investigator global assessment of rosacea. After two weeks of twice-daily application, 79.2% of subjects showed global improvement; at the end of the four-week study, 95.7% of patients showed global improvement. This moisturizer did not change the appearance of telangiectasias, but there was a significant decrease in erythema severity, improvement of dryness, less scaling and peeling, and decreased numbers of inflammatory lesions. Most of the subjects in this study perceive a significant improvement in their appearance and facial skin condition at the endpoint. This topical formulation was well tolerated.

A clinical case series by Woźniacka et al.,³⁸ showed that topical 1% NADH in a petrolatum base was very effective in treating rosacea and atopic dermatitis. Ten subjects with rosacea and nine subjects with atopic dermatitis were treated with twice-daily application of topical 1% NADH. After two weeks of treatment, a majority of subjects with rosacea noted significant improvement, where a majority of papules were flattened and erythema was greatly reduced. In the patients with atopic dermatitis, symptoms of pruritus were markedly decreased or completely gone; erythema, dryness, vesicular lesions, and swelling were also significantly decreased. This formulation was well tolerated and no adverse effects were observed.

Acne

Acne vulgaris is one of the most common dermatological complaints and can be seen in all ages ranging from the first year of life into adulthood. It is a multifactorial disease in which genetics, hormonal changes, and bacteria can play a pathogenic role. *Propionibacterium acnes* induces inflammation by increasing neutrophils and pro-inflammatory cytokines. The first-line treatments include oral and topical antibiotics, which are often combined with comedolytic agents such as topical salicylic acid or retinoids. However, there has been growing concern for the increasing resistance of *P. acnes* to multiple antibiotics.^{39–41} This has encouraged the development of alternative therapies, such as benzoyl peroxide (BP), which are efficacious and yet do not present the problem of bacterial resistance. However, BP often causes dryness and irritation of the skin.

Niacinamide has shown effectiveness as an anti-inflammatory as well as assisting in epidermal barrier repair, as discussed earlier. These properties, as well as avoidance of bacterial resistance, would make niacinamide an excellent topical acne treatment.

There are several mechanisms of action that make niacinamide a useful treatment for acne. Its anti-inflammatory activity may possibly result from inhibition of neutrophil chemotaxis and secretion of subsequent pro-inflammatory cytokines.⁴² *P. acnes* activates the secretion of pro-inflammatory cytokine IL-8 by interacting with Toll-like receptor 2 (TLR-2) on the surface of keratinocytes. An *in vitro*

experiment by Grange et al. showed that incubation of immortalized human keratinocytes (HaCaT) and primary human keratinocytes with nicotinamide in the presence of *P. acnes* significantly decreased IL-8 production in a dose-dependent manner through the NF-kappaB and MAPK pathways.⁴³

In a double-blind study by Shalita et al., topical nicotinamide 4% gel or clindamycin 1% gel was applied twice daily to the face for 12 weeks in patients with moderate inflammatory acne (n = 76). This study showed that topical nicotinamide 4% gel was more efficacious as clindamycin 1% gel; 82% of the patients treated with nicotinamide gel and 68% of patients treated with clindamycin gel were considered improved.

In a similar study, Dos et al. compared the efficacy of clindamycin 1% gel and a combination clindamycin 1% gel plus nicotinamide 4% gel for the treatment of moderate acne. In this double-blind study, 80 patients were randomly assigned to apply either gel to their face twice daily for eight weeks. There was no significant difference in efficacy between the two groups.⁴⁴ Sardesai and Kambli,⁴⁵ demonstrated similar results in a study with 75 patients with inflammatory acne who received combination treatment with either nicotinamide 4% or clindamycin 1% versus clindamycin 1% alone. Of note, in a similar study by Khodaeiani et al.,⁴⁶ (n = 80), nicotinamide and clindamycin gels were significantly more efficacious in oily and non-oily skin types, respectively.

Reduction in Hyperpigmentation

Facial hyperpigmentation is multifactorial. Irregular hyperpigmentation can be caused by post-inflammatory hyperpigmentation, in which there is increased melanin production and/or transfer of melanin to keratinocytes as a result of an inflammatory dermatosis or irritation. Melasma presents as symmetric hyperpigmented patches and is most common among young to middle-aged women of darker skin types (Fitz IV–VI). Melasma is also caused by increased amounts of melanin, produced by hyperfunctional melanocytes in response to exacerbating factors such as sun exposure, use of oral contraceptives or other medications, and pregnancy.⁴⁷ Irregular facial hyperpigmentation can be psychosocially distressing.

Niacinamide may reduce hyperpigmentation through various mechanisms. In an *in vitro* study by Greatens et al.,⁴⁸ incubation of human keratinocytes with 10 μM of niacinamide inhibited melanosome transfer from melanocytes to keratinocytes in a dose-dependent manner. Viability assays showed that niacinamide was well tolerated by keratinocytes while in co-culture and did not negatively affect cell viability.

In a clinical study by Greatens et al.,⁴⁸ the dose-dependent and reversibility topical niacinamide was assessed. A double-blinded, randomized, vehicle-controlled, split-face clinical study included 79 women aged 28–54 years with brown hyperpigmentation (including but not limited to melasma, lentigines, and freckles) on the face bilaterally. Topical 5% or 2% niacinamide in a moisturizer base versus control was applied twice daily in a split-face protocol for eight weeks. For the group treated with topical 5% niacinamide, an additional 34 weeks of follow-up was assessed to determine reversibility of the lightening effect. Digital imaging and computer analysis was performed to evaluate results. Only topical 5% niacinamide demonstrated a significant reduction in hyperpigmentation at the end of eight weeks. After a follow-up period of 34 weeks, the hyperpigmentation regressed back to baseline. This formulation was well tolerated by the subjects and did not cause any adverse effects.

Wound Healing

Topical nicotinamide may be useful for improving wound healing. Several studies have shown niacinamide to be angiogenic.⁴⁹ Angiogenesis plays an essential role in the process of wound healing as well as normal physiologic functions and growth. In particular, thermal injury damages local microcirculation, which may prevent oxygen and nutrients from reaching the skin surface.⁵⁰ Additionally, local tissue damage and inflammation are associated with production of reactive oxygen species and toxic metabolites, resulting in oxidative damage of cellular membranes, lipid peroxidation, and further tissue injury.^{51,52} Agents that encourage angiogenesis and provide an antioxidant function, such as niacinamide, may aid in wound healing.

In a thermal injury model, Smith et al.,⁵³ showed that daily intraperitoneal nicotinamide treatments accelerated wound healing and increased capillary density.⁵³ Thermal injuries were created on the backs

TABLE 13.1

Commercial Products Containing Niacinamide

Manufacturer	Name	Other Featured Ingredients	Other Ingredients	Skin Type/Usage
CeraVe	Facial Moisturizing Lotion AM and PM	Ceramides, HA. AM lotion contains zinc oxide, homosalate, octinoxate, octocrylene	Cholesterol	All skin types
Cetaphil	Restoraderm Skin Restoring Moisturizer	Vitamin, allantoin, citric acid, ceramides	Shea butter, sunflower seed oil, arginine	Dry, eczema-prone skin
Clarisonic	Opal Sonic Infusion System	Anti-aging sea serum (extracts of algae, <i>Skeletonema costatum</i> , plankton, <i>Laminaria saccharina</i>) glycosaminoglycans, oat kernel extract, vitamin E, HA	Extracts of <i>Epilobium angustifolium</i> , <i>Kigelia africana</i> fruit, saccharomyces, ginger root, <i>Opuntia cocchinellifera</i> fruit	Eye area hydration, de-puffing
DDF	Clarifying Hydrator	Clarifying neutralizing complex (oil-absorbing micronized particles), vitamin E	Extracts of witch hazel, calendula, ginger root, <i>aloe barbadensis</i>	Acne; hydration
Elta MD	AM and PM Therapy Facial Moisturizer	Caffeine	Extracts of willow bark and <i>Piptadenia colubrine</i> peel	All skin types
epionce	Intense Defense Anti-Aging and Repair Serum	HA, vitamin E	Oils of palm, cottonseed, linseed, raspberry, extracts of Spanish needle and achiote	Dyschromia, anti-aging
Glytone	Neopeptide Hair Lotion Spray	Vitamin B3	Spearmint leaf oil, extracts of <i>Ruscus aculeatus</i> and artemia	Hair growth
iS Clinical	Poly-Vitamin Serum	Green tea polyphenols, retinol, HA, vitamin E	Zinc, extracts of sugar cane and bilberry	Dry/sensitive skin; anti-aging, skin tone improvement
La Roche Posay	Rosaliac Anti-Redness Moisturizer	Caffeine, vitamin E, shea butter	Palmitic acid	Redness reduction
La Roche Posay	Lipikar Balm AP	Shea butter	<i>Brassica campestris oleifera</i> oil, rapeseed oil	Severely dry/irritated skin, atopic dermatitis
MD Formulations	Vit-A-Plus Intensive Anti-Aging Serum	Retinyl palmitate, glycolic acid, 20% glycolic compound, vitamin A and E	Inositol, lactic acid, citric acid	Photoaged skin; anti-aging, resurfacing
MD Forte	Skin Rejuvenation Lotion I, II, III	Retinol, retinyl palmitate, glycolic acid compound (I-5%; II-20%; III-30%), vitamins A and E	Soybean oil	Anti-aging
Olay	Regenerist Daily Regenerating Serum	Palmitoyl pentapeptide-3, carnosine, green tea extract, vitamins B5 and E, amino-peptide	Dimethicone, allantoin	Anti-aging
Olay	Regenerist Microdermabrasion	Vitamins C and E	Silica	Resurfacing, skin tone improvement, anti-aging

(Continued)

TABLE 13.1 (Continued)

Commercial Products Containing Niacinamide

Manufacturer	Name	Other Featured Ingredients	Other Ingredients	Skin Type/Usage
PCA SKIN	Hydrating serum	<i>Aloe barbadensis</i> leaf juice, HA, wheat amino acids and extract of wheat germ	Urea, extracts of <i>Symphytum officinale</i> leaf, <i>Saccharomyces lysate</i> , inositol	Dry skin
PCA SKIN	Pigment Bar	Kojic acid, azelaic acid, <i>Aloe barbadensis</i> leaf juice	Tannic acid, witch hazel water, rosewood oil, vegetable oil, sorbitol	Hyperpigmentation, anti-inflammatory
PCA SKIN	SKIN ReBalance	Vitamin E, HA, <i>Aloe barbadensis</i> leaf juice	<i>Borago officinalis</i> seed oil, evening primrose oil	Normal to oily skin, post-procedure skin; redness reducer
philosophy	Clear Days Ahead Overnight Repair salicylic acid acne treatment pads	Glycolic acid, mandelic acid, vitamin E	Arginine, extracts of orange peel, <i>Tamarindus indica</i> , lentil seed	Acne; resurfacing
SkinMedica	LYTERA Skin Brightening Complex	Retinol, vitamin E	Squalene, extracts of licorice and <i>Dunaliella salina</i>	Hyperpigmentation, acne scarring, increasing radiance
SkinMedica	Redness Relief CalmPlex	4-ethoxybenaldehyde (CalmPlex™)	Squalene, jojoba seed oil	Redness reduction
SkinMedica	Retinol Complex 0.25, 0.5, 1.0	Retinol, vitamin E, ceramides	Squalene, extracts of <i>Dunaliella salina</i> , <i>Magnolia grandiflora</i> , <i>Oryza sativa</i> bran	Anti-aging, antioxidant
VivantSkincare	15% Mandelic Acid 3-in-1 Serum	Mandelic acid, lactic acid, urea	Inositol, fructose	Hyperpigmentation, anti-aging
VivantSkincare	Daily Repair Pads	Mandelic acid, salicylic acid, sodium lactate, urea, lactic acid	Saccharomyces/zinc ferment, inositol	Hyperpigmentation, anti-aging, skin-repairing
VivantSkincare	Derm-A-Renew Gentle Peptide and Vitamin A	Retinyl propionate, N-hydroxycuccinimide, chrysin, palmitoyl tetrapeptide-7, kojic acid, lactic acid	Inositol, fructose	Acne; anti-aging
VivantSkincare	Exfol-A Forte	Glycolic acid, retinyl propionate, salicylic acid, kojic acid, citric acid, sodium lactate, urea, lactic acid	Inositol, fructose	Acne, oily skin; hyperpigmentation, anti-aging
VivantSkincare	Rejuv Rx	N-hydroxysuccinimide, chrysin, urea, lactic acid, palmitoyl tetrapeptide-7	Inositol, fructose	Redness reduction, anti-aging

Note: HA = hyaluronic acid.

of male rats, and then the animals were treated with 50 mg nicotinamide or saline twice daily for 21 days. Biopsies were then taken from the skin. Significant increases in capillary density were noted in the injured skin of rats treated with nicotinamide versus those treated with saline. Additionally, healing occurred at a significantly faster rate with systemic nicotinamide versus saline, as evaluated by planimetric evaluation of the granulation bed and eschar.

Nicotinamide has been investigated for use in postoperative healing of reconstructive surgical wounds. Collins et al., showed that systemic nicotinamide improved wound healing in a random island pedicle flap model.⁵⁴ A large 7 × 7 cm island pedicle flap was created on male mice (n = 50); the animals received either 0.6 cc of saline or increasing doses of nicotinamide (ranging from 25 mg twice daily to 200 mg twice daily) for 16 days. The rate of flap survival was significantly highest for the groups treated with nicotinamide, with the highest survival rate of 86% in the group treated with nicotinamide 200 mg twice daily, compared with 58.8% survival in the saline-only group. The same group performed a similar experiment and added hyperbaric oxygen, which significantly increased flap survival to over 90%.⁵⁵ There have been other studies supporting the use of nicotinamide for increasing the viability of flaps and acceleration of wound healing.⁵⁶

There are other proposed mechanisms for how niacinamide may improve wound healing, including effects on fibroblast collagen synthesis, cellular migration, and cellular proliferation. In an *in vitro* experiment by Wessels et al.,⁵⁷ a niacinamide-dominated cosmeceutical formulation containing niacinamide 0.31 mg/mL, L-carnosine 0.10 mg/mL, hesperidin 0.05 mg/mL, and Biofactor HSP® (heat shock proteins) 5.18 µg/mL was utilized. Human dermal fibroblasts were incubated with the cosmeceutical formulation in varying concentrations for 24 hours. The results showed that dermal fibroblast proliferation and collagen production was significantly higher versus control at a dilution of 1:100. A wound closure test (scratch assay) showed that confluence of dermal fibroblasts reached 99.6% after 24 hours incubation versus 61.1% in the control group. This study demonstrated promising results supporting the use of niacinamide for wound healing. Further studies are warranted.

Commercially Available Products

See [Table 13.1](#).

Conclusion

Niacinamide is a popular ingredient in topical cosmeceutical formulations for its many well-documented effects on skin. It is able to repair the epidermal barrier by increasing synthesis of keratin and ceramides, increasing cell turnover, and therefore improving skin function. Niacinamide has also shown a variety of other benefits in the treatment of acne and inflammatory dermatoses, and may also improve wound healing. Further research must be performed to discover the full potential of niacinamide as a cosmeceutical.

REFERENCES

1. Elvehjem CA, Madden RJ, Strong FM, Woolley DW. The isolation and identification of anti-black tongue factor. *J Biol Chem* 1938;132(1):137–49.
2. Weidel H. Zur Kenntniss des Nicotins. *Justus Liebig's Annalen der Chemie und Pharmacie* 1873;165(2):330–49.
3. Otte N, Borelli C, Korting HC. Nicotinamide—Biologic actions of an emerging cosmetic ingredient. *Int J Cosmet Sci* 2005;27(5):255–61.
4. Pique-Duran E, Perez-Cejudo JA, Comeselle D, Palacios-Llopis S, Garcia-Vazquez O. Pellagra: A clinical, histopathological, and epidemiological study of 7 cases. *Actas Dermosifiliogr* 2012;103(1):51–8.
5. Bologna J, Jorizzo JL, Schaffer JV. *Dermatology*. 3rd edition. Philadelphia: Elsevier Saunders; 2012.
6. Julius U, Fischer S. Nicotinic acid as a lipid-modifying drug—A review. *Atheroscler Suppl* 2013;14(1):7–13.

7. Ungerstedt JS, Blombäck M, Söderström T. Nicotinamide is a potent inhibitor of proinflammatory cytokines. *Clin Exp Immunol* 2003;131(1):48–52.
8. Namazi MR. Nicotinamide: A potential addition to the anti-psoriatic weaponry. *Faseb J* 2003;17(11):1377–9.
9. Fivenson DP, Breneman DL, Rosen GB, Hersh CS, Cardone S, Mutasim D. Nicotinamide and tetracycline therapy of bullous pemphigoid. *Arch Dermatol* 1994;130(6):753–8.
10. Tutrone WD, Spann CT, Scheinfeld N, Deleo VA. Polymorphic light eruption. *Dermatol Ther* 2003;16(1):28–39.
11. Dyer DG, Dunn JA, Thorpe SR et al. Accumulation of Maillard reaction products in skin collagen in diabetes and aging. *J Clin Invest* 1993;91(6):2463–9.
12. Wu JT. Advanced glycosylation end products: A new disease marker for diabetes and aging. *J Clin Lab Anal* 1993;7(5):252–5.
13. Crisan M, Taulescu M, Crisan D et al. Expression of advanced glycation end-products on sun-exposed and non-exposed cutaneous sites during the ageing process in humans. *PLoS One* 2013;8(10):0075003.
14. Wilson SL, Guilbert M, Sule-Suso J et al. A microscopic and macroscopic study of aging collagen on its molecular structure, mechanical properties, and cellular response. *Faseb J* 2014;28(1):14–25.
15. Pageon H, Zucchi H, Rousset F, Monnier VM, Asselineau D. Skin aging by glycation: Lessons from the reconstructed skin model. *Clin Chem Lab Med* 2014;52(1):169–74.
16. Bissett DL, Oblong JE, Berge CA. Niacinamide: A B vitamin that improves aging facial skin appearance. *Dermatol Surg* 2005;31:860–6.
17. Bos DC, de Ranitz-Greven WL, de Valk HW. Advanced glycation end products, measured as skin autofluorescence and diabetes complications: A systematic review. *Diabetes Technol Ther* 2011;13(7):773–9.
18. Al L. *Vitamins and Coenzymes*. New York, NY: Worth Publishers; 1975.
19. Bissett DL, Miyamoto K, Sun P, Li J, Berge CA. Topical niacinamide reduces yellowing, wrinkling, red blotchiness, and hyperpigmented spots in aging facial skin. *Int J Cosmet Sci* 2004;26(5):231–8.
20. Denda M, Sato J, Tsuchiya T, Elias PM, Feingold KR. Low humidity stimulates epidermal DNA synthesis and amplifies the hyperproliferative response to barrier disruption. *Implication Season Exacerb Inflamm Dermatoses* 1998;111(5):873–8.
21. Wilkinson JD, Rycroft RJG. Contact dermatitis. In: Burton JL, Ebling FJ, Champion RH, eds, *Textbook of Dermatology*, 5th edition. Oxford: Blackwell Scientific Publications; 1992.
22. Cohen-Mansfield J, Jensen B. The preference and importance of bathing, toileting and mouth care habits in older persons. *Gerontology* 2005;51(6):375–85.
23. Beltrani VS. Occupational dermatoses. *Ann Allergy, Asthma Immunol*. 1999;83(6 Pt 2):607–13.
24. Menon GK, Ghadially R, Williams ML, Elias PM. Lamellar bodies as delivery systems of hydrolytic enzymes: Implications for normal and abnormal desquamation. *Br J Dermatol* 1992;126(4):337–45.
25. Downing DT. Lipid and protein structures in the permeability barrier of mammalian epidermis. *J Lipid Res* 1992;33(3):301–13.
26. Popa I, Remoue N, Osta B et al. The lipid alterations in the stratum corneum of dogs with atopic dermatitis are alleviated by topical application of a sphingolipid-containing emulsion. *Clin Exp Dermatol* 2012;23(10):1365–2230.
27. Yamamoto A, Serizawa S, Ito M, Sato Y. Stratum corneum lipid abnormalities in atopic dermatitis. *Arch Dermatol Res* 1991;283(4):219–23.
28. Imokawa G, Abe A, Jin K, Higaki Y, Kawashima M, Hidano A. Decreased level of ceramides in stratum corneum of atopic dermatitis: An etiologic factor in atopic dry skin? *J Invest Dermatol* 1991;96(4):523–6.
29. Rawlings A, Harding C, Watkinson A, Banks J, Ackerman C, Sabin R. The effect of glycerol and humidity on desmosome degradation in stratum corneum. *Arch Dermatol Res* 1995;287(5):457–64.
30. Gehring W. Nicotinic acid/niacinamide and the skin. *J Cosmetic Dermatol* 2004;3(2):88–93.
31. White-Chu EF, Reddy M. Dry skin in the elderly: Complexities of a common problem. *Clin Dermatol* 2011;29(1):37–42.
32. Tanno O, Ota Y, Kitamura N, Katsube T, Inoue S. Nicotinamide increases biosynthesis of ceramides as well as other stratum corneum lipids to improve the epidermal permeability barrier. *Br J Dermatol* 2000;143(3):524–31.
33. Draelos ZD, Ertel K, Berge C, Amburgey M. Niacinamide-containing facial moisturizer improves skin barrier and benefits subjects with rosacea. *CUTIS—New York* 2005;76(2):135.

34. Wood LC, Jackson SM, Elias PM, Grunfeld C, Feingold KR. Cutaneous barrier perturbation stimulates cytokine production in the epidermis of mice. *J Clin Invest* 1992;90(2):482–7.
35. Barker JN, Mitra RS, Griffiths CE, Dixit VM, Nickoloff BJ. Keratinocytes as initiators of inflammation. *Lancet* 1991;337(8735):211–4.
36. Maccarrone M, Catani MV, Iraci S, Melino G, Agrò AF. A survey of reactive oxygen species and their role in dermatology. *J Eur Acad Dermatol Venereol* 1997;8(3):185–202.
37. Halliwell B, Gutteridge JM. Role of free radicals and catalytic metal ions in human disease: An overview. *Methods Enzymol* 1990;186:1–85.
38. Woźniacka A, Sysa-Jędrzejowska A, Adamus J, Gębicki J. Topical application of NADH for the treatment of rosacea and contact dermatitis. *Clin Exp Dermatol* 2003;28(1):61–3.
39. Nakase K, Nakaminami H, Noguchi N, Nishijima S, Sasatsu M. First report of high levels of clindamycin-resistant *Propionibacterium acnes* carrying erm(X) in Japanese patients with acne vulgaris. *J Dermatol* 2012;39(9):794–6.
40. Eady EA, Gloor M, Leyden JJ. *Propionibacterium acnes* resistance: A worldwide problem. *Dermatology* 2003;206(1):54–6.
41. Cooper AJ. Systematic review of *Propionibacterium acnes* resistance to systemic antibiotics. *Med J Aust* 1998;169(5):259–61.
42. Sivapirabu G, Yiasemides E, Halliday GM, Park J, Damian DL. Topical nicotinamide modulates cellular energy metabolism and provides broad-spectrum protection against ultraviolet radiation-induced immunosuppression in humans. *Br J Dermatol* 2009;161(6):1357–64.
43. Grange PA, Raingeaud J, Calvez V, Dupin N. Nicotinamide inhibits *Propionibacterium acnes*-induced IL-8 production in keratinocytes through the NF-kappaB and MAPK pathways. *J Dermatol Sci* 2009;56(2):106–12.
44. Dos SK, Barbhuiya JN, Jana S, Dey SK. Comparative evaluation of clindamycin phosphate 1% and clindamycin phosphate 1% with nicotinamide gel 4% in the treatment of acne vulgaris. *Indian J Dermatol Venereol Leprol* 2003;69(1):8–9.
45. Sardesai VR, Kambli VM. Comparison of efficacy of topical clindamycin and nicotinamide combination with plain clindamycin for the treatment of acne vulgaris and acne resistant to topical antibiotics. *Indian J Dermatol Venereol Leprol* 2003;69(2):138–9.
46. Khodaeiani E, Fouladi RF, Amirnia M, Saeidi M, Karimi ER. Topical 4% nicotinamide vs. 1% clindamycin in moderate inflammatory acne vulgaris. *Int J Dermatol* 2013;52(8):999–1004.
47. Grimes PE, Yamada N, Bhawan J. Light microscopic, immunohistochemical, and ultrastructural alterations in patients with melasma. *Am J Dermatopathol* 2005;27(2):96–101.
48. Greatens A, Hakozaki T, Koshoffer A et al. Effective inhibition of melanosome transfer to keratinocytes by lectins and niacinamide is reversible. *Exp Dermatol* 2005;14(7):498–508.
49. Kull FC, Jr., Brent DA, Parikh I, Cuatrecasas P. Chemical identification of a tumor-derived angiogenic factor. *Science* 1987;236(4803):843–5.
50. Nassar MA, Eldien HM, Tawab HS et al. Time-dependent morphological and biochemical changes following cutaneous thermal burn injury and their modulation by copper nicotinate complex: An animal model. *Ultrastruct Pathol* 2012;36(5):343–55.
51. Cetinkale O, Belce A, Konukoglu D, Senyuva C, Gumustas MK, Tas T. Evaluation of lipid peroxidation and total antioxidant status in plasma of rats following thermal injury. *Burns* 1997;23(2):114–6.
52. Horton JW. Free radicals and lipid peroxidation mediated injury in burn trauma: The role of antioxidant therapy. *Toxicol* 2003;189(1–2):75–88.
53. Smith YR, Klitzman B, Ellis MN, Kull FC, Jr. The effect of nicotinamide on microvascular density and thermal injury in rats. *J Surg Res* 1989;47(5):465–9.
54. Collins TM, Denish A, Sheffield J, Mitra A, Stueber K, Smith YR. Nicotinamide enhances skin flap survival. *Scand J Plast Reconstr Surg Hand Surg* 1989;23(3):177–9.
55. Collins TM, Caimi R, Lynch PR et al. The effects of nicotinamide and hyperbaric oxygen on skin flap survival. *Scand J Plast Reconstr Surg Hand Surg* 1991;25(1):5–7.
56. Im MJ, Hoopes JE. Improved skin flap survival with nicotinic acid and nicotinamide in rats. *J Surg Res* 1989;47(5):453–5.
57. Wessels Q, Pretorius E, Smith CM, Nel H. The potential of a niacinamide dominated cosmeceutical formulation on fibroblast activity and wound healing *in vitro*. *Int Wound J* 2014;11(2):152–8.

14

Anti-Aging Topical Peptides and Proteins

Fakhra Khalid, Farzam Gorouhi, and Howard I. Maibach

Introduction

Since skin projects socially valuable attributes such as status, wealth, sexuality, and age, the demand for younger-looking skin in older age is a reality for a growing sector of our society. Between 2000 and 2050, the percentage of elderly American citizens is expected to increase from 12% to 21%. The “baby boomers” cohort of 76 million people will make up a significant portion of the population during this time.¹ Although safe and effective anti-aging skin care may be targeted towards the elderly, concern over aging skin is not limited to this population. Psychosocial complications due to aging skin, including social anxiety, depression, and isolation, are also observed in much younger people.² In one study, more than 50% of women under 30 years old reported dissatisfaction with age-related changes in skin, including bags under their eyes, freckles, patchy hyperpigmentation, and fine wrinkles.² This suggests that people of various ages may seek anti-aging treatments to improve self-esteem and enhance social relations. Pharmaceutical companies have produced creams and other materials to assist in cutaneous rejuvenation. These cosmetic interventions often include topical peptides and proteins as drugs to target wrinkles, firm skin, and reverse the effects of solar and natural aging of skin.

Biology of Aging Skin

The pathophysiologic basis of skin aging is related to the cellular accumulation of reactive oxygen species, which damage lipid membranes, enzymes, and DNA. Skin cells become increasingly senescent, and cell regeneration in the epidermis slows down. The microanatomy of aged skin shows that it is inelastic and sagging, with an increasingly rough and wrinkly texture. Other structural abnormalities include puffiness around the eyes, erythema, hyperpigmentation, and yellowing of the skin. Histological signs include epithelial thinning, flattening of the dermal-epithelial junction, decreased collagen fiber density, and loss of melanocytes and Langerhans cells. In the dermal layer, aged skin has a reduced population of fibroblasts and more spaced sebaceous glands. The synthesis of hydroxyproline, a major structural component of collagen, is also decreased in aged skin. Skin wound healing ability may also be compromised due to loss of skin integrity and capillary density in dermal microvasculature.

In the skin, the extracellular matrix is composed mainly of Type I collagen fibrils. The process of fibrillogenesis, or collagen synthesis, occurs at the dermal layer in fibroblasts. These cells synthesize and release the triple helix procollagen with loose ends. Extracellular enzymes remove the ends, creating tropocollagen, subsequently organized into collagen fibrils. The fibrils are finally wound together to form cable-like structures that can be several micrometers in diameter. Decorin, a collagen stabilizing proteoglycan in the extracellular matrix (ECM), is commonly found as a catabolic fragment, decorunt, in aged skin. This may affect skin elasticity and collagen fiber density in the skin.³

One environmental factor that can hasten the skin’s aging process is dermal photodamage by ultraviolet (UV) light. UVA and UVB irradiation activates mitogen-activated protein kinase (MAPK), which leads to the production of transcription factor AP-1 and results in higher levels of reactive oxygen species in the cell. AP-1, in turn, enhances the expression of matrix metalloproteinases (MMP), a family of zinc-dependent endopeptidases. MMP-1, MMP-3, and MMP-9 are involved with skin aging due to

degradation of the epidermal basement membrane and extracellular matrix proteins (EMPs) such as collagen and glycosaminoglycans (GAGs).⁴ Photoaging can also be induced by increased inflammation. UVB irradiated keratinocytes increase expression of pro-inflammatory cytokines such as tumor necrosis factor α , interleukins 1α , 1β , and 6, as well as the prostaglandin PGE_2 . This results in degradation of EMPs skin aging.⁵

Certain personal characteristics, such as the degree of UV sun exposure, endocrine abnormalities, chronic diseases, alcohol use, smoking, infections, and genodermatoses, can also potentiate age-related skin damage. By targeting the cellular basis of these harmful developments, active ingredients of topical peptides help alleviate some of the effects of skin aging from natural and environmental causes.

Topical Cosmeceuticals and Skin Permeability

Transdermal penetration is an important consideration in the measurement of a topical peptide's therapeutic usefulness. The outermost layer of the epidermis, the stratum corneum (SC), serves as the first and primary barrier for skin permeation by drugs. A recent study found that removal of the SC significantly improved permeability of large proteins such as bovine serum albumin and insulin *in vitro* in human skin. However, it was also concluded that the viable epidermis provides a comparable rate-limiting barrier to the transdermal permeability of topical drugs.⁶

A negatively charged tissue, the SC pH ranges from 5 to 6 and it is bound together by tight junctions. The SC is made up of dead corneocytes surrounded by an intercellular lipid layer, and in total is comprised of 60% structural proteins, 15% water, and 25% lipids. The extracellular lipid system contains 50% ceramides, 25% cholesterol, 15% glucosylceramide, and 10% free fatty acids, forming a protective barrier to maintain skin hydration.⁷ Sebum, organic acids, antioxidants, glycerol, GAGs, and inorganic ions are also present at the surface. Proteolytic enzymes and the skin's bacterial flora support this barrier. They limit transdermal penetration by degrading topical peptides.

Covalent bonds between ceramides and structural proteins on corneocyte membranes are impermeable by peptides and proteins. Nevertheless, the SC offers three methods of permeation for topical drugs: intercellular, transcellular, and transappendageal.⁸ Intercellular penetration involves sinuous openings between lipids no larger than $0.013\ \mu\text{m}$ and is the major method of topical peptide permeation.⁷ In contrast, transcellular transport is least likely since it involves permeation through keratinized corneocytes. Transappendageal transport occurs at sweat glands or hair follicles and their associated sebaceous glands. This type of permeation is supported by surfactants and glycols. Like the SC, skin permeability varies on different parts of the body. Hydrophobic substances are more permeable in skin with higher lipid content, such as the face, while hydrophilic substances permeate more readily in the palms and soles of feet, which contain a relatively lower amount of lipids. Overall, aged skin contains fewer lipids. Therefore, in aged persons topical peptides may be more efficacious than in younger populations.⁹ It is important to note that while not all anti-aging cosmetics must penetrate the SC layer, the discussion in this chapter is focused on peptide and protein cosmeceuticals that permeate skin transdermally to modulate skin remodeling, activate cell proliferation, or confer structural changes to the skin by changing EMPs.

As a passive diffusion process, the permeation ability of peptides depends on its physiochemical properties, including pKa, molecular size, stability, binding affinity, water solubility, and partition coefficient. Permeation coefficient is a linear function of the partition coefficient if the diffusion rate stays unchanged. It is also dependent on the site, area, and duration of topical protein application, properties of any transdermal device used, and the creation of a local depot at the site of application. Lastly, permeation is affected by biological factors including age, the integrity of the skin, its thickness and its components, as well as the cutaneous metabolism.⁷ Diffusivity through the SC is dependent upon the number of hydrogen bonding groups present on the protein or peptide, where no hydrogen bonding is ideal and more than four hydrogen bonding groups bars permeation with diffusion alone.¹⁰ Some ideal parameters of topical protein are listed in [Table 14.1](#). Smaller nonpolar proteins or peptides, with a moderate log of partition coefficient of octanol/water, lower melting point, and lower aqueous solubility and hydrogen bonding are most permeable.^{11,12} The Potts and Guy equation, below, was established in 1992 to estimate

TABLE 14.1

Physical Properties Allowing Protein Permeation

Property	Ideal Range
Molecular weight	<500 Da
Log of partition coefficient of octanol/water	1–3
Melting point	<200°C
Aqueous solubility	>1 mg/mL
Polar centers	None or few
Hydrogen bonding groups	<4

Note: Smaller nonpolar proteins or peptides, with a moderate log of partition coefficient of octanol/water, lower melting point, and lower aqueous solubility and hydrogen bonding are most permeable.^{11,12}

the relative ability of a substance to penetrate skin, or its K_p . In this equation, $P_{(\text{octanol/water})}$ is the octanol/water partition coefficient and MW is the molecular weight of the peptide or protein.¹³

$$\text{Log } K_p = 0.71 \log P_{(\text{octanol/water})} - 0.0061(\text{MW}) - 2.74$$

Peptides and proteins have hydrogen bonding amide bonds, and are usually large, hydrophilic, and often charged at physiological pH, properties that limit their skin permeability. Therefore, chemical penetration enhancers such as iontophoresis, sonophoresis, chemical structural modification, and colloidal carrier systems are often used to enhance peptide dermal delivery methods.¹⁴

Covalent bonding of a peptide or protein to another peptide or long chain fatty acid, as well as complex formation with a metal such as copper (Cu), increases transdermal peptide delivery. One study reported successful use of a short synthetic peptide, ACSSSPSKHCG, to facilitate transdermal delivery of insulin.¹⁵ Another strategy for chemically enhanced penetration is the use of a fatty acid derivative of a polypeptide. For example, the palmitoyl derivative of interferon α (IFN α) penetrates skin fivefold in comparison to IFN α alone.¹⁶ Covalent bonding to a long chain fatty acid could help topical peptide proteolytic degradation, as in the case for pentapeptide-3, when it is covalently linked to palmitate.¹⁷ Other covalent modifications to peptides with pyrrolidones, DMSO, azone (1-dodecylazacycloheptan-2-one), urea, sugar esters, and surfactants have also increased transdermal delivery of peptide hormones.¹⁸ Complex formation with a metal ion can result in increased permeation as well. At physiological pH, the permeability coefficient, Kp (cm/s⁻¹), of most amino acids ranges from 3.61×10^{-9} of valine to arginine's 2.77×10^{-8} , which differs slightly for each amino acid at a more acidic pH.¹⁹ Kp of glycine improves from 1.05×10^{-8} to 1.62×10^{-6} when absorbed as Glycine-Cu. A similar trend of Kp improvement is observable in Cu complex formation with histidine, alanine, lysine, and valine.²⁰ Table 14.2 lists Kp values of amino acids and some short chain carrier peptides.

Colloidal drug carriers such as liposomes, nanospheres, and emulsions also assist in topical drug skin penetration.²¹ Different mechanisms for transdermal permeation using liposomal colloidal carriers have been proposed. These carriers could provide a localizing effect by improving drug deposition on the skin and limiting systemic absorption, targeted delivery to hair follicles, liposome vesicle adsorption in the SC, or by structurally altering the intercellular lipid network.⁸ An advantage to liposomal carriers is their ability to protect encapsulated proteins, deliver to many different cell types, and avoid skin toxicity, especially if they are made of naturally occurring epidermal lipids.¹⁷ However, other approaches to transdermal delivery are gaining popularity. For example, polyurethane, a polymer, has been used in emulsions to enhance transdermal delivery of topical peptides.²² Niosome carriers are also effective in penetration of the SC. In one study, olein vesicles were more effective than liposomes for percutaneous absorption of the antioxidant resveratrol.²³ Glyceromes, composed of phospholipids, glycerol, and water, are a new transdermal carrier device that also have improved skin deposition and permeability when compared to liposomes.²⁴ Not only are they more fluid than liposomes, glycerosomes extend the time of a drug in local and systemic circulations, and reduce phagocytic clearance of the drug.¹⁷ Even targeted

TABLE 14.2

Permeation Coefficients of Proteins and Carrier Oligopeptides

Peptide	Permeation Coefficient (cm · s ⁻¹)	Reference
GHK	1.36×10^{-9}	140
GHK-Cu	1.35×10^{-9}	140
GSH	8.63×10^{-10}	140
GSH-Cu	1.5×10^{-9}	140
Histidine	4.44×10^{-9} , pH = 7.6 5.55×10^{-9} , pH = 7.4	141
Histidine-Cu	$2.72 \times 10^{-6} \pm 0.05 \times 10^{-6}$	142
Alanine	1.03×10^{-8} , pH = 6.0 1.53×10^{-8} , pH = 7.4	141
Alanine-Cu	$1.90 \times 10^{-6} \pm 0.16 \times 10^{-6}$	142
Lysine	1.08×10^{-7} , pH = 9.8 5.83×10^{-9} , pH = 7.4	141
Lysine-Cu	$1.66 \times 10^{-6} \pm 0.07 \times 10^{-6}$	142
Glycine	3.30×10^{-8} , pH = 6.0 1.05×10^{-8} , pH = 7.4	141
Glycine-Cu	$1.62 \times 10^{-6} \pm 0.06 \times 10^{-6}$	142
Valine	1.25×10^{-8} , pH = 6.0 3.61×10^{-9} , pH = 7.4	141
Valine-Cu	$1.59 \times 10^{-6} \pm 0.07 \times 10^{-6}$	142
α -MSH (hisetal)	1.55×10^{-8}	143
α -MSH (hisetal)	2.58×10^{-9}	144
Methionine	4.72×10^{-9} , pH = 5.6 8.61×10^{-9} , pH = 7.4	141
Proline	9.16×10^{-9} , pH = 6.3 7.50×10^{-9} , pH = 7.4	141
Serine	1.00×10^{-8} , pH = 5.6 8.33×10^{-9} , pH = 7.4	141
Threonine	3.27×10^{-8} , pH = 6.2 3.61×10^{-9} , pH = 7.4	141
Isoleucine	1.44×10^{-8} , pH = 6.0 3.61×10^{-9} , pH = 7.4	141
Leucine	4.44×10^{-9} , pH = 6.0 8.05×10^{-9} , pH = 7.4	141
Asparagine	1.14×10^{-8} , pH = 5.4 9.72×10^{-9} , pH = 7.4	141
Asparatic acid	2.38×10^{-8} , pH = 2.8 2.22×10^{-9} , pH = 7.4	141
Glutamine	8.88×10^{-9} , pH = 5.6 1.39×10^{-8} , pH = 7.4	141
Glutamic acid	1.36×10^{-8} , pH = 7.4 2.78×10^{-9} , pH = 7.4	141
Phenylalanine	6.78×10^{-8} , pH = 5.4 8.33×10^{-9} , pH = 7.4	141
Arginine	9.05×10^{-8} , pH = 10.8 2.77×10^{-8} , pH = 7.4	141
Tyrosine	7.22×10^{-9} , pH = 5.6 4.44×10^{-9} , pH = 7.4	141
Tryptophan	5.28×10^{-9} , pH = 5.7 4.17×10^{-9} , pH = 7.4	141
Cysteine	9.44×10^{-9} , pH = 5.2 5.28×10^{-9} , pH = 7.4	141

Note: GHK: glycyl-L-histidyl-L-lysine; GSH: (2S)-2-amino-4-[(1R)-1-[(carboxymethyl)carbamoyl]-2-sulfanylethyl]carbamoyl]butanoic acid; MSH: melanocyte-stimulating hormones.

intracellular peptide delivery has been achieved by forming poly-(I/C) complexes with a peptide, which resulted in rapid internalization with minimal cellular toxicity.²⁵

While peptides may be altered chemically or carried in tiny vesicles through the SC to succeed in permeation, mechanical or electrical manipulation of the barrier could also aid in transdermal delivery. Iontophoresis uses small electric currents to pass charged peptides through skin. Peptide hormones such as insulin and thyrotropin releasing hormone have been absorbed in this way.²⁶ Microdermabrasion is another method to improve absorption of topical peptides for fine lines and wrinkles, since it removes some of the SC layers. In one study, photorejuvenation was achieved using microdermabrasion followed by ultrasonic application of topical drugs, including a peptide-containing complex.²⁷ Clearly, these techniques can be combined to enable efficient topical peptide or protein permeation through the SC.

Many SC models have been created to test the ability of topical peptides and permeability enhancing agents. Recently, a multi-well resistance chamber was found to be superior to Franz cell diffusion studies in assessing transdermal penetration ability and producing a reliable *Kp*.²⁸ The resistance chamber relies on the skin's intrinsic electrical resistance, is faster, and is able to operate at 37°C, better reflecting normal physiological conditions. Terahertz imaging, an alternate method of assessing the penetrative ability of topical drugs, is notable for its ability to measure the spatial distribution and depth of topical protein or peptide penetration over a specified amount of time.²⁹

Types of Topical Peptides

Topical peptides and proteins are classified into four categories: signal peptides, carrier peptides, enzyme inhibitor peptides, and neurotransmitter inhibitor peptides. A list of topical peptide and protein characteristics are presented in [Table 14.3](#). [Table 14.4](#) summarizes efficacy data on each drug.

Signal oligopeptides are commonly synthesized from portions of EMPs and from natural peptides in the environment that mimic these structural macromolecules. Also called matrikines, signal oligopeptides stimulate dermal fibroblasts to proliferate and alter their protein expression patterns. Their role is to boost fibrillogenesis and modulate the EMP landscape. Matrikines increase levels of collagen, elastin, proteoglycan, GAG, and fibronectin deposition to promote firmer and younger looking skin. The two most prevalent synthetic peptide sequences in this category are KTTKS (lysyl-threonyl-threonyl-lysyl-serine) and GHK (glycyl-L-histidyl-L-lysine), the former a short peptide segment of collagen and the latter a naturally occurring endogenous peptide. A shortened form of KTTTS, KT, has been shown to be an effective anti-aging peptide as well. Syn-Coll and Biopeptide-EL increase collagen synthesis by activating a growth factor. Tripeptide-10-Citrulline is a short peptide segment of decorin, a GAG most commonly found at wound healing sites. VGVAPG is a peptide fragment of elastin. Acetylpeptides AcTP-9 and AcTP-11 are new synthetic signal oligopeptides that increase the synthesis of lumican, a small leucine-rich proteoglycan, and syndecan-1, a transmembrane proteoglycan, respectively. Signal oligopeptides extracted or engineered from natural sources include Hexapeptide-11 synthesized from yeast fermentation, SECMA-1, extracted from green algae of *Ulva*, and aquaporin, extracted from *Ajuga turkestanica*. In summary, these signal oligopeptides reinforce collagen deposition through fibroblast stimulation and reconstruct the extracellular matrix integrity of dermal cells.

Carrier peptides are a subcategory of signal oligopeptides. Their major function is to pass through the SC and transduce dermal cells to deliver active ingredients such as copper and manganese. These metals are necessary for the enzymatic processes involved with wound healing and removal of reactive oxygen species, such as with superoxide dismutase. Carrier peptides discussed in this chapter include arginine rich-peptides, which are attracted to the SC's slightly negative charge, GHK, and PEP.

In addition to oligopeptides, endogenous and recombinant proteins such as cytokinins, growth factors, peptide hormones, and cytokines can also behave as signal peptides with anti-aging effects. Recombinant human growth hormone (hGH) and transforming growth factors (TNF) α and β modulate skin reconstruction through mitogenically activating keratinocytes and fibroblasts. Cytokinin-like proteins such as keratin and pyratine-6, in addition to the peptide hormone melatonin, reduce the aging effects of ROS in cells, amongst other functions. IFN can modulate the skin immune system to have an anti-inflammatory and anti-aging effect on the skin, while heat shock protein 70 (HSP70) and recombinant fusion protein

TABLE 14.3

Characteristics of Topical Peptides and Proteins Used as Cosmeceuticals

Peptides and Proteins	Alternate/Generic Names	Source	Peptide Type	Mechanism of Action	Cosmeceutical Uses
Copper tripeptide complex	Copper tripeptide-1 or GHK-Cu or Iamin®	Synthetic	Signal and carrier peptide	Promotes 1. Degradation of “extra-large” collagen aggregates—found in scars 2. Synthesis of more regular collagen—found in normal skin 3. Production of elastin, proteoglycans, glycosaminoglycans p 4. Growth and migration of different cell types 5. Anti-inflammatory responses 6. Anti-oxidant responses	Anti-aging, anti-wrinkle, after-sun products, after skin resurfacing, skin moisturizer, hair growth stimulator
Manganese tripeptide complex	Manganese tripeptide-1 or GHK-Mn	Synthetic	Signal and carrier peptide	Stimulates 1—matrix protein growth, 2—anti-oxidant responses, 3—manganese-superoxide dismutase pathway	Anti-aging, anti-wrinkle
Biopeptide-CL	Pal-GHK	Synthetic	Signal peptide	Stimulates collagen and glycosaminoglycans synthesis	Anti-aging, anti-wrinkle, antisolar, firming, skin moisturizer
Syn®-Coll	Palmitoyl tripeptide-3/5	Synthetic	Signal peptide	Mimics thrombospondin I tripeptide sequence and promotes collagen formation	Improves stretch marks, anti-wrinkle, skin moisturizer, improves skin’s firmness and tone
Biopeptide-EL	Hydroglycolic solution of Pal-Val-Gly Val-Val-Ala-Pro-Gly	Synthetic	Signal peptide	Up-regulates transforming growth factor-beta (TGF-β)	Firming peptide and eye contour product, anti-aging
Peptamide-6	FVAPFP or Phe-Val-Ala-Pro-Phe-Pro	Biotechnologic (<i>Saccharomyces</i> yeast fermentation)	Signal peptide	Increases collagen synthesis and upregulates transmembrane, matrix, and cell shock proteins and growth factors	Firming peptide ideal for all face/body/eye creams, anti-aging
Acetyl tetrapeptide-5	Eyeseryl®	Synthetic	Enzyme inhibitor peptide	Inhibits collagen glycation, increases dose-dependent vascular permeability, prevents liquid accumulation under the eye and increases skin elasticity	Anti-wrinkle, anti-puffing and reduces dark circles around eyes
Acetyl tetrapeptide-9	AcTP1	Synthetic	Signal peptide	Increases collagen I synthesis, stimulates lumican synthesis	Anti-aging, anti-wrinkle, firming peptide
Acetyl tetrapeptide-11	AcTP2	Synthetic	Signal peptide	Stimulates keratinocyte cell growth, stimulates synthesis of syndecan-1	Anti-aging, anti-wrinkle, firming peptide

(Continued)

TABLE 14.3 (Continued)

Characteristics of Topical Peptides and Proteins Used as Cosmeceuticals

Peptides and Proteins	Alternate/Generic Names	Source	Peptide Type	Mechanism of Action	Cosmeceutical Uses
Acetyl hexapeptide-3	Argireline® or acetyl hexapeptide-8	Synthetic	Neurotransmitter-inhibitor peptide	Inhibits SNARE complex formation and catecholamine release	Anti-wrinkle especially peri-orbital, skin moisturizer, improves skin's firmness and tone
Acetyl octapeptide-3	SNAP-8 or Acetyl glutamyl heptapeptide-1 or octapeptide	Synthetic	Neurotransmitter-inhibitor peptide	Mimics SNAP-25 N-terminal end, which competes with it	Anti-wrinkle especially peri-orbital, skin moisturizer, improves skin's firmness and tone
AcSDKP	Acetyl-Ser-Asp-Lys-Pro		Signal and inhibitor peptide	Inhibits Smad2 and is antifibrotic Stimulates expression of tight junction proteins Stimulates proliferation of basal epidermal cells, keratinocytes, and fibroblasts Increases fibrillogenesis, GAGs	Increases epidermal thickness Increases collagen III along papillary dermis and collagen IV along basal membrane Modulates hair growth
Pentapeptide-18	Leuphasyl®	Synthetic	Neurotransmitter-inhibitor peptide	Mimics the natural mechanism of enkephalins and inhibits neuronal activity and catecholamine release	Anti-wrinkle (peri-orbital), skin moisturizer, improves skin's firmness and tone
Pentapeptide-3	Vialox®	Synthetic	Neurotransmitter-inhibitor peptide	Competitive antagonist at the acetylcholine receptors	Alternative to Botox®, anti-wrinkle (against expression wrinkles), anti-aging
Pal-KTTKS	Palmitoyl pentapeptide-4 or palmitoyl pentapeptide-3 or palmitoyl oligopeptide or Matrixyl®	Synthetic (pro-collagen I fragment)	Signal peptide	Stimulates collagen I, III, and VI, fibronectin, elastin, and glucosaminoglycan production	Anti-aging, anti-wrinkle
Pal-KT	Palmitoyl lysine-threonine	Synthetic (pro-collagen I fragment)	Signal peptide	Stimulates collagen I, III, IV, fibronectin, elastin, and glucosaminoglycan production	Anti-aging, anti-wrinkle
Palmitoyl VGVAPG	Palmitoyl elastin derived hexapeptide, Pal-Val-Gly-Val-Ala-Pro-Gly	Synthetic (elastin hexapeptide fragment)	Signal peptide	Stimulates angiogenesis, skin fibroblast proliferation, and down-regulates elastin expression. Induces DOPA-positive cell number and enhanced dendrite formation	Anti-aging, skin moisturizing and skin surface smoothing
Tripeptide-10 Citrulline	Decorin-like tetrapeptide (Decorinyl™)	Synthetic	Signal peptide	Regulates collagen fibrillogenesis and influences diameter and placement of collagen fibers	Anti-aging, firming agent

(Continued)

TABLE 14.3 (Continued)

Characteristics of Topical Peptides and Proteins Used as Cosmeceuticals

Peptides and Proteins	Alternate/Generic Names	Source	Peptide Type	Mechanism of Action	Cosmeceutical Uses
Hexapeptide-11	—	Biotechnologic (yeast fermentation)	Signal peptide	Up-regulates key genes responsible for collagen production and important extracellular matrix components	Anti-aging, hair conditioner, hair growth promoter
elaidyl -KFK	Lipospondin or Elaidyl-Lys-Phe-Lys	Synthetic	Signal peptide	Up-regulates collagen and tissue inhibitor of metalloproteinase (TIMP)-1 production and down-regulates MMP-1 in fibroblast cultures	Anti-aging, anti-wrinkle
SECMA 1®	Glu-Asp-Arg-Leu-Lys-Pro	Synthetic (green algae of Ulva)	Signal peptide	Modulates the production of proteoglycans and glycosaminoglycans in human fibroblasts	Anti-aging, anti-wrinkle
Human growth hormone	hGH	Biotechnologic (recombinant)	Signal peptide	Increased IGF-1 production, fibroblast and keratinocyte activity, and sebum production	Anti-aging, anti-wrinkle, after skin resurfacing
Transforming growth factors	TGF- α and TGF- β	Biotechnologic (recombinant)	Signal peptide	Reversibly inhibits keratinocytes and leukocytes growth, promotes keratinocyte migration, chemotactic for macrophages and fibroblasts	Anti-photoaging, anti-wrinkle, post laser uses
Interferon alpha	IFN- α	Biotechnologic (recombinant)	Signal peptide	Increases the concentration of dendritic cells and CD1a and HLA-DR positive cells	Anti-aging, anti-wrinkle
Melatonin	N-acetyl-5-methoxytryptamine OR MSH	Biotechnologic (recombinant)	Anti-oxidant and signal peptide	Reduces the oxidative damage and increases cell viability in fibroblasts	Anti-aging, anti-solar, hair growth promoter
Heat shock protein (70)	HSP70	Biotechnologic (recombinant)	Signal peptide	Protects the cells against apoptosis, aging, and UV damage	Anti-aging, anti-wrinkle
Syn®-Tacks	Palmitoyl dipeptide-5 diaminobutyloyl hydroxythreonine, Palmitoyl dipeptide-6 diaminoxybutyrate	Synthetic	Signal peptide	Stimulates laminin V, collagen type IV, VII and XVII, and integrin	Anti-aging and anti-wrinkle, firming product, sun-care products
Syn®-Ake	Tripeptide-3 or dipeptide diaminobutyroyl benzylamide diacetate	Synthetic	Neurotransmitter-inhibitor peptide	Mimics the effect of <i>waglerin 1</i> , a peptide that is found in the venom of the temple viper, <i>Tropidolaemus wagleri</i> .	Anti-aging, intensive anti-wrinkles

(Continued)

TABLE 14.3 (Continued)

Characteristics of Topical Peptides and Proteins Used as Cosmeceuticals

Peptides and Proteins	Alternate/Generic Names	Source	Peptide Type	Mechanism of Action	Cosmeceutical Uses
Soybean protein/amino acids	Glycine Soja Protein or Preregen®	Natural (soybean seed)	Enzyme inhibitor peptide	Inhibits the formation of proteinases, increases trichoblast and atrichoblast numbers without changing their localization pattern, increases the number and length of the root hairs	Anti-aging, skin moisturizer, used in cleansing detergents, sensitive skin care, anti-solar, regenerating effect. Hair-promoting agent
Keratin proteins/amino acids	Keramino 25®	Natural (human hair and sheep's wool)	Structural peptide	Improves hydration and elasticity of the skin and hair	Skin and hair moisturizer, firming agent, hair shiner
Rice protein/amino acids	Colhibin®	Natural (rice seed)	Enzyme inhibitor peptide	Inhibits MMP activity and induces expression of hyaluronan synthase 2 gene in keratinocytes	Anti-aging, film-former, hair conditioner, skin moisturizer, antisolar
Kinetin	N6-furfuryladenine	Natural (plant-derived growth hormone)	Antioxidant and signal peptide	Delays the onset of aging characteristics in human fibroblasts. Inhibits keratinocyte growth	Anti-wrinkle, anti-aging, anti-solar
Pyratine 6	N6-furfurylamino-tetrahydropyran-2-yladenine	Synthesized from natural plants	Antioxidant and signal peptide	Has anti-ROS and antisenesescence effects on the growth of human skin cells	Anti-wrinkle, anti-aging, anti-solar
Decorinyl™	Tipeptide-10 Citrulline	Synthetic	Signal peptide	Mimics the sequences of decorin that bind to collagen fibrils. Regulates fibrillogenesis and control fibril growth and their uniformity.	Anti-wrinkle, increases skin suppleness and tone
Silk protein	Sericin	Natural (Moddle silk gland of the silkworm <i>Bombyx mori</i>)	Antioxidant, enzyme inhibitor protein, copper chalator protein	Chelates with copper, Inhibits lipid peroxidation and tyrosinase activity and keratinocyte apoptosis	Anti-aging, anti-wrinkle, skin moisturizer
PEP-1-rpS3 fusion protein	—	Biotechnologic (recombinant)	Signal protein	Increases epidermal cells viability and reduces DNA lesions in UV-exposed areas	Anti-aging, anti-wrinkle
Aquaporin	AQP	Natural (extracted from <i>Ajuga turkestanica</i>)	Signal protein	Increases epidermal proliferation and differentiation. Makes stratum corneum thicker	Anti-aging, anti-wrinkle, skin moisturizer

TABLE 14.4

A Summary of Efficacy Data from Controlled Clinical Trials

Peptides	Study ID	Indication of Topical Use	Study Design	Characteristics of Subjects	Treatment Arm(s)	Treatment Protocol	Efficacy
GHK-Cu	145	Skin conditioning (anti-aging)	Non-randomized, active-controlled, clinical trial	Volunteer females	GHK-Cu containing liquid foundation and GHK-Cu containing cream concealer	Formulations were applied for 8 weeks	Sig. improvements in all evaluations of skin condition were found for both products
	146	Anti-aging	Double-blind placebo-controlled clinical trial	71 female volunteers with mild to advanced photodamage	GHK-Cu cream vs. placebo cream	The creams were applied on the faces twice daily for 12 weeks	Sig. improvements for GHK-Cu than placebo for all measurements by week 4
	147	Anti-aging (periorbital)	Double-blind placebo-controlled clinical trial	41 female volunteers with mild to advanced photodamage	GHK-Cu cream vs. vitamin K cream	The creams were applied around the eyes twice daily for 12 weeks	Sig. improvements for GHK-Cu than placebo for all measurements by week 4
	148	Anti-aging	Randomized, double blind, parallel group, placebo-controlled clinical trial	67 female volunteers aged 50–59 with mild to advanced photodamage	GHK-Cu cream vs. placebo cream	Creams were applied on the face twice daily for 12 weeks	GHK-Cu improved skin laxity, clarity, and appearance, reduced fine lines, coarse wrinkles, and mottled hyperpigmentation, and increased skin density and thickness
	148	Anti-aging	Non-randomized untreated-controlled clinical trial	5 female volunteers aged 50–59 with mild to advanced photodamage	GHK-Cu cream vs. no treatment	GHK-Cu cream was applied on the face twice daily for 12 weeks	GHK-Cu strongly stimulated dermal keratinocyte proliferation
	149	Anti-aging	Non-randomized active-controlled parallel-group and within-patient clinical trial	20 healthy volunteers	1- Topical tretinoin 2- Topical vitamin C 3- Topical GHK-cu 4- Topical melatonin	20 subjects received creams to the extensor surface of thighs for 1 month	In terms of increase of pro-collagen synthesis, 4/10, 5/10, 5/10, and 7/10 of patients showed response for tretinoin, vitamin C, melatonin, and GHK-Cu, respectively

(Continued)

TABLE 14.4 (Continued)

A Summary of Efficacy Data from Controlled Clinical Trials

Peptides	Study ID	Indication of Topical Use	Study Design	Characteristics of Subjects	Treatment Arm(s)	Treatment Protocol	Efficacy
Pal-KTTS	150	Anti-aging	Randomized, double-blind, placebo-controlled, within-patient trial	93 Caucasian female volunteers aged 35–55	Pal-KTTS oil-in-water moisturizer vs. placebo oil-in-water moisturizer	Each formulation was applied to the half-face skin twice daily for 12 weeks	Sig. better scores for expert grader assessment and subject self-assessment in age spots
	151	Anti-aging	Randomized double-blind active-vehicle-controlled, within-patient round-robin clinical trial	180 female volunteers aged 35–65	Pal-KTTS facial moisturizer vs. Boswellia Serrata extract vs. moisturizer base (vehicle)	Each formulation was applied to the randomly selected half-face skin twice daily for 8 weeks	Pal-KTTS made sig. reduction in bumpy texture and fine lines/wrinkles compared to other comparators and baseline
Pal-KTTS and Pal-KT	152	Anti-aging	Placebo-controlled clinical trial	17 healthy female volunteers aged 45–55 with loss of elasticity on the forearms	3% cream containing AcTP1 vs. cream containing placebo	The creams were applied twice daily for 112 days	Sig. increase in skin thickness and firmness for active cream. AcTP1 was more effective than placebo too
	153	Anti-aging	Active- and placebo-controlled, clinical trial	60 healthy volunteers	2.5% Syn®-Coll cream vs. 10% palmitoyl pentapeptide-3 cream vs. placebo cream	Creams were applied to facial skin twice daily for 84 days	Syn®-Coll significantly decrease average and maximum relief; when compared to Pal-pentapeptide-3, it showed better sig. results for parameters
Syn®-Coll	154	Anti-aging	Randomized, double-blind, placebo-controlled, parallel-group trial	24 healthy volunteers	1% fibronectin-like peptide cream vs. placebo cream	Creams were applied to lips once and evaluations occurred 1 and 3 h after application	Sig. improvement in hydration, and smoothness in active group were seen

(Continued)

TABLE 14.4 (Continued)

A Summary of Efficacy Data from Controlled Clinical Trials

Peptides	Study ID	Indication of Topical Use	Study Design	Characteristics of Subjects	Treatment Arm(s)	Treatment Protocol	Efficacy
Tripeptide-10	155	Anti-aging	Single-blind, placebo-controlled, parallel-group clinical trial	43 female volunteers aged 40–58	0.01% liposomal tripeptide-10 citrulline cream vs. placebo cream	The creams were applied on the face (temple) daily for 28 days	Tripeptide-10 induced a sig. increase in skin suppleness. No sig. increase in placebo group
Peptamide®6	156	Anti-aging (periorbital)	Placebo-controlled, within-patient clinical trial	25 healthy volunteers	2.80% Peptamide® 6 firming toner vs. control toner	Each cream was applied to half-face (periorbital and cheek) twice daily for 4 weeks	Initial skin elasticity and deformation response were improved at week 4
Kinetin (cytokine)	157	Anti-aging	Randomized, double-blind, active-controlled, within-patient clinical trial	40 female subjects aged 22–57	Kinetin containing lotion vs. retinol containing lotion	Creams were applied to the face twice daily for 12 weeks	Improvement in major parameters with both preparations at week 12
	158	Anti-aging	Randomized, double-blind, placebo-controlled, within-patient clinical trial	52 healthy Taiwanese female and male subjects (age 30–60; 90% female)	Aqueous serum containing kinetin 0.03% plus niacinamide 4% vs. aqueous serum containing only niacinamide 4%	Each cream was applied to one side of the face daily for 12 weeks	Sig. reductions in spot, pore, wrinkle, erythema index, and evenness counts and also sig. increase in corneal hydration status in kinetin group
	159	Anti-aging	Non-randomized, open-label, vehicle-controlled, within-patient study	Three 10-year-old male hairless hybrid dogs	10 µM, 100 µM, 1000 µM, 10000 µM and 2% kinetin solutions	Dorsum of each dog was divided into 10 blocks: 5 of them for different kinetin concentrations and the other 5 as control for 50 days	All concentrations showed sig. improvement in skin color and decrease in the thickness of corneal layers and increase in epidermal thickness

(Continued)

TABLE 14.4 (Continued)

A Summary of Efficacy Data from Controlled Clinical Trials

Peptides	Study ID	Indication of Topical Use	Study Design	Characteristics of Subjects	Treatment Arm(s)	Treatment Protocol	Efficacy
Acetyl tetrapeptide-9 (AcTP1)	152	Anti-aging	Placebo-controlled clinical trial	19 healthy female volunteers aged 60–70 with loss of elasticity on the forearms	3% cream containing AcTP2 vs. cream containing placebo	The creams were applied twice daily for 112 days	Sig. increase in biomechanical parameters of the superficial layers of epidermis was observed for active cream. AcTP2 had 5%–10% better effect than placebo
CRS	160	Anti-aging	Randomized, active-controlled, within-patient, assessor-blind, pilot	12 healthy females with facial wrinkles (42–74 years of age)	CRS cream vs. same cream without TGF- β 1 component (vitamin C base)	Each cream was applied twice daily for 3 months	Sig. improvement in wrinkle scores for CRS and non-sig. for vitamin C
CRS vs. TNS	160	Anti-aging	Randomized, active-controlled, within-patient, assessor-blind, study	20 healthy females with facial wrinkles (29–74 years of age)	CRS cream vs. TNS cream	Each cream was applied twice daily for 3 months	Sig. improvement in wrinkle score for CRS and non-sig. for vitamin C
PSP	161	Anti-aging	Two-center, Randomized, double-blind, placebo-controlled, within-patient trial	20 Caucasian females with demonstrable facial wrinkles (35–65 years of age)	PSP cream vs. placebo cream with same ingredients but no PSP	Each cream was applied to the half-face skin twice daily for 2 months	Roughness parameters were significantly better in PSP group. No difference between two groups
Melatonin	162	Anti-aging, anti-tumor	Randomized double-blind, placebo-controlled, within-patient, clinical trial	20 healthy volunteers aged 22–33	50 μ L Topical melatonin (0.6 mg/cm ²) vs. 50 μ L topical vehicle	Creams were applied on 12 test sites; either 15 minutes before UV irradiation, or 240 minutes after irradiation	Best results for melatonin serum application before irradiation

(Continued)

TABLE 14.4 (Continued)

A Summary of Efficacy Data from Controlled Clinical Trials

Peptides	Study ID	Indication of Topical Use	Study Design	Characteristics of Subjects	Treatment Arm(s)	Treatment Protocol	Efficacy
Keratin peptide	163	Skin moisturizer	Randomized placebo- and untreated – controlled, within-patient, clinical trial	16 healthy female volunteers aged 24–50 with skin types of III to V	3% keratin peptide vs. 3% deionized water in base cream vs. untreated	Each cream was applied to a 9 cm ² area of hand once a day for 12 days	Insignificant difference between topical therapies; although keratin was insignificantly effective for dry. Elasticity results were significantly better for it
	163	Skin moisturizer	Randomized placebo- and untreated – controlled, within-patient, clinical trial	9 healthy female volunteers aged 24–50 with dry skin types of III to V	3% keratin peptide vs. 3% deionized water in base cream vs. untreated	The treated areas were exposed to 2% sodium lauryl sulphate for 2 h to after 12-day daily application of each cream to a randomly assigned 9 cm ² area of hand	There was a significantly smaller decrease in hydration for keratin peptide cream in terms of skin capacitance and TEWL
	164	Skin moisturizer	Randomized active and placebo-controlled within-patient clinical trial	6 healthy Caucasian female volunteers phototype III–IV, aged 24–36	Keratin peptide aqueous solution vs. keratin peptide liposome solution vs. IWL liposomes vs. water vs. 0.9% NaCl solution	Each cream was applied onto marked areas of 9 cm ² once a day for four days	Sig. differences of skin capacitance and elasticity parameters for keratin samples. Combination of keratin peptide with the IWL liposomes showed a sig. beneficial effect
Fibronectin-like peptide	154	Anti-aging	Randomized, double-blind, placebo-controlled, within-patient trial	12 healthy volunteers	1% fibronectin-like peptide cream vs. placebo cream	Each cream was applied to back of hands twice daily for 7 days	Increased smoothness and lightening effects were noticed

(Continued)

TABLE 14.4 (Continued)

A Summary of Efficacy Data from Controlled Clinical Trials

Peptides	Study ID	Indication of Topical Use	Study Design	Characteristics of Subjects	Treatment Arm(s)	Treatment Protocol	Efficacy
Soy protein	165	Anti-aging	Randomized, double-blind, placebo-controlled, within-patient trial	21 healthy females (55 ± 6 years) with skin types of II and III	2% soy extract cream vs. placebo cream	Each cream was applied to volar forearm twice daily for 2 weeks	Papillae index was more increased by soy extract than placebo
	166	Anti-aging	Pseudo-randomized, volunteer-blind, within-patient trial	10 healthy Caucasian females aged between 42 and 67	2% soya biopeptide emulsion vs. placebo emulsion	Control emulsion was applied to left side of the face and soya emulsion to right side twice daily for 4 weeks	Collagen and glycosaminoglycan contents were significantly stimulated by soya extract vs. placebo
Silk Protein	167	Anti-aging and anti-tumor	Randomized active- and vehicle-controlled three-arm clinical trial	30 four-week-old female Hos:HR-1 UVB-exposed hairless mice (three groups of five mice)	Single doses of 5-mg silk protein in 0.2 mL ethanol vs. 5-mg BSA in 0.2 mL ethanol vs. 0.2 mL ethanol	Each treatment group received its solution immediately after single application of 180 mJ/cm ² UVB treatment	Silk protein significantly inhibited UVB-induced elevation and elevated expression of COX-2 protein more than BSA and vehicle
	167	Anti-aging and anti-tumor	Randomized active- and vehicle-controlled three-arm clinical trial	30 four-week-old female Hos:HR-1 UVB-exposed hairless mice (three groups of five mice)	5-mg silk protein in 0.2 mL ethanol vs. 5 mg BSA in 0.2 mL ethanol vs. 0.2 mL ethanol	Each treatment group received its solution immediately after 180 mJ/cm ² of UVB treatment daily for seven days	Silk protein significantly inhibited skin lesion formation and UVB-induced elevation and elevated expression of COX-2 protein more than BSA and vehicle

(Continued)

TABLE 14.4 (Continued)

A Summary of Efficacy Data from Controlled Clinical Trials

Peptides	Study ID	Indication of Topical Use	Study Design	Characteristics of Subjects	Treatment Arm(s)	Treatment Protocol	Efficacy
	168	Skin moisturizer	Untreated-controlled within-patient clinical trial	Six healthy human volunteers of both sexes (three men and three women) aged 22–25	0.2 g Sericin gel vs. no treatment	For hydroxyproline assay, Sericin gel (0.2 g) was applied on the dried skin of the forearm at the test site. For TEWL, the upper portion of forearm was used as the site for application of sericin gel (0.2 g) and lower portion for control	No significant difference in hydroxyproline content, skin impedance and TEWL content were seen; comparing silk peptides and untreated site
	169	Skin moisturizer	Active- and untreated-controlled within-patient clinical trial	Six healthy volunteers	1% silk fibroin vs. 3% silk fibroin vs. 5% silk fibroin vs. 5% silk-pro-100 solutions	1 mL of each solution was applied to inner upper portion of the forearm for 15 minutes and lower portion was left untreated as control (for impedance measurement, only 5% solution were compared)	For TEWL, 5% firoin solution ~ silk-pro-100 > 1% and 3% fibroin solutions. Sig. drop in impedance was observed for both 5% solutions within one hour
Leuphasy1® vs. Argireline®	170	Anti-aging	Active-controlled parallel-group clinical trial	43 healthy female volunteers aged 39–64	Cream containing 5% Leuphasy1® solution (0.05%) vs. cream containing 5% Argireline® solution (0.05%) vs. combination	Each cream was applied twice daily around the eyes of 14 volunteers for 28 days	Mean wrinkle reduction were 11.64% vs. 16.26% vs. 24.62% for Leuphasy1®, Argireline® and combination, respectively

(Continued)

TABLE 14.4 (Continued)

A Summary of Efficacy Data from Controlled Clinical Trials

Peptides	Study ID	Indication of Topical Use	Study Design	Characteristics of Subjects	Treatment Arm(s)	Treatment Protocol	Efficacy
lipopentapeptide	171	Anti-aging	Randomized active-controlled	Nine healthy photoaged volunteers (2 men, 7 women; aged 42–79)	6% vs. 2% total active complex cream (lipopentapeptide, white lupin peptide, antioxidants); untreated sites have given Retin-A	Substances were patch tested separately to the extensor aspect of forearm on days 1, 4, and 8. Patch tests were removed on day 12	6% formula significantly increased fibrillin-1 and procollagen I deposition. Retin-A and 6% complex was the best triggers for fibrillin-1 and procollagen I deposition, respectively
Acetyl hexapeptide-3 (Argireline)	172	Anti-aging	Vehicle-controlled, open-label, trial	10 healthy women volunteers	O/W emulsion containing 10% Argireline® solution	Solution was applied twice daily around the eyes during 30 days	Sig. more reduction in the depth of wrinkles for Argireline group
Elaidyl-KFK	173	Skin repair	<i>Ex vivo</i> study	Skin tissue section	Elaidyl-KFK solution	Different solutions were applied on skin tissue section	The inhibition of MMP-2 and MMP-9-mediated degradation of collagen fibers and elastin fibers, respectively, by elaidyl-KFK could be demonstrated
Acetyl octapeptide-3 (SNAP-8)	174	Anti-aging	Placebo-controlled clinical trial	45 healthy volunteers	4% SYN®-Ake vs. 10% acetyl hexapeptide-3 (Argireline®) vs. placebo	Each cream was applied to the skin of forehead twice daily for 28 days	Before-after measurements were sig. for Syn®-Ake only

PEP-1-rpS3 protect against apoptosis and UV assault to the skin respectively. Lastly, keratin, derived from human hair or sheep's wool, improves the hydration and elasticity of the skin. Signal proteins have various protective effects on skin in addition to improving collagen synthesis and granulation tissue formation.

Two other types of topical peptides include enzyme inhibitors and neurotransmitter inhibitors. In contrast to signal peptides, enzyme inhibitor peptides act upon enzymes directly and indirectly to promote cellular anti-aging effects in the dermis related to fibrillogenesis and deposition. Soybean oil and rice protein inhibit proteinases and MMP cleavage activity respectively. Acetyl tetrapeptide-5 inhibits collagen glycation and reduces edema by inhibiting angiotensin converting enzyme, while silk protein has antioxidant properties associated with copper. Neurotransmitter peptides proteolyze acetylcholine-releasing proteins at the neuromuscular junction, such as SNAP-25, syntaxin-1, and synaptobrevin. Peptides which affect the biological function of acetylcholine include acetyl hexapeptide-3, Argireline, Pentapeptide-18, Pentapeptide-3, acetyl octapeptide-3, and tripeptide-3.

While the four functional categories of topical peptides relay common themes of the drugs' cellular anti-aging effects such as collagen formation, other possible roles for topical proteins are currently being investigated. For example, lipid deposition in the epidermis is known to decrease in aged skin.² A recent study found that treatment with peptides of a potato hydrolysate stimulates keratinocytes to produce more cholesterol, alpha-hydroxy fatty acids, and ceramides at the skin's surface. This effect was more pronounced in the keratinocytes of aged persons than those of younger donors. Activation of peroxisome proliferation-activated receptors (PPARs) is believed to be the signal process that stimulates lipid biosynthesis. Although the specific proteins responsible for this effect are still unknown, this opens an exciting new area of anti-aging topical protein and peptide development.³⁰

Topical Signal Oligopeptides

GHK-Cu, GHK-Mn, Pal-GHK, Biopeptide-CL

GHK-Cu, or copper tripeptide complex, is a carrier signal peptide discovered in the 1970s for its role in copper transport and hepatocyte survival.³¹ Since then, it has been noted as a growth factor for various differentiated cells, a chemotactic agent for macrophages, and a stimulator of nervous tissue regeneration and skin remodeling.³²⁻³⁴ GHK-Cu and related oligopeptides, GHK-Mn (manganese tripeptide complex), and Pal-GHK (biopeptide-CL), are less irritating to skin than retinol and tretinoin, making GHK derivatives a desirable option for reducing fine wrinkles in skin.³⁵

In anti-aging treatment, GHK-Cu's role is to stimulate synthesis of EMPs by selectively increasing the expression of metalloproteinase-2 (MMP-2).³⁶ Also called gelatinase A, this enzyme plays a role in angiogenesis and the breakdown of extra-large collagen IV aggregates in scars, while promoting collagen I formation. MMP-2 also fosters an anti-inflammatory milieu and is known to regulate collagen synthesis in tissue remodeling and embryonic development.³⁷ As a modulator of MMP-2, GHK-Cu has been termed a matrixin that affects glycosaminoglycan (GAG) synthesis. Treatment with GHK-Cu on rat wounds resulted in increased decorin deposition at the wound site.³⁸ Since decorin is a GAG involved with collagen fibril organization, this study shows how GHK-Cu stimulation of collagen formation can benefit aging skin.³⁹ GHK-Cu also increases fibroblast proliferation and angiogenesis.⁴⁰ The upregulation of vascular endothelial growth factor and fibroblastic growth factor in skin treated with GHK-Cu has been observed.⁴¹ In a recent study, GHK-Cu also decreased secretion of the proinflammatory cytokine interleukin-6 (IL-6) from dermal fibroblasts *in vitro*.⁴² It has been proposed as a topical anti-inflammatory therapy alternative to corticosteroids, GHK-Cu.⁴³ One study on dorsally irradiated Sprague Dawley rats which were subsequently treated with GHK-Cu at the wound site found no differences in angiogenesis and blood flow to the wound site compared to control groups.⁴⁴ Despite some mixed results on the vascular effects of GHK-Cu, GHK-Cu's anti-aging and wound healing abilities have been well established molecularly, especially as a modulator in the formation of collagen I and other EMPs including GAGs, PGs, and elastin.

GHK-Cu skin permeability has been investigated extensively. One study used an SC lipophilic model membrane on a Flynn diffusion cell to show that the Kp of GHK-Cu at physiological pH is 3.34×10^{-6} , higher than it is in an acidic pH: 0.63×10^{-6} , and much higher than Cu(2+) alone: 0.27×10^{-6} .⁴⁵ The

lipophilic layer on this membrane was composed mainly of cerasomes, found naturally in the SC. Using mass spectroscopy, this study also concluded that the GHK-Cu degradation mechanism lies in the histidine-lysine peptide bond.⁴⁵ A later study by the same investigators used a Franz diffusion cell liposomal membrane to show that GHK-Cu permeability is 1.35×10^{-9} , similar to that of GHK alone at 1.36×10^{-9} .⁴⁶ The Franz model utilizes liquid crystalline systems to imitate the intercellular lipids of the SC. The main difference between the two studies is that the Flynn model investigated GHK-Cu permeation through an aqueous solution, while the Franz model elucidated the copper peptide complex's permeation ability through an emulsion. This is important since most cosmeceuticals are provided in emulsion form.

Originally, it was believed that GHK was only a carrier peptide for copper, since it significantly improves copper's penetrative ability through skin. Copper is well known for its role in enzymatic reactions involved with skin repair and collagen production. For example, GHK transdermal delivery of copper can contribute to the copper-dependent enzyme lysyl oxidase, which mediates crosslinking of tropoelastin in the ECM.¹⁷ However, a recent study indicated that Cu-free GHK also had a beneficial effect. Cu-free GHK promoted the stem-ness and proliferative ability of basal epithelial cells, and increased the expression of integrin by keratinocytes.⁴⁷ Another study reported that while copper and manganese ions increase the activity of antioxidant enzymes, GHK itself is responsible for increased fibroblast proliferation.³⁵ Therefore, GHK-Cu and GHK-Mn are termed as both signal and carrier peptides. Furthermore, GHK may be covalently bonded to palmitoyl derivatives to increase their transdermal delivery potential without compromising beneficial anti-aging effects to the skin. Pal-GHK, or Biopeptide CL, is GHK conjugated to palmitic acid. Recently, a mass spectroscopy based assay was developed to detect the presence of pamitoylated oligopeptides in anti-wrinkle creams.⁴⁸

Efficacy data displays GHK-Cu's significant anti-aging effects when used topically. In one nonrandomized control trial, ten volunteers applied topical GHK-Cu and vitamin C on each of their inner thighs. Ten other volunteers applied tretinoin and melatonin. Topical GHK-Cu increased procollagen synthesis in seven of ten volunteers, compared to increased procollagen in four of ten volunteers treated with tretinoin, and five of ten volunteers treated with vitamin C or melatonin. Due to the study design, however, vitamin C and tretinoin were not compared to GHK-Cu on the same subjects.⁴⁹ A controlled *ex vivo* study showed that biotinyl-GHK simulated keratinocyte migration and the remodeling and formation of collagen and laminin.⁵⁰ Additionally, two GHK-Cu containing cosmetics, a foundation and a concealer, were evaluated over an eight-week period to facial skin. Both cosmetics showed significant improvements in the skin's viscoelasticity, with visual changes in appearance in as early as two weeks.⁵¹ A 12-week placebo-controlled GHK-Cu study on 71 women with mild photodamage showed structural changes to facial skin in as soon as one week, with increased skin laxity and clarity. At week 4, there was a significant improvement of wrinkles over placebo. Ultrasound showed an increase in facial skin density and thickness as well. No irritation or adverse consequences were reported.⁵² A randomized double-blinded placebo-controlled study with 67 volunteers also showed the anti-aging effects of GHK-Cu on facial skin, reducing hyperpigmentation in addition to coarse and fine wrinkles. Dermal keratinocyte proliferation was also induced for all five participants who applied the copper peptide cream to their forearms.⁵³ GHK-Cu's efficacy on periorbital skin has also been investigated in a study including 41 females with photodamage. Compared to vitamin K cream, cream with GHK-Cu significantly improved fine lines, wrinkles, skin thickness, density, viscoelasticity, and the overall appearance of the eyelids.⁵⁴

Properties of GHK-Mn have also been investigated. Like copper, a manganese complex can be used by superoxide dismutase to prevent oxidative damage to the body.⁵⁵ This is one of the mechanisms by which manganese oligopeptides can prevent UV induced photoaging of skin through the creation of ROS, in addition to stimulating fibroblast growth and EMP production to diminish sallowness and improving skin texture.⁵⁶

Pal-KTTKS, SAP, and Pal-KT

KTTKS is a peptide fragment of the carboxy terminal of the propeptide for type I collagen, residues 212–216. Discovered in 1993, KTTKS was regarded as the minimum sequence necessary to stimulate the production of collagens I and III as well as fibronectin and elastin by various mesenchymal cells. The K_p of KTTKS is low, approximately 3.16×10^{-9} . Due to a molecular weight of over 500 and its hydrophilic

nature, it is difficult for KTTKS to reach the skin's dermis. Therefore, like GHK, KTTKS may be linked to a palmitoyl fatty acid derivative to enhance its permeation capacity. Pal-KTTKS is commercially known as Matrixyl, and it is 17 times more permeable than KTTKS alone.⁵⁷

The ability of KTTKS to modulate ECM matrix production is not cell-specific. Through auto-regulatory feedback, KTTKS can stimulate extracellular matrix synthesis 80% as well as the procollagen peptide in fibroblasts in a dose and time dependent manner.^{58,59} One study proposed that this process occurs post-transcriptionally, affecting the biosynthetic pathway of collagen synthesis rather than its export or degradation pathways.⁶⁰ It has also been shown that KTTKS increases procollagen mRNA in the cell through acting on TGF β .⁶¹ In aging skin, extracellular lipid layers forming the SC barrier thin progressively. One study showed that a mixture of Pal-KTTKS and olive oil applied to human skin cells for 6 hours upregulated the expression of genes involved in cholesterol biosynthesis, improving SC barrier function.⁶² Genes associated with wound healing are upregulated in cells treated with Pal-KTTKS, including lysyl oxidase, which aids in crosslinking elastin filaments to help retain the skin's elasticity.⁵⁰ A shortened version of Pal-KTTKS, Pal-KT, has also shown efficacy in helping smooth wrinkles and repair the skin SC.⁶³

The activity of Pal-KTTKS fragments in the cell has recently been uncovered. A recent study showed that Pal-KTTKS forms tape-like structures in human dermal fibroblasts, and can aggregate together to form fibrillar structures, with the lipophilic portion forming an internal bilayer. This suggests that the bioactivity of topical Pal-KTTKS is induced through self-assembly, and the palmitoyl addition to the KTTKS not only assists in skin penetration, but also helps organize the peptide fragments inside fibroblasts. The Sirius red assay is also used in this study to show increased fibroblast collagen production in dermal fibroblasts treated with Pal-KTTKS.⁶⁴ One recent study also showed that Pal-KTTKS-induced procollagen synthesis is linked to the cell's bioenergy cofactor levels, including the ratio of NAD⁺ to NADH. By using dill extract in addition to a three-way complex consisting of niacinamide, Pal-KTTKS, and olivem, potentiates the ability of dermal fibroblasts to produce procollagen and elastin fibers.⁶⁵

Efficacy data on Pal-KTTKS is extensive. Summarized in [Table 14.3](#), Pal-KTTKS has been shown in numerous randomized control studies to improve fine lines and wrinkles, the appearance of pores on cheeks, bumpy texture, and age spots. However, one evidence-based study of topical skin rejuvenation comparing Pal-KTTKS to tretinoin, niacinamide, lipoic acid, phytoestrogens, ectoin, kinetin, and green tea extracts found that Pal-KTTKS resulted in epidermal thickening and reduction of fine lines and wrinkles better than only the ectoin, kinetin, and green tea extracts.⁶⁶

Ascorbic acid, or vitamin C, may also be covalently bonded to the short peptide KTTKS. Named the stable ascorbyl pentapeptide (SAP), this conjugate resists degradation at the skin's surface, does not cause cytotoxicity, and has been shown to superiorly promote collagen biosynthesis in comparison to KTTKS or L-ascorbic acid alone. This compound inhibits tyrosinase activity and melanogenesis, showing its potential for use as an anti-aging cosmeceutical.⁶⁷ This peptide has not yet been used in human trials.

Syn-Coll and Biopeptide-EL

Syn-Coll, or palmitoyl tripeptide-3/5 (Palmitoyl-lysyl-valyl-lysine bistrifluoroacetate salt), is a synthetic signal oligopeptide that has been shown to promote collagen formation in both *in vitro* and *in vivo* studies through the growth factor TGF β . The mechanism of this peptide is similar to thrombospondin I (TSPI) activity. TSPI is expressed in dermal cells, especially during wound healing. This protein binds to latent TGF β and induces conformational change, increasing the production of collagen as a downstream effect.⁶⁸ One study showed that treatment of TSPI null mouse wounds with the peptide KRFK was able to rescue the TSPI-dependent activation of TGF β in dermal cells.⁶⁹ Syn-Coll is a derivative of this sequence that has been coupled to a fatty acid moiety for increased permeation. In dermal fibroblast cells, the pharmacologic effects of a related peptide, KFK, is to increase collagen synthesis and down-regulate MMP-1 expression through TGF β .⁶⁸ A controlled trial on 60 volunteers showed that Syn-Coll reduced skin roughness better than both placebo and Pal-KTTKS creams, when applied twice daily for 84 days.⁷⁰

Biopeptide-EL is a palmitoyl oligopeptide comprised of Pal-VGVVAPG. The peptide acts on the growth factor TGF β to stimulate fibrillogenesis. A cream marketed by Sederma also contains inactive

ingredients glyceryl polymethacrylate and PEG-8 in addition to the oligopeptide as viscosity and texturing agents.

Tripeptide-10 Citrulline

Decorin is a leucine-rich proteoglycan commonly found amongst ECPs. Its role is to stabilize the organization of collagen fibrils into longer, thicker cables, helping support the extracellular scaffold of the epidermis. A horseshoe-shaped molecule, decorin binds two triple helix collagen fibrils and orients them in a staggered manner to add to the growing collagen fiber and maintain tissue shape. Tripeptide-10 Citrulline, or Decorinyl, is a tetrapeptide engineered in 2008 from decorin, whose peptide chain follows the +, −, 0, + charge pattern shown to be necessary for the binding of decorin to collagen. Not only does Tripeptide-10 Citrulline help regulate fibrillogenesis, it also regulates collagen fiber dimensions and uniformity, making this oligopeptide a good candidate for maintaining elasticity of skin and reducing wrinkles. A single-blinded parallel group controlled trial compared cream containing Tripeptide-10 Citrulline to placebo. After 28 days, results showed an increase of skin suppleness by 54%, an effect seen in 95% of volunteers.³

Palmitoyl VGVAPG

Gly-Val-Ala-Pro-Gly (VGVAPG) is a peptide fragment of tropoelastin, containing a binding site to dermal fibroblasts. VGVAPG has been shown to stimulate the growth of dermal fibroblasts by stimulating a G protein coupled receptor on their cell surface. Unlike other signal peptides, VGVAPG has not been shown to directly affect fibrillogenesis and collagen formation. Instead, it downregulates elastin expression and plays an important regulatory role in ECM formation. VGVAPG has also been shown to affect angiogenesis. VGVAPG increases the skin's circulation and maintains its elasticity and structure to promote younger looking skin.¹⁷

Hexapeptide-11 and Hexapeptide-14

Pentamide-6, or Hexapeptide-11, was originally isolated from *Saccharomyces* yeast fermentation. Pentamide-6 directly affects dermal cell senescence by downregulating key genes involved in apoptosis. The cellular proteins ataxia telangiectasia mutated (ATM) and p53 have been shown to be hyperactive in degenerative aging pathologies, leading to cellular senescence. Senescent cells in skin can cause dermal thinning, loss of subcutaneous fat, decreased hair growth, and slower wound healing.⁷¹ Pentamide-6 is a hexapeptide with the structure Phe-Val-Ala-Pro-Phe-Pro (FVAPFP). This oligopeptide helps promote younger looking skin by reversibly downregulating ATMP and p53 at peptide concentrations of 0.1%–1.0%. By targeting the cellular aging process, FVAPFP has been shown to modulate senescence in both intrinsically and extrinsically aged fibroblasts, as well as extrinsically aged dermal papillae cells *in vitro*.⁷² This signal oligopeptide has been shown to increase fibrillogenesis through growth factors, and ECPs increase transmembrane and cell shock proteins, and promote hair growth. A clinical trial conducted on 25 subjects showed its ability to increase skin elasticity and reduce deformity in facial skin.⁷³

Hexapeptide-14 is another oligopeptide that increases fibrillogenesis. Its mechanism is to block MMP-9 collagenase activity. An *in vitro* study on the release of digested gelatin showed that the combination of palmitoyl-hexapeptide-14 and golgi extract significantly inhibits MMP-9 function. A 12-week human panel test with 29 volunteers showed that the ability of Palmitoyl hexapeptide-14 to reduce fine lines and wrinkles is comparable to tretinoin, and does not cause irritation.⁷⁴

Palmitoyl Tetrapeptide-7

Palmitoyl tetrapeptide-7 is derived from dehydroepiandrosterone, a steroid normally synthesized and released from the adrenal gland. DHEA has been shown to reduce inflammation, support wound healing, and slow down the skin aging process. The ability of palmitoyl tetrapeptide-7 downregulates IL-6 and

other proinflammatory cytokines has been shown to be comparable to anti-inflammatory properties of DHEA *in vitro* in both resting cells and cells stressed with inflammation. Rigin, a cream containing Palmitoyl tetrapeptide-7, has been shown to improve skin elasticity and texture.⁷⁵

Signal Acetyl Tetrapeptides

AcSDKP is an oligopeptide composed of acetyl-Ser-Asp-Lys-Pro. Found at low concentrations endogenously, AcSDKP is produced from thymosin and inhibits the phosphorylation of Smad2, therefore downsizing the expression of genes regulated by TGF β . This mechanism mediates an antifibrotic effect and a reduction in edema. AcSDKP is catabolized almost exclusively by angiotensin converting enzyme I (ACEI), although ACEI-resistant analogs have been created.⁷⁶ AcSDKP has been recognized as a potent inducer of angiogenesis and an anti-inflammatory agent, also contributing to its anti-fibrotic effects. Its cutaneous anti-aging effects have also been investigated.⁷⁷ AcSDKP at a concentration of 10^{-7} – 10^{-11} stimulates the expression of proteins that strengthen tight junctions, including claudin-1, occluding, and ZO-1. In an *ex vivo* study, topical AcSDKP accelerated skin healing after UV irradiation. AcSDKP also stimulates the proliferation of keratinocytes, fibroblasts, and epidermal basal layer cells. Topical application of 10^{-5} M AcSDKP also inhibits aging of human skin explants by significantly increasing epidermal thickness after only six days, increases collagen III along the papillary dermis and collagen IV along the basal membrane, with a concomitant increase in GAGs, especially HA. This peptide also modulates the growth of human hair in an *ex vivo* study. Treatment of normal human dermal fibroblast cells with AcSDKP showed increased collagen I synthesis and SIRT1, improving skin structure and increasing cell longevity.⁷⁸ In one study, topically administered AcSDKP on an *ex vivo* skin-explant model significantly increases epidermis thickness after only six days of treatment with 10^{-8} M AcSKDP. In addition to upregulating the expression of collagen and fibronectin along the dermo-epithelial junction, AcSKDP also increases GAG deposited in the ECM, especially hyaluronic acid. Lastly, AcSDKP encourages dermal fibroblasts and keratinocytes to proliferate and modulates hair growth.⁷⁹

Two other signal acetyl tetrapeptides include acetyl tetrapeptide 9 and 11 (AcTP1 and AcTP2). Proteoglycans lumican and syndecan-1 play a role in collagen fibril stabilization during fibrillogenesis. Lumican is located in the dermis while syndecan-1 is in the basal membrane of the epidermis. AcTP1 and AcTP2 stimulate lumican and syndecan-1 synthesis, respectively.⁸⁰ Clinical trials showed that treatment with AcTP1 and 2 resulted in thicker and firmer skin, and both peptides were 5%–10% more effective than placebo.⁷³

Kinetin and Pyrantine-6

Kinetin, 6-furfurylaminopurine, was the first isolated cytokinin growth factor. Kinetin has inherent antioxidant properties and is known to delay senescence in plant cells. In 1994, it was shown to also delay aging in human dermal fibroblasts, without harmful effects such as increased cell proliferation or transformation leading to carcinogenesis. Compared to cells treated with kinetin, which retained normal morphology, control cells had highly polymerized actin filaments and disorganized microtubules, and a decrease in protein synthesis by a factor of three. Different mechanisms have been proposed, including stimulation of protein elongation factors, interaction with ribosomal proteins, and other signal transduction pathways promoting protein synthesis.⁸¹ It has also been shown to induce differentiation of keratinocytes undergoing aging, especially in the presence of calcium.⁸² Moreover, kinetin acts indirectly as an antioxidant and increases superoxide dismutase activity. In hairless dogs, it has been shown to decrease the density of melanin granules throughout all of the epidermal layers.⁸³ Kinetin's anti-aging effects on skin were compared to those of retinol in a randomized double blinded 12-week trial. Both compounds showed significant improvement in aging characteristics of skin.⁷³ In another study, 18 volunteers with mild to moderately photodamaged skin used a moisturizing cream containing 0.1% kinetin combined with sunscreen application. Subjects had high tolerability for the kinetin cream and improved the appearance of photodamaged skin.⁸⁴ Asian women who applied topical kinetin and niacinamide compared to only niacinamide showed that kinetin helped reduce age spots, pore size, wrinkles, and evenness.⁸⁵ Other clinical trials have shown that kinetin increases elasticity of the skin but does not

significantly support the skin's ability to retain water.⁷³ Recently, a skin cream containing N-acetylfarnesyl-cysteine was found superior to kinetin in its anti-inflammatory and anti-oxidant properties.⁸⁶ An evidence-based study on topical skin rejuvenation found that kinetin is not as effective on wrinkles and epidermal thickening as Pal-KTTKS, niacinamide, or tretinoin.⁶⁶

Pyratine-6 is a molecule with a structure similar to kinetin. Like kinetin, it has the ability to slow down senescence onset in human skin cells, and to neutralize reactive oxygen species that can lead to skin aging. A single-arm longitudinal study on 40 women with photodamaged facial skin who applied pyratine-6 to their faces showed significant improvement in skin moisture and roughness in two weeks. At four weeks, there was also significant improvement in mottled hyperpigmentation, facial erythema, and wrinkles.⁸⁷ Pyratine-6 has also trialed as a topical treatment of mild to moderate rosacea.⁸⁸

Melatonin

Melatonin is a lipophilic peptide hormone normally secreted by the pineal gland that plays a role in hair growth, immunoregulation, and aging, among other functions. Melanin is also synthesized and metabolized in various human skin cells, which commonly express melatonin receptor 1. As a free radical scavenger of H₂O₂, OH, and superoxide, melatonin improves the survival of fibroblasts irradiated by UVB and ionizing light. Melatonin also upregulates the expression of the Nrf2 transcription factor in UV-irradiated human keratinocytes, which stimulates production of antioxidant enzymes such as superoxide dismutase.⁸⁹

There has been tremendous recent research on the biology of melatonin in human skin cells. Metabolites of melatonin in human skin cells including fibroblasts, keratinocytes, and melanocytes results in regulating the proliferation of keratinocytes *in vitro*. Keratin-14 is a marker of undifferentiated keratinocytes while keratin-10 localizes keratinocytes differentiating into the stratum spinosum and granulosum. By increasing the expression of keratin-10 and keratin-14 in the epidermis, melatonin plays a role in constructing and strengthening the epidermal barrier.⁹⁰ In addition, melatonin prevents UV related apoptosis in keratinocytes. Upregulation of heat shock protein 70 (HSP70) is a marker for keratinocyte exposure to UV radiation. Melatonin prevents an increase in HSP70 expression as a result of UV light exposure.⁹¹ Melatonin has also been shown to attenuate UVA-induced cell changes in dermal fibroblasts *in vitro*. Melatonin prevented the UVA related change in ECP production and induction of heme oxygenase.⁹² Importantly, melatonin downregulates collagenases such as MMP-1, MMP-3, and MMP-10.

One clinical trial included 20 patients who were treated with 0.5% topical melatonin at different times before or after UV exposure. In this study, melatonin only suppressed skin erythema if it was applied before UV exposure.⁹³ In other studies, melatonin has been shown to suppress skin erythema after UV light exposure.⁹⁴ Compared to vitamin C and trolox, melanin is a more powerful antioxidant.⁷³

It has been shown that exogenous melatonin is more beneficial if applied topically rather than taken orally due to the first-pass effect of the liver. Due to its lipophilic structure, melatonin can gather in a depot on the stratum corneum.⁹³ The effect of melatonin-loaded emulsions on skin was recently investigated *in vivo*. A Franz diffusion model showed that the emulsions could have a K_p as high as 1.13×10^{-3} cm/hr. Two-step release patterns of the drug were observed, where 80% of the melatonin was released in the first two hours, followed by a slower phase of release. Retention of melatonin in the skin after 12 months was also demonstrated. The emulsion's antioxidant activity remained after a storage period of 12 months. This cosmeceutical's photoprotective effect was also demonstrated *in vivo*. Compared to control, the melatonin emulsions prevented structural abnormalities in the epidermis and lowered the rate of trans-epidermal water loss. Moreover, all emulsions tested are not irritating to skin.⁹⁵

Interferon- α

IFN α is a protein produced by many different cell types in response to immunological stressors in their microenvironment, including Langerhans cells and dermal dendritic cells (DCs).⁹⁶ The ability of Langerhans cells to stimulate T cells confers an immunological advantage that becomes compromised as skin ages, both intrinsically and due to photodamage, resulting in a gradual loss of Langerhans cell density. Dendritic cells are also diminished in intrinsically aged or UV irradiated skin. Due to this, UV

radiation is a powerful source of immunosuppression.⁹⁷ However, IFN α can be used to improve immune surveillance in aged skin by increasing the concentration of dendritic cells, Langerhans cells, and other antigen-presenting HLA-DR+ cells. In one clinical study, application of an IFN α cream before UV irradiation stimulated the proliferation of these cells, consequently improving immune surveillance in aged skin.⁹⁸

Growth Factors

Growth factors stimulate keratinocytes to differentiate, proliferate, and migrate to different layers of the skin. Epidermal, fibroblast, and hepatocyte growth factor (HGF) families as well as insulin-like growth factor enhance keratinocyte growth. In turn, keratinocytes secrete many factors, such as granulocyte-macrophage colony stimulating growth factor (G-CSF), platelet derived growth factor (PDGF), VEGF, and pro-inflammatory interleukins, including IL-6 and IL-8 to modulate cell migration to skin and regulate their microenvironment. TGF α , which stimulates fibrillogenesis in fibroblasts, is part of the epidermal growth factor family and is also secreted by keratinocytes. TGF β suppresses keratinocyte growth, but like TGF α it is a powerful inducer of migration in these cells.⁹⁹ Bone morphogenic protein also induces keratinocyte proliferation and migration in human skin.¹⁰⁰ A recent study showed how topical basic fibroblast growth factor (bFGF) promotes skin barrier recovery in mice, resulting in less transepithelial water loss and keratinocyte proliferation. Its effects are amplified during the absence of other growth factors that downregulate FGF receptors, such as EGF.¹⁰¹ Moreover, topical recombinant human EGF accelerated wound healing and skin collagen deposition in rats.¹⁰²

Growth factors also directly affect enzymes that synthesize GAGs such as hyaluronan. EGF upregulates and TGF β downregulates hyaluronan synthases 2 and 3 in keratinocytes. These characteristics of EGF and TGF β have been linked to the ability of EGF to promote keratinocyte proliferation, versus the anti-proliferative but pro-differentiation effects of TGF β on keratinocytes.¹⁰³

Several combinations of these cytokines, chemokines, and growth factors have been used as topical anti-aging agents. Cell rejuvenation serum (CRS) contains TGF β encapsulated by liposomes, ascorbic acid, and *Cimicifuga racemosa* extract in a silicone base. Another cream, called TNS, contains VEGF, PDGF, G-CSF, HGF, IL-6, and IL-8 in addition to TGF β . In one study, the specific contributions of TGF β were analyzed by comparing CRS to CRS cream without any growth factors. Patients treated with CRS containing TGF β had significant improvements in wrinkles, nearly 15% more compared to cream without it. TNS and CRS comparison in a clinical trial revealed that both creams produced comparable and significant improvement in wrinkles. TNS by itself was found to provide maximal benefits in the periorbital area and result in epidermal thickening. PSP is a different cream containing processed skin proteins, proprietary growth factor, and cytokines extracted from cultured first trimester fetal human dermal fibroblasts. Anti-aging effects of PSP cream showed dramatic anti-aging improvements in the periorbital and chin wrinkles in one trial. Another trial showed reduced dark circles, firmness, and improved texture in addition to decreased periorbital wrinkles as a result of the PSP cream, but not significantly.⁷³

Heat Shock Proteins (HSPs)

As a result of oxidative modification of intracellular proteins by ROS, accumulation of AGEs induces apoptosis. In human dermal fibroblasts, endothelial cells, and keratinocytes, exposure to UV and subsequent ROS production, intracellular proteins are modified by oxidation, leading to senescence.¹⁰⁴ Moreover, AGEs have also been shown to accumulate in the ECM, through the modification of collagen and elastin, and interact with receptors on dermal fibroblasts. This process hastens skin aging. In human foreskin fibroblasts, it was shown that fibroblast receptors for AGEs were upregulated in the presence of ligands and due to UV exposure. Downstream signaling of these receptors resulted in the production of proteases that destroy the skin's basement membrane.¹⁰⁵

HSPs have been shown to have a protective effect on skin cells during this process. Bacterial HSP60 protected keratinocytes from UV-mediated apoptosis through a mitogen-activated protein kinase signal transduction process.¹⁰⁶ Bacterial HSP60 also increases epithelial cell migration.¹⁰⁷ Other HSPs, including HSP70 and HSP90, are involved in protein folding and maintenance of inactive extracellular receptors, respectively. HSP47 is involved with collagen formation, and HSP27 is linked to the structural

integrity of actin binding proteins. HSP72, the most abundant HSP in skin cells, has been shown to refold damaged proteins and interfere with cell apoptotic pathways.¹⁰⁸ One study showed that pretreatment of aged skin cells with a natural nontoxic extracellular inducer of HSP72 results in protection from UV and inflammatory cell stress via HSP72, and generates a response comparable to young skin cells.¹⁰⁹ In one clinical study, HSP70 production in skin was induced through topical Artemis extract. The extract was applied to half of the subjects before UV exposure, and resulted in significantly higher HSP70 expression in aged cells.¹¹⁰

PEP-rpS3

As one of the components of the 40S small unit of eukaryotic ribosomes, rpS3 has endonuclease activity involved with the repair of UV-damaged DNA. PEP-1 is a carrier protein designed from a small region of protein domains called protein transduction domains. Upon topical application, these domains allow the delivery of conjugated exogenous drugs into skin cells.

One study showed that PEP-rpS3 may be directly transduced into epidermal and dermal skin cells through topical application. The study also showed that PEP-rpS3 efficiently protects against UV-mediated cell death by significantly reducing the amount of DNA fragmentation in the cell, showing that this protein induces DNA damage repair in the cell. This protection was shown to be time and dose-dependent.¹¹¹

In another study, PEP-rpS3 significantly reduces inflammation in cells as well. Topical application of PEP-rpS3 resulted in decreased expression of cyclooxygenase-2 (COX2) and pro-inflammatory cytokines, as well as reducing the activation of pro-inflammatory nuclear factor—kappa B. This shows that PEP-rpS3 can be used as a therapeutic agent to reduce skin inflammation in addition to protecting against UV-mediated damage.¹¹²

Keratin

Keratins are epithelial-specific intermediate filaments and play an important cytostructural role in cells, in addition to cell functions such as motility, proliferation, and apoptosis. They also have a protective role for epithelial cells, helping cells contend with environmental stressors such as mechanical insults. There are over 50 different types of keratin proteins, highly conserved across mammals.¹¹³ Disorders in keratin production often result in hyperkeratosis, or thickening of SC due to trauma. Topical keratins have been shown to reduce the degree of keratodermas. Keratin can be extracted from human hair or sheep's wool, and is commonly used in skin moisturizers and topical hair strengthening agents.

Many studies have been conducted to show the beneficial effects of keratin on skin renewal. Wool-derived keratin has recently been shown to stimulate keratinocyte migration as well as types IV and VII collagen expression in fibroblasts. This shows that treatment with keratin results in rejuvenation of the epithelium as well as strengthening of the epithelial basement membrane.¹¹⁴ A new keratin-based hydrogel was used on a patient with epidermolysis bullosa, and resulted in improved robustness of skin and healing.¹¹⁵ A randomized trial comparing 3% keratin to control showed that keratin is effective on disturbed skin.¹¹⁶ Another study showed that topical keratin treatment leads to higher skin elasticity and capacitance. Keratins conjugated to liposomes made of internal wood lipids are more effective than topical aqueous solutions.¹¹⁷

Studies have also been conducted on the topical application of synthetic fibronectin-like peptides. These, like keratin, smoothed the skin surface and also reduced hyperpigmentation of the skin.¹¹⁸

Topical Enzyme Inhibitor Peptides

Soybean Protein

Extract from soybeans, containing isoflavones, possess strong anti-inflammatory and antioxidant properties that protect skin from photodamage and improve anti-aging properties of skin cells. After UV

exposure, treatment with soybean extract results in increased catalase activity, which normally converts hydrogen peroxide to water and oxygen and circumvents its conversion to reactive oxygen species in the cell. Moreover, the expression of cyclooxygenase (COX), an enzyme involved in the production of inflammatory prostaglandins, also increases after UV irradiation. COX expression is significantly decreased in skin pretreated with soybean extract. Finally, soybean extract also decreases the level of proliferating cell nuclear antigen (PCNA), a marker for DNA damage, in skin cells after UV irradiation. As a result, soybean extract targets cellular enzymes to prevent keratinocyte apoptosis, decreases trans-epidermal water loss and the level of inflammation to protect from skin damage due to photoaging.¹¹⁹ Soybean protein has also been shown to inhibit the formation of skin proteinases and increase trichoblast and atrichoblast numbers in skin.⁷³

Soybean protein is frequently used to counter skin aging in moisturizers, cleansers, and hair strengtheners. In clinical trials, soybean has been shown to increase papillae index of skin, fibrillogenesis, and the production of GAGs in the ECM.^{120,121} Soy-derived serine protease inhibitors have also been clinically used to treat hyperpigmentation. This occurs by inhibition of enzymes that mediate keratinocyte phagocytosis of melanosomes.¹²² Scientists have also recently discovered that fermentation of soybean extract produces additional peptides that aid in the *in vivo* inhibition of enzymes involved with lipid peroxidation of cells.¹²³

Rice Peptides

Rice proteins have been well documented for their antioxidative properties and bioactive components that improve the ECM. Hyaluronic acid is a long unbranched polysaccharide component of the ECM. Endogenously, it is synthesized by three types of hyaluronan synthases (HS). Black rice hydrolyzed peptides have been shown to increase HS expression in keratinocytes in a dose-dependent manner. These rice-derived proteins, termed Cohibin, also inhibit MMP activity in keratinocytes.¹²⁴ Moreover, exogenous rice wine can decrease homocysteine-induced MMP production in cells.¹²⁵ In addition, germinated brown rice has antioxidant properties and can block cell cycle re-entry as well as cell apoptosis.¹²⁶ Exogenous hyaluronan can also induce the activity of HS, modifying and strengthening the ECM organization and function. These molecules stimulate angiogenesis, stimulate skin cell proliferation, and induce collagen I formation and collagen IV break down to promote scarless healing.¹²⁷

In one recent clinical study, rice bran extracts were entrapped in niosomes and created into gel and cream formulations. The gel and cream were not irritating, and showed no sign of erythema or edema on the skin of shaved rabbits. The use of these rice-based cosmeceuticals on 30 volunteers resulted in a thicker epidermis in a majority of them, and skin lightening, more elasticity, and improvement of roughness in a minority of the study group.¹²⁸

Acetyl Tetrapeptides

Acetyl tetrapeptide-5 is an acetyl oligopeptide whose role is to inhibit collagen glycation and increase vascular permeability in a dose-dependent manner. This prevents liquid accumulation under the eyes and decreases eye puffiness, as well as improving skin elasticity. Two studies showed that acetyl tetrapeptide-5 reduced under-eye puffiness and discoloration.¹²⁹

Silk Protein

The silkworm *Bombyx mori* secretes two silk proteins: silk fibroin and silk sericin. These are secreted in a non-sericin substance. Silk fibrin is known for its immune tolerance, and is notable for its historic use in suturing. At first, silk sericin was considered an impurity that elicited harmful pro-inflammatory cytokine production.¹³⁰ However, it was recently discovered that silk sericin has numerous beneficial biological activities as an antioxidant and a tyrosinase inhibitor. Tyrosinases catalyze the hydroxylation of monophenol molecules in cells, turning them into ortho-quinones.¹³¹ Silk sericin chelates with copper and prevents lipid peroxidation due to tyrosinase activity, which prevents keratinocyte apoptosis. Antioxidant effects and inhibitory effects on tyrosinase were also recently discovered to be found in the

non-protein layer of silkworms, which consists of carbohydrates, salt, wax, and flavonoid derivatives.¹³² Recently, fibrin and sericin from silkworm was also shown to stimulate cell migration in mink lung epithelial cells.¹³³ The silk protein of a tropical tasar silkworm was found to inhibit UVB-induced apoptosis in human keratinocytes by preventing the activation of caspase-3.¹³⁴

Anti-aging effects of silk sericin have been demonstrated in a within-patient untreated-controlled study. A hydroxyproline assay showed no significant differences in hydroxyproline content, skin impedance, and transepidermal water loss between sericin treated skin and control.¹³⁵ Another study showed a significant drop in impedance when silk fibrin and sericin was used at 5% concentrations.¹³⁶

Silk sericin is also being explored in wound healing applications. A silk sericin-releasing bioactive wound dressing was developed and found on average to heal faster, in 12 days, compared to Bactigras dressing, which healed in 14 days with significantly reduced pain.¹³⁷

Topical Neurotransmitter Inhibitor Peptides

Acetyl Peptide Neurotransmitter Inhibitors

Continuous physiological stimulation of muscles in the face is one of the factors leading to increased wrinkles in aged skin. By inhibiting the activity of innervating neurons, downregulation of muscle activity could lead to a decrease in wrinkles. Botulinum toxin (Btx) has been used in this regard. Btx specifically targets soluble N-ethylmaleimide-sensitive factor attachment protein receptors (SNAREs) and prevents their activity in releasing neurotransmitters. Although Btx has shown efficacy in clearing facial wrinkles, it has a high toxicity and has to be used with strict medical protocols, limiting its topical or at-home use. Instead, peptides with lower toxicity that mimic botulinum toxin's effects on muscles can be used topically. Argireline is a synthetic oligopeptide that emulates the sequence of SNAP-25, a type of SNARE. It has significant skin permeation, interferes with the SNARE ternary complex, and has demonstrated interference with catecholamine release from chromaffin cells. Topical use of 10% argireline resulted in a reduced depth and roughness of periorbital wrinkles in 10 healthy women.¹³⁸ One study on 14 volunteers showed that 5% argireline reduced periorbital wrinkles by 32% in 28 days.⁷³ Most recently, argireline's efficacy has been measured in 60 Chinese women from a randomized control trial. Its total efficacy was 48.9% compared to 0% in the placebo group, and resulted in significantly decreased wrinkle roughness.¹³⁹

Another oligopeptide that interferes with the SNARE function in the cell is acetyl octapeptide-3 (SNAP-8). This peptide, an elongated version of argireline, showed a similar efficacy in reducing wrinkles. In one study that used 10% acetyl octapeptide-3 topically, after 28 days periorbital wrinkles were significantly reduced by nearly 35%.⁷³

Pentapeptides and Tripeptide-3

Pentapeptide 18, also called leuphasyl, limits catecholamine and acetylcholine release by mimicking the effects of enkephalin on the extracellular enkephalin receptors of nerve cells. The subsequent activation of inhibitory G protein coupled receptors results in a decrease of the neuronal cell's excitability and the prevention of neurotransmitter release. *In vitro* studies have shown this effect on glutamate from neurons. One active controlled trial compared 5% leuphasyl solution to 5% argireline and a combination of 5% leuphasyl and 5% argireline. This study showed comparable effects of these two drugs on wrinkles when used singly, and when used together, they resulted in a synergistic and more powerful reduction of wrinkles.

Pentapeptide-3, or Vialox, is a synthetic peptide that acts on a different part of the neuromuscular junction. As a competitive antagonist at nicotinic acetylcholine receptors, Vialox prevents the sodium influx required for muscle fibers to depolarize and contract. Within one minute of treatment, muscle contractions can be reduced by up to 71%, and 58% of muscle fibers are still immotile two hours later. Vialox can prevent wrinkles from getting deeper due to muscle contractions. In one study, Vialox used twice a day for 28 days resulted in a nearly 50% reduction in wrinkle depth and roughness. It can be used at concentrations of 0.05%–0.3% to treat facial wrinkles and tighten skin.

Wagerlin-1 is a neurotoxin produced in the venom of temple vipers, *Tropidolaemus wagleri*. This neurotoxin also binds reversibly to nicotinic acetylcholine receptors at the neuromuscular junction, preventing depolarization and contraction of the muscle. Tripeptide-3 is an oligopeptide that mimics the role of Wagerlin-1 on the neuromuscular junction at a 0.5 millimolar concentration, reducing muscle contractions by 82% after two hours of treatment. Tripeptide-3 is composed of beta-Ala-Pro-Dab-NH-benzyl x2 AcOH, and is also called Syn-Ake. *In vivo* studies demonstrated nearly a 50% decrease in wrinkle size after 28 days of treatment with 4% Tripeptide-3 applied to the face twice daily. Wrinkle reduction was greatest on the forehead.^{17,73}

Conclusions

In conclusion, there are four types of cosmeceutical anti-aging peptides and proteins: carrier, signal, enzyme inhibitors, and neurotransmitter inhibitors. These proteins use various mechanisms to increase collagen synthesis in the skin, help skin cells proliferate, form ECPs such as GAGs to strengthen the ECM, and protect against UV light or reverse its effects. Many of these peptides are as efficacious as tretinoin, with much less skin irritation. However, a substantial amount of topical peptides presented in this chapter require more research in permeation ability, especially in aged skin, and need to be better characterized with randomized double-blind controlled trials to measure their abilities to decrease wrinkles, increase skin elasticity, and treat other effects of aging on their target populations.

REFERENCES

1. U.S. Census Bureau. *The Next Four Decades, The Older Population in the United States: 2010 to 2050*. 2010. p. 1.
2. Gupta MA, Gilchrist BA. Psychosocial aspects of aging skin. *Dermatol Clin* 2005;23(4):643–8.
3. Puig A, Anton JM, Mangles M. A new decorin-like tetrapeptide for optimal organization of collagen fibres. *International Journal of Cosmetic Science* 2008;30(2):97–104.
4. Visse R, Nagase H. Matrix metalloproteinases and tissue inhibitors of metalloproteinases: Structure, function, and biochemistry. *Circ Res* 2003;92:827–39.
5. Pillai S, Oresajo C, Hayward J. Ultraviolet radiation and skin aging: Roles of reactive oxygen species, inflammation and protease activation, and strategies for prevention of inflammation-induced matrix degradation. *Int J Cosmet Sci* 2005;27:17–34.
6. Andrews SN, Jeong E, Prausnitz MR. Transdermal delivery of molecules is limited by full epidermis, not just stratum corneum. *Pharm Res* 30(4):1099–9.
7. Pouillot A, Dayan N, Polla A et al. The stratum corneum: A double paradox. *Journal of Cosmetic Dermatology* 2008;7:143–8.
8. El Maghraby GM, Barry BW, Williams AC. Liposomes and skin: From drug delivery to model membranes. *European Journal of Pharmaceutical Sciences* 2008;34(4–5):203–2.
9. Farage MA, Miller KW, Maibach HI. *Textbook of Aging Skin*. Berlin Heidelberg: Springer; 2010.
10. Roberts MS, Pellett MA. Skin transport. Walters AW, ed. *Dermatological and Transdermal Formations*, New York: Dekker; 2002. p. 121.
11. Guy RH. Current status and future prospects of transdermal drug delivery. *Pharm Res* 1996;13:1765–9.
12. Vecchia BE, Bunge AL. *Evaluating the Transdermal Permeability of Chemicals*. New York: Dekker; 2003.
13. Potts RO, Guy RH. Predicting skin permeability. *Pharmaceut Res* 1992;9(5):663–9.
14. Smith EW, Maibach HI. *Percutaneous Penetration Enhancers*. New York: Taylor & Francis Group; 2006.
15. Chen Y, Shen Y, Guo X et al. Transdermal protein delivery by a coadministered peptide identified via phage display. *Nat Biotechnol* 2006;24:455–60.
16. Foldvari M, Attah-Poku S, Hu J et al. Palmitoyl derivatives of interferon alpha: Potential for cutaneous delivery. *J Pharm Sci* 1998;87:1203–8.
17. Reddy B, Jow T, Hantash BM. Bioactive oligopeptides in dermatology: Part II. *Experimental Dermatology* 2012;21:569–75.

18. Kastin AJ, Arimura A, Schally AV. Topical absorption of polypeptides with dimethylsulfoxide. *Arch Dermatol* 1966;93:471–3.
19. Ruland A, Kreuter J. Transdermal permeability and skin accumulation of amino acids. *Int J Pharm* 1991;72:149–55.
20. Mazurowska L, Norwak-Buciak K, Mojski M. ESI-MS method for in vitro investigation of skin penetration by copper-amino acid complexes: From an emulsion through a model membrane. *Anal Bioanal Chem* 2007;388:1157–63.
21. Goebel A, Neubert RH. Dermal peptide delivery using colloidal carrier systems. *Skin Pharmacol Physiol*. 2008;21:3–9.
22. Borcan F, Soica CM, Dehelean CA et al. Size and stability optimization for polyurethane nanostructures used as transdermal drug vehicle. *Rev Chim Bucharest* 2012;7(11):1164–6.
23. Pando D, Caddeo C, Manconi M et al. Nanodesign of olein vesicles for the topical delivery of the antioxidant resveratrol. *J Pharm Pharmacol* 2013;65(8):1158–67.
24. Manca ML, Zaru M, Manconi M et al. Glycerosomes: A new tool for effective dermal and transdermal drug delivery. *Int J Pharm* 2013;455(1–2):66–74.
25. Haenssle HA, Riedl P, Buhl T et al. Intracellular delivery of major histocompatibility complex class I-binding epitopes: Dendritic cells loaded and matured with cationic peptide/poly(L:C) complexes efficiently activate T cells. *Experimental Dermatology* 2010;19:19–28.
26. Antosova Z, Mackova M, Kral V et al. Therapeutic application of peptides and proteins: Parenteral forever? *Trends Biotechnol* 2009;27(11):628–35.
27. Dudelzak J, Hussain M, Phelps RG et al. Evaluation of histologic and electron microscopic changes after novel treatment using combined microdermabrasion and ultrasound-induced phonophoresis of human skin. *J Cosmet Laser Ther* 2008;10(4):187–92.
28. Rachaonda VK, Yerramsetty KM, Madihally SV et al. Screening of chemical penetration enhancers for transdermal drug delivery using electrical resistance of skin. *Pharm Res* 2008;25(11):2697–704.
29. Kim KW, Kim KS, Kim H et al. Terahertz dynamic imaging of skin drug absorption. *Opt Express* 2012;20(9):9476–84.
30. Popa I, Abdul-Malak N, Portoukalian J. The weak rate of sphingolipid biosynthesis shown by keratinocytes isolated from aged vs. young donors is fully rejuvenated after treatment with peptides of a potato hydrolysate. *International Journal of Cosmetic Science* 2009;32:225–32.
31. Pickart L, Thayer L, Thaler M. Synthetic tripeptide which increases survival of normal liver cells, and stimulates growth of hepatoma cells. *Biochem Biophys Res Commun* 1973;54:562–6.
32. Grosse G, Linder G. Experimental influence of pharmacological agents on the regeneration of nervous tissue in vitro. *Folia Morphol (Praha)* 1980;28(4):345–7.
33. Poole T, Zetter, BR. Stimulation of rat peritoneal mast cell migration by tumor-derived peptides. *Cancer Res* 1983;43:5857–61.
34. Pickart L. Lamin: A growth factor with multiple wound-healing properties. In: Sorensen J (ed.). *Biology of Copper Complexes*. Clifton: Humana Press, 1987, pp. 273–82.
35. Gruchlik A, Chodurek E, Dzierzewicz Z. Influence of selected peptides and their copper complexes on antioxidant enzyme activities in human skin fibroblasts. *Postepy Dermatologii i Alergologii* 2010;27(1):29–35.
36. Simeon A, Emonard H, Hornebeck W et al. The tripeptide–copper complex glycyl-L-histidyl-L-lysine stimulates matrix metalloproteinase-2 expression by fibroblast cultures. *Life Sci* 2000;67(18):2257–65.
37. Le NT, Xue M, Castelnoble LA et al. The dual personalities of matrix metalloproteinases in inflammation. *Front Biosci* 2007;12:1475–87.
38. Simeon A, Wegrowski Y, Bontemps Y et al. Expression of glycosaminoglycans and small proteoglycans in wounds: Modulation by the tripeptide-copper complex glycyl-L-histidyl-L-lysine-Cu(2+). *J Invest Dermatol* 2000;115:962–8.
39. Bianco P, Fisher L, Young M et al. Expression and localization of the two small proteoglycans biglycan and decorin in developing human skeletal and non-skeletal tissues. *J Histochem Cytochem* 1990;38:1549–63.
40. Maquart FX, Bellon G, Chaquour B et al. In vivo stimulation of connective tissue accumulation by the tripeptide-copper complex glycyl-L-histidyl-L-lysine in rat experimental wounds. *J Clin Invest* 1993;92:2368–76.

41. Pollard JD, Quan S, Kang T et al. Effects of copper tripeptide on the growth and expression of growth factors by oral and irradiated fibroblasts. *Arch Facial Plast Surg* 2005;7:27–31.
42. Gruchlik A, Jurzak M, Chodurek EW et al. Effect of Gly-Gly-His, Gly-His-Lys and their copper complexes on TNF- α -dependent IL-6 secretion in normal human dermal fibroblasts. *Acta Poloniae Pharmaceutica—Drug Researc* 2012;69(6):1303–6.
43. Jurij J, Hostynek FD, Maibach HI. Human skin retention and penetration of a copper tripeptide in vitro as function of skin layer towards anti-inflammatory therapy. *Inflamm Res* 2010;59(11):983–8.
44. Noah P, Parker Ardeshirpour F et al. Effects of topical copper tripeptide complex on wound healing in an irradiated rat model. *Otolaryngol Head Neck Surg* 2013;149(3):384–9.
45. Mazurowska L, Mojski M. ESI-MS study of the mechanism of glycyl-l-histidyl-l-lysine-Cu(II) complex transport through model membrane of stratum corneum. *Talanta* 2007;72(2):650–4.
46. Mazurowska L, Mojski M. Biological activities of selected peptides: Skin penetration ability of copper complexes with peptide. *J Cosmet Sci* 2008;59:59–69.
47. Choi HR, Kang YA, Ryoo SJ et al. Stem cell recovering effect of copper-free GHK in skin. *Journal of Peptide Science* 2012;18(11):685–90.
48. Raluca-Ioana C, Chaimbault P, Archambault JC. Development of a LC–MS/MS method to monitor palmitoyl peptides content in anti-wrinkle cosmetics. *Analytica Chimica Acta* 2009;641(1–2):95–100.
49. Abdulghani AA, Sherr A, Shirin S et al. Effects of topical creams containing vitamin C, a copper-binding peptide cream and melatonin compared with tretinoin on the ultrastructure of normal skin. *Dis Manage Clin Outcomes* 1998;1:136–41.
50. Litner K. Promoting production in the extracellular matrix without compromising barrier. *Cutis* 2002;70:13–6.
51. American Academy of Dermatology. A clinical evaluation of a copper-peptide-containing liquid foundation and cream concealer designed for improving skin condition [press release]. *American Academy of Dermatology 60th Annual Meeting* 2002.
52. Hou YW, Chan MH, Hsu HR et al. Transdermal delivery of proteins mediated by non-covalently associated arginine-rich intracellular delivery of peptides. *Exp Dermatol* 2007;16:999–1006.
53. Finkey MB, Appa Y, Bhandarkar S. Copper peptide and skin. In: P. Elsner aHIM, eds. *Cosmeceuticals and Active Cosmetics*. New York, NY: Marcel Dekker; 2005. p. 549–64.
54. Leyden JJ. *Skin Care Benefits of Copper Peptide Containing Facial Cream [Press Release]*. New Orleans, LA, USA.
55. Kalyanaraman B. Teaching the basics of redox biology to medical and graduate students: Oxidants, anti-oxidants and disease mechanisms. *Redox Biol* 2013;1(1):244–57.
56. Naderi-Hachtroudi L, Peters T, Brenneisen P et al. Induction of manganese superoxide dismutase in human dermal fibroblasts: A UV-B-mediated paracrine mechanism with the release of epidermal interleukin 1(alpha), interleukin 1(beta), and tumor necrosis factor (alpha). *Archives of Dermatology* 2002;138:1473–9.
57. Mussarrat H, Goldberg DJ. Topical manganese peptide in the treatment of photodamaged skin. *Journal of Cosmetic and Laser Therapy* 2007;9(4):232–6.
58. Abu Samah NH, Heard CM. Topically applied KTTS: A Review. *Int J Cosmet Sci* 2011;33(6):483–90.
59. Park EJ, Kim MS, Choi YL et al. Liquid chromatography–tandem mass spectrometry to determine the stability of collagen pentapeptide (KTTKS) in rat skin. *Journal of Chromatography B* 2012;905:113–7.
60. Katayama K, Seyer JM, Raghov R et al. Regulation of extracellular matrix production by chemically synthesized subfragments of type I collagen carboxy propeptide. *Biochemistry* 1991;30(29):7097–8104.
61. Wen-Chung Tsai C-CH, Chia-Ying Chung, Miao-Sui Lin, Sung-Lung Li, Jong-Hwei S. Pang. The pentapeptide KTTKS promoting the expressions of type I collagen and transforming growth factor-b of tendon cells. *Journal of Orthopaedic Research* 2007;25(12):1629–34.
62. James L. Improved appearance of facial wrinkles with use of a cosmetic moisturizer containing olive derivative, dill seed extract, Pal-KTTKS, and niacinamide. *Journal of the American Academy of Dermatology* 2013;68(4):AB30.
63. Kaczvinsky JR, Griffiths CE, Schnicker MS et al. Efficacy of anti-aging products for periorbital wrinkles as measured by 3-D imaging. *Journal of Cosmetic Dermatology* 2009;8(3):228–33.
64. Roanne RJ, Castelletto V, Connon CJ et al. Collagen stimulating effect of peptide amphiphile C16–KTTKS on human fibroblasts. *Langmuir* 2013;29(16):5050–9.

65. Osborne R, Carver RS, Mullins LS et al. Practical application of cellular bioenergetics to the care of aged skin. *British Journal of Dermatology* 2013;169(s2):32–8.
66. Navarini A, Allemann IB, Calvo X. Evidence-based topical skin rejuvenation. *Journal of the American Academy of Dermatology* 2013;64(2):AB70.
67. Choi HP, Park J, Kim H et al. A novel L-ascorbic acid and peptide conjugate with increased stability and collagen biosynthesis. *BMB Rep* 2009;42:743–6.
68. Sweetwyne MT, Murphy-Ullrich JE. Thrombospondin1 in tissue repair and fibrosis: TGF- β -dependent and independent mechanisms. *Matrix Biol* 2012;31(3):178–86.
69. Cauchard JH, Godeau G, Hornebeck W, Bellon G. Activation of latent transforming growth factor beta 1 and inhibition of matrix metalloprotease activity by a thrombospondin-like tripeptide linked to elaidic acid. *Biochem Pharmacol* 2004;67(11):2013–2.
70. Pentapharm. Syn-Coll Basel/Switzerland. Available from: <http://wrinklesystem.com/laboratorydata/Syn-Coll.pdf>.
71. Rodier FCJ. Four faces of cellular senescence. *The Journal of Cell Biology* 2011;192(4):547–6.
72. Gruber JV1, Ludwig P, Holtz R. Modulation of cellular senescence in fibroblasts and dermal papillae cells in vitro. *Journal of Cosmetic Science* 2013;64(2):79–87.
73. Gorouhi FMH. Role of topical peptides in preventing or treating aged skin. *Int J Cosmet Sci* 2008;31(5):327–45.
74. Inc GI. Granactive AGE Elmwood Park, NJ. Available from: http://www.grantinc.com/cosmetics/active_series/granactive_age.php.
75. Fields KFT, Rodan K et al. Bioactive peptides: Signaling the Future. *Journal of Cosmetic Dermatology* 2009;8(1):8–13.
76. Gaudron S1, Adeline MT, Potier P, Thierry J. NAcSDKP analogues resistant to angiotensin-converting enzyme. *J Med Chem* 1997;40:3963–8.
77. Kanasaki M, Nagai T, Kitada M et al. Elevation of the antifibrotic peptide N-acetyl-seryl-aspartyl-lysyl-proline: A blood pressure-independent beneficial effect of angiotensin I-converting enzyme inhibitors. *Fibrogenesis & Tissue Repair* 2011;4:25.
78. Hajem N, Chapelle A, Bignon J et al. The regulatory role of the tetrapeptide AcSDKP in skin and hair physiology and the prevention of ageing effects in these tissues—A potential cosmetic role. *Int J Cosmet Sci* 2013;35(3):286–98.
79. Hajem N, Chapelle A, Bignon J et al. The regulatory role of the tetrapeptide AcSDKP in skin and hair physiology and the prevention of ageing effects in these tissues—A potential cosmetic role. *Int J Cosmet Sci* 2013;35(3):286–98.
80. Pauly G, Contet-Audonneau J, Moussou P et al. Small proteoglycans in the skin: New targets in the fight against aging. *IFSCC* 2008;11:21–9.
81. Rattan S, Clark B. Kinetin delays the onset of aging characteristics in human fibroblasts. *Biochemical and Biophysical Research Communications* 1994;201(2):665–72.
82. Berge U, Kristensen P, Rattan SI. Kinetin-induced differentiation of normal human keratinocytes undergoing aging in vitro. *Ann NY Acad Sci* 2006;1067:332–6.
83. Kimura T, Doi K. Depigmentation and rejuvenation effects of kinetin on the aged skin of hairless descendants of Mexican hairless dogs. *Rejuvenation Res* 2004;7(1):32–9.
84. Katz BE, Bruck MC. Efficacy and tolerability of kinetin 0.1% cream for improving the signs of photoaging in facial and neck skin. *Cosmetic Dermatology* 2006;19(12):735–41.
85. Chiu PC, Chan CC, Lin HM. The clinical anti-aging effects of topical kinetin and niacinamide in Asians: A randomized, double-blind, placebo-controlled, split-face comparative trial. *J Cosmet Dermatol* 2007;6(4):243–9.
86. Popescu L, Fernandez JR, Stock JB et al. Prevege® blend of cosmetic functional ingredients counteracts skin aging by providing anti-oxidant and anti-inflammatory protection. *Journal of Investigative Dermatology* 2013;133:S17–S55.
87. McCullough JL, Garcia RL, Reece B. A clinical study of topical Pyratine 6 for improving the appearance of photodamaged skin. *J Drugs Dermatol* 2008;7(2):131–5.
88. Tremaine AM, Ortiz A, Elkeeb L et al. Long-term efficacy and safety of topical PRK 124 (0.125%) lotion (Pyratine-XR) in the treatment of mild-to-moderate rosacea. *J Drugs Dermatol* 2010;9(6):647–50.

89. Kleszczynski K, Kruse N, Zillikens D et al. Melatonin activates the transcription factor Nrf2 and phase-2 antioxidant enzymes in UV-irradiated human keratinocytes. *Experimental Dermatology* 2013;22(3):e19.
90. Kim TK, Kleszczynski K, Janjetovic Z et al. Metabolism of melatonin and biological activity of intermediates of melatonergic pathway in human skin cells. *The Journal of the Federation of American Societies for Experimental Biology* 2013;27(7):2742–55.
91. Kleszczynski K, Tukaj S, Zillikens D et al. Melatonin counteracts UVR-induced up-regulation of HSP70 expression in human ex vivo skin. *Experimental Dermatology* 2013;22(3):e19.
92. Rezzani R, Rodella LF, Favero G et al. Attenuation of UVA-induced alterations in NIH3T3 dermal fibroblasts by melatonin. *Br J Dermatol* 2014;170(2):382–91.
93. Kleszczynski K, Fischer TW. Melatonin and human skin. *Dermato-Endocrinology* 2012;4(3):245–52.
94. Fisher TW, Scholz G, Knol B et al. Suppression of UV induced erythema by topical treatment with melatonin. *Biol Signal Recept* 1999;8:132–5.
95. Sierra A, Garduño Ramírez ML, Calpena Campmany AC et al. In vivo and in vitro evaluation of the use of a newly developed melatonin loaded emulsion combined with UV filters as a protective agent against skin irradiation. *Journal of Dermatological Science* 2013;69(3):202–14.
96. Zaba LC, Krueger JG, Lowes MA. Resident and “inflammatory” dendritic cells in human skin. *Journal of Investigative Dermatology* 2008;129:302–8.
97. Yang MF, Baron ED. Update on the immunology of UV and visible radiation therapy: Phototherapy, photochemotherapy and photodynamic therapy. *Expert Review of Dermatology* 2008;3(1):85–98.
98. Ghersetich I, Lotti T. Alpha-Interferon cream restores decreased levels of Langerhans/indeterminate (CD1a+) cells in aged and PUVA-treated skin. *Skin Pharmacol* 1994;7(3):118–20.
99. Shirakata Y. Regulation of epidermal keratinocytes by growth factors. *Journal of Dermatological Science* 2010;59(2):73–80.
100. Lewis C, Mardaryev AN, Sharov AA et al. Bone morphogenetic protein signalling regulates keratinocyte proliferation and migration during wound healing in murine and human skin. *Journal of Investigative Dermatology* 2013;133(Suppl 1):S258.
101. Nakamizo S, Egawa G, Doi H et al. Basic fibroblast growth factor stimulation of skin barrier recovery. *Journal of Investigative Dermatology* 2011;131(Suppl 2):S5.
102. Kwon YB, Kim HW, Roh DH et al. Topical application of epidermal growth factor accelerates wound healing by myofibroblast proliferation and collagen synthesis in rat. *Journal of Veterinary Science* 2006;7(2):105–9.
103. Pasonen-Seppänen S, Karvinen S, Törrönen K et al. EGF upregulates, whereas TGF- β downregulates, the hyaluronan synthases Has2 and Has3 in organotypic keratinocyte cultures: Correlations with epidermal proliferation and differentiation. *Journal of Investigative Dermatology* 2003;120:1038–44.
104. Unterluggauer H, Micutkova L, Lindner H et al. Identification of Hsc70 as target for AGE modification in senescent human fibroblasts. *Biogerontology* 2008;10(3):299–309.
105. Lohwasser C, Neureiter D, Weigle B et al. The receptor for advanced glycation end products is highly expressed in the skin and upregulated by advanced glycation end products and tumor necrosis factor- α . *Journal of Investigative Dermatology* 2006;126:291–9.
106. Zhang L, Pelech S, Uitto VJ. Bacterial GroEL-like heat shock protein 60 protects epithelial cells from stress-induced death through activation of ERK and inhibition of caspase 3. *Exp Cell Res* 2004;292(1):231–40.
107. Zhang L, Koivisto L, Heino J et al. Bacterial heat shock protein 60 may increase epithelial cell migration through activation of MAP kinases and inhibition of α 6 β 4 integrin expression. *Biochem Biophys Res Commun* 2004;319(4):1088–95.
108. Morris SD. Heat shock proteins and the skin. *Clin Exp Dermatol* 2002;27(3):220–4.
109. Volloch V, Rits S. A natural extracellular factor that induces Hsp72, inhibits apoptosis, and restores stress resistance in aged human cells. *Exp Cell Res* 1999;253(2):483–92.
110. Cucumel K, Dal Farra C, Domloge N. Artemia extract “compensates” for age-related decrease of Hsp70 in skin. *J Invest Dermatol* 2002;119:257.
111. Choi SH, Kim SY, An JJ et al. Human PEP-1-ribosomal protein S3 protects against UV-induced skin cell death. *FEBS Letters* 2006;580(30):6755–62.
112. Ahn EH, Kim DW, Kang HW et al. Transduced PEP-1-ribosomal protein S3 (rpS3) ameliorates 12-O-tetradecanoylphorbol-13-acetate-induced inflammation in mice. *Toxicology* 2010;44(5):329–34.

113. Haines RL, Lane EB. Keratins and disease at a glance. *Journal of Cell Science*. 2013;125:3923–8.
114. Tang L, Sierra JO, Kelly R et al. Wool-derived keratin stimulates human keratinocyte migration and types IV and VII collagen expression. *Experimental Dermatology* 2012;21(6):458–60.
115. Than MP, Smith RA, Cassidy S et al. Use of a keratin-based hydrogel in the management of recessive dystrophic epidermolysis bullosa. *Journal of Dermatologic Treatment* 2013;24(4):290–1.
116. Barba C, Mendez S, Roddick-Lanzilotta A et al. Wool peptide derivatives for hand care. *J Cosmet Sci* 2007;58:99–107.
117. Barba C, Mendez S, Roddick-Lanzilotta A et al. Cosmetic effectiveness of topically applied hydrolysed keratin peptides and lipids derived from wool. *Skin Res Technol* 2008;14:243–348.
118. dal Farra C, Oberto G, Berghi A et al. An anti-aging effect on the lips and skin observed in in vivo studies on a new fibronectin-like peptide. *J Am Acad Dermatol* 2007;2007(56):AB88.
119. Huang CC, Hsu BY, Wu NL et al. Anti-photoaging effects of soy isoflavone extract (aglycone and acetylglucoside form) from soybean cake. *Int J Mol Sci* 2010;11(12):4782–5.
120. Andre-Frei V, Perrier E, Augustin C et al. A comparison of biological activities of a new soya biopeptide studied in an in vitro skin equivalent model and human volunteers. *Int J Cosmet Sci* 1999;21:299–311.
121. Sudel KM, Venzke K, Mielke H et al. Novel aspects of intrinsic and extrinsic aging of human skin: Beneficial effects of soy extract. *Photochem Photobiol* 2005;81:581–7.
122. Leyden J, Wallo W. The mechanism of action and clinical benefits of soy for the treatment of hyperpigmentation. *Pharmacology of Therapeutics* 2011;50(4):470–7.
123. Sandra R, Georgetti RC, Vicentini FT. Protective effect of fermented soybean dried extracts against TPA-induced oxidative stress in hairless mice skin. *Biomed Reserach International* 2013;Article ID 340626.
124. Sim GS, Lee DH, Kim JH et al. Black rice (*Oryza sativa* L. var. japonica) hydrolyzed peptides induce expression of hyaluronan synthase 2 gene in HaCaT keratinocytes. *Journal of Microbiology and Biotechnology* 2007;17(2):271–9.
125. Ji Z, Guo HY, Chi JF et al. Effects of homocysteine-induced MMP-2 in rat vascular endothelial cells and the reverse effect of rice wine and red wine and its mechanisms. *Journal of Xi'an Jiaotong University (Medical Sciences)* 2013;34(3):313–9.
126. Ismail N, Ismail M, Fathy SF et al. Neuroprotective effects of germinated brown rice against hydrogen peroxide induced cell death in human SH-SY5Y cells. *Int J of Molecular Sci* 2012;13(8):9692–708.
127. Allison DD, Braun KR, Wight TN et al. Differential effects of exogenous and endogenous hyaluronan on contraction and strength of collagen gels. *Acta Biomaterialia* 2009;5(4):1019–26.
128. Manosroi A, Chutoprapat R, Abe M et al. Anti-aging efficacy of topical formulations containing niosomes entrapped with rice bran bioactive compounds. *Pharmaceutical Biology* 2012;50(2):208–24.
129. Lipotec. EYESERYL® SOLUTION. Bhttp://www.theherbarie.com/files/resource-center/tds/TDS_Eyeseryl_SolutionB.pdf. Last accessed April 4, 2015.
130. Panilaitis B, Altman GH, Chen J et al. Macrophage responses to silk. *Biomaterials* 2003;24(18):3079–85.
131. Aramwit P, Damrongsakkul S, Kanokpanont S et al. Properties and antityrosinase activity of sericin from various extraction methods. *Biotechnology and Applied Biochemistry* 2010;55(2):91–8.
132. Wang HY, Wang YJ, Zhou LX et al. Isolation and bioactivities of a non-sericin component from cocoon shell silk sericin of the silkworm *Bombyx mori*. *Food & Function* 2012;3(2):150–8.
133. Martínez-Mora C, Mrowiec A, García-Vizcaíno EM et al. Fibroin and sericin from *Bombyx mori* silk stimulate cell migration through upregulation and phosphorylation of c-jun. *PLoS One* 2012;7(7):e42271.
134. Dash R, Mandal M, Ghosh SK et al. Silk sericin protein of tropical tasar silkworm inhibits UVB-induced apoptosis in human skin keratinocytes. *Molecular and Cellular Biochemistry* 2008;311(1–2):111–9.
135. Padamwar MN, Pawar AP, Daithankar AV et al. Silk sericin as a moisturizer: An in vivo study. *J Cosmet Dermatol* 2005;4:250–7.
136. Daithankar AV, Padamwar MN, Pisal SS. Moisturizing efficiency of silk protein hydrolysate: Silk fibroin. *Indian J Biotechnol* 2005;4:115–21.
137. Siritientong T, Angspatt A, Ratanavaporn J et al. Clinical potential of a silk sericin-releasing bioactive wound dressing for the treatment of split-thickness skin graft donor sites. *Pharm Res* 2014;31(1):104–16.
138. Blanes-Mira C, Clemente J, Jodas G et al. A synthetic hexapeptide (Argireline) with antiwrinkle activity. *Int J Cosmet Sci* 2002;24(5):303–10.
139. Wang Y, Wang M, Xiao S et al. The anti-wrinkle efficacy of argireline, a synthetic hexapeptide, in Chinese subjects: A randomized, placebo-controlled study. *Am J Clin Dermatol* 2013;14(2):147–53.

140. Mazurowska L, Mojski M. Biological activities of selected peptides: Skin penetration ability of copper complexes with peptides. *J Cosmet Sci* 2008;59(1):59–69.
141. Ruland A, Kreuter J. Transdermal permeability and skin accumulation of amino acids. *International Journal of Pharmaceutics* 1991;72(2):149–55.
142. Mazurowska L, Nowak-Buciak K, Mojski M. ESI-MS method for in vitro investigation of skin penetration by copper-amino acid complexes: From an emulsion through a model membrane. *Anal Bioanal Chem* 2007;388(5–6):1157–63.
143. Ruland A, Kreuter J, Rytting JH. Transdermal delivery of the tetrapeptide hisetal (melanotropin [6-9]). I. Effect of various penetration enhancers: In vitro study across hairless mouse skin. *International Journal of Pharmaceutics* 1994;101(1–2):57–61.
144. Ruland A, Kreuter J, Rytting JH. Transdermal delivery of the tetrapeptide hisetal (melanotropin [6-9]): II. Effect of various penetration enhancers. In vitro study across human skin. *International Journal of Pharmaceutics* 1994;103(1):77–80.
145. Appa Y, Stephens T, Barkovic S et al. A clinical evaluation of a copper-peptide-containing liquid foundation and cream concealer designed for improving skin condition. *American Academy of Dermatology 60th Annual Meeting*, New Orleans, LA, USA, February 22–27, 2002, p. 28.
146. Leyden JJ, Stevens T, Finkey MB, Barkovic S. Skin care benefits of copper peptide containing facial cream. *American Academy of Dermatology 60th Annual Meeting*, New Orleans, LA, USA, February 22–27, 2002.
147. Leyden JJ, Stevens T, Finkey MB, Barkovic S. Skin care benefits of copper peptide containing eye creams. *American Academy of Dermatology 60th Annual Meeting*, New Orleans, LA, USA, February 22–27, 2002.
148. Finkey MB, Appa Y, Bhandarkar S. Copper peptide and skin. In: Elsner P, Maibach HI, eds. *Cosmeceuticals and Active Cosmetics*, 2nd edition. New York, NY: Marcel Dekker; 2005. p. 549–64.
149. Abdulghani AA, Sherr A, Shirin S et al. Effects of topical creams containing vitamin C, a copper-binding peptide cream and melatonin compared with tretinoin on the ultrastructure of normal skin. *Disease Management and Clinical Outcomes* 1998;1(4):136–41.
150. Robinson LR, Fitzgerald NC, Doughty DG et al. Topical palmitoyl pentapeptide provides improvement in photoaged human facial skin. *Int J Cosmet Sci* 2005;27(3):155–60.
151. Osborne R, Robinson LR, Mullins L, Raleigh P. Use of a facial moisturizer containing palmitoyl pentapeptide improves the appearance of aging skin. *J Am Acad Dermatol* 2005;52(3 Suppl 1):96.
152. Pauly G, Contet-Audonoeau J, Moussou P et al. Small proteoglycans in the skin: New targets in the fight against aging. *IFSCC* 2008;11(1):21–9.
153. Pentapharm. Syn[®]-Coll Basel, Switzerland [cited 2008]. Available from: http://www.ingredientstodiefor.com/files/DATA_Syn-Coll.pdf.
154. dal Farra C, Oberto G, Berghi A, Domloge N. An anti-aging effect on the lips and skin observed in in vivo studies on a new fibronectin-like peptide. *J Am Acad Dermatol* 2007;56(Suppl 2):AB88.
155. Puig A, Anton JMG, Manges M. A new decorin-like tetrapeptide for optimal organization of collagen fibres. *International Journal of Cosmetic Science* 2008;30(2):97–104.
156. ARCH personal care products, Technical information document. PeptamideTM6, A firming hexapeptide South Plainfield, NJ [cited 2008]. Available from: http://www.archchemicals.com/Fed/PC/Docs/Peptamide_6_v1.6.pdf.
157. Dickens MS, Levy SB, Helman MD, Nucci JE. Kinetin containing lotion compared with retinol containing lotion; Comparable improvements in the signs of photoaging. *American Academy of Dermatology 60th Annual Meeting*, New Orleans, LA, USA, February 22–27, 2002, p. 28.
158. Chiu PC, Chan CC, Lin HM, Chiu HC. The clinical anti-aging effects of topical kinetin and niacinamide in Asians: A randomized, double-blind, placebo-controlled, split-face comparative trial. *J Cosmet Dermatol* 2007;6(4):243–9.
159. Kimura T, Doi K. Depigmentation and rejuvenation effects of kinetin on the aged skin of hairless descendants of Mexican hairless dogs. *Rejuvenation Research* 2004;7(1):32–9.
160. Ehrlich M, Rao J, Pabby A, Goldman MP. Improvement in the appearance of wrinkles with topical transforming growth factor beta(1) and l-ascorbic acid. *Dermatol Surg* 2006;32(5):618–25.
161. Gold MH, Goldman MP, Biron J. Human growth factor and cytokine skin cream for facial skin rejuvenation as assessed by 3D in vivo optical skin imaging. *J Drugs Dermatol* 2007;6(10):1018–23.

162. Fischer T, Bangha E, Elsner P, Kistler GS. Suppression of UV-induced erythema by topical treatment with melatonin. Influence of the application time point. *Biological Signals and Receptors* 1999;8(1–2):132–5.
163. Barba C, Mendez S, Roddick-Lanzilotta A et al. Wool peptide derivatives for hand care. *J Cosmet Sci* 2007;58(2):99–107.
164. Barba C, Mendez S, Roddick-Lanzilotta A et al. Cosmetic effectiveness of topically applied hydrolysed keratin peptides and lipids derived from wool. *Skin Res Technol* 2008;14(2):243–8.
165. Sudel KM, Venzke K, Mielke H et al. Novel aspects of intrinsic and extrinsic aging of human skin: Beneficial effects of soy extract. *Photochem Photobiol* 2005;81(3):581–7.
166. Andre-Frei V, Perrier E, Augustin C, Damour O, Bordat P, Schumann K et al. A comparison of biological activities of a new soya biopeptide studied in an in vitro skin equivalent model and human volunteers. *International Journal of Cosmetic Science* 1999;21(5):299–311.
167. Zhaorigetu S, Yanaka N, Sasaki M, Watanabe H, Kato N. Inhibitory effects of silk protein, sericin on UVB-induced acute damage and tumor promotion by reducing oxidative stress in the skin of hairless mouse. *Journal of Photochemistry and Photobiology B: Biology* 2003;71(1–3):11–7.
168. Padamwar MN, Pawar AP, Daithankar AV, Mahadik KR. Silk sericin as a moisturizer: An in vivo study. *Journal of Cosmetic Dermatology*. 2005;4(4):250–7.
169. Daithankar AV, Padamwar MN, Pisal SS, Paradkar AR, Mahadik KR. Moisturizing efficiency of silk protein hydrolysate: Silk fibroin. *Indian Journal of Biotechnology*. 2005;4(1):115–21.
170. Centerchem. Leuphasyl® Barcelona, Spain [cited 2006]. Available from: [http://www.centerchem.com/PDFs/D-Leuphasyl w stamp.pdf](http://www.centerchem.com/PDFs/D-Leuphasyl%20stamp.pdf).
171. Watson RE, Long SP, Bowden JJ et al. Repair of photoaged dermal matrix by topical application of a cosmetic ‘antiageing’ product. *Br J Dermatol* 2008;158(3):472–7.
172. Blanes-Mira C, Clemente J, Jodas G, Gil A, Fernandez-Ballester G, Ponsati B et al. A synthetic hexapeptide (Argireline) with antiwrinkle activity. *Int J Cosmet Sci* 2002;24(5):303–10.
173. Cauchard JH, Berton A, Godeau G, Hornebeck W, Bellon G. Activation of latent transforming growth factor beta 1 and inhibition of matrix metalloprotease activity by a thrombospondin-like tripeptide linked to elaidic acid. *Biochem Pharmacol* 2004;67(11):2013–22.
174. Centerchem. Syn®-Ake Basel, Switzerland [cited 2008]. Available from: [http://www.centerchem.com/PDFs/SYN-TACKS FactSheet 0407.pdf](http://www.centerchem.com/PDFs/SYN-TACKS%20FactSheet%200407.pdf).

15

Amino Acids and Derivatives

Kazutami Sakamoto

Introduction

Amino acids are molecules with both an amino group and carboxylic group. There are 20 kinds of naturally occurring amino acids with optical active structures at α -position (L-amino acids) except glycine. Greenstein and Winitz said: “Few products of natural origin are versatile in their behavior and properties as are the amino acids, and few have such a variety of biological duties to perform” in their preface of *Chemistry of the Amino Acid* in 1961.¹ Subsequently significant progress has been made on the knowledge of amino acids, and technical achievements to utilize such progress are remarkable, including cosmetic and cosmeceutical applications. This is due to the market growth and cost reduction of certain amino acids for many industrial applications. For example, in food applications there is huge and still growing consumption generated for glutamic acid (Glu) and glycine (Gly) as food additives and aspartic acid (Asp) and phenylalanine (Phe) as raw materials for the artificial sweetener “aspartame.” Consumption of lysine (Lys), methionine (Met), and threonine (Thr) is expanding in the animal food additives market. Cysteine (CysH) and proline (Pro) are major amino acids utilized in the flavor industry to manufacture natural flavors by Maillard reaction with sugars. Health food and pharmaceutical intermediates are other rapidly growing markets for many amino acids. In this chapter, the role of amino acids and derivatives are reviewed as functional molecules for cosmeceutical applications.

Amino Acids Basic Features

As stated in *Chemistry of Amino Acids*:¹

Amino acids are at once water soluble and amphoteric electrolytes, with the ability to form acid salts and basic salts and thus act as buffers over at least two range of pH; dipolar ions of high electric moment with a considerable capacity to increase the dielectric constant of the medium in which they are dissolved; compounds with reactive groups capable of a wide range of chemical alterations leading readily to a great variety of degradation, synthetic, and transformation products such as esters, amides, amines, polymers, etc.

Such general features of amino acids are summarized in the tables as follows²: solubility in water (Table 15.1) or aqueous alcohol (Table 15.2), dissociation constants and isoelectric points (Table 15.3), optical rotations (Table 15.4), reactivity (Tables 15.5 and 15.6), and acute oral toxicity (Table 15.7). These properties of amino acids have become of practical importance for cosmetic applications in recent decades. Other driving forces of increasing use of amino acids for cosmetic preparations are consumer’s growing concerns over the environmental and health impacts of the traditional chemical substances, and in this regard amino acids are environmentally friendly and sustainable resources. Typical examples include application of arginine (Arg) as an alternative base to triethanolamine (TEA) and Glu as an alternative acid to hydrochloric acid as neutralizers.

Actual results are greater than expected. For example, soap neutralized with Arg not only has better biodegradability and mildness as expected, but also provides weakly alkaline mild soap formulations

TABLE 15.1
Solubility in Water (g/dL)

Amino Acid	°C												
	0	10	20	25	30	40	50	60	70	75	80	90	100
L-Alanine	12.73	14.17	15.78	16.51	17.68	19.57	21.79	24.26	27.02	28.51	30.08	33.50	37.30
DL-Alanine	12.11	13.77	16.02	16.72	17.83	20.29	23.09	26.27	29.90	31.89	34.01	38.70	44.04
L-Arginine	8.3		14.8				40.0						174.1
L-Asparagine · H ₂ O	0.85	1.43	2.36	3.00	3.78	5.94	9.12	13.68	20.09	24.1	28.77	40.32	55.21
L-Aspartic acid	0.21	0.30	0.42	0.50	0.60	0.85	1.20	1.70	2.41	2.88	3.43	4.88	6.89
DL-Aspartic acid	0.26	0.41	0.63	0.78	0.95	1.39	2.00	2.81	3.84	4.46	5.14	6.73	8.69
L-Cystine	0.0050	0.0069	0.0094	0.011	0.013	0.018	0.024	0.033	0.045	0.052	0.061	0.084	0.114
DL-Cystine	0.0016	0.0021	0.0030	0.0049	0.0049	0.0076	0.0104						
L-Glutamic acid	0.34	0.50	0.72	0.84	1.04	1.51	2.19	3.17	4.59	5.53	6.66	9.66	14.0
DL-Glutamic acid	0.86	1.21	1.72	2.05	2.45	3.48	4.93	7.01	9.95	11.86	14.13	20.05	28.49
L-Glutamic acid · HCl	31.5						52.0						81.0
L-Glutamic acid · Na · H ₂ O	64.1			74.22			91.57						172.0
L-Glutamine			3.25(18°C)	4.25	4.8								
Glycine	14.18	18.04	22.52	24.99	27.59	33.16	39.10	45.26	51.39	54.39	57.29	62.53	67.17
L-Histidine	2.3			4.29		6.4							42.8
L-Histidine · HCl · H ₂ O	29.1			39.0			50.1						93.5
L-Hydroxyproline	28.86	31.56	34.52	36.11	37.76	41.30	45.18	49.41	54.04		59.10	64.64	70.70
L-Isoleucine	3.79	3.88	4.03	4.12	4.22	4.48	4.82	5.24	5.77	6.08	6.40	7.21	8.22
DL-Isoleucine	1.83	1.95	2.12	2.23	2.35	2.65	3.03	3.54	4.20	4.61	5.08	6.24	7.80

(Continued)

TABLE 15.1 (Continued)

Solubility in Water (g/dL)

Amino Acid	°C													
	0	10	20	25	30	40	50	60	70	75	80	90	100	
L-Leucine	2.27	2.30	2.37	2.19	2.49	2.66	2.89	3.19	3.58	3.82	4.10	4.78	5.64	
DL-Leucine	0.80	0.86	0.94	0.99	1.05	1.20	1.41	1.68	2.05	2.28	2.55	3.24	4.21	
L-Lysine · HCl	53.6			40**			111.5		142.8					
L-Methionine	3.0				5.6		7.4							
DL-Methionine	1.82	2.34	3.00	3.36	3.81	4.82	6.07	7.55	9.45	10.52	11.72	14.39	17.60	
L-Phenylalanine	1.98	2.33	2.74	2.97	3.21	3.77	4.43	5.20	6.11	6.62	7.18	8.43	9.90	
DL-Phenylalanine	1.00	1.13	1.31	1.41	1.63	1.82	2.19	2.67	3.31	3.71	4.17	5.32	6.88	
L-Proline	127.2	140.3	154.6	162.3	170.3	187.6	206.7	227.7	250.9		276.4	304.4	335.4	
L-Serine			38.0			60.5		83.0						
DL-Serine	2.20	3.10	4.30	6.02	6.85	7.84	10.34	13.41	17.11	19.21	21.48	26.53	32.24	
L-Threonine		36(14°C)			10.6		14.1(52°C)	19.0(61°C)						
DL-Threonine				20.5							55.0			
L-Tryptophan	0.82	0.93	1.06	1.14	1.22	1.44	1.71	2.06	2.51	2.80	3.12	3.92	4.99	
DL-Tryptophan					0.25									
L-Tyrosine	0.020	0.027	0.038	0.045	0.054	0.075	0.105	0.15	0.21	0.24	0.29	0.40	0.57	
DL-Tyrosine	0.015	0.021	0.029	0.035	0.042	0.064	0.084	0.13	0.17		0.24	0.34	0.48	
L-Valine	8.34			8.85			9.62	10.24(65°C)						
DL-Valine	5.96	6.33	6.81	7.09	7.42	8.17	9.11	10.28	11.74	12.61	13.58	15.89	18.81	

Source: Greenstein JP, Winitz M. *Chemistry of Amino Acids*. p. 564. 1961. Copyright Wiley-VCH Verlag GmbH & Co. KGaA. Reproduced with permission; Dunn MS, Rockland LB. *Advances in Protein Chemistry*. New York: Academic Press, 1947, Vol. 3, pp. 295–382; Akabori S, Mizushima S. *Protein Chemistry*. Kyouritu, Tokyo, 1969, Vol. 1, p. 272; Budavari, S. (ed.) *The Merck Index*. 11th edition. New Jersey: Merck & Co., Inc.; 1989.

TABLE 15.2

Solubility in Aqueous Alcohol Solution (mol/L at 25°C)

Amino Acid	EtOH% (V/V)												
	0	5	10	15	20	40	50	60	70	80	90	95	100
DL-Alanine	1.660	1.460	1.250		0.877	0.402		0.158		0.0359	0.00794		0.00076
L-Arginine	0.350(20°C)												
L-Asparagine	0.186				0.0750	0.0306		0.0105					0.000023
L-Aspartic acid	0.0376				0.0149	0.00575	0.00441	0.00264	0.00149	0.00070	0.00021		0.0000116
L-Cystine	0.0005												
L-Glutamic acid	0.0585												0.0000185
L-Glutamine	0.291												0.0000315
Glycine	2.886	2.156	2.041	1.670	1.343	0.507		0.157		0.0218	0.00556		0.00039
L-Histidine	0.270												
L-Isoleucine	0.314									0.0305(20°C)			0.00534(20°C)
L-Leucine	0.171				0.0977	0.0320		0.0441		0.0204	0.00770		0.00128
DL-Leucine	0.0744	0.0661	0.0575	0.0494	0.0423	0.0264		0.0186		0.00848			
L-Lysine · HCl												0.00547	
DL-Methionine	0.1218												
L-Phenylalanine	0.1792												
D-Phenylalanine	0.1705(16°C)												
L-Proline	1.4071												5.78(19°C)
DL-Serine	0.4780												
DL-Threonine													0.00588
L-Tryptophan	0.0558												
L-Tyrosine	0.0025												
DL-Tyrosine	0.0025												
L-Valine	0.706				0.409	0.231		0.123		0.0373			
DL-Valine	0.571	0.506	0.444	0.382	0.318	0.167		0.086		0.0280	0.00922		0.00128

Source: Adapted from Cohn, EJ et al. *J Am Chem Soc* 1934;56:2270; McMeekin TL et al. *J Am Chem Soc* 1935;57:626; McMeekin, TL et al. *J Am Chem Soc* 1936;58:2173; Budavari, S. ed. *The Merck Index*. 11th edition. New Jersey: Merck & Co., Inc., 1989.

TABLE 15.3

Dissociation Constant (pK) and Isoelectric Point (pI)

Amino Acid	pK ₁	pK ₂	pK ₃	pK ₄	pI
Ala	2.34	9.69			6.00
Arg	1.82	8.99	12.48		10.76
Asn	2.02	8.80			5.41
Asp	1.88	3.65	9.60		2.77
CysH	1.92	8.35	10.46		5.07
Cys	<1.00	2.1	8.02	8.71	4.60
Glu	2.19	4.25	9.67		3.22
Gln	2.17	9.13			5.65
Gly	2.35	9.78			5.97
His	1.78	5.97	8.97		7.59
Hyp	1.82	9.66			5.83
Ile	2.36	9.68			6.02
Leu	2.36(DL)	9.60(DL)			5.98
Lys	2.20	8.90	10.28		9.74
Met	2.13(DL)	9.28(DL)			5.74
Phe	2.16	9.18			5.48
Pro	1.95	10.64			6.30
Ser	2.19	9.21			5.68
Thr	2.15	9.12			6.16
Trp	2.38	9.39			5.89
Tyr	2.20	9.11	10.07		5.66
Val	2.32	9.62			5.96

Source: Adapted from *Kagaku-binran (Chemical Handbook)*, 4th edn. Vol. Basic Data by Chem Soc. Jpn, Tokyo, Maruzen, 1993.

which reduce subsequent skin dryness while enhancing lathering properties.^{3,4} Arg is widely used to neutralize polyacrylate polymers, too, which results in a weakly acidic gel adapted to skin pH. This gel further showed improved treatment effect as hair conditioners to give enhanced smoothness.⁵

Existence and Roles of Amino Acids in the Skin

As a building block of proteins, amino acids are supplied mainly through blood circulation to the living cells. Skin has integrated structures consisting of stratum corneum (SC), epidermis, and dermis consecutively from the outside to the inside of the body. The epidermis and dermis are the organs based on the structured cells, while blood capillaries exist only in the dermis. Thus, amino acids as nutrients are supplied by blood flow to fibroblast cells in the dermis and then to keratinocyte, melanocyte, and other cells in the epidermis through intercellular liquid channels. The SC consists of corneocyte, dead and cornified cells, and intercellular lipid bilayers between the corneocytes. Every corneocyte is interconnected with cholesterol sulfate and desmosome protein.⁶

In the SC there are materials called natural moisturizing factor (NMF) that control hydration, which consequently is an important function of the SC. Amino acids and pyrrolidone carboxylic acid (PCA) are the major constituents of NMF, which are the end metabolite from filaggrin digested by enzymes in the lower part of the SC.⁶⁻⁹ This is confirmed by the fact that the amino acid compositions of NMF and filaggrin are identical.⁷⁻⁹ Note that each major amino acid in the NMF has a unique property corresponding to the elemental functions of the SC. PCA is the most abundant protein metabolite in NMF composed from glutamic acid, and has a high moisturizing effect.^{10,11} In atopic dermatitis, PCA appears to have a greater variation rather than free amino acids.¹²

TABLE 15.4

Optical Rotation

Amino Acid		Specific Rotation (JP ¹ , JPC ² , EP ³ , DAB ⁴ , USP ⁵)				Merck Index ⁶			
		[α] _D	c	Solvent	t(°C)	[α] _D	c	Solvent	t(°C)
Ala	L-	+13.5 ~ +15.5 ⁰¹⁻⁴	10	6NHCl	20	+2.8°	6	H ₂ O	25
		+13.7 ~ +15.1 ⁰⁵	10	6NHCl	25				
Arg	HCl					+8.5°	9.3		26
	L-	+25.5 ~ +28.5 ^{03,4}	8	25%HCl	20	+26.9°	1.65	6NHCl	20
		+26.3 ~ +27.7 ⁰⁵	8	6NHCl	25				
						+12.5°	3.5	H ₂ O	20
					+11.8°	0.87	0.5NNaOH	20	
	HCl	+21.0 ~ +23.5 ^{03,4}	8	25%HCl	20	+12.0°	4		20
		+21.4 ~ +23.6 ⁰⁵	8	6NHCl	20				
Asn	L-, H ₂ O	+33.7 ~ +36.0 ⁰⁴	10	11%HCl	20	+21.9°	12	dilHCl	20
						-5.42°	1.3		20
						+20.°	1mol	1MHCl	20
						-9.3°	1mol	1MNaOH	20
Asp	D-					+5.41°	1.3		20
	L-	+24.0 ~ +26.0 ⁰²⁻⁴	8	25%HCl	20	+25.0°	1.97	6NHCl	20
	D-					-23.0°	2.30	6NHCl	27
CysH	L-	+8.0 ~ +9.5 ⁰⁴	12	7%HCl	20	+6.5°		5NHCl	25
						+13.0°		5NHCl	25
	HCl					+10.0°		5NHCl	25
						+5.0°		5NHCl	25
	HClH ₂ O	+5.5 ~ +7.0 ^{03,4}	8	25%HCl	20				
		+5.7 ~ +6.8 ⁰⁵	8	6NHCl	25				
Cys	L-	-215 ~ -230 ⁰²	2	1NHCl	20	-223.4°		1NHCl	20
Glu	L-	+31.5 ~ +32.5 ⁰²⁻⁴	10	2NHCl	20	+31.4°		6NHCl	22.4
	HCl	+25.2 ~ +25.8 ⁰⁴	10	7%HCl	20	+22.4°	6		22
	D-					-30.5°	1.00	6NHCl	20
Gln	L-	+6.8 ~ +7.3 ⁰²	4	H ₂ O	20	+6.1°	3.6		23
		+31.5 ~ +33.0 ⁰⁴	10	7%HCl	20				
His	L-	+11.8 ~ +12.8 ⁰²⁻⁴	11	6NHCl	20	-39.74°	1.13		20
		+12.6 ~ +14.0 ⁰⁵	11	6NHCl	25				
	HCl					+8.0°	2	3MHCl	26
	2HCl					+47.6°	2		20
	HClH ₂ O	+8.5 ~ +10.0 ⁰²	11	6NHCl	20				
		+9.2 ~ +10.6 ^{03,4}	11	25%HCl	20				
Hyp	L-					-76.5°	2.5	H ₂ O	-
	cis					-58.1°	5.2	H ₂ O	18
Ile	L-	+39.5 ~ +41.5 ⁰¹	4	6NHCl	20	+11.29°	3		20
		+39.0 ~ +42.0 ^{03,4}	4	25%HCl	20				
		+38.9 ~ +41.8 ⁰⁵	4	6NHCl	25				
					+40.61°	4.6	6.1NHCl	20	
					+11.09°	3.3	0.33NNaOH	20	
Leu	L-	+14.5 ~ +16.0 ⁰¹	4	6NHCl	20	-10.8°	2.2		25
		+14.5 ~ +16.5 ^{03,4}	4	25%HCl	20				
		+14.9 ~ +17.3 ⁰⁵	4	6NHCl	25				

(Continued)

TABLE 15.4 (Continued)

Optical Rotation

Amino Acid	Specific Rotation (JP ¹ , JPC ² , EP ³ , DAB ⁴ , USP ⁵)				Merck Index ⁶					
	[α] _D	c	Solvent	t(°C)	[α] _D	c	Solvent	t(°C)		
Lys	L-				+15.1°		6NHCl	26		
					+7.6°		3NNaOH	20		
					+14.6°	6.5			20	
					+25.9°	2	6.0NHCl		23	
		HCl	+19.0 ~ +21.6°	8	6NHCl	20	+14.6°	2	0.6NHCl	25
			+21.0 ~ 22.5 ^{o3,4}	8	25%HCl			20		
			+20.4 ~ +21.4 ^{o5}	8	6NHCl			25		
Met	L-	2HCl			+15.3°	2		20		
			+21.0 ~ +25.0 ^{o1}	2	6NHCl	20	-8.2°		25	
			+22.5 ~ +24.0 ^{o4}	2	22%HCl	20				
Phe	L-		+21.9 ~ +24.1 ^{o5}	2	6NHCl	25				
			-33.0 ~ -35.5 ^{o1,3,4}	2	H ₂ O	20	-35.1°	1.94		20
			-32.7 ~ -34.7 ^{o5}	2	H ₂ O	25				
Pro	L-									
			-84.0 ~ -86.0 ^{o2-4}	4	H ₂ O	20	+35.0°	2.04		20
			-84.3 ~ -86.3 ^{o5}	4	H ₂ O	25	+7.1°	3.8	18%HCl	20
Ser	L-									
			-85.0°						23.4	
			+13.5 ~ +16.0 ^{o2}	10	2NHCl	20	-52.6°	0.58	0.5NHCl	20
	+14.0 ~ +16.0 ^{o3,4}	10	7%HCl	20	-93.0°	2.4	0.6NKOH	20		
	+14.0 ~ +15.6 ^{o5}	10	2NHCl	25	-6.83°	15g in	15g aq.soln	20		
Thr	L-									
			-26.0 ~ -29.0 ^{o1}	6	H ₂ O	20	+14.45°	0.5g in	5.6NHCl	25
			-27.6 ~ -29.0 ^{o4}	6	H ₂ O	20	-28.3°	1.1		26
Trp	L-		-26.7 ~ -29.1 ^{o5}	6	H ₂ O	25				
			-30.0 ~ -33.0 ^{o1,4}	1	H ₂ O	20	-31.5°	1		23
			-29.4 ~ -32.8 ^{o5}	1	H ₂ O	25				
Tyr	L-									
			+2.4°					0.5NHCl	20	
			+0.15°	2.43				0.5NNaOH	20	
			-10.5 ~ -12.5 ^{o2}	5	1NHCl	20	-10.6°	4	1NHCl	22
			-11.0 ~ -12.3 ^{o4}	5	7%HCl	20				
Val	L-		-9.8 ~ -11.2 ^{o5}	5	1NHCl	25				
			-13.2°	4				3NNaOH	18	
	+10.3°	4				1NHCl	25			
Val	L-		+26.5 ~ +29.0 ^{o1,3,4}	8	6NHCl	20	+13.9°	0.9		26
			+26.5 ~ +28.8 ^{o5}	8	6NHCl	25				
							+22.9°	0.8	20%HCl	23

¹ JP: Japanese Pharmacopeia 12th Rev., Amend. 1&2² JPC: Japanese Pharmacopeia (1993)³ EP: European Pharmacopeia 2nd Ed.⁴ DAB: German Pharmacopeia 10th Ed.⁵ USP: United States Pharmacopeia 23rd Ed.⁶ Merck Index 11th Ed. (1989)

TABLE 15.5

Reactivity

Amino Acid	Reactivity	Flavor Characteristics
		Heating at 180°C with Glucose
Ala	–	Caramel like
Arg	Hydrolyzed by heat or alkali, to convert to citrulline or Orn	Burned sugar
Asn	Hydrolyzed by acid or alkali, to convert to Asp	
Asp	–	Caramel like
CysH	Chemically unstable, trace amount of heavy metal (Fe, Cu, etc.) accelerate oxidation, air oxidation occurs under neutral or alkalic aq. Conditions to convert to Cys.	
Cys	Decompose by heat or alkali in aq. solution	Sulfur
Glu	Dehydrate to PCA over 160°C	Burned sugar
Gln	Hydrolyze by acid, alkali, or hot water to convert to Glu then cyclized to PCA	Butter
Gly	Heating with glucose produce formaldehyde	Caramel like
His	–	Corn bread
Ile	Heating with glucose produce 2-methyl-butanal	Burned cheese
Leu	Heating with glucose produce iso-valeric acid	Burned cheese
Lys	Become di-hydrate over 60%RH, heat with acid or alkali cause racemization	Bread
Met	Heat with strong acid cause demethylation, identical biological activity for L and D isomers	Potato
Phe	Decompose under alkalic condition to produce benzaldehyde, heating with glucose produce α -toluic acid	Vaiolat, lilac, saffron
Pro	Heating with glucose produce acetoaldehyde	Bread
Ser	Racemization at pH9, decompose by hot alkalic condition, heating with glucose produce glycolic acid	Caramel like
Thr	Decompose by heat or alkali in aq. solution, heating with glucose produce lactic acid	Burned fume
Trp	Decompose by heating with strong alkali, long exposure to light cause colorization	
Tyr	–	Caramel like
Val	Heating with glucose produce iso-lactic acid	Chocolate

Arg is second to PCA when combined with its metabolite ornithine (Orn) and citrulline (Cit). Arg is a water-soluble basic amino acid whose roles in the skin have been extensively investigated in the past decade.^{13,14} Skin suppleness depends on the hydration and elasticity of keratin fibers in the corneocyte. Arg stimulates aggregation of keratin filament to make organized and elastic structures in the SC.¹⁴

Proline (Pro) has unique characteristics: highly soluble in water and at the same time soluble in alcohol.² Pro has the highest water holding capacity among the amino acids under dry conditions. Synergistic hygroscopicity was found for Pro when combined with PCA, which supports the rationale of their abundant co-existence in NMF.¹⁵ Urocanic acid (UA) is an end metabolite of histidine (His), whose role has been unveiled as an immune regulator rather than an ultraviolet (UV) absorber, which it was long considered to be.^{16–18} UV exposure converts trans UA to cis isomer, which has immune suppressing effect. All these functions are interconnected and controlled under homeostatic regulation.¹⁹

Harmonized Integrity of Skin Function with Amino Acids

As explained above, NMF is a metabolite of filaggrin, whose production requires optimally moisturized enzymatic conditions in the lower part of the SC.⁶ Similarly, enzymatic decomposition of desmosomes for

TABLE 15.6

Reactivity (Sensitivity to Decomposition under Each Condition)

	Amino Acid	Ala	Arg	Asn	Asp	CysH	Cys	Glu	Gln	Gly	His	Ile	Leu	Lys	Met	Phe	Pro	Ser	Thr	Trp	Tyr	Val
Sensitive to																						
Heat	Boil			X					X													
	Broil (dry heating)		X	X	X	X	X	X	X		X			X	X			X	X	X		
pH	Acidic			X					X												X	
	Alkalic		X	X		X	X		X					X				X	X			
Oxidation	In air								X						X							
	with oxidant					X	X								X							X
Photo sensitive dye											X											X
Peroxidized lipid			X			X	X				X			X	X							X
Maillard reaction with sugar			X											X	X							X

Note: X: amino acid sensitive to decomposition under each condition.

TABLE 15.7

Acute Oral Toxicity (LD50) (g/kg—Rat Body Weight)

Amino Acid	LD ₅₀
L-Ala	>16
L-Arg	≈16
L-Asn	>16
L-Asp	>16
L-CySH · HCl · H ₂ O	3.1 (2.7 ~ 3.6)*
L-Cys	11.2 (9.0 – 14.0)*
L-Gln	>16
Gly	≈16
L-His	>16
L-Hyp	>16
L-Ile	>16
L-Leu	>16
L-Lys · HCl	10.6 (3.5 ~ 11.9)*
L-Met	>16
L-Phe	≈16
L-Pro	>16
L-Ser	14.0 (12.8 ~ 15.3)*
L-Thr	>16
L-Trp	>16
L-Tyr	>16
L-Val	>16
	3.75 ¹
L-Glu · Na	>19.9 ²

*95% confidence limit.

¹ Merck Index, 11th ed. (1989)² Finchemical & Intermediates, Vol. 1, CMC pub., 1990

the exfoliation of corneocytes depends on the moisture content in the upper part of the SC.^{6,20} Bouwstra et al. showed that water distribution in the SC layers is not a simple gradient that is high at the stratum granulosum (SG) border and declining toward the outside of SC; instead, by careful examination through TEM and NIR they found the highest water content in the middle SC layers.^{21–23} By advanced NIR measurement and analysis Lucassen found similar water distribution along with molecular distribution attributed to the amino acids.²⁴ Inoue et al. also observed incremental amino acid existence for the tape stripped SC up to mid SC layers.²⁵ As Rawlings precisely explained, structures of SC and distribution of key constituents for SC functions are not uniform from the bottom to the top of SC layers.⁶ At the bottom of the SC, which borders the SG, which are living cells with full hydration, enzymes are activated by suitable water content to produce NMF and cellamide. At the middle of the layers, SC is fully functioning in its structure and constituents with the highest barrier capacity and flexible physical strength.⁶ Elias explained pH distribution in the SC by similar integration of functions.¹⁹

These facts indicate that the existence and amount of NMF in the SC are the cause and the result of a skin condition. Changes of skin amino acid contents and compositions in the SC of aged dry skin (senile xerosis) or disordered skin in atopic dermatitis or chemically induced dry skin are the actual evidence of this assumption.^{26,27} Furthermore, we found decreased hydration and barrier function for subjects suffering seasonal respiratory allergic reactions but with no obvious signs or changes on the skin conditions.

Fairly good correlations between skin hydration and level of amino acid content in the SC for these patients are found.²⁸ In each case, lack of sufficient NMF cause loss of skin hydration and even suggests that analysis of skin amino acids can be a useful diagnostic prediction, as shown in the case of respiratory allergic patients.²⁸ However, it must be noted that the PCA concentrations may be an important factor, as one study noted no change in amino acid content in the NMF but in the PCA content.¹²

Effective Amino Acid Delivery into Skin

There are several beneficial effects with the topical application of amino acids. Application of topical amino acids have been shown to improve wound healing rates.²⁹ However, topical amino acids in intact skin has been shown to have biological effects as well. Occlusive application of a mix of amino acids on the back of the rats fed protein deficient food showed faster weight gain and even hair growth than rats treated with placebo.³⁰ Topical application of 1-carbamimidoyl-L-proline (CLP) has been shown to improve surface roughness and elasticity, suggesting an improvement in local hydration of the SC.³¹ These transepidermal effects are found under abnormal conditions, which may enhance amino acids percutaneous penetration. Cutaneous absorption of amino acids is low because of their hydrophilic nature.³² Intercellular lipid bilayers in the SC work as a barrier for water soluble molecules and water is held mostly in the corneocyte, as the water holding capacity of bilayers are limited approximately to less than 15% of total water contents in normal conditions.^{21–23,33} Therefore, it is assumed that water in the corneocyte works primarily as a reservoir of hydrophilic molecules. Interestingly, the amount of Pro in the SC increased when combined with other NMF constituents such as Na PCA, Na lactate, or glycerin, which lead to enhanced Pro penetration through the skin because of the increased concentration gap between the SC and the epidermis by Fick's equation.³⁴ Noteworthy is that these combinations are exactly the same ones that show synergistic hygroscopicity, as mentioned before.¹⁵

Enhancement of amino acid penetration can be achieved by modifying amino acids to be more hydrophobic to enhance percutaneous drug delivery. For example, esters of Phe showed higher transepidermal penetration compared with Phe itself. Only Phe was detected in the receiver solution, which indicates that esterase in the epidermis hydrolyzed the Phe-ester to Phe.³⁵

As mentioned before, the role of amino acids in the SC depend on their physicochemical properties such as hygroscopicity, water holding capacity, and pH buffering. On the other hand, physiological functions of amino acids are more prominent in the metabolically active cells in the skin. For example, Arg is a precursor of NO, which is an important regulator of blood microcirculation in the dermis. We found it stimulated NO production *in vitro* and temporal redness *in vivo* when PCA is topically administered.³⁶ It was found in this phenomena that PCA stimulated transportation of Arg through the cationic amino acid transporter CAT II channel, but no stimulation of constitutive NO synthase (cNOS) nor activation of induced NO synthase (iNOS). Thus, more Arg is available for cNOS in the endothelial cell which results in increased NO production. Stimulation of Arg and Lys intake to the other skin related cells, keratinocyte and fibroblast, is also observed.³⁷ Tyr, Cystine (Cys), and Pro are key molecules for the generation and differentiation of melanin.^{38–40} A topical gel that contained acetyl cysteine and phenylalanine was shown to help repigmentation in vitiligo, although this study did not utilize a placebo gel.⁴¹ As such, amino acids play important physiological roles for the generation and integration of skin function. Therefore, the enhanced utilization of amino acids by on-demand delivery is an important task for advancements in cosmeceutical therapies.

Amino Acid Derivatives for Extended Applications

Besides application of amino acids to the skin, there are different aspects of utilization of amino acid derivatives in skin care products. Amino acids are reactive molecules easily converted to varieties of functional materials.¹ A key factor in the practical utilization of amino acid derivatives is the development of novel molecules that are superior in function and competitive in cost. Strategic molecular design

should be applied to enhance physiological functions of amino acids while restoring their friendliness for human use and their durability after use. Understanding of both basic features of amino acids and the processing of molecular modification are the basics of such development. As details of functional amino acid derivatives have been introduced in some articles, the historical trends for such development are reviewed here.

As a general statement it can be said that history evidently shows that whenever characteristics of an amino acid derivative are matched to the market demand there was the creation of new applications. In the area of skin care, Na PCA was developed when the concept of NMF was created in the 1970s.⁷⁻⁹ At that time, there was the establishment of mass production for monosodium glutamate as a food additive, and industrial utilization of it was under exploration, which stimulated its modification to PCA. The combination of other molecules with NMF for cosmetic formulations was not popular until the synergistic effect of PCA with Pro and lactate was found, along with the establishment of production of Pro at a reasonable scale. Formulated NMF moisturizers were developed as a result.¹⁵ About the same time, gel emulsification methods using amino acids were established by Kumano et al.,⁴² which opened the door for the utilization of amino acids in their physicochemical aspects. In the 1980s, the application of urocanic acid and its ester as natural UV absorbers and of amino acid fatty esters with EO moieties as super fattening agents or co-emulsifiers followed.⁴³

In the 1990s, cholesterol esters of N-acylamino acid were developed as novel emollients with similar functions as celamides, which are the key components of lipid bilayers in the SC as a barrier.⁴⁴ Several advancements for the better understanding of physiology in the SC and the role of amino acids occurred in the 1990s. As an example, Ala or Ser were found to stimulate the activation of enzymes for desquamation.⁴⁵ Further functional modification of these molecules can be expected for practical effectiveness.

Solar UV light contributes to skin photodamage, such as skin cancer, photoaging, photosensitization, and other light related skin pathologies.^{46,47} Reactive oxygen species (ROS) are deeply involved in the UV-induced photodamage. Iron release is involved in the oxidative stress caused by UVA.⁴⁸ Therefore, it is important to design antioxidants with an iron sequestering capacity.^{49,50} Conjugates of amino acids with naphthaldehyde or salicylaldehyde are designed by mimicking the active site of the iron sequestering proteins transferrin and ferritin.⁵¹ These molecules suppress iron-induced hydroxyl radical generation and reduce the UV-induced oxidative stress by sequestering the catalytically active iron. To create an ideal cosmetic antioxidant that is not only functional but also provides cosmetic efficacy, conjugates of vitamin B6 with an amino acid, N-(4-pyridoxylmethylene)-L-serine (PYSer), were developed. These molecules have structural similarity to the amino acid iron chelator mentioned before and show anti-oxidative effects against UV radiation. PYSer suppresses iron-induced hydroxyl radical generation and UV-induced wrinkle formation. Since the compound forms stable complexes with Fe³⁺ and inhibits iron-induced hydroxyl radical generation, it is expected to suppress free radical reactions by sequestering the catalytic iron in the body. In summary, PYSer shows a protective effect on photoaging in hairless mice. The mechanism of the photo protection seems to be by the suppression of hydroxyl radical generation, as shown in an *in vitro* assay.⁵¹ UV exposure generates various cytokines, such as IL-1 α , NF- κ B, which lead many physiological and cosmetic skin deteriorations, such as inflammation and hyperpigmentation. For example, cystine and cysteine derivatives show suppression of UV induced inflammation.⁵²

Besides development of the bio-functional molecules mentioned above, many amino acid-based surfactants have been developed in expectation of their incorporation for human use and acceptability for the environment.^{53,54} N-acylglutamate was launched first into the Japanese market as a new generation of amino acid-based mild and functional anionic surfactant. With its weakly acidic nature similar to skin pH and very gentle safety profile for the skin, N-acylglutamate led to the creation of a mild cleanser market in Japan,^{55,56} coincidentally promoted by consumers seeking safe products because of issues of hyperpigmentation caused by some cosmetic products. Lys and Arg were the next amino acids commercially modified as surfactants because of their stable supply and reasonable cost. N-Lauroyl lysine has superior surface modifying effects for various inorganic powders and a smooth touch to the skin by itself, and is thus used for cosmetic products, especially for powder formulations.^{57,58} N-cocoylarginine ethylester PCA (CAE) salt is a cationic surfactant with hair conditioning, antimicrobial and many other properties as cationic surfactant, but mild in terms of irritation to the eye and skin and highly biodegradable, which are problems with common cationic surfactants.⁵⁹ Hence, CAE has been used in many skin preparations

as antimicrobial, and for hair care preparations as a conditioning and antistatic agent. Further, addition is made of arginine as an amphoteric surfactant but of strongly cationic character. N-Alkylether-hydroxypropyl arginine was developed to meet market needs for an environmentally-friendly agent as an alternative to quaterammonium cationics, with the features of mild irritation, reasonable biodegradability, and sufficient hair conditioning effect.⁶⁰

In the past decade, other amino acid-based anionic surfactants have become common, even in mass-market products. N-Acylmethyltaurate has helped further expansion of the amino acid surfactant share in the anionic surfactant market, especially for shampoo preparations.^{61,62} N-Acyl glycinate and alanate boost this trend further, with their excellent lathering properties and refreshed skin feel. These characteristics are highly rated by consumers for cleansers, which glutamate and other previously-mentioned N-acylamino acids could not fulfill.⁶³

These functional amino acid derivatives have many advantages compared to the traditional synthetic molecules. Principally they are safe and friendly to humans and the environment. The functionalities of these materials are even better than the traditional synthetic materials because of the structural similarity or affinity of such amino acid derivatives to the human body.

Conclusions

The roles and functions of amino acids in the skin have been reviewed. Each amino acid has a reason for existence, with its role and functions in the skin, but, more importantly, these molecules are interrelated to maintain the homeostasis of the skin. Further advancement of skin research will lead us to develop better uses for amino acids and their derivatives.

REFERENCES

1. Greenstein JP, Winitz M. *Chemistry of Amino Acids*. New York: John Wiley & Sons, Inc; 1961.
2. *Amino Acid Data Book*, 1996 edition. Japan Essential Amino Acids Association.
3. Abe H et al. *J Soc Cosmetics Chem Jpn* 1996;30(4):396.
4. Okumura H. *Fragrance J* 1996;7:42; JP52-15687, 01-238521, 01-238522.
5. FRP2040954_A. *Ajinomoto Technical Data* 3000-0200, June 1998.
6. Rawlings AV et al. *J Invest Dermatol* 1994;103:731.
7. Jacobi OT. *Pro Sci Sect Good Assoc* 1959;31:22
8. Laden K. *Amer Perf and Cosmetics* 1967;82:77
9. Tatsumi S. *Amer Cosmetics Perfum* 1972;87:61.
10. Pascher G et al. *Klin & Exptl Dermatol* 1956;203:334
11. Pascher G et al. *Klin & Exptl Dermatol* 1957;204:140.
12. Sugawara T et al. *J Dermatol Sci* 2012;66(2):154–9.
13. Sauer mann G, Richert S, Steinhart H, Hoppe U. *Determination of Oxidized Proteins in Human Stratum Corneum*. Proceedings of the 18th IFSCC Congress, Venezia: Italy; pp. 138–150, 1994.
14. Kawada Y et al. *Soc Cosmetics Chem Jpn, Ann Sci Seminar* June 1998, Osaka, Japan.
15. Sakamoto K. *Cosmet Toilel* 1984;99(3):109.
16. Igata S et al. *J Soc Cosmetics Chem Jpn* 1993;27(3):450.
17. Noonan FP, De Fabo EC. *Immunol Today* 1992;13:259.
18. Dahl MV et al. *Photodermatol Photoimmunol Photomed* 2010;26(6):303–10.
19. Scott I et al. *BBA* 1982;719:110.
20. Kitamura K et al. *J Soc Cosmetics Chem Jpn* 1995;29:133.
21. Bouwstra JA et al. *IFSCC*, Edinburg, 2002
22. Bouwstra JA et al. *J Invest Dermatol* 1991;97:1005
23. Bouwstra JA et al. *Controlled Release* 1991;15:209.
24. Lucassen GW. *IFSCC/ISBS Workshop*, Edinburg, September 27, 2002.
25. Inoue M et al. *Conference of Soc Cosmetics Chem Jpn* Tokyo, October 2002.
26. Hara M et al. *J Geriatr Dermatol* 1993;1:111.
27. Watanabe M et al. *Arch Dermatol* 1991;137:1689.

28. Tanaka M et al. *Br J Dermatol* 1998;139:618.
29. Ponrasu T. *Amino Acids* 2013;45(1):179–89.
30. Katayama Y et al. *XIII Intl Congr Nutrition* Brighton, UK; 1986.
31. Kawashima M. *Eur J Dermatol* 2013;23(2):195–201.
32. Sznitowska M et al. *Int J Pharm* 1993;99:43.
33. Imokawa G et al. *Invest Dermatol* 1991;96:845.
34. Kawasaki Y et al. *J Soc Cosmetics Chem Jpn* 1996;30:55.
35. Kouzuki Y et al. *Drug Der Syst* 1995;10:37.
36. Ogasahara K et al. *J Soc Cosmetics Chem Jpn* 2003;6(3):229–232.
37. Ogasahara K et al. *IFSCC Conference*, Seoul, September 2003.
38. Ito S et al. *J Invest Dermatol* 1993;100:166
39. Kobayashi T et al. *Pig Cell Res*1994;7:227
40. Kobayashi T et al. *EMBO J* 1994;13:5818.
41. Buggiani G. *Dermatol Ther* 2012;25(5):472–6.
42. Kumano Y et al. *J Soc Cosmetics Chem Jpn* 1977;28:285.
43. Sagawa K et al. *Fragrance J* 1988;89:109.
44. Ishii H et al. *J Soc Cosmetics Chem* 1996;47:351.
45. Koyama J et al. *19th IFSCC Congress, Proceedings*, Sidney, 1996.
46. Kitazawa M, Iwasaki K, Sakamoto K. *J Cosmet Dermatology* 2006;5:210–17.
47. Black HS. *Photochem Photobiol* 1987;46:213.
48. Pourzand C et al. *Proc Natl Acad Sci USA* 1999;96:6751.
49. Bissett DL et al. *Photochem Photobiol* 1991;54:215.
50. Kitazawa M, Iwasaki K. *Biochim Biophys Acta* 1999;1473(2–3):400–8.
51. Kitazawa M, Iwasaki K. *Biochem Biophys Res Commun* 1996;220:36.
52. Kitazawa M et al. *FEBS Letters* 2002;526:106.
53. Sakamoto K et al. Protein based surfactants. In: Xia J and Nnann IA, eds, *Surfactant Science Series*. New York: Marcel Dekker, Inc.; 2001, Vol. 101, Chapter 4, p. 75.
54. Sakamoto K. Yukagaku. *J Oleo Sci* 1995;44:256–65.
55. Sakamoto K. Protein based surfactants. In: Xia and Nnann, eds, *Surfactant Science Series*. New York: Marcel Dekker, Inc.; 2001, Vol. 101, Chapter 10, p. 261
56. Saito T. *Cosmetics and Toiletries* 1983;98:111.
57. Yokota H et al. *J Am Oil Chem Soc* 1985;62(12):1716.
58. Sagawa K et al. *Fragrance J* 1986;14:71.
59. Yoshida R et al. Yukagaku. *J Oleo Sci* 1976;25(7):404.
60. Tabohashi T et al. *Fragrance J* 1998;26:58.
61. Tabohashi T et al. *Colloids and Surfaces B: Biointerfaces* 2001;20:79–86
62. Kouchi J et al. *J Oleo Science* 2001;50:847.
63. Miyazawa K et al. *J Oleo Sci* 1989;38:297.
64. McMeekin TL et al. *J Am Chem Soc* 1934;56:2270.
65. McMeekin, TL et al. *J Am Chem Soc* 1935;57:626.
66. Cohn EJ et al. *J Am Chem Soc* 1936;58:2173.
67. Dunn MS, Rockland LB. In: Anson ML, Edsall JT, eds, *Advances in Protein Chemistry*. New York: Academic Press, 1947, Vol. 3, pp. 295–382.
68. Akabori S, Mizushima S. *Protein Chemistry*. Kyouritu, Tokyo, 1969, Vol. 1, p. 272.
69. Budavari, S. ed. *The Merck Index*. 11th edition. New Jersey: Merck & Co., Inc. 1989.

16

Antioxidants

Frank Dreher, Jens Thiele, and Jacquelyn Levin

Introduction

The skin forms an efficient barrier against xenobiotics entering our body and protects from the harmful environment, encompassing exposure to solar ultraviolet radiation (UVR) and air pollutants. Such exposure results in the formation of reactive oxygen species (ROS) and other free radicals including reactive nitrogen species (RNS), which may subsequently react with skin biomolecules. The skin is equipped with a variety of antioxidants forming an antioxidant network intervening at different levels of oxidative processes by scavenging and removing free radicals or oxidatively damaged biomolecules in order to counteract ROS and RNS induced oxidative stress.^{1,2} However, the antioxidant defense in cutaneous tissues can be overwhelmed by exposure to exogenous sources of oxidative stress, ultimately leading to skin damage. Well-documented solar UVR-induced skin damage includes sunburn (erythema, edema), and exfoliation, followed by tanning and epidermal thickening. Premature skin aging (photoaging) and photocarcinogenesis are the consequences of chronic UVR exposure.

Terrestrial solar UVR consists of UVB (290–320 nm) and UVA (UVA II: 320–340 nm, UVA I: 340–400 nm). Radiation less than 290 nm (UVC) does not reach the earth's surface, since these wavelengths are absorbed by stratospheric ozone. Besides UVR and air pollutants such as tropospheric ozone, the presence of chemically unstable and ROS/RNS forming drugs, as well as some exogenous photoreactive chemicals in skin, can be other sources of cutaneous oxidative stress. Further, mitochondrial oxidative stress has been described as an additional possible cause of skin photoaging.³

This chapter summarizes the currently available knowledge on mechanisms and sites of oxidative stress in skin, the role of oxidative stress in the formation of skin damage, and its prevention by strategies strengthening the skin's antioxidative defense capacity through topical supplementation.

Reactive Oxygen Species

Several steps lead to the formation of ROS/RNS as a consequence of UVR exposure.^{1,2} The cascade of ROS/RNS formation is initiated by UVR-absorption; predominantly in the UVA region, of endogenous or exogenous chromophores in the skin. Of the many skin constituents capable of absorbing UVA, *trans*-urocanic acid, flavins, porphyrins, protein bound tryptophan, and advanced glycation end products are believed to be relevant photosensitizers initiating the ROS/RNS formation cascade. Following UVR absorption, the activated chromophore may react in two ways. In type I photoreactions, the excited chromophore directly reacts with a substrate molecule via electron or hydrogen atom transfer and gives rise to free radical formation. In the presence of molecular oxygen (minor type II reaction), this reaction may lead to the formation of superoxide anion radical $\cdot\text{O}_2^-$. Subsequently, $\cdot\text{O}_2^-$ gives hydrogen peroxide (H_2O_2) by a dismutation reaction either spontaneously or catalyzed by cutaneous superoxide dismutase. Further, in the presence of metal ions such as Fe(II) or Cu(II), H_2O_2 can be converted to the highly reactive hydroxyl radical $\cdot\text{OH}$. Otherwise (major type II reaction), electronically excited and reactive singlet oxygen $^1\text{O}_2$ is formed by photoenergy transfer from UVR-excited chromophores in the presence of triplet oxygen $^3\text{O}_2$ (molecular oxygen in its ground state). Following their formation, ROS species including $^1\text{O}_2$, $\cdot\text{O}_2^-$, $\cdot\text{OH}$, H_2O_2 react with an array of skin biomolecules including lipids, DNA, proteins,

and carbohydrates. For instance, unsaturated skin lipids (LH) may react with ROS forming lipid peroxyl (LOO^{\bullet}) and alkoxyl radicals (LO^{\bullet}), which can initiate a chain-propagating, autocatalytic reaction. Further, ROS cause modifications of amino acids of proteins resulting in functional changes of structural or enzymatic proteins. Reaction of singlet oxygen with DNA results in the formation of 8-hydroxydeoxyguanosine along with other ROS mediated DNA damage.

UVB absorption of DNA leads to major base modifications such as pyrimidine dimer or (6–4) photoadduct formation. Hence, since DNA absorbs strongly in the UVB region and is only a weak chromophore in the UVA region, UVB is largely considered as a direct, ROS-independent inducer of DNA damage, in contrast to UVA.⁴ Those modifications together with DNA damage induced by ROS are responsible for solar genotoxicity.

Oxidative damage to mitochondrial DNA (mtDNA), in addition to its role in several degenerative diseases, has been recently described to play a major role in photoaging.³ Intra-individual comparison studies have shown that a common deletion of mtDNA is increased about 10-fold in photoaged skin as compared to sun protected skin in the same individuals.⁵ Although normal ATP production in the mitochondria results in some level of oxidative stress, it is thought that UVA exposure increases the extent of oxidative stress in the mitochondria and induces mutations of mtDNA, leading to a defective respiratory chain. The defective respiratory chain results in reduced energy production by the mitochondria and increased production of ROS.^{6–9} This increase in ROS, in a positive feedback manner, leads to more mtDNA mutations which further perpetuate the production of ROS. As a consequence, mtDNA mutations will increase even in the absence of UV exposure.¹⁰ This hypothesis has been termed “the defective powerhouse model of premature skin aging,”³ and is supported by the following observations: (1) repetitive sublethal doses of UVA irradiation at doses equivalent to a regular summer holiday induces mutations of mtDNA in keratinocytes and fibroblasts in a singlet oxygen-dependent fashion,^{11–13} (2) UVA induced mtDNA deletion also leads to an increase of the collagen degrading enzyme MMP-1 without increase in TIMP-1 indicating the role of mtDNA mutations in the process of photoaging that is mediated by MMP-1,¹⁰ and (3) *in vivo* studies have shown that repetitive exposure (three times daily) of previously non-irradiated human buttock skin with physiological doses of UVA radiation for a total of two weeks leads to an approximately 40% increase of the common deletion in the dermal, but not the epidermal compartment of irradiated skin.¹⁴ Taken together, these studies convincingly indicate that UVA can induce mtDNA mutations in skin fibroblasts, which subsequently result in structural and functional alterations in the extracellular matrix characteristic of photoaged skin.

Constitutive Skin Antioxidant Network

Skin is equipped with a complex, cooperative network of enzymatic and non-enzymatic antioxidants to limit oxidative stress.^{1,2} Antioxidant enzymes such as catalase, superoxide dismutases (SOD), glutathione reductase and peroxidase, glutathione-S-transferase, and thioredoxin reductase and peroxidase interact with low molecular weight lipophilic antioxidants including tocopherols and tocotrienols (vitamin E homologs), ubiquinols (coenzyme Q) as well as hydrophilic antioxidants such as vitamin C (L-ascorbic acid) and glutathione (GSH) (see Figure 16.1). Carotenoids, retinoids, and uric acid are also detected in skin but their antioxidant role within the cutaneous antioxidant network seems currently less clear.

α -Tocopherol, the predominant vitamin E homolog in skin, efficiently scavenges lipid peroxyl and alkoxyl radicals by intercepting lipid chain propagation. This results in the formation of the meta-stable tocopheroxyl radical, which either reacts with another lipid radical, leading to α -tocopherol consumption, or abstracts a hydrogen atom from polyunsaturated lipids to give α -tocopherol and a lipid radical. In the latter case, occurring preferentially at low lipid radical concentration, the lipid radical can later react with oxygen to form a lipid peroxyl radical. Consequently, this reaction induces the α -tocopherol mediated lipid peroxidation chain reaction. Formation of one molecule of α -tocopherol radical results in the formation of many other lipid hydroperoxides. However, in the presence of ascorbic acid, the tocopheroxyl radical is rapidly reduced and α -tocopherol is regenerated. Thereby, the α -tocopherol mediated lipid peroxidation chain reaction is terminated. In addition, ascorbic acid is also an efficient scavenger of superoxide anion radicals, hydroxyl radicals, and singlet oxygen, as well as water soluble

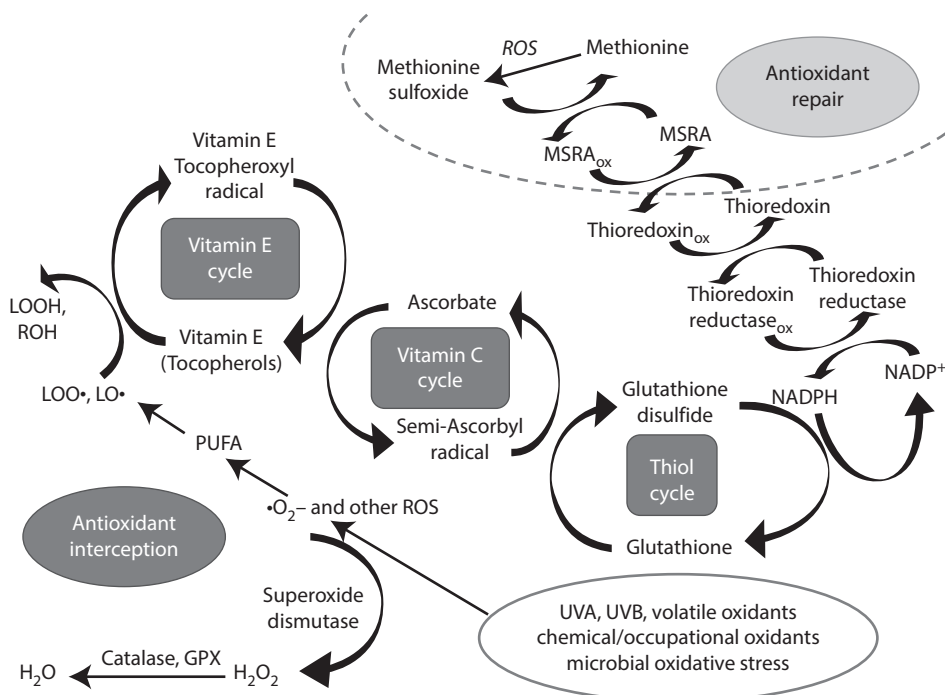

FIGURE 16.1 Postulated activation of interactive network of antioxidants and antioxidant enzymes by oxidative stress in skin; note that some of the depicted antioxidant recycling mechanisms have been found *in vitro* and in other than cutaneous systems.

peroxyl radicals. The resulting ascorbic acid radical is either recycled to ascorbic acid by co-antioxidants including GSH or is further oxidized to dehydroascorbic acid and irreversibly decomposed, respectively. GSH can also react with singlet oxygen, superoxide anion radicals, and hydroxyl radicals resulting in the formation of the thiyl radical GS^{\bullet} and subsequently glutathione disulfide GSSG. GSSG can be recycled to GSH by the NAD(P)H-dependent enzyme glutathione reductase.

GSH further acts as a cofactor for numerous reducing enzymes, among them glutathione peroxidases. Glutathione peroxidase utilizes lipid peroxides as substrate and converts them to hydroxy fatty acids. GSH is likewise used by glutathione-S-transferases, which catalyze the conjugation of GSH to a variety of electrophils including oxidized lipids, DNA, and other products generated by ROS-induced reactions with those skin biomolecules. Glutathione-S-transferases play an important role in detoxifying from oxidatively damaged skin biomolecules.

Moreover, skin contains catalase, which eliminates H_2O_2 similarly to glutathione peroxidase; however, the activity of catalase is much higher than glutathione peroxidase in human epidermis.¹⁵ Besides GSH-oxidase, skin also contains the selenium-dependent enzyme thioredoxin reductase.¹⁶ Thioredoxin reductase, together with its electron acceptors thioredoxin and thioredoxin peroxidase, participates in cutaneous H_2O_2 turnover.

Along with skin's "interceptive" antioxidant network that scavenges ROS and RNS, skin also possesses mechanisms of "antioxidant repair" which are able to reverse oxidatively damaged proteins.¹⁷ However, the accumulation of oxidized amino acids in proteins mostly is irreversible, with few exceptions. For example, oxidized methionine and cysteine are two amino acids that can be reversed to their reduced forms. Methionine sulfoxide accumulation in protein oxidative damage occurs as two different forms, methionine-R-sulfoxide and methionine-S-sulfoxide. These forms of protein oxidation can be reversed by methionine-S-sulfoxide reductase A (MSRA) and methionine-R-sulfoxide reductase B (MSRB), respectively.¹⁸ This is called the glutathione–methionine sulfoxide reductase (MSR) system.

Collective studies in both insects and animals have revealed that MSRA levels appear directly proportionate to oxidative resistance¹⁹ and that during the cellular aging process, MSRA/B activity is decreased, with an increase in the accumulation of oxidatively damaged proteins.^{18,19} MSRA activity has been detected in keratinocytes in all epidermal layers of human skin, as well as in sebaceous glands, eccrine glands, hair follicles, and the blood vessels of human skin, while certain subtypes of MSRB have been localized to melanocytes and blood vessels only.¹⁹ MSR was also found in fibroblasts, but has been less studied. The presence of MSR suggests significant oxidative protein stress in these cutaneous components requiring particularly efficient antioxidant repair mechanisms. Based on prior studies demonstrating UV-induced oxidative protein modifications in human skin, it is likely that inherent or acquired lack of MSRs may play an important role in photocarcinogenesis and photoaging.

Antioxidant activities are generally significantly higher in the epidermis than in the dermis. This reflects the fact that the epidermis is directly exposed to exogenous sources of oxidative stress and therefore might have evolved to possess a more pronounced antioxidant defense capacity than the dermis to counteract oxidative stress in skin.

Ascorbic acid, GSH, uric acid,²⁰ and vitamin E²¹ as well as catalase and superoxide dismutase^{22,23} have also been detected in the outermost epidermal layer, the human stratum corneum. On the other hand, GSH peroxidase and MSR activity were not detected in human stratum corneum.^{19,23} The distribution of the antioxidants found in the stratum corneum follows a gradient, with lower concentrations towards the skin's surface.²¹ Such a gradient may be explained by the fact that the outer skin layers are more directly exposed to environmental sources of ROS/RNS. Interestingly, while human stratum corneum concentrations of vitamin E are as high as in lower epidermal layers, concentrations of ascorbic acid and uric acid are in the range of 1–2 orders of magnitude lower (Thiele J and Packer L, unpublished observations).

Interestingly, in contrast to uric acid, GSH, and ubiquinol, ascorbic acid and the vitamin E homologs must be taken up in the diet since they cannot be formed by humans. Consequently, the skin's antioxidant defense is at least partially dependent on nutritive factors. The physiological regulation of ascorbic acid and vitamin E in skin is only recently becoming better understood. For instance, once ascorbic acid reaches skin via dermal blood vessels, it eventually enters the dermis where it is taken up by fibroblasts using a specific, sodium-dependent vitamin C transporter (SVCT2); or it may further diffuse through the dermis reaching the epidermis and supplying keratinocytes mainly via SVCT1.²⁴ As a significant constituent of human sebum, α -tocopherol is continuously secreted to the skin surface.²⁵ Similarly as for carotenoids,²⁶ sebaceous gland secretion is therefore believed to be a relevant physiological delivery pathway of α -tocopherol to sebaceous gland-rich skin regions, including facial skin. This may further explain the increased levels of α -tocopherol detected in the upper stratum corneum of facial skin as compared to upper arm skin.²¹ The physiological role of vitamin E in human sebum may be to limit the formation of toxic skin surface lipid photo-oxidation products, such as squalene monohydroperoxides.²⁷

In addition to its antioxidant activity, L-ascorbic acid is required as a co-factor in hydroxylation reactions during the formation of mature collagen, an important component of connective tissue,²⁸ and participates in biosynthesis of epidermal barrier lipids.²⁹

Effects of Environmental Stressors on Skin Antioxidants

Numerous studies have documented the effects of UVR on cutaneous antioxidants after acute or chronic exposure using different animal models.^{1,2} Far fewer studies investigating the mechanisms and consequences of such effects in humans have been conducted.^{1,2}

The antioxidants of the stratum corneum have been demonstrated to be particularly susceptible to UVR. For example, a single suberythemal dose of solar simulated UVR depleted human stratum corneum α -tocopherol by about half, while dermal and epidermal α -tocopherol were only depleted at significantly higher doses.²¹ The high susceptibility of stratum corneum vitamin E to UVR may be, at least in part, related to a lack of co-antioxidants in the outermost skin layer. The lipophilic antioxidant ubiquinone-10 (oxidized form of ubiquinol-10), the most abundant ubiquinol/ubiquinone found in human skin, is undetectable in human stratum corneum. Additionally, ascorbic acid, the major hydrophilic co-antioxidant that is also capable of recycling photooxidized α -tocopherol, is present at lower levels in *human* stratum

corneum than in other skin tissues. Because the stratum corneum represents a compartmentalized structure, the antioxidants are probably not homogeneously distributed. This may further affect their interactions and thus limit their capacity to recycle α -tocopherol. The hydrophilic antioxidants in the stratum corneum have also been shown to be sensitive to UVR.³⁰ However, it seems that ascorbic and uric acid are less susceptible to solar simulated UVR than α -tocopherol or ubiquinol-10, as demonstrated with cultured human skin models.³⁰ In full-thickness epidermis of hairless mice, however, ascorbic acid was depleted at lower solar UV-doses than those needed to deplete lipophilic antioxidants or GSH,³¹ and a human *in vivo* study showed that UV irradiated skin (vs. non-irradiated skin) resulted in a 66% reduction of ascorbic acid levels in the bloodstream.³² As demonstrated in another hairless mice study, epidermal GSH levels were significantly depleted within minutes after UVB exposure, but returned to normal levels after half an hour.³³ As further shown in mice, dermal and epidermal catalase is more susceptible to photo-inactivation by solar UVR than superoxide dismutase, and far more so than GSH-peroxidase and GSSG-reductase.^{34,35}

Effects of the air pollutant ozone on skin antioxidants have also been reported.^{1,2} Similarly to UVR exposure, the stratum corneum is the most susceptible skin layer for ozone-induced depletion of lipophilic and hydrophilic antioxidants. Ozone itself is too reactive to penetrate deeply into the skin and seems, therefore, to react predominantly with the skin barrier lipids and proteins in the outermost epidermis. Comparison of transepidermal water loss changes in hairless mice measured after exposure to either solar simulated UVR or repetitive high doses of ozone indicated that UVR is a physiologically more relevant source of oxidative stress than ozone for skin.³⁶

Changes in antioxidant enzyme activities and non-enzymatic antioxidant levels in human skin reveal a complex regulation of the antioxidant defense system during aging.³⁷ It has been demonstrated that α -tocopherol levels are significantly lower in the epidermis of photoaged and aged skin, but not in the dermis. Ascorbic acid levels are lower in both epidermis and dermis of photoaged and naturally aged skin, respectively. Total glutathione levels are also lower, whereas uric acid levels are constant in the epidermis and dermis, respectively. Moreover, protein oxidation is increased in intrinsically aged, and, most significantly, in photoaged human skin.²² It has been shown that oxidative damage is most pronounced in the papillary dermis, and correlates with solar elastosis. Protein oxidation and a drop in catalase protein levels were also found in the stratum corneum, but not in the lower epidermal layers.²² Accordingly, an age- and UVR-dependent decline of stratum corneum catalase has more recently been confirmed in the enzyme activity level.²³

Photoprotection of Human Skin by Topical Antioxidants

Apart from using sunscreens to limit solar UVR reaching the skin, supplementation of the skin with topically applied antioxidants, thereby strengthening its antioxidative capacity, is a well established approach in limiting skin damage secondary to oxidative stress.^{1,2,38,39} Oral supplementation of antioxidants, which is an emerging but less well understood strategy to prevent cutaneous photodamage, is not the subject of this chapter and is reviewed elsewhere.⁴⁰⁻⁴²

Topical application of antioxidants increases antioxidant tissue levels in skin. As the outermost and most susceptible skin layer for UVR- and air-pollutant-induced depletion of cutaneous antioxidants, the stratum corneum may particularly benefit from an increased antioxidant capacity via topical supplementation.

Vitamin E

The photoprotective effects of vitamin E (α -tocopherol) have been studied extensively. Whereas most studies have been performed in animals, several studies exist investigating the photoprotective effects of topically applied vitamin E also in humans.^{1,2,43} When vitamin E is applied before UVR exposure, significantly reduced acute skin responses are observed, including erythema and edema, sunburn cell formation, lipid peroxidation, DNA adduct formation, and immunosuppression, as well as UVA-induced binding of photosensitizers. As shown in animals, skin wrinkling and skin tumor incidence due to chronic UVR exposure are also diminished by topical vitamin E. A human study proved that an alcohol-based lotion of

2% α -tocopherol significantly diminished the erythral responses of skin redness and dermal blood flow when applied 30 minutes before UVR exposure.⁴⁴ Due to the fact that the lotion had no sunscreen properties, the observed photoprotective effects were attributed to the antioxidant properties of α -tocopherol. However, the photoprotective mechanism of action of α -tocopherol continues to be debated, since some studies have indicated that α -tocopherol may also act as a weak sunscreen.⁴⁵

Vitamin E esters, and in particular vitamin E acetate, have also been shown to reduce solar UVR-induced skin damage. Their photoprotective effects seem less pronounced compared to vitamin E; moreover, some studies have failed to show photoprotection by vitamin E esters. Vitamin E esters need to be hydrolyzed after skin absorption to act as antioxidants. Bioconversion of vitamin E acetate into the active form is slow and occurs only to a limited extent in skin. For instance, vitamin E acetate is not efficiently hydrolyzed in the stratum corneum and is converted to α -tocopherol only in the nucleated epidermis after penetration beyond the stratum corneum.⁴⁶ The controversial observations of photoprotective effects of topically applied vitamin E acetate may consequently be explained by a limited bioavailability of the active, ester-cleaved form at the site of oxidative stress. Intriguingly, the bioconversion of vitamin E acetate is enhanced when skin is exposed to sun, possibly by a UVB-dependent increase in esterase activity, as has been demonstrated in murine epidermis.⁴⁷

Vitamin C

Several studies investigated the photoprotective effects of topical vitamin C (ascorbic acid). Using a porcine skin model and applying 15% vitamin C in an aqueous solution adjusted to pH 3.2 with the help of semi-occlusive patches, vitamin C significantly protected from UVB-induced erythema and sunburn cell formation.⁴⁸ In a human study, however, a lower concentrated hydro-alcoholic lotion with 5% vitamin C did not induce any significant photoprotective effects when applied once 30 minutes before irradiation at a dose of 2 mg cm⁻².⁴⁴ Besides differences between pig and human skin responses, differences in vitamin C concentration, amount of formulation applied, vehicle composition as well as other experimental parameters may explain this difference in photoprotective efficacy of the vitamin C formulations.

Vitamin C is easily degraded by oxidation, which makes the development of a stable formulation challenging. Vitamin C can be stabilized in an aqueous formulation at low pH and under oxygen exclusion. Or, as described more recently, vitamin C can be kept stable in appropriate water-free, silicon-based vehicles.⁴⁹ Alternatively, esterified vitamin C derivatives such as magnesium or sodium ascorbyl phosphate, aminopropyl ascorbyl phosphate, and tetrahexyldecyl ascorbate (tetra-isopalmitate ascorbate) are stable and therefore promising alternatives to vitamin C.^{50,51} However, as described for vitamin E esters, these esters must be hydrolyzed to vitamin C to manifest antioxidant properties. In addition, some of those derivatives (e.g., tetrahexyldecyl ascorbate) are of significant higher molecular weight compared to vitamin C, which will affect their skin permeability.

Vitamin C does not act as a sunscreen, nor does it absorb UVA. In addition to its antioxidant properties, vitamin C participates in the formation of collagen as a co-factor of prolyl and lysyl hydroxylase, enzymes essential for the stabilizing and cross-linking of newly-formed collagen molecules. In humans, a six month use of a 5% vitamin C cream resulted in significantly improved skin relief and a decrease in deep furrows compared to placebo.⁵²

Polyphenols

Components of dietary and medical plants have gained considerable attention for protecting skin from UVR-induced photodamage after topical application.⁵³⁻⁵⁶ Extracts from green tea, wine grapes, coffee berry, feverfew, milk thistle, pomegranate, tropical ferns, and turmeric have been particularly studied. They contain a wide variety of polyphenols known as flavonoids, which are divided into flavonols, flavones, catechins, flavanones, anthocyanidins, and isoflavonoids depending on their chemical structure. They are synthesized conjointly with ascorbic acid, vitamin E, GSH, and numerous antioxidant enzymes by plants as a response to mitigate cellular damage due to oxidative conditions.

Polyphenols are generally multi-functional, strong antioxidants arising from (1) their high reactivity as hydrogen or electron donors, (2) the ability of the polyphenol-derived radical to stabilize the unpaired

electron, and (3) the ability to bind (i.e., chelate) transition metal ions such as Fe(II), thereby interfering with hydroxyl radical production.⁵⁷ Besides hydroxyl radicals, polyphenols are believed to quench singlet oxygen, superoxide anion radicals, and peroxy radicals. Moreover, polyphenolic compounds also possess anti-inflammatory and other properties beneficial for aged and damaged skin.

Green Tea Polyphenols

Green tea (*Camellia sinensis*) extracts are by far the most extensively studied polyphenolic antioxidants for skin.⁵⁸ In contrast to black tea, which is fermented, green tea leaves contain high levels of polyphenols such as epigallocatechin-gallate (EGCG). Green tea polyphenols act as antioxidants as described above; while green tea's major polyphenolic constituent, EGCG, additionally acts indirectly as an antioxidant through inhibition of "pro-oxidant" enzymes such as inducible nitric oxide synthase, lipoxygenases, and cyclooxygenases, and through the induction of antioxidant enzymes GSH-S-transferases and SOD.⁵⁷

Protective effects of green tea extracts and EGCG on UVR-induced skin damage after topical application were first observed in animals.⁵⁸ Later, these effects were confirmed in humans, where topical application of green tea extracts or EGCG significantly decreased erythema, lipid peroxidation, and DNA-damage.^{59,60} A placebo-controlled study with 40 women with moderate photoaging demonstrated that a 10% green tea cream with an oral green tea supplementation (300 mg) resulted in a significant improvement in elastic tissue after eight weeks of twice daily combined use.⁶¹ A trend toward improvement in clinical grading was observed between green tea and placebo treated groups, indicating that a longer treatment period may be required for clinically relevant improvements. In another placebo-controlled study, topical application of a green tea protected human skin from solar-simulated UV light when applied 15 minutes prior to exposure and reapplied immediately after exposure to two minimum erythema doses.⁶² However, this study did not reveal any difference between green and white tea extracts. Another study revealed that three times daily use of a lotion with 0.4% of a green tea extract of 40%–50% total polyphenol content reduced UVB-mediated increase in sunburn cell formation (apoptotic keratinocytes) and p53 expression in keratinocytes; while not decreasing erythema and thymidine dimer formation.⁶³ This latter study clearly indicated that topical formulations are efficient for photoprotection of skin starting at a relatively low concentration of green tea extract (i.e., providing about 0.2% total polyphenols).

Whereas green tea extracts and EGCG have also been described to have chemoprotective effects in rodents and prevent cancers, including non-melanoma skin cancer, epidemiologic and human studies are so far inconclusive.^{58,64}

Other Polyphenols

The coffee berry, the unripe coffee bean, contains diverse (poly)phenolic compounds including chlorogenic acid, quinic acid, ferulic acid, and condensed proanthocyanidins. In a clinical study, a skincare regimen with 1% coffee berry extract resulted in a significant improvement in signs of skin aging compared to vehicle.⁶⁵ Pomegranate fruit extract comprising the polyphenol ellagic acid possessed strong antioxidant and anti-inflammatory properties and limited UVB-mediated damage in a human reconstituted skin model.⁶⁶ Another natural extract, a parthenolide-depleted extract of feverfew, has free radical scavenging activity against a wide range of ROS. In a clinical study, topical feverfew treatment significantly reduced erythema versus placebo 24 hours after UV exposure.⁶⁷ Topical silymarin, a milk thistle extract containing silybinin as the predominant polyphenol, inhibited UVB-induced immunosuppression, reduced UVB-induced sunburn cell formation, and prevented DNA adduct formation and photocarcinogenesis in mice.^{68,69} Genistein, a major flavonoid constituent of soybean, acts as a phytoestrogen and tyrosine kinase inhibitor, but also possesses antioxidant properties. Topical administration of genistein inhibited UVR-induced hydrogen peroxide formation, lipid peroxidation, and DNA-damage in mice, and protected human skin against UVB-induced erythema.⁷⁰ A study evaluating phenolic plant extracts in humans revealed that topical application of a tropical fern extract reduced erythema as well as UVA-induced immediate pigment darkening, and delayed tanning when applied before UVR exposure.⁷¹

Complementary studies are warranted in order to help verify whether the observed beneficial effects of the botanical extracts or their constituents may not be at least partially related to their sunscreensing

properties under the respective study conditions (e.g., UVR-source, concentration, and dose of extract applied per surface area).

Thiol Antioxidants

Thiol antioxidants including GSH, N-acetylcysteine, and lipoic acid are another important group of radical scavengers.^{1,2} Topical administration of GSH, GSH-ethyl ester, and N-acetylcysteine, respectively, efficiently protected against UVB-radiation induced epidermal lipid peroxidation, cytotoxicity, and apoptosis in a pig skin *ex vivo* model.⁷²

Few studies reported about the photoprotective effects of thiol antioxidants in humans. Topical treatment with N-acetylcysteine under occlusion resulted in an increased GSH level and eliminated its oxidized form (GSSG) in human skin *in vivo*.⁷³ Thus, in addition to its direct antioxidant properties, stimulation of GSH-biosynthesis seems a key mechanism for the observed photoprotective effects of N-acetylcysteine. In addition, dihydrolipoic acid, the reduced and primarily active antioxidant form of α -lipoic acid, is another thiol-antioxidant limiting oxidative stress. A placebo-controlled, split-face study indicated that several clinical characteristics related to photoaging of facial skin improved after application of a 5% lipoic acid cream over 12 weeks.⁷⁴

Other Antioxidants

The pineal hormone melatonin (N-acetyl-5-methoxytryptamine) has antioxidant properties and significantly reduced UVR-induced erythema in humans.⁴⁴ Together with its antioxidant properties, the dose-dependent sunscreensing properties, as well as the immunomodulatory function of melatonin, might have contributed to the observed photoprotective effects. In addition, L-ergothioneine, which is a thio-urea derivative of histidine found in food plants and mushrooms, is another promising antioxidant.⁷⁵ Idebenone, a synthetic analog of coenzyme Q, which is presumed to penetrate skin better than its parent compound, is another antioxidant, as has been shown *in vitro*.⁷⁶ A clinical study with a 1% idebenone formulation demonstrated a reduction in fine lines/wrinkles in female subjects.⁷⁷ However, a study in pigs indicated that idebenone is without photoprotective effects.⁷⁸

Antioxidant Combinations

Antioxidants interact, and emanating radical or oxidized forms of antioxidants after ROS/RNS scavenging are regenerated in the presence of appropriate co-antioxidants. Accordingly, a significantly enhanced photoprotective effect may be obtained by distinct combinations of antioxidants. For instance, ample evidence exists about the interactive dependence of vitamins C and E in diminishing photodamage *in vivo*.

As was shown in a human study, a single topical application of a combination of 2% vitamin E and 5% vitamin C resulted in higher photoprotection when compared to either antioxidant alone in an identical vehicle.⁴⁴ The same study revealed that the most dramatic improvement resulted from the co-formulation of melatonin together with α -tocopherol and ascorbic acid. Possible synergistic interactions between melatonin and vitamins E and C may have contributed to the significantly increased photoprotective effects.

Other distinct mixtures of topical antioxidants have further been shown to be more effective in reducing photodamage as compared to single antioxidants. Adding 0.5% ferulic acid to a solution of 1% α -tocopherol and 15% ascorbic acid doubled its photoprotection (erythema, sunburn cells) in pigs from four- to eightfold.⁷⁹ The same antioxidant combination was recently shown to prevent more malignant skin tumors in female mice with chronically UVB-damaged skin compared to topical vitamin E alone.⁸⁰ Furthermore, the combination of ferulic acid with tocopheryl acetate and α -glycosylrutin limited the severity of polymorphous light eruptions when applied prior to photoprovocation with UVA in humans.⁸¹ However, since ferulic acid significantly absorbs in the UVB/A-range and has, therefore, sunscreensing properties, the photoprotection observed in those studies cannot be solely attributed to its antioxidant properties.⁸² Remarkably strong antioxidant effects were found for a mixture of ascorbic acid, α -tocopherol, and green tea polyphenols.⁸³ Kinetic and mechanistic *in vitro* studies revealed that those antioxidants acted in synergy as a result of the regeneration of α -tocopherol through the green tea

polyphenols, which were regenerated by ascorbic acid. Consequently, the antioxidant synergism between the green tea polyphenols (i.e., ECGC), ascorbic acid, and α -tocopherol makes this combination particularly interesting for antioxidant protection.

Evaluating Antioxidants

In the discussions about antioxidants, the question often arises about how to determine the capacity of antioxidants or antioxidant combinations to eliminate ROS/RNS. Accurate quantification of antioxidant capacity is, however, a challenging task, and there is currently no single assay available that can sufficiently meet it. The use of assays for this purpose have recently been reviewed by Chen and Wang.⁸⁴

Oxygen radical absorbance capacity (ORAC) is currently the most well-known antioxidant assay. It was developed by the food industry to measure the antioxidant potential of foods. The assay uses a fluorescence probe that is susceptible to oxidation by free radicals. Despite being widely known, this method of measuring antioxidant capacity has significant limitations.

Electron spin resonance (ESR)-spectroscopy-based assays have several important advantages over other assays and are, therefore, becoming more widely used.⁸⁵ ESR allows direct detection and quantification of free radicals, in contrast to ORAC (and similar de-colorization assays), which requires the addition of a fluorescent probe. Therefore, the ESR method provides an accurate measure of the antioxidant capacity. In addition, only ESR-spectroscopy can be performed with colored or opaque preparations, and in skin.^{84,85}

Antioxidants and Sunscreens

Along with sun avoidance the use of sunscreen is the most widely adopted strategy by the public for efficient protection from the sun's UVR. But the question remains: How good are broad-spectrum sunscreens in limiting free radical formation? It has been shown that sunscreens with broad-spectrum UV protection can reduce free radical formation by 55%.⁸⁶ Using ESR methodologies, a correlation between protection from UVA and protection from free radical formation has been measured with multiple sunscreens.⁸⁷ This observation indicates that a sunscreen product with high UVA protection reduces the amount of free radicals generated in skin more than a sunscreen with a low UVA protection. Yet, the majority of sunscreens currently on the market provide more UVB than UVA protection, and consequently offer only relatively moderate protection against UVA-induced ROS/RNS.

Therefore, the addition of antioxidants to sunscreens is an attractive approach to help quench ROS/RNS generated by UVR that has passed the sunscreen filters. Despite the promising nature of this photoprotection strategy, the benefits of the addition of antioxidants to sunscreens to enhance protection from oxidative stress requires further elucidation. For instance, whereas Darr and coworkers⁸⁸ first demonstrated in 1996 that vitamins C and E combined with oxybenzone resulted in greater than additive protection against phototoxic damage in pigs, Wang and coworkers⁸⁹ reported that the radical protection in human skin was almost entirely from the sunscreen (specifically UVA filters in the sunscreen) and not from the antioxidants. This latter study, however, was realized with sunscreen formulations which are less modern or contain only relatively low amounts of antioxidants compared to the newer or more innovative sunscreen formulations with higher levels of antioxidants that are currently being researched. For instance, a study compared a sunscreen with SPF 25 (SS) with the same sunscreen containing additionally an antioxidant mixture of vitamin C, vitamin E, and a few other ingredients with potential antioxidant properties (SS + AO).⁹⁰ After the skin was exposed to UVR, the SS + AO group had a 17% greater reduction in MMP-1 levels when compared with the SS group. Both SS and SS + AO also protected against the depletion of Langerhans cells. A similar study design with a comparable antioxidant preparation also containing vitamins C and E found that SS + AO significantly protected against MMP-9 induction, pigment formation, and markers associated with epidermal hyperproliferation, compared to sunscreens or antioxidants alone.⁹¹ This newer data add to the emerging knowledge that antioxidants can indeed provide additional benefits to sunscreens.

Non-Conventional Antioxidants

Apart from increasing the skin's antioxidant capacity by topical application of antioxidants, other chemicals can enhance its antioxidative capacity by preventing the formation of ROS/RNS, or by increasing the formation, stability, and activity of constitutive skin antioxidants.

Skin contains substantial amounts of iron, levels of which increase as a result of chronic exposure to UVR.⁹² Iron is a catalyst in the formation of the highly reactive and damaging hydroxyl radical, which explains why the topical use of iron chelators (e.g., 2-furildioxime) provide some photoprotection alone⁹³ or in combination with sunscreens.⁹⁴ Furthermore, topical application of 1,25-dihydroxy-vitamin D₃ induced the formation of metallothionein and reduced sunburn cell formation in mouse skin after UVB-exposure.⁹⁵ The authors suggested that the cysteine-rich metallothionein acts as a radical scavenger.

In addition, creatine supplementation has been shown to limit mitochondrial oxidative stress and normalize the mutagenesis of mitochondrial DNA induced by UVA in human fibroblasts, independent of antioxidant mechanisms.¹⁰ Niacinamide has been shown to enhance the antioxidant capacity of skin after topical application by increasing NADPH, which has antioxidant properties.⁹⁶

Selenium, an essential trace element in humans and animals, is the required constituent for GSH-peroxidase. Applying topical selenium in the form of L-selenomethionine reduces acute and/or chronic skin damage in humans.^{97,98} Whereas topical application of L-selenomethionine leads to increased skin selenium levels, free selenium is apparently not absorbed. Another metal, zinc, also has antioxidant functions and has shown photo-protective effects after topical application.⁹⁹

Concluding Comments

Numerous animal and human studies have convincingly demonstrated that topical antioxidants help limit UV-induced skin damage. In humans, the protective effects have been particularly well studied for ascorbic acid, tocopherol, ferulic acid, and a few natural polyphenolic antioxidant mixtures including green tea extracts rich in EGCG. The efficacy of antioxidants is significantly increased when applied in combination. The combination of ascorbic acid, tocopherol, and ferulic acid, or the combination of ascorbic acid, tocopherol, and green tea extract or EGCG, are particularly potent, synergistic, antioxidant combinations. Accordingly, regular use of skin care products with such antioxidants can efficiently protect skin against exogenous and endogenous oxidative stressors occurring during daily life.

However, formulating products with antioxidant properties is not simple, and a number of technical requirements must be fulfilled for an efficient product. First, antioxidants should have a high antioxidative capacity and be present in relevant concentrations. Second, antioxidants need to be stable in the final formulation; in general, antioxidants are inherently unstable. In the case of vitamin E and C, stable forms as esters (tocopheryl acetate, sodium ascorbyl phosphate, etc.) can be used as substitutes. However, these substitutes have a lower biological activity, since they need to be hydrolyzed (spontaneously, or with the help of esterases in the skin) before manifesting antioxidant properties. Other antioxidants, such as ubiquinone, idebenone, and kinetin have been shown to be quickly degraded upon UV exposure. Third, antioxidants need to penetrate into and through the stratum corneum and maintain adequate concentrations in the epidermis and ideally also in the dermis to provide relevant antioxidant efficacy.

When comparing potency between different antioxidant products, the comparison should be preferentially based on clinical data or ESR-based methods, since most other *in vitro* tests, including ORAC, provide only limited information and may be prone to error.

Since sunlight-induced skin damage also occurs through non-oxidative stress related mechanisms, antioxidant supplementation will not provide complete photoprotection. In fact, the photoprotective effects of most antioxidants are relatively modest compared to broadband sunscreen products. Therefore, while antioxidants provide additional benefits to sunscreens, sunscreens are indispensable in the effective prevention of skin photodamage. In contrast to antioxidants, it is desirable to keep sunscreens on the skin surface and limit their penetration into and through the skin. Those conflicting goals for delivering antioxidants and UV filters create additional challenges for the formulators of skin care products.

It is important to keep in mind that antioxidants are of a protective nature (i.e., from oxidative stress) and, except L-ascorbic acid, generally have no effect in reversing existing skin wrinkles. Only agents which promote collagen formation, such as retinoic acid, a few distinct peptides, and human growth factors, such as basic fibroblast growth factor or transforming growth factors beta, have been shown to reverse to some extent the signs of skin aging.¹⁰⁰

REFERENCES

1. Thiele J, Elsner P. Oxidants and antioxidants in cutaneous biology. In: Burg G, ed. *Current Problem in Dermatology*. Basel: Karger, 2001. p. 29.
2. Dreher F, Thiele JJ. Antioxidants. In: Baran R, Maibach HI, eds. *Textbook of Cosmetic Dermatology*, 4th edn. Boca Raton, FL: CRC Press, 2010. p. 115–22.
3. Krutmann J, Schroeder P. Role of mitochondria in photoaging of human skin: The defective powerhouse model. *J Invest Dermatol Symp Proc* 2009;14:44–9.
4. Chang H, Oehrl W, Elsner P et al. The role of H₂O₂ as a mediator of UVB induced apoptosis in keratinocytes. *Free Radic Res* 2003;37:655–63.
5. Berneburg M, Gattermann N, Stege H et al. Chronically ultraviolet-exposed human skin shows a higher mutation frequency of mitochondrial DNA as compared to unexposed skin and the hematopoietic system. *Photochem Photobiol* 1997;66:271–5.
6. Lenaz G. Role of mitochondria in oxidative stress and ageing. *Biochim Biophys Acta* 1998;1366:53–67.
7. DiMauro S, Tanji K, Bonilla E, Pallotti F, Schon EA. Mitochondrial abnormalities in muscle and other aging cells: Classification, causes, and effects. *Muscle Nerve* 2002;26:597–607.
8. Jacobs HT. The mitochondrial theory of aging: Dead or alive? *Aging Cell* 2003;2:11–7.
9. Pak JW, Herbst A, Bua E et al. Rebuttal to Jacobs: The mitochondrial theory of aging: Alive and well. *Aging Cell* 2003;2:9–10.
10. Berneburg M, Gremmel T, Kürten V et al. Creatine supplementation normalizes mutagenesis of mitochondrial DNA as well as functional consequences. *J Invest Dermatol* 2005;125:213–20.
11. Yang JH, Lee HC, Lin KJ, Wei YH. A specific 4977-bp deletion of mitochondrial DNA in human ageing skin. *Arch Dermatol Res* 1994;286:386–90.
12. Birch-Machin MA, Tindall M, Turner R, Haldane F, Rees JL. Mitochondrial DNA deletions in human skin reflect photo-rather than chronologic aging. *J Invest Dermatol* 1998;110:149–52.
13. Koch H, Wittern KP, Bergemann J. In human keratinocytes the common deletion reflects donor variabilities rather than chronologic aging and can be induced by ultraviolet A irradiation. *J Invest Dermatol* 2001;117:892–7.
14. Berneburg M, Plettenberg H, Medve-Konig K et al. Induction of the photoaging-associated mitochondrial common deletion *in vivo* in normal human skin. *J Invest Dermatol* 2004;122:1277–83.
15. Shindo Y, Witt E, Han D et al. Enzymic and non-enzymic antioxidants in epidermis and dermis of human skin. *J Invest Dermatol* 1994;102:122–4.
16. Schallreuter KU, Wood JM. Thioredoxin reductase—Its role in epidermal redox status. *J Photochem Photobiol B* 2001;64:179–84.
17. Taungjaruwina WM, Bhawan J, Keady M et al. Differential expression of the antioxidant repair enzyme methionine sulfoxide reductase (MSRA and MSRB) in human skin. *Am J Dermatopathol* 2009;31:427–31.
18. Moskovitz J. Methionine sulfoxide reductases: Ubiquitous enzymes involved in antioxidant defense, protein regulation, and prevention of aging-associated diseases. *Biochim Biophys Acta* 2005;1703:213–9.
19. Ogawa F, Sander CS, Hansel A et al. The repair enzyme peptide methionine-S-sulfoxide reductase is expressed in human epidermis and upregulated by UVA radiation. *J Invest Dermatol* 2006;126:1128–34.
20. Weber SU, Thiele JJ, Cross CE et al. Vitamin C, uric acid and glutathione gradients in murine stratum corneum and their susceptibility to ozone exposure. *J Invest Dermatol* 1999;113:1128–32.
21. Thiele JJ, Traber MG, Packer L. Depletion of human stratum corneum vitamin E: An early and sensitive *in vivo* marker of UV-induced photooxidation. *J Invest Dermatol* 1998;110:756–61.
22. Sander CS, Chang H, Salzmann S et al. Photoaging is associated with protein oxidation in human skin *in vivo*. *J Invest Dermatol* 2002;118:618–25.
23. Hellemans L, Corstjens H, Neven A et al. Antioxidant enzyme activity in human stratum corneum shows seasonal variation with an age-dependent recovery. *J Invest Dermatol* 2003;120:434–9.

24. Steiling H, Longet K, Moodycliffe A et al. Sodium-dependent vitamin C transporter isoforms in skin: Distribution, kinetics, and effect of UVB-induced oxidative stress. *Free Radic Biol Med* 2007;43:752–62.
25. Thiele JJ, Weber SU, Packer L. Sebaceous gland secretion is a major physiological route of vitamin E delivery to skin. *J Invest Dermatol* 1999;113:1006–10.
26. Darwin ME, Fluhr JW, Caspers P et al. *In vivo* distribution of carotenoids in different anatomical locations of human skin: Comparative assessment with two different Raman spectroscopy methods. *Exp Dermatol* 2009;18(12):1060–3.
27. Ekanayake Mudiyansele S, Hamburger M, Elsner P et al. UVA induces generation of squalene monohydroperoxide isomers in human sebum and skin surface lipids *in vitro* and *in vivo*. *J Invest Dermatol* 2003;120(6):915–22.
28. Davidson JM, LuValle PA, Zoia O et al. Ascorbate differentially regulates elastin and collagen biosynthesis in vascular smooth muscle cells and skin fibroblasts by pretranslational mechanisms. *J Biol Chem* 1997;272:345–52.
29. Ponc M, Weerheim A, Kempenmaer J et al. The formation of competent barrier lipids in reconstructed human epidermis requires the presence of vitamin C. *J Invest Dermatol* 1997;109:348–55.
30. Podda M, Traber MG, Weber C et al. UV-irradiation depletes antioxidants and causes oxidative damage in a model of human skin. *Free Radic Biol Med* 1998;24:55–65.
31. Shindo Y, Witt E, Han D et al. Recovery of antioxidants and reduction in lipid hydroperoxides in murine epidermis and dermis after acute ultraviolet radiation exposure. *Photodermatol Photoimmunol Photomed* 1994;10:183–91.
32. Colven RM, Pinnel SR. Topical vitamin C in aging. *Clin Dermatol* 1996;14:227–34.
33. Connor MJ, Wheeler LA. Depletion of cutaneous glutathione by ultraviolet radiation. *Photochem Photobiol* 1987;46:239–45.
34. Shindo Y, Witt E, Packer L et al. Antioxidant defense mechanisms in murine epidermis and dermis and their responses to ultraviolet light. *J Invest Dermatol* 1993;100:260–5.
35. Shindo Y, Witt E, Han D et al. Dose-response effects of acute ultraviolet irradiation on antioxidants and molecular markers of oxidation in murine epidermis and dermis. *J Invest Dermatol* 1994;102:470–5.
36. Thiele JJ, Dreher F, Maibach HI et al. Impact of ultraviolet radiation and ozone on transepidermal water loss as a function of skin temperature in hairless mice. *Skin Pharmacol Appl Skin Physiol* 2003;16:283–90.
37. Rhie G, Shin MH, Seo JY et al. Aging- and photoaging-dependent changes of enzymic and nonenzymic antioxidants in the epidermis and dermis of human skin *in vivo*. *J Invest Dermatol* 2001;117:1212–7.
38. Pinnel SR. Cutaneous photodamage, oxidative stress, and topical antioxidant protection. *J Am Acad Dermatol* 2003;48:1–19.
39. Chen L, Hu JY, Wang SQ. The role of antioxidants in photoprotection: A critical review. *J Am Acad Dermatol* 2012;67:1013–24.
40. Fuchs J. Potentials and limitations of the natural antioxidants RRR- α -tocopherol, L-ascorbic acid and β -carotene in cutaneous photoprotection. *Free Radic Biol Med* 1998;25:848–73.
41. Boelsma E, Hendriks HFJ, Roza L. Nutritional skin care: Health effects of micronutrients and fatty acids. *Am J Clin Nutr* 2001;73:853–64.
42. Bialy TL, Rothe MJ, Grant-Kels JM. Dietary factors in the prevention and treatment of nonmelanoma skin cancer and melanoma. *Dermatol Surg* 2002;28:1143–52.
43. Thiele JJ, Ekanayake-Mudiyansele S. Vitamin E in human skin: Organ-specific physiology and considerations for its use in dermatology. *Mol Aspects Med* 2007;28:646–67.
44. Dreher F, Gabard B, Schwindt DA et al. Topical melatonin in combination with vitamins E and C protects skin from UV-induced erythema: A human study *in vivo*. *Br J Dermatol* 1998;139:332–9.
45. Kramer KA, Liebler DC. UVB induced photooxidation of vitamin E. *Chem Res Toxicol* 1997;10:219–24.
46. Baschong W, Artmann C, Hueglin D et al. Direct evidence for bioconversion of vitamin E acetate into vitamin E: An *ex vivo* study in viable human skin. *J Cosmet Sci* 2001;52:155–61.
47. Kramer-Stickland KA, Liebler DC. Effect of UVB on hydrolysis of α -tocopherol acetate to α -tocopherol in mouse skin. *J Invest Dermatol* 1998;111:302–7.
48. Darr D, Combs S, Dunston S et al. Topical vitamin C protects porcine skin from ultraviolet radiation-induced damage. *Br J Dermatol* 1992;127:247–53.
49. Wang JJ, Hung JL, Hrubec TJ, Granatell D. Topical cosmetic composition containing hybrid silicone composite powder. United States Patent Application US 2005-0112072.

50. Stamford NP. Stability, transdermal penetration, and cutaneous effects of ascorbic acid and its derivatives. *J Cosmet Dermatol* 2012;11:310–7.
51. Farris PK. Topical vitamin C: A useful agent for treating photoaging and other dermatologic conditions. *Dermatol Surg* 2005;31:814–7.
52. Humbert PG, Haftek M, Creidi P et al. Topical ascorbic acid on photoaged skin. Clinical, topographical and ultrastructural evaluation: Double-blind study vs. placebo. *Exp Dermatol* 2003;12:237–44.
53. Afaq F, Mukhtar H. Photochemoprevention by botanical antioxidants. *Skin Pharmacol Appl Skin Physiol* 2002;15:297–306.
54. Berson DS. Natural antioxidants. *J Drugs Dermatol* 2008;7(7 Suppl):s7–12.
55. Baumann L, Woolery-Lloyd H, Friedman A. “Natural” ingredients in cosmetic dermatology. *J Drugs Dermatol* 2009;8(6 Suppl):s5–9.
56. Ditre C, Wu J, Baumann LS et al. Innovations in natural antioxidants and their role in dermatology. *Cutis* 2008;82(6 Suppl):2–16.
57. Frei B, Higdon JV. Antioxidant activity of tea polyphenols *in vivo*: Evidence from animal studies. *J Nutr* 2003;133:3275S–84S.
58. Hsu S. Green tea and the skin. *J Am Acad Dermatol* 2005;52:1049–59.
59. Katiyar SK, Afaq F, Perez A et al. Green tea polyphenol (-)-epigallocatechin-3-gallate treatment of human skin inhibits ultraviolet radiation-induced oxidative stress. *Carcinogenesis* 2001;22:287–94.
60. Elmets CA, Singh D, Tubesing K et al. Cutaneous photoprotection from ultraviolet injury by green tea polyphenols. *J Am Acad Dermatol* 2001;44:425–32.
61. Chiu AE, Chan JL, Kern DF et al. Double-blinded, placebo-controlled trial of green tea extracts in the clinical and histologic appearance of photoaging skin. *Dermatol Surg* 2005;3:855–60.
62. Camouse MM, Domingo DS, Swain FR et al. Topical application of green and white tea extracts provides protection from solar-simulated ultraviolet light in human skin. *Exp Dermatol* 2009;18:522–6.
63. Mnich CD, Hoek KS, Virkki LV et al. Green tea extract reduces induction of p53 and apoptosis in UVB-irradiated human skin independent of transcriptional controls. *Exp Dermatol* 2009;18:69–77.
64. Boehm K, Borrelli F, Ernst E et al. Green tea (*Camellia sinensis*) for the prevention of cancer. *Cochrane Database Syst Rev* 2009;8(3):CD005004.
65. Farris P. Idebenone, green tea, and Coffeeberry® extract: New and innovative antioxidants. *Dermatol Ther* 2007;20:322–9.
66. Afaq F, Zaid MA, Khan N et al. Protective effect of pomegranate-derived products on UVB-mediated damage in human reconstituted skin. *Exp Dermatol* 2009;18:553–61.
67. Martin K, Sur R, Liebel F et al. Parthenolide-depleted Feverfew (*Tanacetum parthenium*) protects skin from UV irradiation and external aggression. *Arch Dermatol Res* 2008;300:69–80.
68. Singh RP, Agarwal R. Flavonoid antioxidant silymarin and skin cancer. *Antioxid Redox Signal* 2002;4:655–63.
69. Saller R, Melzer J, Reichling J et al. An updated systematic review of the pharmacology of silymarin. *Forsch Komplementmed* 2007;14:70–80.
70. Wei H, Saladi R, Lu Y et al. Isoflavone genistein: Photoprotection and clinical implications in dermatology. *J Nutr* 2003;133:3811S–19S.
71. González S, Pathak MA, Cuevas J et al. Topical or oral administration with an extract of *Polypodium leucotomos* prevents acute sunburn and psoralen-induced phototoxic reactions as well as depletion of Langerhans cells. *Photodermatol Photoimmunol Photomed* 1997;13:50–60.
72. Rijnkels JM, Moison RMW, Podda E et al. Photoprotection by antioxidants against UVB-radiation-induced damage in pig skin organ culture. *Radiat Res* 2003;159:210–7.
73. Kang S, Chung JH, Lee JH et al. Topical N-acetyl cysteine and genistein prevent ultraviolet-light-induced signaling that leads to photoaging in human skin *in vivo*. *J Invest Dermatol* 2003;120:835–41.
74. Beitner H. Randomized, placebo-controlled, double blind study on the clinical efficacy of a cream containing 5% alpha-lipoic acid related to photoaging of facial skin. *Br J Dermatol* 2003;149:841–9.
75. Dong KK, Damaghi N, Kibitel J et al. A comparison of the relative antioxidant potency of L-ergothioneine and idebenone. *J Cosmet Dermatol* 2007;6:183–8.
76. McDaniel DH, Neudecker BA, Dinardo JC et al. Idebenone: A new antioxidant—Part I. Relative assessment of oxidative stress protection capacity compared to commonly known antioxidants. *J Cosmet Dermatol* 2005;4:10–7.

77. McDaniel D, Neudecker B, Dinardo J et al. Clinical efficacy assessment in photodamaged skin of 0.5% and 1% idebenone. *J Cosmet Dermatol* 2005;4:167–73.
78. Tournas JA, Lin FH, Burch JA et al. Ubiquinone, idebenone, and kinetin provide ineffective photoprotection to skin when compared to a topical antioxidant combination of vitamins C and E with ferulic acid. *J Invest Dermatol* 2006;126:1185–7.
79. Lin FH, Lin JY, Gupta RD et al. Ferulic acid stabilizes a solution of vitamins C and E and doubles its photoprotection of skin. *J Invest Dermatol* 2005;125:826–32.
80. Burns EM, Tober KL, Riggenbach JA et al. Differential effects of topical vitamin E and C E Ferulic® treatments on ultraviolet light B-induced cutaneous tumor development in skh-1 mice. *PLoS One* 2013;8(5):e63809.
81. Hadshiew I, Stäb F, Untiedt S et al. Effects of topically applied antioxidants in experimentally provoked polymorphous light eruption. *Dermatology* 1997;195:362–8.
82. Graf E. Antioxidant potential of ferulic acid. *Free Radic Biol Med* 1992;13:435–48.
83. Dai F, Chen WF, Zhou B. Antioxidant synergism of green tea polyphenols with α -tocopherol and L-ascorbic acid in SDS micelles. *Biochemie* 2008;90:1499–505.
84. Chen LL, Wang SQ. From the bottle to the skin: Challenges in evaluating antioxidants. *Photodermatol Photoimmunol Photomed* 2012;28:228–34.
85. Herrling T, Jung K. The Radical Status Factor (RSF): A novel metric to characterize skin products. *Int J Cosmet Sci* 2012;34:285–90.
86. Haywood R, Wardman P, Sanders R, Linge C. Sunscreens inadequately protect against ultraviolet-A-induced free radicals in skin: Implications for skin aging and melanoma? *J Invest Dermatol* 2003;121:862–8.
87. Wang SQ, Osterwalder U, Jung K. *Ex vivo* evaluation of radical sun protection factor in popular sunscreens with antioxidants. *J Am Acad Dermatol* 2011;65:525–30.
88. Darr D, Dunston S, Faust H et al. Effectiveness of antioxidants (vitamin C and E) with and without sunscreens as topical photoprotectants. *Acta Derm Venereol* 1996;76:264–8.
89. Wang SQ, Stanfield JW, Osterwalder U. *In vitro* assessments of UVA protection by popular sunscreens available in the United States. *J Am Acad Dermatol* 2008;59:934–42.
90. Matsui MS, Hsia A, Miller JD et al. Non-sunscreen photoprotection: Antioxidants add value to a sunscreen. *J Invest Dermatol Symp Proc* 2009;14:56–9.
91. Wu Y, Matsui MS, Chen JZ et al. Antioxidants add protection to a broad-spectrum sunscreen. *Clin Exp Dermatol* 2011;36:178–87.
92. Bissett DL, Chatterjee R, Hannon DP. Chronic ultraviolet radiation-induced increase in skin iron and the photoprotective effect of topically applied iron chelators. *Photochem Photobiol* 1991;54:215–23.
93. Bissett DL, Oelrich DM, Hannon DP. Evaluation of a topical iron chelator in animals and in human beings: Short-term photoprotection by 2-furildioxime. *J Am Acad Dermatol* 1994;31:572–8.
94. Bissett DL, McBride JF. Synergistic topical photoprotection by a combination of the iron chelator 2-furildioxime and sunscreen. *J Am Acad Dermatol* 1996;35:546–9.
95. Hanada K, Sawamura D, Nakano H, Hashimoto I. Possible role of 1,25-dihydroxyvitamin D₃-induced metallothionein in photoprotection against UVB injury in mouse skin and cultured rat keratinocytes. *J Dermatol Sci* 1995;9:203–8.
96. Levin J, Momin SB. How much do we really know about our favorite cosmeceutical ingredients? *J Clin Aesthet Dermatol* 2010;3:22–41.
97. Burke KE, Combs GF, Gross EG, Bhuyan KC, Abu-Libdeh H. The effects of topical and oral L-selenomethionine on pigmentation and skin cancer induced by ultraviolet irradiation. *Nutr Cancer* 1992;17:123–37.
98. Burke KE, Bedford RG, Combs GF, French IW, Skeffington DR. The effect of topical L-selenomethionine on minimal erythema dose of ultraviolet irradiation in humans. *Photodermatol Photoimmunol Photomed* 1992 9:52–7.
99. Rostan EF, DeBuys HV, Madey DL, Pinnell SR. Evidence supporting zinc as an important antioxidant for skin. *Int J Dermatol* 2002;41:606–11.
100. Rangarajan V, Dreher F. Topical growth factors for skin rejuvenation. In: Farage MA, Maibach HI, Miller KW, eds. *Textbook of Skin Aging*. New York: Springer, 2010.

17

Decorative Cosmetics

Giorgiana Giancola and Mitchell L. Schlossman

Introduction

Decorative cosmetics are primarily associated with imparting visual aspects to a finished product. Recently, functionality has become a secondary role; for instance, an effect pigment which enhances feel in formulation. Color is a primary component of decorative cosmetics and can easily enamor a customer into buying a visually appealing product.

From a scientific perspective, pigments create colors by absorption of particular wavelengths of incident light. The color that an individual perceives corresponds to the wavelengths that are reflected from a particular object. Each color has its own unique wavelength and the human eye has the ability to discern only a fraction of the magnetic spectrum, known as visible light. Lower wavelengths encompass radio, microwave, and infrared, while higher frequencies include ultraviolet (UV), x-ray, and gamma rays.

Generating decorative cosmetics is a challenge for chemists from a formulation perspective but also from a regulatory perspective since these types of parameters vary from country to country, depending on where the finished goods are sold. In recent years, niche areas of color cosmetics have been developed, with particular interest in the incorporation of treatment actives best referred to as cosmeceuticals. Niche areas of color cosmetics include the addition of UV filters, herbs, vitamins, and moisturizers with the ultimate goals such as limiting the effects of aging and imparting moisture to the skin. This chapter encompasses an array of topics to serve as a guide for technical and regulatory-related issues in a straightforward format.

Color Chemistry

The human eye cannot perceive all wavelengths of light, only waves that fall in the range of about 400–800 nm. With this said, light is selectively absorbed by materials depending on their chemical constitution. Molecules exist in varying electronic states and provided they contain more than one nuclei they will also possess energies of rotation and vibration; this applies to both organic and inorganic colorants. Organic materials mostly absorb in the UV region of the electromagnetic spectrum and therefore appear colorless. In the case of inorganic colorants, these colored compounds are obtained with the ions of transition elements with atomic numbers 22–29. Ultimately, color chemistry is a subject of vast interest and the study of the interaction of light and the electronic constituents of matter has long been an area of mathematical assessment.¹

Organic Pigments

Organic pigments are characterized by transparency, variable chemical/physical stability, and their “clean” bright colors. Color is produced by chromophoric groups, generally electron donors such as $-\text{N}=\text{N}-$, $-\text{NO}_2$, $-\text{NO}$, $-\text{C}=\text{O}$, and $-\text{C}=\text{S}$. Shade is modified or intensified by auxochromes, generally electron acceptors such as $-\text{NH}_2$, $-\text{NHR}$, $-\text{NR}_2$, $-\text{OH}$, and OCH_3 . Organic pigments are primarily conjugated cyclic compounds based on a benzene ring structure, although some exist in heterocyclic form. The three main types of these pigments are lakes, toners, and true pigments. In order to maintain color consistency from batch to batch, organic pigments are typically used without diluents or substrates.

A lake is essentially an insoluble colorant produced by precipitating a permitted soluble dye to a permitted substrate. In the cosmetic industry, most lakes are aluminum based, although zirconium lakes can also be found. From a stability standpoint, true aluminum lakes can be affected by extremes of pH, which will ultimately result in the reformation of the soluble dye or “bleeding.” Lakes are fairly transparent and do not particularly light fast.

Toners are colorants made with other approved metals such as barium and calcium besides aluminum. Generally, toners are more resistant to heat, light, and pH, although extremes of pH can result in shade changes.

A true pigment is an insoluble compound that contains no metal ions (e.g., Drug and Cosmetic [D&C] Red #30, D&C Red #36). True pigments are the most stable of the organic pigments listed.

Soluble azo dyes such as Food, Drug, and Cosmetic (FD&C) Yellow #5, FD&C Yellow #6, and D&C Red #33 lakes are often used in lipsticks and nail lacquer. Barium lake of Red #6 and calcium lake of Red #7 are the most popular colors for cosmetics, also used in lipsticks and nail lacquer because of high strength, bright hues, good light fastness, and chemical and heat stability. Colors in this group do not need a substrate to make them insoluble.

Many color organics are not suitable for cosmetics applications because of their chemical nature. D&C Red #36, a typical insoluble azo color, is not recommended for lipstick. Due to its very slight solubility in oils and waxes, this color organic tends to crystallize upon continual reheating of the lipstick mass. Non-azo soluble dyes such as D&C Red #21, D&C Orange #5, and D&C Red #27 are fluoresceins and act as pH indicators and will change accordingly. All mentioned colorants stain the skin, with D&C Red #27 giving the strongest and bluest stain.

Categories of Organic Colorants

azo Colorants: $-N=N-$

- Insoluble (unsulfonated): D&C Red #36, light stable.
- Soluble (sulfonated): D&C Red #33, FD&C Red #40, FD&C Yellow #5, and FD&C Yellow #6. Stable to acid, alkali, and light. Bleeds in water.
- Slightly soluble (sulfonated/insoluble salt): D&C Red #6, D&C Red #7, D&C Red #34. Color shift in acid and alkali. Light fast, and resistant to oil bleed.
- Oil soluble (unsulfonated): D&C Red #17.

Note: On the basis of a Scientific Committee on Cosmetic and Non-Food Products (SCCNFP) opinion, certain European member states have proposed a ban of the azo dyes that could split into aromatic amines classified by the Convention on the Contract for the International Carriage of Goods by Road (CMR) as CMR 1 and 2 by the Dangerous Substance Directive. The SCCNFP has asked the Cosmetic, Toiletry, and Fragrance Association (CTFA) for data to demonstrate that there is an acceptable risk in continuing to use azo dyes in cosmetics. The issue is how the dyes can break down.

Xanthenes

D&C Orange #5, D&C Red, D&C Red #21, D&C Red #27 “staining dyes.” The structure changes with the pH, has poor light stability, and bleeds in solvent.

Triarylmethane

FD&C Blue #1, FD&C Green #3. These materials are water soluble and have poor light stability.

Anthraquinone

D&C Green #5. These materials have good light stability.

Quinoline

D&C Yellow #10, D&C Yellow #11. These materials are oil soluble.

Indigoid

D&C Red #30. These materials have good resistance to chemicals, light, and bleed. One exception is they are acetone soluble.

Stability of Organic Pigments

- *Overall stability:* True pigments > Toners > True lakes.
- *Light stability:* Anthraquinone > Quinine > Indigoid > azo > Triarylmethane > Xanthenes.
- *Heat stability:* True pigments are stable to heat.
 - Toner (D&C Red #7 Ca lake) changes reversibly.
 - Lakes (D&C Red #27 Al lake) changes irreversibly.
- *pH stability:* 4–9.
- *Metal ion stability:* Unstable.
- *Solubility:* True lakes tend to bleed in water. Fluorescein lakes bleed in solvent.

Natural Dyes²

Natural dyes (Table 17.1) are generally used in food and there are no restrictions for use in cosmetics. The resistance of natural dye to heat, light, and pH instability is for the most part inferior to their synthetic counterparts. Another disadvantage is that natural dyes usually suffer from strong odors. In Table 17.1, all natural dyes listed are of vegetable origin with the exception of cochineal, which is an extract from the crushed insect *Coccus cactii*.

Inorganic Pigments^{3–6}

Inorganic colorants (Table 17.2) are formed from compounds of the transition elements. Color is produced based on how easily the outer d shell electrons can absorb visible light and can be promoted to the next higher energy level. In a comparison between organic and inorganic pigments, inorganic pigments

TABLE 17.1

A Summary of Natural Dye Colors, Descriptions, and Sources

Color	Description	Source
Yellow	Curcumim	Turmeric
Yellow	Crocin	Saffron
Orange	Capsanthin	Paprika
Orange	Annatto	Annatto
Orange	Carotenoids	Carrots
Red	Cochineal	<i>Coccus cactii</i>
Red	Betanine	Beetroot
Red	Anthocyanins	Red berries
Green	Chlorophylls	Lucerne grass
Brown	Caramel	Sugars

TABLE 17.2

Inorganic Pigments with Associated Color, Chemical Composition, and Properties

Inorganic Pigment	Color	Chemical Composition	Properties
Iron oxide	Red	Fe_2O_3	Good stability
	Brown		Opacity
	Burgundy		
	Black	Fe_3O_4	
	Yellow	FeOOH	
Ultramarines	Blue	$\text{Na}_x(\text{AlSiO}_3)_y\text{S}_z$	Good light stability
	Violet		Low tinting strength
	Pink		Unstable to acid
Manganese violet	Violet	$\text{NH}_4\text{MnP}_2\text{O}_7$	Good light stability Low tinting strength Unstable to water
Chromium hydroxide	Aqua	$\text{Cr}_2\text{O}_3 \times \text{H}_2\text{O}$	Good stability Low tinting strength
Chromium oxide	Green	Cr_2O_3	Good stability Opacity
Ferric ammonium ferrocyanide	Deep blue	$\text{FeNH}_4\text{Fe}(\text{CN})_6$	Low light stability High tinting strength Unstable to alkali and salts Difficult dispersion
Ferric ferrocyanide	Deep blue	$\text{Fe}[\text{Fe}(\text{CN})_6]_3 \times \text{H}_2\text{O}$	Low light stability High tinting strength Unstable to alkali and salts Difficult dispersion Precipitated on a substrate (i.e., mica)
Hydrate alumina		Al_2O_3	Little opacity; almost transparent
Barium sulfate			Relatively translucent May be used as a pigment extender
Titanium dioxide	White	TiO_2	Medium light stability
		Anatase	Good chemical stability
		Rutile	High opacity

are usually more opaque, light fast, and solvent resistant. However, inorganic colors are not as bright as organic colors, and may be affected by alkali and acid.

Titanium Dioxide (TiO_2)

This material is visually a brilliant white pigment which also has anti-inflammatory properties.⁷ Two crystal types of TiO_2 occur: anatase and rutile. In order to produce these crystals, there are two manufacturing processes that are employed: (1) The sulfate manufacturing process has the ability to produce either type of crystal, while (2) the chloride manufacturing process produces only rutile crystals.

Rutile and anatase crystals are tetragonal. Rutile crystals have greater coverage due to the close packing orientation of the atoms in the crystal. The refractive indices for anatase and rutile crystals are 2.55 and 2.71, respectively. The resultant opacity is due to the light scattering ability of the TiO_2 . Light, heat, and chemical stability are excellent when employing this material. Additionally, in the United States, TiO_2 is regarded as a Category I sunscreen.

Zinc Oxide (ZnO)

Zinc ore is roasted and purified at 1000°C . The two methods of manufacture are (1) French, an indirect method and (2) American, a direct method. ZnO is in the form of transparent hexagonal crystals. The

refractive index of this material is 2.0 with whiteness due to the scattering of light by the ultrafine particles. The coverage on the skin of ZnO is subordinate to that of TiO₂.⁸ This material is soluble in acid and alkali with good heat and light stability. ZnO is used primarily for its anti-bacterial and fungicidal properties. Also, in the United States, ZnO is regarded as a Category I skin protectant and a Category III sunscreen.

TiO₂, ZnO, and Composite Materials in Sunscreens

Typically the inclusion and subsequent performance of multiple parameters ultimately determines the effectiveness of a raw material. In sunscreens, an optimal product likely possesses sufficient Sun Protection Factor (SPF) and critical wavelength values for broad spectrum claims, all while achieving pleasing aesthetics. Typically in formulation two types of sunscreens are used, namely physical sunscreens and chemical sunscreens. Physical sunscreens reflect and scatter UV radiation whereas chemical sunscreens absorb UV radiation. In the market, popular chemical sunscreen ingredients include avobenzene, oxybenzone, octisalate, and octinoxate. Sunscreen materials, whether organic or inorganic, are unique, since the materials can be used as sole active ingredients or in combination with others.

Inorganic physical sunscreen filters are not new to the sunscreen sector and boast attributes such as no skin penetration and non-irritating properties. Inorganic sun blockers are ideal for formulating mild or hypoallergenic sun care products for UVA/UVB protection. Nano-materials have been widely used in sunscreens due to their ability to attenuate UV light and transmit visible light. The motivation for using nano-materials in cosmetics is largely because of this ability to attenuate UV light and transmit visible light or to provide color; for example, a mascara containing carbon black (CB). Recently, concerns including skin penetration and free radical generation from the use of nano-materials have led the European Union (EU) to define these materials and require labeling in the instance of sunscreens. Developing a solution to this nano-particle predicament has varied across the industry. An obvious, instantaneous resolution is to abandon the use of nano-particles all together. However, this approach does not necessarily eliminate a problem, since abandoning nano-products means discarding high-performing raw materials. Alternatives include non-nano TiO₂ and ZnO, and composite materials that offer the perceived benefits of nano-materials but do not use nano-materials in their conventional form are clearly in need.

Not only can sunscreen actives be obtained in powdered form, but availability also exists as powder coated with organic and inorganic surface treatments. Furthermore, dispersion technologies are excellent resources for formulators who should not have to exhaust their time performing an unnecessary function since key manufacturers possess specialized equipment and processes for producing high quality dispersion products. From an aesthetics perspective, when these dispersions are used on the skin there is limited whitening and a pleasant skin feel upon application. These dispersions come in an array of carriers.

TiO₂ and ZnO

Nano

Attenuation grade TiO₂ is typically measured to be less than 100 nm. It is commonplace in UV protection to find surface coated TiO₂ with a primary particle size of 15 nm or 35 nm. Recent developments in this area now provide the ability to generate TiO₂ with a primary particle size of 10 nm. These particles have the ability to be ground finer for higher UVB protection and increased transparency. Attenuation grade ZnO of smaller size will give better transparency, more UVB protection, and generally more UVA protection when ZnO powder is used directly in a formula. Attenuation grade TiO₂ and ZnO that are surface treated are also available for an easier dispersion in a wide variety of carriers.

Non-Nano

It has been the goal of scientists to develop TiO₂ and ZnO products with mean particle sizes over the nano classified level of 100 nm while keeping suitability in cosmetic formulations as far as adequate UV attenuation and aesthetics.

Overexposure of UV sun rays typically results in erythema, a visible marker of skin damage signified by redness of the skin. Wavelengths over a range of 290–320 nm are primarily responsible for erythema in human skin. Exposure to UV light in general enhances the risk of skin cancer development regardless if erythema of the skin is or is not present afterward.⁹ UVA rays comprise the vast majority of rays reaching the Earth's surface year round since they are not blocked by clouds or the ozone layer. UVA penetrates deeper into the skin than UVB, reaching well into the dermis and will cause immediate sun-tan, not sunburn, thus creating the false notion that damage is not occurring since a burn is not present. UVA is also responsible for generating free radicals in living skin, which contribute to skin damage, wrinkling, and skin cancer.

Non-nano TiO₂ is commercially available, with particle sizes greater than 100 nm (commonly measured by light scattering sizing). These products have been designed to help formulators develop sunscreen products with high SPF/protection factor in UVA (PFA) and transparency without nanoparticles. Non-nano ZnO is a dynamic material with the ability to inhibit UV exposure, thus providing an avenue to formulating effective sunscreen products. ZnO has shown considerable effects on the attenuation of UVA (320–400 nm) and UVB (290–320 nm), one of the few if not the only single active ingredient able to achieve broad spectrum coverage on its own. These non-nano TiO₂ and ZnO powders are available on the market coated with inorganic and organic surface treatments, and dispersed in various vehicles for easier use in formulating sunscreens.

Composite Series (TiO₂, ZnO, CB)*

Another alternative to nano sized inorganic UV blockers is the use of a novel composite structure technology that offers a new avenue for formulation. This unique and innovative approach relies on the concept of a matrix that consists of a polymeric material and a nano-material. The core foundation of this technology is to initiate the process with a dispersion having already decreased the aggregate size. The aggregates are continuously controlled and maintained against re-agglomeration throughout the process resulting in enhanced efficacy of this material. This is a multiple functionality innovation since the spherical outer matrix of the composite allows for a micron size powder to be generated while providing mechanical resistance during use and enhanced tactile properties in application.

The manufacturing technique used to generate this composite allows for dispersed nano-particles to be encapsulated into an acrylate copolymer matrix with the resultant material being of the order of the micron size level. The guidelines for these non-nano composite powders are to provide acceptable and also optimum levels of efficacy, color intensity, and minimal whitening in cosmetic formulation. The matrix is engineered to limit re-agglomeration of the aggregates to achieve the desirable cosmetic effect. From a sensory perspective, the micron sized composite materials offer superior tactile properties.

Currently three different composites in this particular series exist with the primary difference being the pigment that the acrylate copolymer is comprised of (TiO₂, ZnO, or CB). The composite encapsulating TiO₂ and the composite encapsulating ZnO find applicability in sunscreens whereas the composite encapsulating CB is used in mascara formulation as a two-in-one benefit to create volumizing effects with high payoff.

This composite technology is of exceptional value to the advancement of cosmetic material science and technology. Furthermore, there is the potential to incorporate other ingredients based from the same conceptual idea, which shows the boundless opportunity to form derivative products. As industry looks towards solutions for the dilemma of nano-sized raw materials, it is clear that forward thinking has paved the way for new materials such as those presented in this section.

* www.koboproduct.com.

Iron Oxides

Iron oxides are used in an array of cosmetic products. The inherent colors (black, red, and yellow) have the ability to be blended in varying ratios to create a broader range of colors including brown, tans, umbers, and sienna.

Black iron oxide (Fe_2O_4) is a mixture of ferrous and ferric oxide. It is prepared by controlled oxidation of ferrous sulfate under alkaline conditions. Red iron oxide (Fe_2O_3) is obtained by the controlled heating (at about 1000°C) of yellow iron oxide. Yellow iron oxide is hydrated iron II (ferrous) oxide ($\text{Fe}_2\text{O}_3 \times \text{H}_2\text{O}$). It is produced by the controlled oxidation of ferrous sulfate.

Ultramarines

Chemically, ultramarines are polysulfide sodium/aluminum sulfo-silicates. These mixtures are calcined at $800\text{--}900^\circ\text{C}$ for 4–5 days. The colors of these materials are in a range from blue to violet, pink, and even green. Shades are dependent on reaction time, formula variations, and particle size. Ultramarine violets and pinks are obtained by treating ultramarine blue with HCl at 275°C to remove portions of sodium and sulfur from the molecule.

Manganese Violet

Manganese violet ($\text{MnNH}_4\text{P}_2\text{O}_7$) is manufactured by heating manganese dioxide with ammonium dihydrogen phosphate and water. Phosphorous acid is added and the mixture is heated until the violet color is developed.

Iron Blue

Iron blue is chemically referred to as ferric ammonium ferrocyanide $\text{Fe}(\text{Fe}(\text{CN})_6)_3$. This material is generated through the reaction of sodium ferrocyanide and ferrous sulfate in the presence of ammonium sulfate. Pigments prepared with sodium or potassium salts are called ferric ferrocyanide.

Chromium Oxide

Chromium oxide (Cr_2O_3) is a dull yellowish-green pigment that may be prepared by blending an alkali dichromate with sulfur or with a carbonaceous material. Reduction to chrome (III) oxide is achieved in a kiln at 1000°C .

Chromium Hydroxide

Chromium hydroxide ($\text{Cr}_2\text{O}(\text{OH})_4$) is a bright bluish-green pigment prepared by the calcinations of bichromate with boric acid at 500°C . The mass during cooling is hydrolyzed with water, which yields the hydrate.

Pearlescent Pigments and Other Specialty Pigments

Pearlescent Pigments

Pearlescent pigments are unique additives to provide formulations with exceptional intensity, brilliance, and luster. Ideal application for such pigments is in color cosmetics including foundations, face powder, lipsticks, eye shadows, and nail care. Other applicable areas are in plastics, industrial coatings, printing inks, and automotive paints.

Pearlescent pigments are plate-like substrates with a high refractive index. Synthetic pearlescent pigments are transparent or light absorbing crystal structures. This structure can be monocrystalline or

multi-layered where the material consists of alternating materials with differing refractive indices and light absorption properties.¹ Because of the smooth, flat, thin, and transparent orientation, light is easily transmitted, allowing for specular reflection. As a general guideline, these types of pigments work best in transparent formulations and can be employed as a combination of color components to generate unique color effects. It is important to avoid grinding or milling of these pearlescent pigments to retain the integrity of its structure and subsequent color. Furthermore, the formulator must pay close attention to make sure the pigments are non-toxic and meet all heavy metal safety requirements.

Organic Pearls

Since ancient times, pearls and nacreous shells have been used for beautifying purposes. Attributed to the “pearl effect” are crystals of a purine called guanine. Guanine yields a pearly iridescent effect and can find cosmetic applicability in shampoo, eye shadow, and nail enamel. Organic pearls appear as a bright silver effect typically obtainable from sources like the scales of some fish in the form of platelets or needles. These forms are highly reflective and essential to producing this unique effect pigment.¹⁰

Inorganic Pearls

In order to capture the effects that can be found in nature, a variety of cations were produced for this purpose, starting in the second decade of the 1900s.

Inorganic pearlescent pigments are available in an array of colors, substrates, and matrix structures. Substrate examples include mica, synthetic fluorophlogopite, and borosilicate. Mica based pearlescent pigments are predominant on the market, accounting for >90%.¹ The coating material, thickness of the coating, and degree of coating layers all play a key role in the ultimate color. For instance, a particular substrate coated with TiO_2 will produce a material different from a substrate coated with iron oxides. “Color travel” effects are seen when changing the viewing angle. This effect is attributed to a dual interference reflection matrix achieved by a unique composite comprised of a substrate coated by layers of varying materials with varying thicknesses. This technology provides vivid effect pigments possessing intense saturation of color. In addition to the options available from different substrates, coatings, and matrix, hydrophobic surface treatments can be applied to these pearlescent pigments to enhance flow, dispersion, wear, and appearance.

Bismuth Oxychloride (BioCl)

This material is synthesized as tetragonal crystals and produces a silvery grey pearlescent effect. The crystal size of BioCl varies over a range of approximately 8–20 μm . The lower end of the size range results in a soft, opaque, smooth luster while the upper end of the size range will give a more brilliant sparkle effect. A drawback of using this ingredient in formulation is its poor light stability, which has the possibility of causing darkening over prolonged exposure. However, incorporating UV absorbers in the formulation will aid in overcoming this defect. Applicability is found in nail enamels, lipsticks, blushers, and eye shadows. Modification of BioCl can be made by depositing the material on mica, TiO_2 , or talc.

TiO₂ Coated Mica

As mentioned previously, TiO_2 coated mica is widely used in color cosmetic applications. There are variations in which this matrix of materials exists. One such form is uniformly coating platelets of mica with silver TiO_2 . Rutile crystals supersede the effect of anatase grade in that they give a brilliant pearl effect due to a high refractive index. Another form is interference pearlescent products, which are made by altering the thickness of the coating film. The concept behind this type of product is that at certain thicknesses, some wavelengths of incident light are reflected while others are transmitted. The reflection colors progress from silvery white, to yellow-gold, to red, to blue and then green. An introduction of iron oxides to this matrix will produce a two-color effect.

Specialties

Other pigment systems include polyester foil cut into regular shapes that are epoxy coated with light fast pigments for use in nail enamels and body makeup. Also, aluminum and copper/bronze powder have been used in eyeshadows. In order for the latter to be used in cosmetic applications, 100% aluminum powder is expected to pass through a 200 mesh screen and 95% of the same powder particles are expected to pass through a 325 mesh screen.

Treated Pigments¹¹⁻¹⁶

Typically a pigment has a hydrophilic surface where polar hydroxyl groups and absorbed moisture can be found. Pigment particles commonly agglomerate and exhibit poor skin feel as well as a multitude of other problems including poor wettability and dispersibility in cosmetic grade media, poor dispersion and formulation stability, poor chemical stability of metal oxides, and pressability in pressed powders. With this said, surface modification is an essential tool in enhancing the performance of pigments while also tailoring the pigment properties to individual needs (Table 17.3).

Colors and substrates altered with organic and inorganic surface treatments are a valuable tool to chemists. Surface treatments provide the ability to tailor the properties of a substrate, namely esthetics and functional qualities in order to optimally incorporate the ingredient into formulation. The treatments are designed to enhance the surface of the material through the alteration of the chemical and physical properties. Overall performance is dependent on the physical and chemical properties of the treatment, integrity of the bonding between the treatment and substrate, the degree of coverage the coating provides, and the potential of the substrate for surface treatment due to available reaction sites. The potential for individual surfaces to react with a surface treatment will vary based on the substrate material. For example, materials that exhibit hydroxyl groups such as silicates, hydroxides, and inorganic metal oxides have a higher surface treatment potential than a material which lacks these qualities such as CB. The bond strength with the particle substrate can achieve enhanced mechanical properties, reduced shrinkage, increased stability, and lessening of surface defects. Treated substrates result in enhanced dispersion, powder flow characteristics and flow during mixing. In addition, treatments allow for higher filler loading with the loading level on the filler surface dependent on the surface area of the filler.

The properties obtained by implementing surface treatments provide variations like hydrophobicity, hydrophilicity, and lipophilicity with the selection of a treatment dependent on the desired properties to be exhibited by the treated substrate. The chemistry of the surface treatments differ over a broad range including those that are Ecocert approved.

Microfine Pigments

Microfine, ultrafine, and nano-sized pigments have a primary particle size below 100 nm; however, larger agglomerates of the fine particles can also be present. Properties such as surface area, bulk density, vehicle absorption, and UV absorption differ significantly in these materials in comparison to a conventional pigment.

Microfine TiO₂, ZnO, and iron oxides can be utilized in a range of color cosmetics to provide unique visual effects as well as UV protection. With these types of materials, significant SPF values can be achieved while simultaneously having a translucent, natural looking finish in products like pressed powders, anhydrous, and emulsified systems. Formulations for darker skin tones can be formulated using microfine pigments to avoid “ashy” or “made-up” appearance, which can occur by using conventional opaque pigments.

Light Diffusing Pigments

Some of the requirements for light diffusing pigments include a high refractive index, ability to diffuse reflection/translucency, and the pigment's transmission must be primarily diffuse. Examples of light diffusers include: BaSO₄, SiO₂, SiO₂ spheres coated on mica, TiO₂/BaSO₄ coated mica, AL₂OH/mica, ultrafine TiO₂/mica, ultrafine TiO₂/polyethylene, ethylene acrylates copolymer, and polymethyl methacrylate (PMMA). These products are primarily used in powders to create illusions and to obscure fine lines/hidden wrinkles on the skin (refractive index 1.60).

TABLE 17.3

Selected Surface Treatments and Their Attributes

Treatment Category	Details	Selected Properties
Aloe	Natural origin	<ul style="list-style-type: none"> • Creamy feel • Improves adhesion to the skin • Improves pressability and spreadability
Amino acids	N-lauroyl lysine, acyl amino acid ³³	<ul style="list-style-type: none"> • Natural • Good skin adhesion • pH balanced • Heat sensitive
Carnauba wax	Natural origin	<ul style="list-style-type: none"> • Hydrophobic • Creamy feel • Good adhesion to the skin • Improves pressibility in powders
Dimethicone		<ul style="list-style-type: none"> • Good slip and lubricity over methicone treatment • No hydrogen potential • Hydrophobic (less than methicone) • Good for wet/dry powders and W/Si emulsions
Fluorochemical	Perfluoropolymethylisopropyl ether perfluoroalkyl phosphate	<ul style="list-style-type: none"> • Hydrophobic and lipophilic • Enhanced wear • Heat and shear resistant
Hybrid surface treatment (silane and polyhydroxystearic acid)		<ul style="list-style-type: none"> • Hydrophobic • Lipophilic
Hydrogenated lecithin	Natural origin A natural phospholipid with anti-oxidant, moisturizing, and emollient properties	<ul style="list-style-type: none"> • Hydrophobic yet moisturizing • Creamy feel and affinity to the skin • Good for powders, mineral makeups, emulsions, and hot pours
Hybrid (Isopropyl triisostearyl titanate and dimethicone)	Crosspolymer formed at the surface of the pigment	<ul style="list-style-type: none"> • “Super dispersible” in esters, silicones, and hydrocarbons • Hydrophobic • Stable over a range of pH • Better affinity to skin than common silicone coatings
Jjoba ester	Natural origin and Ecocert certified	<ul style="list-style-type: none"> • Hydrophobic • High oxidative stability • Does not turn rancid with heat • Creamy feel • Good skin affinity • Good pressability in powders • Successful in hot pours and emulsions
Lecithin ³⁴		<ul style="list-style-type: none"> • Natural • Exceptional smooth and silky skin feel particularly in pressed powders • Heat sensitive • Slightly soluble in water
Magnesium myristate		<ul style="list-style-type: none"> • Hydrophobic and lipophobic • Creamy feel • Increased adhesion to the skin • Improved wear • Better pressability

(Continued)

TABLE 17.3 (Continued)

Selected Surface Treatments and Their Attributes

Treatment Category	Details	Selected Properties
Metal soaps	Zinc, magnesium, stearate	<ul style="list-style-type: none"> • Good skin adhesion • Enhanced compressibility
Methicone	Crosslinked coating layer	<ul style="list-style-type: none"> • Very hydrophobic • Stable at pH 3–9 • Skin feel is somewhat dry • Good for wet/dry powder and W/Si emulsions • Not very compatible with esters, oil, and oil/water emulsions
Natural wax (general)		<ul style="list-style-type: none"> • Natural • Moisturizing skin feel • Good skin adhesion • Heat sensitive; low melting point
Nylon	Pure mechanically coated	<ul style="list-style-type: none"> • Smooth skin feel
Perfluorooctyl triethoxysilane		<ul style="list-style-type: none"> • Hydrophobic and lipophobic • Resilient to sebum; long wear
Polyacrylate		<ul style="list-style-type: none"> • Enhances wetting in aqueous systems • Feeling is not optimal but typically used in dispersion
Polyethylene		<ul style="list-style-type: none"> • Hydrophobic • Waxy, smooth skin feel • Enhanced compressibility • Heat sensitive
Silane (triethoxycaprylsilane)		<ul style="list-style-type: none"> • Easily dispersed in esters, mineral oils, and silicone fluids • Higher pigment loading than methicone treatments • Stable at pH of 3 • Extremely hydrophobic and lipophilic • No hydrogen potential • No residual methanol • Nice spreadability, creamy, wet feeling
Silicone	Polymethylhydrogensiloxane; methicone will be chemically bonded and cannot be removed later	<ul style="list-style-type: none"> • Hydrophobic • Achieves full color development • Mainly used to improve wetting
Titanate ester ¹¹	Isopropyl triisostearyl titanate	<ul style="list-style-type: none"> • Lipophilic; easily dispersed in esters, mineral oils, or hydrocarbons • Excellent affinity to the skin • Smooth skin feel • Enhances wetting in oil • High pigment loading • Lowers oil absorption of pigments • Not stable in acid
Other silicones (no potential for hydrogen evolution)	Dimethiconol, absorbed dimethicone, silicone/lecithin	

Color Pigment Complexes

In the cosmetic industry, deviations of popular products are constantly being created in order to stay in tune with new demands. With this said, a progression towards raw materials with multiple benefits has come into the spotlight. Pigment complexes are among the new innovations to combine multiple functionalities conveniently into one material. Encapsulating pigments in an outer spherical matrix is a new approach for formulations such as mascara and eyeliner. The concept uses pre-dispersed nano-particles such as CB and encapsulates the particles in a micron sized acrylate copolymer. The overall attributes of such a material includes non-nano claims, mechanical resistance during use, enhanced tactile properties, imparts color, creates volume, gives good payoff.

Makeup Technology

Color cosmetics are a large sector in the personal care market and encompass many different areas including liquid foundation, powder (pressed and loose) foundation, BB cream, concealers, blushers, mascara, eyeliner, eye shadow, lipstick/lipgloss color, nail color, sunscreen, and combination products. The purposes of these products are chiefly to impart color but also to improve appearance, even out skin tones, hide imperfections, and protect the skin. Formulations themselves can exist in various phases of emulsions, such as oil-in-water or water-in-oil, while also vary as suspensions, aqueous, or anhydrous systems.

Powder Cosmetics

A powder cosmetic is a generic term addressing a variety of sectors including face powders, blushers, and eye shadows. Ideally, when the product is applied to the skin, it must be easy to apply/smooth, the shade cannot suffer from color shift, and it must adhere well for a reasonable time without the need for reapplication.

Face Powders

There is a wide range of raw materials used in powdered cosmetics and similarly many of these same raw materials transcend into the formulations of other color cosmetics. Typically, in satisfactory face powders, attributes include: (1) gives smoothness to overall texture, (2) gives added skin translucency when excess is buffed, (3) makes the skin appear more refined with less texture, (4) helps set the makeup base and adds longevity to the makeup overall, and (5) suppresses oil and shine.

Loose Face Powders

Loose powders have declined in popularity compared to pressed powders, although these types of products still have a large presence on the market. Recent developments have shown renewed interest in loose powder, with popularity and much success found in makeup kits providing customers with loose mineral powder systems.

In the manufacturing process, all ingredients with the exception of pearls (if in the formulation), are combined in a stainless steel ribbon blender with a mixing time of up to 1 or 2 hours depending on the size of the batch and evenness of the color. If using perfume, it is slowly sprayed into the batch until homogeneous. The batch is pulverized through a hammer mill and then the color is checked. If necessary, color adjustments are made in the ribbon blender and re-pulverized. Any pearl or mica is added and put through a final mix. The batch is then stored, ready for filling into containers.

Pressed Face Powders

Pressed powders have gained popularity due to their ease of portability and, in some ways, application. The basic outline of raw materials are similar to that of loose powders with the exception of the need for

a binder to press the cake into a tin-plate godet. Aluminum godets are usually used to prevent corrosion if the formula uses a water-based binder.

Binders provide creaminess to the powder, aid in compression and adhesion, develop colorants, and enhance water resistance, pick-up, and deposit. If the binder level is too high, it may be difficult to remove the powder from the component since the powder surface can glaze, making it look waxy with little or no payoff. Examples of binder systems are fatty soaps, kaolin, polyethylene, Teflon®, synthetic wax, and calcium silicate, with usage levels between 3% and 10%.

Silicone treated pigments provide the ability for pressed powders to be used wet or dry. When used dry, these formulations are usually smoother than regular pressed powders. When a wet sponge is applied to the cake, no water penetrates. These “two-way” cakes can be used either as foundation or face powders.

In manufacture, the mixing and color matching process is similar to loose powders. Sometimes the powder mix is pulverized without binder and then again after its addition. Pearls are usually added during the blending process and preferably without the milling operation to prevent damage to the pearls. If it is necessary to mill a batch with pearls, the mill screen should be removed.

Powder pressing is often more successful if the powder is kept for a few days to allow for the binder system to spread. The pressure and speed of pressing is dependent on the formulation and size of the godet. Common presses for face powders include: ALITE-high speed hydraulic press and the KEM WALL, CAVALLA or VE. TRA. Co.

Face Powder Ingredients³⁵

The following sub-sections address common raw materials found in face powders, with a brief summary of each material. The materials provide a variety of attributes to formulations including enhanced texture, oil control, and delivery, among others.

Talc

Talc, a hydrated magnesium sulfate, is the primary component of most face powders (eye shadows and blushers). In some products, talc makes up to 70% of the formulation. Cosmetic talc should be white, free of asbestos, should have high spreadability or slip, with low coverage. Particle size is acceptable if the material passes through a 200 mesh sieve. Micronized talc is generally lighter and fluffier but less smooth on the skin than regular grades. Typically talc products are sterilized using gamma irradiation. Cosmetic talcs are mined in Italy, France, Norway, India, Spain, China, Egypt, Japan, and the United States. Talc is fairly hydrophobic, although treatments are used to enhance its texture.

Kaolin

Kaolin or china clay is a naturally occurring, almost white, hydrated aluminum silicate. This material does not exhibit a high degree of slip. Kaolin boasts good absorbency, is dense, and is sometimes used to reduce the bulk densities in loose powder products. It provides a matte surface effect, which can slightly reduce sheen left by some talc products.

Calcium Carbonate

Calcium carbonate or precipitated chalk has excellent absorption properties. It provides a matte finish and moderate coverage. High levels of this material will cause an undesirable, dry, powdery feel and should be avoided.

Magnesium Carbonate

This material is available in a very light, fluffy grade which absorbs well. The before-mentioned qualities are why magnesium carbonate is often used to absorb perfume before incorporation into face powders.

Metallic Soap

Zinc and magnesium stearate are important materials for imparting adhesion to face powders. These materials are usually incorporated at a level of 3%–10%. Stearates impart water repellency to formulas, but elevated levels cause a blotchy effect on the skin. Zinc stearate has the added benefit of providing a smoothing quality to face powders. Aluminum and lithium stearates have also been employed in powder formulations, although too high of levels will make a pressed formulation too hard.

Starch

Starch is used in face powders to give a “peach-like” bloom and also to provide a smooth surface on the skin. One problem with rice starch is that when it is moistened, it tends to cake. Furthermore, another drawback is that the wet product might provide an environment for bacterial growth.

Mica

Cosmetic mica, potassium aluminum silicate dehydrate, is refined and ground to particles of $\leq 150 \mu\text{m}$. This material imparts a natural translucence when used up to 20% in formulations of face powder blushes. Mica is available as wet ground (creamy) or as dry ground (matte).

Sericite

Sericite is a mineral similar to white mica in shape and composition. It has a very fine grain size and a silky shine. This material is soft and smooth and has a slippery feel on the skin. Sericite may be coated with silicone and other treatments for enhanced water repellency and skin adhesion.

Polymers

Polymers are essentially used for texture enhancement at usage levels ranging from 3% to 40% dependent on the type of formulation. Many polymers are treated with silicones, titanates, and lecithin (among others) to increase their effectiveness.

- Nylon 6, Nylon 12, lauroyl lysine, and boron nitride assist the active ingredients to spread more uniformly on inactive bases.
- Polyethylene (PE), polypropylene (PP), and ethylene acrylates copolymer are very sheer and will not affect the binder in pressed powders. Their processing temperatures are $< 85\text{--}90^\circ\text{C}$.
- PMMA and silica beads can carry oily ingredients into a system and increase wear on oily skin.
- Polyurethane powders, silicone powders, borosilicate, microcrystalline cellulose, acrylates copolymers, Teflon, and Teflon composites are effective at low concentrations (1%–5%).
- Polyvinylidene copolymers are very light with ultra low density.
- Composite powders are coated on inexpensive beads to reduce costs and increase effectiveness (e.g., Nylon/mica, silica/mica, lauryl lysine/mica, and boron nitride/mica).

Colorants

Colorants found in cosmetics include pigmentary and ultrafine TiO_2 and ZnO , organics, inorganics, carmine, and pearlescent pigments. These materials are most likely pre-dispersed or treated since the inherent textures of these colorants are not satisfactory for face powders.

Perfumes

The use of perfumes is an important component of face powder since most of the raw materials in the formulation exhibit an earthy smell which needs to be masked. Ideally, perfumes should show stability and volatility.

Preservatives

Preservation of face powders is typically not an issue since these products are used dry; however, small amounts of anti-bacterials are recommended. Specifically, powdered eye shadows should always contain anti-bacterials, for example parabens, and imidazolidinyl urea.

Powder Blushers

Blushers are used to add color to the face, to give dimension to cheekbones, to harmonize the face balance between eye makeup and lipstick, and to create subtle changes in the foundation look. The difference between pressed powder blushers and face powder is that a greater range of color pigments are used in formulation. Raw materials to create blusher shades include the three basic iron oxides, and one or more of the lakes. Total pigment concentration ranges from 2% to 10% excluding pearls. Pressed powder rouges contain high levels of colorants ranging from 10% to 30%.

Manufacture and pressing of these products are similar to that of face powders. To avoid skin staining, only non-bleeding pigments should be used in blusher formulations.

Pressed Powder Eye Shadows

Eye shadows are used to add color and personality to the face, to sharpen or soften the look of the eye, to create an illusion of depth or bring out deep set eyes, and to create light or dark illusions for subtle character changes. Eye shadows can be used wet or dry depending on the intensity of color being sought.

The technology is similar to other pressed powder product; however, the color range permitted is limited. In the United States the only synthetic organic pigments that can be used in eye products are FD&C Red #40, FD&C Blue #1, FD&C Yellow #5, and FD&C Green #5. Carmine N.F. is the only natural organic pigment allowed. All of the inorganic pigments and a variety of pearls are also permitted. Preservation is essential in eye makeup products. Selecting a proper binder for the type/level of pearls in a formulation is essential in preventing poor adherence on the skin, color matching problems, and creasing in the eyelid. Furthermore, a high level of binder can pose problems in the evenness of the product pressed in the godets. During manufacture, formulas with high pearl content should be allowed to settle, with the aim of removing air before pressing.

Quality Assurance of Powder Products

Color

Production batch and standard are placed side by side on a white paper and pressed flat with a palette-knife. Shades are compared with one another. Shades of eye shadow and blushers are checked on skin using a brush or a wand.

Penetration and Drop Tests

These tests are carried out on pressed godets. A penetrometer is used to determine the accuracy of the pressure used during filling. A drop test is designed to test the physical strength of the cake. The godet is typically dropped 1–3 times on a wooden floor or rubber mat at a height of 2–3 feet. The damage to the cake is then assessed.

Glazing and Payoff

The pressed cake is rubbed through to the base of the godet with a puff and any signs of glazing are noted. Payoff must be sufficient and the powder should spread evenly without losing adhesion to the skin.

Foundation

Foundations have several functions such as hiding skin flaws, evening out skin tone, making the skin surface appear smoother, and acting as a skin protectant from the environment. An ideal foundation formulation should be moderately fast drying while also allowing enough “play-time” for even application, should be non-settling, pour easily, provide slip, be stable in storage, feel not too tacky, greasy, or dry, and should improve appearance, with a natural look. Products should be uniform and shade consistency between bottle and skin tone is of top importance. Wear is also essential; the product should not peel off, turn orange on the skin, or rub off on clothes. Formulations often contain treated pigments or volatile silicones to add water resistant properties to the product. With all of this said, skin type also is a variable in how a formulation will look when applied. Finish on the skin may be matte, shiny, or dewy when using the same formula on different people. Foundation makeup exist as emulsions and anhydrous or suspension systems.

Emulsified Foundations

Emulsified foundation compositions can vary depending on the degree of coverage and emolliency desired. When formulating, consideration needs to be made to minimize the level of emulsifier to avoid irritation (choose oils on the basis of low comedogenicity) and also care needs to be taken when preserving a system such as those containing water and gums. Most emulsified foundations are anionic oil-in-water systems due to the ease of generating these products. Anionic systems boast emulsion stability, pigment wetting and dispersion, easy spreading and blending, good skin feel, and a slippery feeling. Non-ionic emulsions exist but are usually not stable. Cationic emulsions are difficult to make and are not on the market. Water-in-oil systems have become popular for water resistance. Water-in-oil systems include volatile silicones, hydrocarbons, mineral oil, and light esters.

The coloration of the emulsion base can be handled in different ways: direct pigment, pigment dispersions, mixed pigment blender, and monochromatic color solutions.¹⁷ Each has its own advantages and drawbacks. In the *direct method*, the pigments are weighed directly into the aqueous phase and dispersed or colloid milled then the emulsion is formed in the usual manner. The major problem is that there are too many color adjustments needed and accurate color matching is difficult. In the *pigment dispersion method*, the pigment is mixed with talc as a 50:50 and pulverized to match a standard. This reduces the number of color corrections needed, but the time taken to make the dispersions and subsequent storage can pose problems. In the *mixed pigment blender method*, the pigments and extenders are premixed, pulverized, and matched to a standard. They are then dispersed in the aqueous phase of the emulsion and the emulsion is formed in the normal way. The finished shade is color matched at the powder blender stage. In this case, chances of error are reduced. The last method, *the monochromatic color solutions*, required one to make color concentrates of each pigment in a finished formula. It is easy to color match by blending finished base, but much storage space is needed and the possibility for contamination is thus increased.

Anhydrous Foundations

These types of formulations (Table 17.4) are powdery and not fluid. They are easy for travel, which has made these types of products popular in recent years.

TABLE 17.4
Basic Formulation Guidelines of Anhydrous Foundations

Basic Formulation (%)	
Emollients (fluids, low melting point waxes, gel-like raws)	30–60
Texturizing agents	30–60
Waxes	5–10
Wetting agents	0.50–1.00

Source: Adapted from GE Silicones. *Personal Care Formulary*. Waterford, NY: GE Silicones, 1996, 149, 151.

Emollients are often texturally light and have low viscosity. Examples include oils, esters, and silicones. *Texturizing agents* are often treated and include nylon, PMMA, sericite, mica, borosilicates copolymer, spherical silica, starches, BioCl, and microcrystalline cellulose, among many others. *Waxes* include natural beeswax derivatives, synthetic fatty alcohols, fatty alcohol ethoxylates, and fatty esters. *Wetting agents* are typically used in a small quantity. These include low hydrophilic-lipophilic balance (HLB) emulsifiers and polyglyceryl esters. *Pigments* are often surface treated and include (pigmentary and ultrafine) TiO₂ and ZnO as well as iron oxides. Bioactives found in foundations include algae extract (anti-inflammatory), hydrolyzed wheat protein (moisturizer and skin protectant), calcium pantothenate (anti-oxidant), and bisabolol (anti-phlogistic), as well as vitamins, just to name a few. Raw materials are frequently surface treated in order to facilitate improved dispersibility, to enhance solids loading, to provide a drier texture, to create a matte appearance, to improve wear, and to improve overall aesthetics.

Regarding manufacturing, these types of formulations can be made in a two-part process. First, emollients, waxes, and wetting agent(s) are introduced into a jacketed kettle and heated until the phase is clear and uniform. Then pigments and texturizing agents are slowly introduced into the oil phase with high shear mixing. High shear mixing is continued until the dispersion is uniform and colorants are completely extended. Care must be taken with temperature sensitive surface treatments in order to prevent the displacement of the treatment from the surface of the raw material into the oil phase itself.

Eye Makeup^{37,41}

Mascara

Mascara serves several purposes, namely (1) brings out the contrast between the iris and the white of the eye and sharpens the white of the eye, (2) thickens the appearance of the lashes, (3) lengthens the appearance of the eye, (4) adds depth and character to the overall look, and (5) sharpens the color of eye shadow. Performance of mascara products is typically evaluated by application, appearance, wear, and ease of removal. Furthermore, the brush which is used in combination with the formulation has substantial impact on the product. Generally mascara is comprised of one or more film formers, pigments, and the vehicle. The vehicle will mostly evaporate, which is part of the process in letting the film set.

Three types of formulations are in current use. *Anhydrous solvent-based suspensions* are waterproof but not smudge proof and difficult to remove. *Water-in-oil emulsions* are also waterproof but not smudge proof and can be removed with soap and water. *Oil-in-water emulsions* are water-based. If the film of an oil-in-water emulsion is sufficiently flexible, it can also be flake proof and smudge proof. Water resistance is achieved with the addition of emulsion polymers such as acrylics, polyvinyl acetates, or polyurethanes.

Solvent Based

These types of formulations consist of hard, high melting point wax, wetting agent, pigment, suspending agent, volatile solvent, plasticizer, and preservative.

Water-in-Oil

The water phase of these types of formulations consists of high melting point wax, lipophilic emulsifier, pigment, preservative, and petroleum solvent. The wax phase of this type of formulation consists of hydrophilic emulsifier and preservative.

Oil-in-Water Emulsions

The water phase of this type of formulation contains water, suspending agent, film former/dispersing agent, pigment, and hydrophilic emulsifier. The wax phase contains high melting point waxes and consists of the components lipophilic emulsifier, plasticizer, and preservative. The manufacturing procedure

TABLE 17.5

Basic Formulation Guidelines
for Anhydrous Mascaras

Basic Formulation (%)	
Solvents	40–60
Waxes	10–20
Resins	3–10
Gellant	3–7
Colorants	5–15
Filler	2–10

follows the general procedure for oil-in-water emulsification except that iron oxides are first wetted and milled in the water phase prior to the emulsification. The final product also goes through a colloid mill, roller mill, or homogenizer.

Anhydrous Mascara

Components of this type of formulation are solvent, wax, resin, gellant, colorant (most often utilizes iron oxide without any surface treatment), and functional filler (Table 17.5). The purposes of these raw materials are to provide body to a film for enhanced thickening properties, and improve transfer resistance and deposit on lashes.

The manufacturing procedure can be done in a two stage process. First, heat waxes, solvents, and resins in a jacketed kettle until the mixture is uniform and clear. Slowly add pigments under high shear and mill until the dispersion is uniform. Then, under high shear conditions add the gellant and mill until uniform. Activate the gellant with a polar additive like propylene carbonate. Add the fillers and mill until uniform. Finally, cool to desired temperature.

Mascara Componentry

The mascara bottle itself is comprised of polymeric materials. For solvent-based formulations, polyvinyl chloride (PVC) is common and for water-based type formulations materials such as high density polyethylene (HDPE), PP are used.

The applicator is usually complex and works as a marketing attraction for users as much as the mascara itself. The brush material, brush shape, fiber diameter, fiber shape, fiber length, wire diameter, and the number of application strokes all play a crucial role in mascara performance. For a thickening mascara a large diameter (rod, wiper, and brush) with significant space between the bristles is used. Conversely, for a defining mascara a smaller diameter (rod, wiper, and brush) with minimal spacing between the bristles is used. Applicators have become even more complex in recent years as demand for a combination of benefits imparted by a product has increased. Now on the market are vibrating, ball shape with spikes, curved wands and more can be seen in packaged products. To highlight the applicator itself, some packages keep the brush outside of the mascara tube so the buyer can visually see it before purchase.

Cream Eye Shadows

Cream eye shadows are a variation to the commonly seen pressed eye shadow. In this type of formulation, care must be taken to avoid creasing and other wear problems. Formulations of this type are typically comprised of volatile solvent, wax, emollient, gellant, colorant/pearls, fillers, and sometimes functional fillers (microspheres, oil absorbents, etc.) (Table 17.6). It is important to maintain a balance of absorption type fillers to maintain similar textures throughout the shade range. As mentioned previously, enhanced textural properties, higher solids loading, improved application and coverage can be achieved with the

TABLE 17.6

Basic Formulation Guidelines for Cream Eyeshadows

Basic Formulation (%)	
Solvents	35–55
Fillers	10–20
Colorants/pearls	5–20
Waxes	7–12
Emollients	3–8
Functional Fillers	5–15
Gellants	1.50–3.50

assistance of using surface treated raw materials that are treated with temperature and solvent insensitive materials. The manufacturing process used is analogous to the outlined process for anhydrous mascaras.

Eyeliners

Eyeliners serve the purpose of framing the eye while adding shape or altering the appeared shape of the eye. These types of products can give the illusion of a larger or smaller eye, and bring out the color contrast between the iris and the white of the eye. Furthermore, eyeliners can give the appearance of thicker eyelashes. Liquid eyeliners have gained increasing popularity and will be discussed in this section. The components to eyeliner formulations include solvent, gellant, wetting agents, polyols, colorants (primarily iron oxides and other inorganics are used), alcohol, and film formers (Table 17.7).

Manufacturing of these formulations first call for the gellants to be premixed with the polyol and added to a heated water phase, which also contains the wetting agent. They are then dispersed under high shear until uniform. Then the colorants are added and dispersed until uniform. The materials are cooled and then alcohol and film former are added at low shear.

Pencils (Eyeliner, Lip Liner, Eye Shadow, Lipstick, Brow, Blush, and Concealer)

Pencils are a very versatile product. Initially pencils were used to provide coloring to the eyebrows and eyelids but have now extended into the uses as lipstick, lip liner, and blushers. Of course the application depends on the hardness of the pencil and the color of the composition. During the evaluation process, pencils are assessed for their shade, texture, penetration, sharpenability, wear, application, and stability. Stability consists of two methods; freeze/thaw and also at 40–45°C. Extruded pencils are typically less stable than molded pencils. Molded pencils will set up within a few days where extruded pencils tend to take a few weeks.

The raw materials that comprise these types of formulations include oils, esters, and silicones. Also included are high melting point triglycerides, stearic acid (aids in extrusion), synthetic waxes, Japan wax,

TABLE 17.7

Basic Formulation Guidelines for Eyeliners

Basic Formulation (%)	
Water	50–70
Colorants	10–20
Alcohol	5–10
Polyols	4–8
Film formers	3–8
Wetting agents	1–3
Gellants	0.50–1.50

bright colorants/pearls (which vastly increase the variability in products), fillers and functional fillers. Manufacturing consists of the molded or extruded lead placed in a slat of wood grooved lengthwise. A second grooved slat is glued onto the first slat and then the two are pressed together.

Lipsticks³⁸

Lipsticks are excellent for giving color to the face for a healthier look, for giving shape to the lips, and depending on the formulation they also have the potential to condition. These products also work towards harmonizing the face with the eyes, hair, and clothes. Uniquely, a lipstick can also make the lips appear larger or smaller depending on the color. Certain pigments will actually give the illusion of thicker, fuller lips. Some pigments also tend to filter the sun as in the case of TiO₂ and ZnO, while some formulations also contain organic sunscreens. Active ingredients can also be found in lipstick which includes herbal type products, and cholesterol derivatives to act as moisturizers. The two types of lipsticks are classical and volatile (solvent) based formulations.

Classical Lipstick

The ingredients included in these types of formulation are emollients, waxes, wax modifiers (plasticizers), actives, fillers (matting and texturizing agents), anti-oxidants/preservatives, and colorants (Table 17.8). Colorants that are widely used in lipsticks are listed below. Note: Fe blue, ultramarines, and Mn violet cannot be used:

- D&Cs: Red #6 and Ba Lake, Red #7 and Ca Lake, Red #21 and Al Lake (stains), Red #27 and Al Lake (stains), Red #33 and Al Lake, Red #30, Red #36, and Yellow #10
- FD&Cs: Yellow #5, Yellow #6 Al Lake, Blue #1 Al Lake
- Iron oxides
- TiO₂
- ZnO
- Pearls

The manufacturing procedure starts with pigments that are pre-milled in either one of the emollients or the complete emollient phase milled by a three roller mill, stone mill, or ball mill. The grind phase is added to the completed emollient phase and waxes, heated (90–105°C), and mixed until uniform. Pearls and fillers are then added to the previously mentioned phases and mixed with shear (if it is necessary)

TABLE 17.8
Basic Formulation Guidelines for Classical Lipsticks

Basic Formulation		
Material	Gloss (%)	Matte (%)
Emollients	50–70	40–55
Waxes	10–15	8–13
Plasticizers	2–5	2–4
Colorants	0.5–3.0	3–8
Pearls	1–4	3–6
Actives	0–2	0–2
Fillers	1–3	4–15
Fragrance	0.05–0.10	0.05–0.10
Preservatives/anti-oxidants	0.50	0.50

TABLE 17.9

Basic Formulation Guidelines for Volatile Lipsticks

Basic Formulation (%)	
Solvents	25–60
Emollients	1–30
Waxes	10–25
Fixatives	1–10
Fillers	1–15
Colorants/pearls	1–15
Fragrance	0.05–0.10

until the materials are homogenized. Then the actives, preservatives, fragrances, and anti-oxidants are added and mixed until uniform. It is important to maintain a temperature slightly above the initial set point of the waxes. Finally, the components are filled.

Volatile Lipstick

These types of formulations are comprised of solvent, emollient, wax, fixative, fillers, actives, preservatives/anti-oxidants, and colorants/pearls (the same as classical lipsticks) (Table 17.9). In a non-transfer lipstick, a proper balance between solvents and emollients is needed to prevent transfer and also to prevent the lipstick from being too dry on the lips.¹⁸

Other lipsticks on the market include semi-permanent color marketed as a two part stick with one portion providing color and the other part providing a moisturizing top coat.¹⁹ Other developments include using interference pearlescent pigments to optically plump lips.²⁰

The manufacturing procedure of volatile lipstick is identical to that of classical lipstick, with the exception that the product should be prepared in a closed vessel to prevent loss of volatile components.

Skin Color Strategies²¹

The development of a worldwide makeup foundation range requires a thorough understanding of the skin color features of individuals around the world. To understand the cosmetic needs of people many tests are designed to assess products and people's perceptions. In one such study, skin color was assessed in five different ethnic groups (French and American Caucasian, Japanese, African-American, and Hispanic-American) and the data obtained was compared with participant's self-perception of skin color, before or after applying their usual foundation product. Skin color was measured using a spectro-radiometer and a spheric lighting device with a charged coupled device (CCD) camera ensuring highly reliable imaging and data acquisition. The diversity of skin types involved in the study lead to defining a large, continuous color space where color spectra from various ethnic groups overlap. Three types of complexions—dark, medium, or light—were distinguished in each group. Only Japanese women did not identify with this lightness scale and considered it made more sense to classify their skin according to a pink-ochre-beige color scale. The approach, however, revealed the great variety of skin colors within each ethnic group and the extent of unevenness. A fairly good agreement appeared between self-perception and the data from color measurements, except in the Hispanic-American group. After foundation was applied, it showed overall consistency with makeup strategy, as described by volunteers, except for the latter group, whose approach looked more uncertain and variable. The findings of the study demonstrate the advantage of combining qualitative and quantitative approaches for assessing the cosmetic needs and expectations of people from different ethnic origins and cultural backgrounds.

Naturals in Cosmetics

Natural ingredients have caused a shift in the cosmetic industry. As consumers educate themselves or become more aware of ingredients in cosmetic formulations, many tend to deviate from those ingredients labeled as cautionary. With this said, a new niche market of natural cosmetics has been instituted. All forms of cosmetics have been touched by the natural shift, with much focus on skin, sunscreen, and hair care. Raw materials deemed as natural are also very broad, including treatments, pigments/pigmentary dispersions, scrubbing beads, fibers, microspheres, cellulose spheres, and sunscreen technologies. Organizations such as ECOCERT, a French organic certification body which conducts inspections in 80 or more countries, have become the seal of approval for many cosmetic formulators to use certain raw materials in their formulations.

Nail Color^{39,40,42}

With a growing number of individuals making time to go to nail salons and likewise doing beauty regimes at home, nail lacquer dominates a large sector of the nail industry. Properties expected from nail lacquer products are gloss, adherence, quick drying, resistance to chipping and abrasion, and water resistance. The main backbone components of nail lacquer formulations are film formers, modifying resins, plasticizers, and solvents. Additions such as suspending agents, UV absorbers, and of course pigments, are likely found in the formulations as well.

The film forming property is essential to achieving a successful polish. Typically nitrocellulose is employed for this purpose. This material is a derivative of cellulose, a polymer made of several anhydroglucose units connected by ether linkages. Used on its own, a hard, brittle film will be produced so it is necessary to modify it with resins and plasticizers to provide flexibility and gloss. A commonly found *resin* in formulation is para-toluene sulfonamide formaldehyde, typically used at levels ranging from 5% to 10%. This type of resin is essential for providing gloss, adhesion, and increased hardness to the nitrocellulose film. Formaldehyde resin has a tendency to cause allergies in some consumers, so other suggested modifiers producing varying results include sucrose benzoate, polyester resin, and toluene sulfonamide epoxy resin. Suggested *plasticizers* used are camphor, glyceryl diesters,²² dibutyl phthalate, citrate esters, and castor oil. It is important to choose appropriate resins and plasticizers which are suitable in particular formulations since individual materials will affect viscosity, dry time, and gloss of the lacquer.

Solvents used in nail lacquer formulation include *n*-butyl acetate, ethyl acetate, and toluene, which together constitute approximately 70% of the product when referring to cream and pearl nail lacquers. Toluene has been found to be a reproductive toxicant and phthalates have been banned in most countries for toxicological reasons. So most nail enamels today are toluene, formaldehyde, and phthalate free. Cream shades may be sheer or full coverage using TiO₂ as the primary pigment. Pearlescent nail polish usually contains bismuth oxychloride and/or TiO₂ coated micas and may even contain guanine-natural fish scales.

Top coats that are used to enhance gloss, extend wear, and reduce dry time are usually made with high solids and low boiling point solvents. Most top coats are nitrocellulose based. Cellulose acetate butyrate (CAB) has been used as a substitute for nitrocellulose in non-yellowing top coats, but does not adhere as well to the nail.²³ Base coats are used with the purpose of creating a nail surface with which the nail lacquer will have better adhesion. Different auxillary resins such as polyvinyl butyral have been used in nitrocellulose systems.

Colorants in nail lacquer include TiO₂, iron oxides, and most organic and pearlescent pigments. Soluble dyes are not used due to their staining effects on skin and nails. To reduce the settling of heavier pigments, treatments such as silicone²⁴ and oxidized polyethylene²⁵ are used to prevent this. Modified clays derived from bentonite and/or Hectorites are used to suspend the pigments and make the nail enamel thixotropic and brushable.

The manufacturing of nail lacquer needs to be carried out using facilities that are familiar with the hazards of nitrocellulose and solvents. The procedure consists of two separate operations starting with manufacturing and compounding of the lacquer base, and then coloring and matching of the shades. For advertising claims and in some cases added effectiveness, it is common to see additions such as fibers, polyamide resins, and other treated items. When evaluating finished product nail polish, the criteria considered include color, application, wear, dry time, gloss, and hardness.

Generally, water-based nail polish contains a binding agent, a polymer or co-polymer, wetting agent(s), and a drying accelerator. As environmental consciousness rises, cosmetic firms are looking toward products which are environmentally friendly. Water-based nail polish, where water is the main solvent, is a low volatile organic compound (VOC), has no solvent odor, and is non-flammable. Most of the water-based formulations to date, when compared to lacquer ones, have a longer drying time, inferior wear, and inferior adhesion.²⁶

Today, recent patents and new color effects have created many new products. Many new shades have been developed with higher levels of mica and aluminum flakes to give a bright mirror-like appearance on the nail. Replacement options for nitrocellulose and trends with natural or sustainable ingredients, together with improvements in wear, have also been found to excite this market. Bioactives are also found in nail care products such as cuticle massage creams and oil, cuticle removers and softeners, and nail hardeners. Vitamins like aloe extract, seaweed extract, myrrh, milk, keratin amino acids, and other botanical extracts are also common in formulations for moisturizing claims.

The range of innovative products to hit the market has been extensive in the past years. A two-step acrylic color and sealer²⁷ has been developed to provide longer wear than most conventional nail enamels. Furthermore, products such as dry nail polish, UV curable, and light emitting diode (LED) curable gel nail polish are also trending in popularity. Also, crackle or shattered nail polish and magnetic nail polish have been a recent development.²⁸

Film Formers

Film formers can be essential in a variety of formulations to impart adhesion and substantivity. Furthermore, with these types of products, water resistance, rub resistance, and transfer resistance can be enhanced. Film formers can find applicability in skin, eyelash, hair, or nail applications. On the market, there are a variety of film formers including ones that are wax-resin composites, and oil solubles. These products have no odor, impart gloss, and aid in the suspension of pigments for good color stability. Usage levels vary depending on formulation but a typical range is 5%–20%.

Quality Control of Colorants

Establishment of Standards

Prior to purchasing a material, it is essential to establish a standard in agreement with the supplier, which typically means evaluating at least three lots of the same material. It is essential that the supplier and end user are in agreement about specifications, standards, and test methods. This will ultimately assure the end user that product development is executed with a material representative of the supplier's production.

Test Methods

Shade Evaluation

The test method employed should forecast performance of the colorant under actual usage conditions. Note: The light source for visual evaluations needs to be specified.

TABLE 17.10

Dispersion Equipment and Vehicles Used in Dispersions

Vehicles	Dispersion Equipment
Talc	Osterizer
Nitrocellulose lacquer	Hoover muller
Acrylic lacquer	Three roll mill
Castor oil	Ball mill

- Dyes—Visual or spectrophotometric evaluation of solutions.
- Pigments—Visual or instrumental evaluations are made on wet or dry dispersions prepared under defined conditions to a defined degree of dispersion. Pigments cannot be evaluated in their “as received” state due to a variable degree of agglomeration (Table 17.10).

Heavy Metals

Heavy metal assessment is performed using methods such as wet chemicals, atomic absorption spectroscopy (AAS), and inductive coupled plasma (ICP).

Particle Size

Particle sizes are assessed using methods such as wet/dry sieve analysis, optical microscopy, scanning electron microscopy (SEM), transmission electron microscopy (TEM), laser diffraction, and sedimentation.

Bulk Density

This property can be assessed using a Fischer–Scott volumeter.

Color Regulations

Color Additive Regulation

In the past, colorants have been used in cosmetics without consideration of their toxicity. Presently, most countries have regulations that control the type and purity of colors that may be used in cosmetic applications.

United States: Food and Drug Administration (FDA)

21 CFR 73, 74: *Positive list*.²⁹ Colors listed for general cosmetic use, including eye area only if stated specifically, or external only, meaning no contact with mucous membranes.

Hair dyes and true soaps are exempt.

Europe (EU): European Commission (EC)

Directive 76/768:

*Annex IV*³⁰: *Positive list*. Coloring agents allowed for use in cosmetic products.

Annex II: Negative list. Substances that must not be part of cosmetic products (not specific for colorants).

Japan: Ministry of Health and Welfare (MHW)

MHW ordinance No. 30³¹: Positive list. Coal-tar colors.

Pre-market approval by MHW for all other cosmetic ingredients, including inorganic and natural colorants.

Color Additive: Definitions**Primary/Straight Color**

A color that is pure, containing no extenders or dilutents.

Dye

A color that is soluble in the medium in which it is dispersed (e.g., FD&C Blue #1).

Pigment

A color that is insoluble in the medium in which it is dispersed (e.g., FD&C Blue #1 Lake, black iron oxide).

Lake*

A water insoluble pigment composed of a water soluble straight color strongly absorbed onto an insoluble substratum through the use of a precipitant (e.g., FD&C Blue #1 Lake).

Generally 10%–40% color.

Toner

A pigment that is produced by precipitating a water-soluble dye as an insoluble metal salt (e.g., D&C Red #6 barium salt, D&C Red #7 calcium salt).

Toner Pigment

A pigment that on the basis of its chemistry precipitates as it is formed (e.g., D&C Red #36).

Extender

A pigment diluted on a substrate (a) during manufacture by precipitation or (b) post-manufacture by intimate milling or mixing.

United States Regulations**21 CFR Part 73 (1): Listing of Color Additives Exempt from Certification**

Inorganic pigments, powdered metals, and naturally derived colorants approved for food, drug, and/or cosmetic use.

Listed permitted usages: food, ingested/externally applied drugs, general cosmetic, eye area only if mentioned, external (no mucous membrane) that is ultramarines, ferric ammonium ferrocyanide not permitted in lip or bath products.

21 CFR Part 74 (1): Listing Color Additives Subject to Certification

Synthetic organic dyes and pigments. Each batch must be submitted by the manufacturer to the FDA for certification that specifications are met.

* The FDA has considered any certified colorant mixed with a diluent to be a Lake (D&C Red #30 plus talc; D&C Red #7 CA Lake on calcium carbonate).

Permitted usages, as in Part 73. Six certified organic dyes and their lakes are now permitted for eye area use: FD&C Blue #1, FD&C Red #40, FD&C Yellow #5, D&C Green #5, D&C Black #2, and D&C Black #3.

21 CFR Part 82 (1): Listing of Certified Provisionally Listed Colors

Lakes²

FD&C: Aluminum or calcium salt on alumina.

D&C: Sodium, potassium, barium, calcium, strontium, or zirconium salt on alumina. Blanc fixe, glossy white, clay, TiO₂, ZnO, talc, rosin, aluminum benzoate, calcium carbonate.

A salt prepared from straight color (e.g., D&C Red #6) by combining the color with a basic radical.

Proposed Permanent Listing of Color Additive Lakes (FR Vol. 61 #43), March 4, 1996³²

List substrate (e.g., D&C Red #27 aluminum lake on alumina).

Extenders of insoluble straight colors will no longer be called lakes (e.g., D&C Red #30).

Permit blends of previously certified straight colors in a lake (e.g., FD&C Blue #1 and Yellow #5 Aluminum lake).

All lakes to be prepared from previously certified batches of straight color would necessitate process changes for D&C Red #6, D&C Red #7, and D&C Red #34.

Abbreviations permitted for cosmetic ingredient labeling, omitting FD&C, precipitate and substrate designation (e.g., Blue 1).

European Regulations

Directive 76/768, as amended (2).

Annex IV: Listing of Coloring Agents Allowed in Cosmetic Products

List by color index number.

Part 1: Permanently listed.

Part 2: Provisionally listed.

Four fields of application and restriction of use:

1. All cosmetic products.
2. All cosmetic products except those intended to be applied in the vicinity of eyes; in particular eye makeup and eye makeup remover.
3. Allowed exclusively in cosmetic products intended not to come into contact with mucous membranes (including eye area).
4. Allowed exclusively in cosmetic products intended to come into contact briefly with skin (not permitted in nail preparations).

Lakes and Salts

If a color index number is listed in Annex IV then the pure color plus its salts and lakes are allowed unless prohibited under Annex II (the list of substances that cosmetics may not contain). *Exception:* barium, strontium, and zirconium.

TABLE 17.11

List of Ingredients with Permitted Usage to Fall under the Purity Criteria

Amount	Ingredient
<5 ppm	As
<20 ppm	Pb
<100 ppm	Sb, Cu, Cr, Zn, BaSO ₄ , separately
<200 ppm	Of those together
None detected	Cd, Hg, Se, Te, Th, U Cr ⁶⁺ or soluble Ba

Prohibited under Annex II but where the footnote “3” appears in Annex IV which states “the insoluble barium, strontium, and zirconium lakes, salts, and pigments...” shall also be permitted. The material must pass the test for insolubility, which will be determined by the procedure in Article 8 (insoluble in 0.1 N HCl).

Purity Criteria

Only colors designated with the letter “E” must meet the general specification for food colors since they are also permitted for food use.

The sixth amendment to the directive is currently adopted (Table 17.11). Update of purity criteria is being considered and test methods may be stipulated.

Japanese Regulations

MHW ordinance No. 30 (1966) as amended by MHW ordinance No. 55 (1972) (3).

Positive List

Eighty-three coal-tar colors must be declared on the cosmetic product label. Fields of application include oral, lip, eye area, external, and rinse off.

Inorganic/Natural Colorants

Listings are found in the Japan standards of cosmetic ingredients (JSCI). Specifications are found in the comprehensive licensing standards (CLS) of cosmetics by category while test methods are included in the Japan cosmetic ingredient dictionary.

U.S. Colorants Not Permitted/Restricted in Japan

Pigments and substrates which fall into this category are listed below (Table 17.12).

TABLE 17.12

U.S. Colorants Restricted in Japan

Pigments

D&C Red #6	Ba lake
D&C Red #21	Al lake
D&C Red #27	Al lake
D&C Red #33	Zr lake
D&C Orange #5	Al lake

Substrates

Aluminum benzoate	0.5% maximum in lipstick
Rosin	7.0% maximum in lipstick
Calcium carbonate	Not permitted

Acknowledgments

I would like to extend my gratitude to Kobo Products, Inc. for broadening my expertise in the cosmetic industry.

I would like to express what a pleasure it was to be invited by and subsequently co-author this chapter with my colleague and dear friend Mitchell L. Schlossman as I always value our collaborative work. I would like to give a special thank you to another colleague, Alana Kelly, for her in-office support.

I would like to extend my thoughts to my beloved family (EG, MJCG, GG, EC, AG, IG, and KR) for your endless support and motivation. Finally, to the Lord, for every opportunity sent along my path and for giving me the ability to convey knowledge.

—Giorgiana Giancola

I would like to first thank Howard I. Maibach, MD, professor of dermatology, University of California, San Francisco for inviting me to collaborate with others in this book.

In preparing this chapter much is owed to Kobo Products, Inc. for several of the formulations and technical presentations within.

There are two others to whom it is owed a special gratitude, Dr. Giorgiana Giancola, co-author and contributor. Her efforts and intellect are well noted and appreciated. Also, my wife, Barbara Harrison-Schlossman, who encouraged me and helped organize my presentations.

—Mitchell L. Schlossman

REFERENCES

1. Juster NJ. Color and chemical constitution. *J Chem Edu* 1962;39: 596–601.
2. Knowlton JL, Pearce SEM. Decorative cosmetics. In: *Handbook of Cosmetic Science and Technology*. Peter E and Howard IM (Eds). Oxford: Elsevier Advanced Technology, 1993, pp. 128, 143, 145.
3. EPA, U.S. *Sunscreen the Burning Facts*. EPA 430-F-06-013, September 2006.
4. Center for Disease Control and Prevention. *Basic Information About Skin Cancer*: http://www.cdc.gov/cancer/skin/basic_info/ May 2013.
5. FDA, Dockets Management Branch. *Overview of Principles*. https://www.fda.gov/ohrms/dockets/dailys/oo/Seo00/090800/c000581_tab_2.pdf. 2000, pp. 3–5.
6. Henry LW, Wang SQ. *The Skin Cancer's Foundation Guide to Sunscreens* (Interview) <http://www.skincancer.org/prevention/sun-protection/sunscreen/the-skin-cancer-foundation-guide-to-sunscreens>, 2012.
7. Suzuki R, Muyco J, McKittrick J, Frangos JA. Reactive oxygen species inhibited by titanium oxide. *J Biomed Mater Res* 2003: 396–402.
8. Smijs TJ, Pavel S. Titanium dioxide and zinc oxide nanoparticles in sunscreens: Focus on their safety and effectiveness. *Nanotechnol Sci Appl* 2011;4:95–112.
9. National Cancer Institute. *Melanoma and Other Skin Cancers*. <http://www.cancer.gov/cancertopics/wyntk/skin/page5> (cited: March 27, 2014).
10. Smith HM (ed.) *High Performance Pigments*. Weinheim: Wiley, 2002, pp.77–88.
11. Schlossman ML. Method of incorporating cosmetic pigments and bases into products containing oil and water phases, US 4,877,604, 1986.
12. Elsner P, Howard HI (eds). *Cosmeceuticals and Active Cosmetics: Drugs versus Cosmetics*. Boca Raton: CRC Press, 2005.
13. *Hybrid Surface Treatment*. www.koboproducts.com (2012, cited July 24, 2013).
14. Schlossman D, Shao Y. Natural ester, wax or oil treated pigment, process for production thereof, and cosmetic made therewith. *Application 20100136065 A1*. U.S., 2010.
15. Baldwin AR. Seventh International Conference on Jojoba and Its Uses. *Ame Oil Chem Soc* 1989; 62:273–314.
16. *Fluoro Silane Treatments*. www.koboproducts.com (cited July 24, 2013).
17. Dweck AC. Foundations—A guide to formulation and manufacture. *Cosmet Toilet* 1986;101:41–44.

18. Castrogiovanni A., Barone SJ, Krog A, McCulley ML, Callelo JF. Cosmetic compositions with improved transfer resistance. 5,505,937. U.S., 1996.
19. Drechsler LE, Rabe TE, Smith ED. Transfer resistant cosmetic compositions. 6,340,466. U.S., 2000.
20. Cohen ID, Oko J. Shadow effect cosmetic composition. 6,428,773. U.S., 2000.
21. Caisey L, Grangeat F, Lemasson A, Talabot J, Voiriu A. Skin and makeup strategies of women from different ethnic groups. *Int J Cosmetic Sci* 2006;28:427–37.
22. Castrogiovanni A, Sandewicz RW, Amato SW. Shadow effect cosmetic composition. 5,066,484. 1991.
23. Martin, FL, Onofrio MV. Nail polish top coat. 5,130,125. U.S., 1992.
24. Socci RL, Ismaier AA, Castrogiovanni A. Nail enamel containing silicone-coated pigments. 4,832,944. U.S., 1989.
25. Weber RA, Frankfurt CC, Penicnak AJ. Laboratory device method for treating samples. 5,174,966. U.S., 1992.
26. Schlossman ML. Additives for water-base nail polish. *J. Soc Cosmetic Chemists* 1994;50:105–9.
27. Armstrong G, Callelo J, Patil A, Pagamo F, Sandewicz R. Cosmetic compositions containing silicone/organic copolymer. 20,018,759. U.S., 2002.
28. Pagano F. A review of nail polish. *J Cosmet Toilet* 2011;126:380.
29. Code of Federal Regulations, Title 21, April 1, 1998. pp. 1–99.
30. *EC Cosmetics Directive 76/768/EEC*. Annex IV, Part 1, September 3, 1998.
31. Ministry of Health and Welfare Ordinance, Japanese Standard for Cosmetics. No. 30, August 31, 1966.
32. Federal Register; Food and Drug Administration, Volume 61, 8372. March 6, 1966.
33. Miyoshi R. 4,606,914. U.S., 1986.
34. Miyoshi R. and Imai I. Pigments and extender pigments which are surface treated with hydrogenated lecithin, and cosmetics containing the same. 4,622,074. U.S., 1986.
35. Hunting A. (eds). Face cosmetics. In: *Decorative Cosmetics*. Weymouth: Michelle Press, 1991, p. 3.
36. GE Silicones. *Personal Care Formulary*. Waterford, NY: GE Silicones, 1996, 149, 151.
37. Schlossman ML. Application of color cosmetics. *Cosmet Toilet* 1985;100:36–40.
38. Bryce DM. Lipstick. In *Poucher's Perfumes, Cosmetics, and Soaps*. London: Chapman and Hall, 1992, p. 234.
39. Schlossman ML. Manicure preparations. In *Poucher's Perfumes, Cosmetics, and Soaps*. London: Chapman & Hall, 1992, pp. 253–54.
40. Schlossman ML. In Butler H (ed.) *Poucher's Perfumes, Cosmetics and Soaps*. Amsterdam: Kluwer Academic, 2000.
41. Hunting A. Eye cosmetics. In: *Decorative Cosmetics* Weymouth: Michelle Press, pp. 170, 173, 174.
42. Patil AA, Sandewicz RW. Nail lacquer technology. *Soc Cosmetic Chemists Monograph No. 6*, 2000, pp. 53–67.

18

Hair Cosmetics and Cosmeceuticals

Robin Alexander

Definitions of Terms Used for Components of Hair Products

The following definitions cover the majority of terms regarding shampoos, conditioners, and fixatives. However, authoritative books and articles regarding the composition and use of hair products are suggested for further reading.¹⁻⁸

Acrylic resins: Resins composed of polymers or copolymers of acrylic and methacrylic acids.

Active ingredients: Active ingredients are substances that are the main pharmacologic components in medicines that function to treat a specific condition. Active ingredients added to shampoos for patients with dandruff and psoriasis include tar, selenium, zinc, ketoconazole, and steroids.

Amphoteric surfactants: Detergents that behave as cationic agents at lower pH and anionic agents at higher pH are very mild and are often used with anionic surfactants to form a complex, reducing the tendency for the anionic to adsorb onto hair; betaines, sultaines, and imidazolinium derivatives.

Anionic surfactants: Detergents with a negatively charged polar group are outstanding cleansing agents that produce rich lather; ammonium and sodium lauryl sulfates and ammonium and sodium laureth sulfates.

Bimodal acrylics: Newer resin copolymer composed of two different acrylic molecules, one with anionic and the other one with cationic functionalities. These have good affinity for the hair surface and are easily washed out.

Block copolymers: Linear heteropolymers composed of homopolymer “blocks” of different monomers.

Bodying agents and thickeners: Improve thickness and creaminess of the formulation. This is usually achieved by using salt, fatty alcohols, waxes, or gums. Gums have the advantage of acting as foam stabilizers and suspending agents able to keep insoluble particles like pigments or zinc pyrithione in suspension.

Bridging agents: Added to enhance adsorption of hydrophobic ingredients like silicones to damaged (hydrophilic) hair.

Cationic conditioning polymers: Modified “quats” with many positively charged quaternized fatty acid groups per molecule and improved rinsability.

Cationic surfactants: Detergents with a positively charged polar group increase the ease of combing and reduces static electricity but are relatively poor detergents and do not lather well; amino esters, long chain amino acids, and quaternary ammonium compounds.

Conditioning polymers: Polymers designed to deposit, adhere, or adsorb to the surface of the hair to improve combability. Most often these are polyquaterniums, cationic conditioning polymers, protein hydrosylates, emollients, silicones, and film forming resins. These are found in conditioning shampoos, conditioners, and some hair fixatives.

Cosurfactant: Secondary detergent in a shampoo or conditioner. Often added to the primary detergent to improve conditioning, enhance foam production, and improve viscosity.

Emollients: Natural or synthetic oils, esters, waxes, and silicones that spread onto hair leaving transparent, water-repelling films; includes argan, coconut, jojoba, olive, or grapeseed oils, and silicones.

Emulsifier: An ingredient that when added to a combination of two unblendable substances allows them to become stable in their blended state.

Foaming agents: Introduces gas bubbles into water and cause shampoo to form suds, which spread the detergent over the scalp and hair. This does not enhance the cleansing of the hair. This may be achieved by the primary surfactant but also by the addition of gums (guar or xanthan) or modified fatty acids.

Fragrances: Impart a pleasing odor and mask the odor of other ingredients. These may be essential oils or artificial fragrances.

Graft copolymers: Linear heteropolymers with branches of one type of monomer “hung” from a main chain consisting of another homopolymer.

Long chain fatty alcohols: High-molecular-weight, straight-chain primary alcohols originally derived from naturally occurring wax esters, as in sperm whale oil, jojoba oil, rapeseed, and mustard seed. These are now prepared from petroleum products. As nonionic surfactants, they are creamy and are often used as conditioners, emulsifiers, emollients, and thickeners; cetyl alcohol, lauryl alcohol, stearyl alcohol.

Natural polymers: Proteins like collagen, keratin, silk, as well as polysaccharides like chitin, cellulose, pectin, xanthum gum, hyaluronic acids, and guar gum.

Nonionic surfactants: Detergents with no polar group are the second most popular group of detergents behind the anionic surfactants. They are very mild and are often combined with anionics or amphoterics for very mild shampoos; polyoxyethylene fatty alcohols, polyoxyethylene sorbitol esters, and alkanolamides.

pH adjusters: Most shampoo systems are alkaline, leading to swelling of the cuticle and increased friction. The addition of a mild acid (citric or glycolic) is designed to alter pH usually to 3.5–4.5.

Polymer: Chemical compound made of small molecules arranged in a simple linear repeating structure to form a larger molecule.

Polyquaterniums or “quats”: Hydrophobic and positively charged quaternized copolymers with various oily “tails” (coconut oil, castor oil, canola oil, or others). As the most important active ingredients in hair conditioners, these are substantive and resistant to rinsing, but may leave the hair lank and greasy; polyquaterniums 1–47. Also found in hair fixative gels to maintain style in high humidity.

Polyurethanes: Resins composed of chains of organic oil joined by urethane links to form long, flexible segments with high amounts of cross linking to make them tougher and more rigid. Derived from natural oils or petroleums, most do not melt when heated and are easily made into foam.

Preservatives: Protect against bacterial contamination and are vital in any product made with water. These are usually organic compounds with acidic properties; parabens and urea derivatives.

Primary surfactant: Principal detergent (usually in a shampoo).

Quaternary ammonium: Positively charged molecule with a central ammonium (N⁺) with four hydrophobic chemical groups attached.

Resin: Sticky natural or synthetic film-forming polymers used in hair fixatives to enhance cohesion.

Sequestering agents: Prevents film on the hair and chelates magnesium and calcium ions so that other salts or insoluble soaps are not formed; polyphosphates and ethylenediaminetetraacetic acid.

Short chain alcohols: Low molecular weight alcohols used mostly as solvents. These are flammable, volatile, and quickly evaporate; ethanol, SD alcohol, SD alcohol 40, isopropyl alcohol, propyl alcohol, and alcohol denat.

Silicones: Versatile polymers derived from sand and silicon-containing minerals used as conditioners, pearlizers, thickeners, foamers, to reduce irritation from surfactants, and non-ionic emulsifiers to help to incorporate sunscreens, fragrances, proteins, pigments, and natural waxes into hair products. Due to hydrophobic nature, these work best with healthy or only mildly damaged hair.

Sorption: The process by which one substance becomes attached to the hair via adsorption, ion exchange, and/or absorption; depends on the charge of the substance, its molecular size, the pH of the hair, the amount of sebum and soil on the surface of the hair, the pH of the medium, ingredients already adsorbed to the hair fiber, duration of contact, temperature, and other components in the formulation.

Substantivity: Persistence of a topically applied substance; determined by the degree of physical and chemical bonding to the surface of the hair and resistance to removal.

Sunscreens: UV absorbers are added for products with clear packaging.

Surfactant: A blended word from the base words “surface acting agent”; usually organic detergents that contain lipophilic (oil attracting) and hydrophilic (water attracting) agents allowing the compound to combine with free lipids and soil and wash them away.

Synthetic polymers: Commonly used petroleum based viscosity modifiers, humectants, emulsifiers, surfactants, and preservatives; polyethylene glycols and acrylic acids.

Visual effects: Improved by coloring agents like D&C or FD&C.

Hair Cosmetics and Cosmeceuticals

Introduction

Hair covers most of the human body. This chapter focuses on scalp hair and summarizes the established information about hair science as it pertains to hair care, hair cosmetics and cosmeceuticals, and previews innovative developments in hair care science.

Why do we care so much about our hair? As one of the most important components of body image, hair is highly prized. Hair loss of any degree and type can lead to depression, loss of self-confidence, low self-esteem, and heightened self-consciousness for both men and women.⁹ Successful treatment of hair loss leads to improvement in quality of life.^{10,11}

Hair is durable, and while it can remain intact 8000 years or more when protected from the sun,^{12,13} it is vulnerable to disease, aging, environmental exposures, and hair care practices.

Hair cosmetics and cosmeceuticals include a myriad of substances including natural, synthetic and biologically derived polymers, detergents, conditioning agents, botanicals, and vitamins found in shampoos, conditioners, and styling products.

The most important interactions of these products with the hair occur at the hair fiber surface, in the first few layers of the cuticle, and in the cortex of damaged hair (Figure 18.1).¹⁴ For this reason, an overview of hair shaft structure and proteins is provided.

Hair Structure and Function

The hair shaft is a non-living structure consisting of an external cuticle, an inner cortex, and, in some hairs, a central open area called the medulla. A cell membrane complex (CMC) formed by fusion of free lipids, lipoproteins, and cell membrane lipids, permeates the fiber holding it together. The top panel in Figure 18.1 shows a schematic of the hair fiber structure.¹⁴ Melanin pigments (not pictured) are embedded in the CMC in the cortex.

The cuticle is composed of extensively overlapping layers of flat, thin cells laid out as roof shingles pointing outward from the root to the tip of the hair of the fiber. It contributes to the follicular anchorage of hair, protects the underlying cortex, and acts as a barrier to water. Each cuticle cell consists of multiple

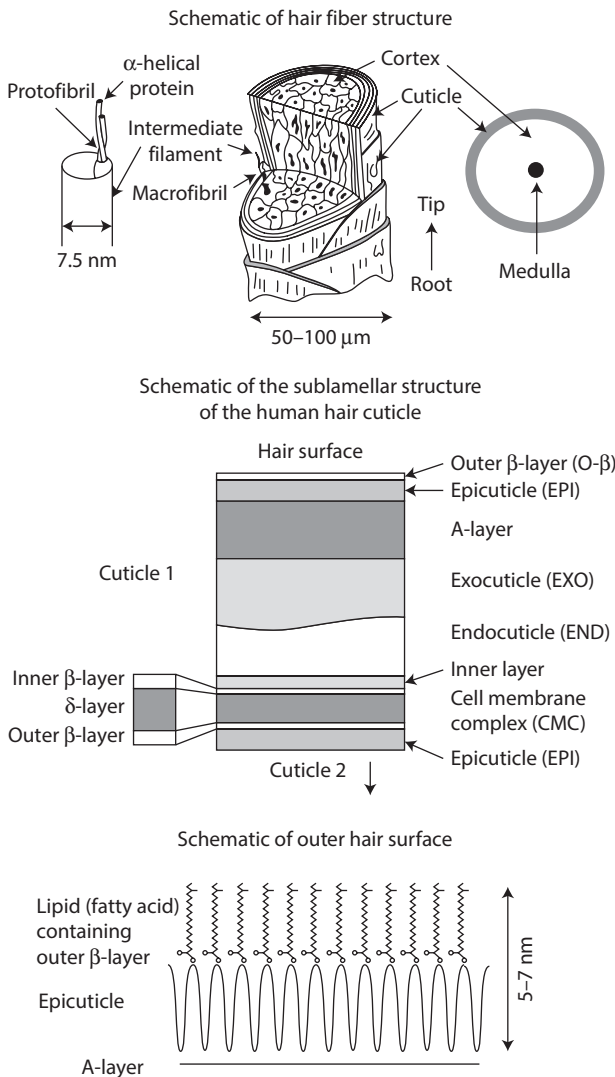

FIGURE 18.1 Schematic of hair fiber structure and cuticle sublamellar structure. (With kind permission from Springer Science+Business Media: *Biophysics of Human Hair: Structural, Nanomechanical and Nanotribological Studies*. 2010, Bhushan B. Heidelberg: Springer.)

layers that differ in amino acid composition and concentration of cross linking. The center panel of Figure 18.1 shows a schematic of the structure of the human hair cuticle.

Each cell of the cuticle is covered by a thin lipid monolayer (composed of 18 methyleicosanoic acid) covalently linked to underlying proteins of the cuticle via thioester bonds. The lower panel of Figure 18.1 shows a schematic of the outer hair surface. **Figure 18.2** shows electron micrographs of the hair fiber shaft and its cross-section (above) and the cuticle (middle).¹⁵ The schematic below shows the layered structure of the cuticle.

The cortex comprises the majority of hair fiber mass and imparts mechanical strength to the hair shaft. Composed of long, thin cortical cells that interdigitate in a longitudinally oriented configuration parallel to the long axis of the hair, it is permeated by the cortical cell membrane complex (CMC). The CMC, composed of protein and lipid, forms a continuous phase throughout the hair fiber and glues the fiber together by fusing cortical cells. Lipids, localized to both the cuticle surface and CMC, consist mainly of cholesterol esters, free fatty acids, cholesterol, ceramides, cholesterol sulfate, and 18-MEA.

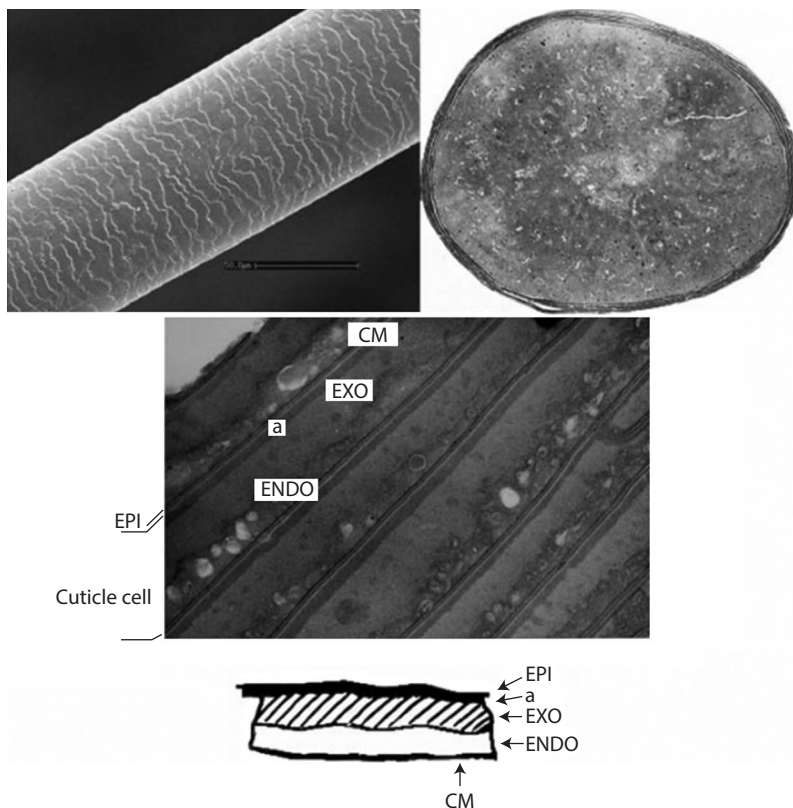

FIGURE 18.2 A scanning electron micrograph showing the hair fiber shaft and its cross-section (above) and transmission electron micrograph of the hair cuticle (middle). The schema (below) shows the layered structure of the cuticle. EPI, epicuticle; a, a-layer; EXO, exocuticle; ENDO, endocuticle; CM, cell membrane. (Reproduced with permission from Popescu C, Höcker H. *Chem Soc Rev* 2007;36(8):1282–91.)

These contribute to hydrophobicity, sorption, cohesion, mechanical strength, and changes of the hair in response to water, heat, and hair products.

Melanin pigments impart color to the shaft and provide weak photoprotection. Hair color ranging from black, brown, and blond to red is produced by the quality, quantity, and ratio of the black–dark brown eumelanin and the reddish-brown pheomelanin granules produced by melanocytes in the hair bulb.¹⁶ Figure 18.3 shows a high powered photograph of the dermal papilla demonstrating the intimate association of melanocytes to the hair matrix in anagen.

The medulla is a disorganized and open area at the fiber’s center composed of loosely packed spherical and hollow cells bound together by a CMC-like material. Associated with coarser hair, its function is unknown.

All 20 natural alpha-amino acids are present in hair. Hair proteins are distinguished from epidermal proteins by relatively higher cysteine content found in the cortex and cuticle. This reflects the increased disulfide bonds that create “hard keratins” and distinguishes them from the “soft keratins” of the stratum corneum.¹⁷ Intermolecular links between hair polypeptide chains in the hair fiber are stabilized by ionic hydrogen bonds, salt bridges, and covalent disulfide bridge between two cysteine residues. Covalent isodipeptide bridges between glutamic acid and lysine residues are additionally found in the cuticle. Figure 18.4 shows some of the bonds between the polypeptide chains of the hair.¹⁴

Salt bridges and hydrogen bonds are more sensitive to stretching, bending, twisting, humidity, and heat. These bonds confer flexibility to the hair shaft allowing for grooming without breakage.

The physical and cosmetic properties of healthy, treated, damaged, and damaged–treated hair can be measured and quantified objectively using single fiber and hair assembly (head, hairpiece, or swatch)

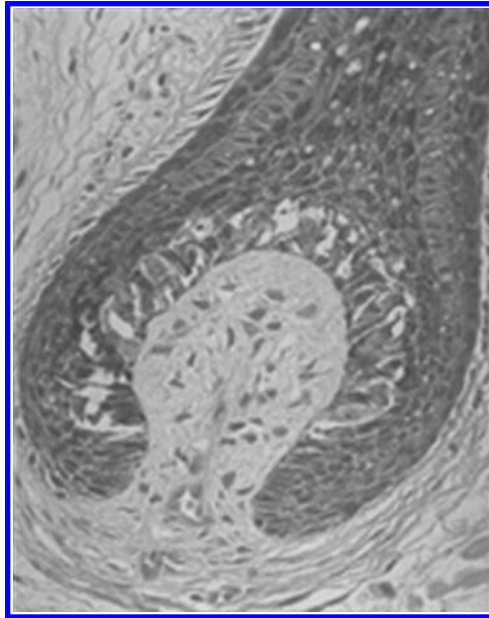

FIGURE 18.3 Photo of dermal papilla.

studies. These properties are well established^{2,3,6,18,19} and include pH, charge, hydrophobicity, response to heat, water, stretching, bending, twisting, as well as luster, combability, friction, electrostatic charge, curl, deformability, cohesive set, elasticity, volume, body, and feel. Torsional (twisting) studies are becoming as important as tensile (stretching) studies as these provide information both about cuticular changes as well as damage and repair of the cortex.²

The surface of the hair is hydrophobic due to the combination of sebum and environmental contaminants present on the surface of the hair, thioester linkages with 18-MEA, and covalent disulfide and isodipeptide bonds in the cuticle. Hair has a net negative charge above pH 3.67, the isoelectric point of hair,²⁰ due to the relative concentrations and interactions of the amino acid side groups as well as the acidic free carboxyl and the basic N terminal end groups. The thiol groups of cysteine, the amino acid residues of lysine and histidine, and the amino end groups are important sites for the covalent attachment of chemical reagents and reactive dyes.

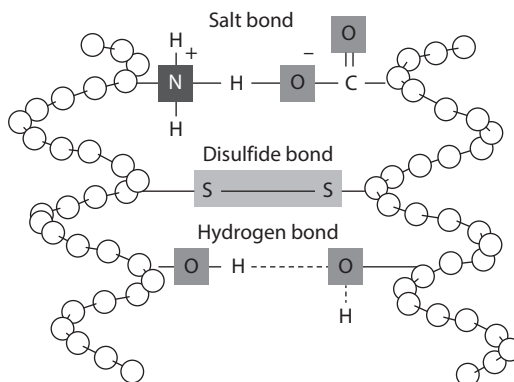

FIGURE 18.4 Various bonds within hair cellular structure. (With kind permission from Springer Science+Business Media: *Biophysics of Human Hair: Structural, Nanomechanical and Nanotribological Studies*. 2010, Bhushan B. Heidelberg: Springer.)

TABLE 18.1

Traditional Racial Characteristics of Hair

Hair Type	Diameter (μm)	Pigmentation	Cuticle	Medulla	Cross Section
Caucasoid	70–100	Evenly distributed eumelanin and pheomelanin	Medium	Missing or fragmented	Round to oval
Asian	90–120	Eumelanin dominance and even distribution leads to dense dark hair	Thick	Thick; usually unbroken	Round
African	60–90	Eumelanin rich but concentrated in specific areas, so the color of each hair is less uniform than in the other two	Thin or absent	Missing or fragmented	Elliptical or flat

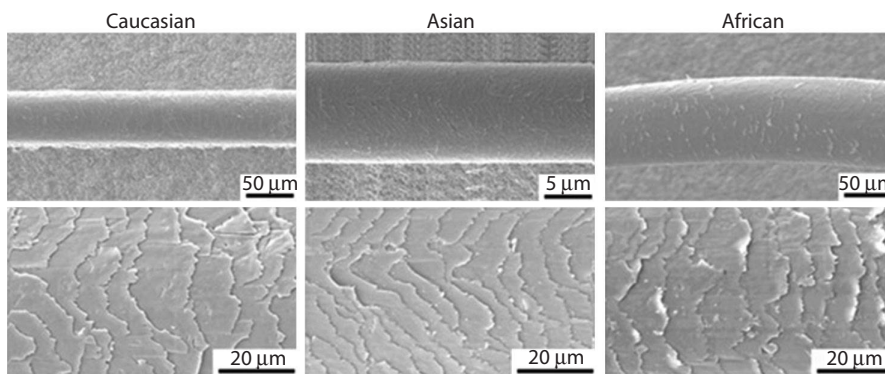

FIGURE 18.5 SEM images of various hair. (With kind permission from Springer Science+Business Media: *Biophysics of Human Hair: Structural, Nanomechanical and Nanotribological Studies*. 2010, Bhushan B. Heidelberg: Springer.)

Hair fragility due to aging,² very curly hair,²¹ and genetic^{22,23} or acquired²⁴ hair shaft disorders increases susceptibility to weathering, a response to grooming, coloring, perming, straightening, sun, swimming, chlorine, heavy metals, and aging.

Global variations of human hair²⁵ helps us to better understand the interactions between hair and hair products experienced by the three major ethnic groups—Caucasoid, Asian, and African. Table 18.1 shows the traditional racial characteristics of hair, Figure 18.5 shows SEM images of Caucasian, Asian and African hair,¹⁴ and Figure 18.6 shows SEM images of racial hair in cross sections demonstrating variation in the fiber shape, cortex/medulla region, and the cuticle.¹⁴

As racial classifications fail to account for the diversity of hair qualities due to variations within ethnic groups and mixed race, dermatologists²⁶ and researchers have looked for additional approaches that are more meaningful. The “hair curvature method” based on longitudinal shape of the hair fiber (curve diameter, curl index, and number of waves and twists per unit area) has been studied, and eight well-defined categories ranging from straight to wavy to very curly have been established, independent of race and ethnicity.^{27,28} Hair fiber curvature has evolved to be vitally important to all cosmetic properties; application of this method is currently used to study the effects of products on the hair fiber and hair assembly.²

Shampoos

Shampoos are designed to cleanse the scalp and beautify the hair. They are intended to remove highly variable soil types while conditioning the hair, leaving it pleasantly fragranced and the scalp dandruff free. Water comprises about 70%–80% of shampoo formulas. It makes the solution easy to spread, dilutes the surfactants, and keeps the formula inexpensive.

Surfactants make up 10%–15% of the product. The most popular primary surfactants in shampoos are anionic and are derived from natural fatty acids (soap) or the lauryl and laureth sulfates. Soaps leave

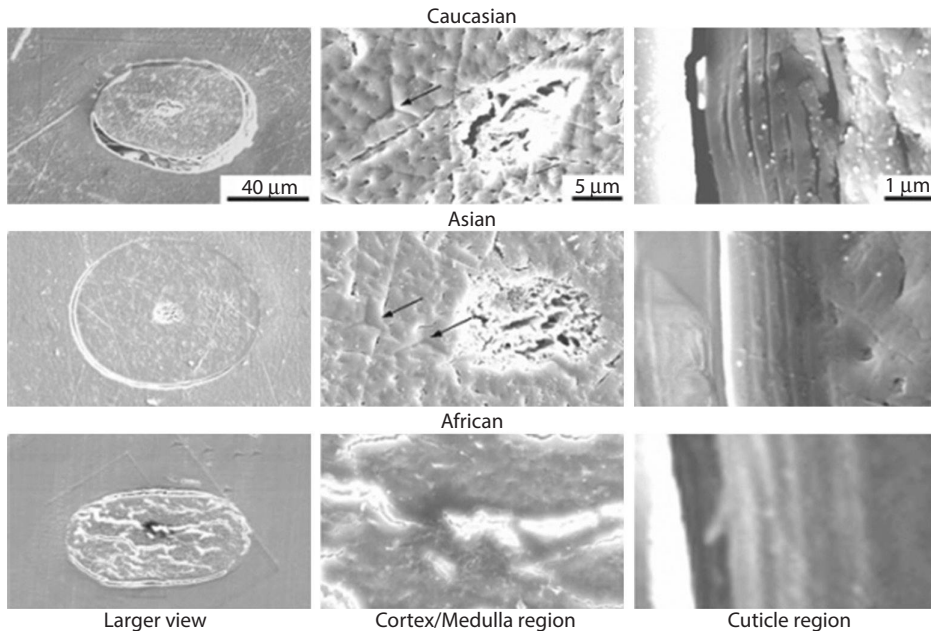

FIGURE 18.6 SEM images of virgin hair cross section (Wei et al., 2005). (With kind permission from Springer Science+Business Media: *Biophysics of Human Hair: Structural, Nanomechanical and Nanotribological Studies*. 2010, Bhushan B. Heidelberg: Springer.)

“scum” when used with hard water. Lauryl sulfates are good cleansers, but are hard on the hair, while the laureth sulfates leave the hair in better condition.

A shampoo usually contains a mixture of several surfactants to ensure all promised cosmetic benefits are met. These are combined with additional additives to improve conditioning benefit, stabilize the product, and increase its appeal, or to deliver active ingredients to the scalp.

The majority of shampoo components are non-substantive. Certain ingredients including vitamins, proteins, and herbal extracts tend to be washed off and may have limited impact on the performance of shampoos. However, this is an area worthy of future study to evaluate the potential benefits to hair and scalp.

For the consumer to choose an appropriate product, shampoos are characterized by hair type, degree of hair damage, amount of oil, type of oil, presence of oxidized metals, product build-up, ocular safety, and the presence of active agents. Choice is based on hair quality, color, length, hair care habits, and problems related to the condition of the scalp.

Clarifying shampoos contain an active chelating agent to bind metals and can be used after swimming or to remove build-up of conditioners. Baby shampoos contain mild cleansing agents which are non-irritating to the eyes due to amphoteric and a lower anionic detergent content. Dry shampoos are based on powders such as starch, silica, or talc that physically absorb excess sebum from the hair. Hypoallergenic shampoos avoid using substances that are likely to cause contact allergy and tend to be “fragrance-free” with only low levels of masking fragrances permitted. In color-enhancing shampoos, surfactants are mixed with small molecules of color pigment. Some shampoos contain sunscreens, but most are washed away. The quaternized ultraviolet (UV) absorber, cinnamidopropyltrimonium chloride (CATC), delivered via a simple rinse-off shampoo system, has been found to be substantive and effective in protecting hair from UV damage and fading. Additional decreases in wet combing force validated an observed conditioning effect.²⁹

Typically, shampoos are in contact with the skin for brief periods of time, and therefore do not commonly cause irritant or allergic contact dermatitis. True contact allergy to shampoo is rare; when it occurs it is often due to preservatives, fragrances, and botanicals.³⁰

The addition of cationic polymers and silicones has improved the ability of shampoos to condition the hair and forms the basis for “2-in-1” shampoo systems. Stability and delivery problems are overcome by adding bridging agents and emulsifiers.

Shampoos formulated for normal, oily, or dry hair can be constructed by varying the primary and secondary surfactants and the addition of conditioners. Conditioning shampoos contain additional conditioning agents that neutralize static electricity, improve the luster, and make the hair easier to comb. These include “quats,” cationic conditioners, vegetable oils, waxes, mineral oils, hydrolyzed protein, glycerin, and silicones.

Conditioners

Removal of sebum by shampooing, along with weathering of the hair shaft, creates the need for a sebum-like substance to maintain the appearance of healthy hair and to recondition and protect damaged hair. Hair conditioners supply the hair with the positive attributes of sebum while avoiding the greasy appearance of excessive sebum and dirt. The fundamental action of all conditioners is sorption to the hair fiber to make the hair easier to comb while wet and dry. Conditioned hair has a smoother texture, improved luster, and less susceptibility to tangling. The type of conditioner required depends on individual variations in hair curvature plus degree of hair shaft fragility. Vehicles include rinses, creams, balsams, and hair masks. The most common primary ingredients in hair conditioners are the cationic polyquaterniums and conditioning polymers, long chain fatty alcohols, film-forming agents, silicones, oils, and protein hydrosylates. Figure 18.7 shows the interactions between a cationic conditioner and the cuticle surface.¹⁴ Figure 18.8 shows SEM of untreated and conditioner treated hair.¹⁴

Film-forming conditioners coat the hair shaft with a thin layer of oil, wax, or polymer. Substances include mineral oil, long chain fatty alcohols, triglycerides, true oils, and waxes. They are often found in conditioners for dry, coarse, or kinky hair.

Protein conditioners, composed of hydrolyzed animal collagen, keratin, placenta, and soy and wheat polypeptides, penetrate damaged hair shafts via cracks in the cuticle and cortex due to weathering. These increase tensile and torsional strength and temporarily mend split ends. These are found in short-contact, instant, and leave-on conditioners indicated for fine or damaged hair.

Silicone conditioners deposit a water resistant coating on the hair shaft that remains after rinsing to reduce static electricity and friction while imparting shine. Silicones adsorb via a hydrophobically driven process² and, as neutral hydrophobic agents, they work best on hair that is undamaged or only lightly damaged,² unless combined with a bridging agent. Viscosity builders, pH adjusters, colors, and preservatives are also found.

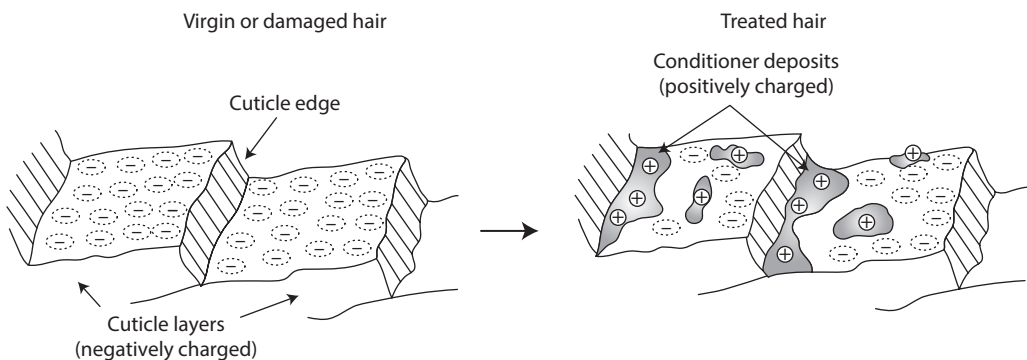

FIGURE 18.7 Negatively charged hair and the deposition of positively charged conditioner on the cuticle surface. (With kind permission from Springer Science+Business Media: *Biophysics of Human Hair: Structural, Nanomechanical and Nanotribological Studies*. 2010, Bhushan B. Heidelberg: Springer.)

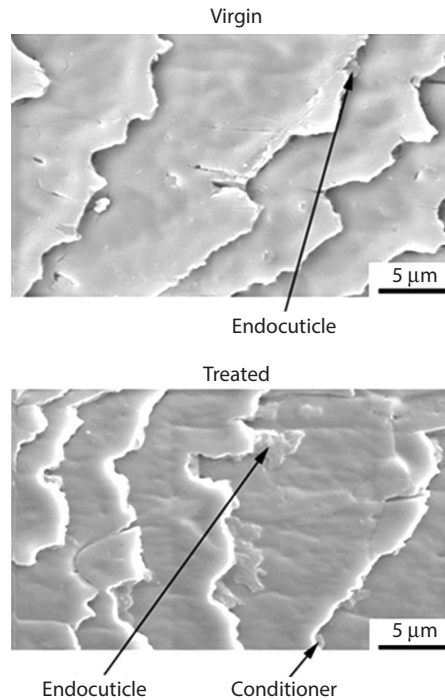

FIGURE 18.8 SEM images of Caucasian virgin and treated hair. (With kind permission from Springer Science+Business Media: *Biophysics of Human Hair: Structural, Nanomechanical and Nanotribological Studies*. 2010, Bhushan B. Heidelberg: Springer.)

TABLE 18.2

Conditioner Types

Type	Directions	Indication
Instant or rinse-out	Applied immediately after shampooing then rinsed	Aids in detangling and helps to remove soap residue
Deep or repair treatment	Applied either before or after shampooing for 20–30 min or more	Fills in the cracks in fine, weathered, or chemically treated hair
Leave-in	Applied to towel dried hair prior to styling	Improves combability and protects hair from heat

Conditioner types include instant conditioners, deep conditioners, and leave-in conditioners. These vary as to indication, duration, and timing of application. Table 18.2 shows conditioner types.

Fixatives

Hair fixatives are aerosols, sprays, gels, mousses, and lotions designed to make hair more amenable to styling, to protect it from the effects of hair styling techniques, or to allow a style to last until it is touched-up or shampooed. These can additionally cover gray, create luster, reduce frizz, define curls, and add hold, body, and volume. The ideal fixative properties include style hold, easy application to wet hair, quick drying, and non-powdery, sticky, or flaky, as well as removable by shampoo, leading to increased combability and luster. Some of the most widely used fixative polymers include resins composed of block, graft, and bimodal copolymers³¹ to allow dual properties. These lead to both mechanical rigidity and rubbery, shock-absorbing properties that are necessary to maintain a hairstyle without making the hair too sticky. Control of molecular weight allows the fixative to be “tuned” to display exact mechanical

properties. Moreover, if the copolymer is comprised of at least one hydrophilic segment and one hydrophobic segment, it forms films that enhance interfiber attractive forces, exhibit the desired resistance to humidity, but are soluble in shampoo.

Hair sprays, also known as lacquer or spritz, are aerosol solutions of film-forming resins designed to hold a finished hairstyle. In the United States the aerosol hair spray industry has been driven to develop low volatile organic compound (VOC) systems to comply with the Clean Air Act³² and California EPA Air Resources Board restrictions.³³ VOCs have a high vapor pressure at room temperature and easily evaporate into the environment. They are implicated in sensory irritation. In most cases this has meant the development of “aqueous” systems in which a significant portion of an organic solvent is replaced by water.

Mousses are complex formulations with resins, surfactants, and oils in a propellant system. A lighter-weight hair styling product, these are often used on frizzy hair to improve wet manageability and improve body and style retention. Color mousse is used to cover up gray hair and to create a hairstyle at the same time. Semi-permanent color mousse can be used to give toning to hair that is fading from hair color processes.

Setting lotions, applied to damp hair prior to putting in curlers, are used to improve the hair’s ability to accept and maintain a curl. Styling and sculpturing lotions and gels are film-forming resins in a lotion or gel delivery system. Used to stiffen hair into a particular hairstyle, these can add moderate or extreme hold.

Pomades contain petroleum derivatives and waxes to make hair look slick and shiny. These prevent the hair from drying out and may require several washes or a special shampoo to remove. Serums form a thin protective layer on the hair strands. These are primarily composed of oils, hyaluronic acids, ceramides, and silicones. Used for dry, frizzy, or chemically treated hair, these are applied prior to drying to protect the hair as well as enhance shine and combability. Waxes are thick hairstyling products containing beeswax, oils, perfumes, and/or coloring agents. These assist with “hold” but allow the hair to remain pliable.

“Natural” Products

The modern consumer is attracted to “natural” hair care products due to an often mistaken belief in the benefit, safety, and lack of toxicity of natural or organic products.³⁴ The future of natural hair care products is guided by the requirements of the major “natural” certifying groups and retailers. The natural materials that may be considered include beeswax, albumin, shellac excreted by the female lac bug, aloe vera gel, acacia Senegal gum, and natural polymers like protein hydrosylates, chitosan, and castor and jojoba oils.³⁵

Available plant derived substances include argan oil, panthenol, chamomile, West Indian Bay oil, coconut oil, rosemary, sage, thyme, garlic, and tea tree oil. Although few clinical studies have been performed to support the use of these in hair products, some have been studied and can improve the physical and cosmetic properties of hair. Meinert et al. showed that application of white tea extract and provitamin A to hair followed by exposure to UV plus visible light improves tensile strength. White tea extract also led to less lightening of non dyed hair.³⁶

In another study, a rinse-off hair mask was evaluated. A rinse-off mask with 1% cotton honeydew extract containing fructose, glucose, inositol, melezitose, saccharose, and trehalosein was effective in softening the hair surface by “smoothing the cuticle cells” compared to a placebo rinse-off mask.³⁷

Coconut oil and tea tree oil are two hair care products used by consumers for hair care. When used as a pre-wash and post-wash grooming product, coconut oil has been found to reduce the protein loss associated with shampooing for both undamaged and damaged hair. Coconut oil, being a triglyceride of lauric acid, has a high affinity for hair proteins and, because of its low molecular weight and straight linear chain, is able to penetrate inside the hair shaft.³⁸ *Melaleuca altrenifolia* (tea tree) products have been highly touted as antiseptic and antimicrobial agents. Satchell et al. studied a 5% tea tree oil shampoo and found it to be effective in the reduction of itching compared to a placebo for subjects with seborrheic dermatitis.³⁹

Recent Advances in Hair-Care Products

Hair science research is driven by the multibillion dollar hair care market, the search for more effective products, consumer desire for natural products, and regulations imposed to improve safety. Advances in conditioners include the use of new non-cationic conditioning polymers with improved conditioning properties and the ability to co-exist in an anionic environment,⁴⁰ in chemical straightening systems designed for Afro-ethnic hair,⁴¹ and with improved delivery of silicones and other performance ingredients⁴² to the hair. Novel keratin proteins and peptides derived from wool have been described,⁴³ and effective technologies for deposition of 18-methyleicosanoic acid onto the surface of alkaline treated hair are being developed.⁴⁴ Furthermore, strategies to improve the use of silicone oils in hair care products are evolving. Techniques to improve adsorption of silicon onto the surface of the hair fiber,⁴⁵ as well as the use of silicon oil-in-water nanoemulsions,⁴⁶ show promise. Additional trends include conditioners that decrease fading of colored hair⁴⁷ and strategies to improve the deposition of sunscreens onto hair.⁴⁸

There are new advances in hair restorative products. Human eye γ D-crystallins are promising strengthening agents for the development of restorative hair care products. Chosen based on the ability of proteins of this superfamily to be involved in “coating specific structures,” crystallins have been shown to bind and penetrate the hair fiber to improve its mechanical properties even when compared to virgin hair.⁴⁹ Ceramides have been used to treat damaged hair. Application of ceramide-rich liposomes derived from internal wool lipids (IWL) has been demonstrated to restore the lipid composition and resistance to the breaking of chemically-treated hair fibers.⁵⁰ Application of trehalose is a new way to provide a long-lasting straight style to heat styled hair, despite humid conditions. Trehalose is a natural disaccharide that can be synthesized by bacteria, fungi, plants, and invertebrate animals, and is implicated in the ability to withstand prolonged periods of desiccation.⁵¹

Products traditionally used to rejuvenate skin are being studied for hair care benefit. Treatment with glycolic acid has been shown to raise the temperature required to denature the hair by 10°C and decreased fiber stiffness on tensile testing. Radiolabeling studies demonstrate the penetration of glycolic acid inside the hair fiber.⁵² Fixative polymers with longer lasting style can be achieved by use of newly improved block co-polymers. These allow for the long-term styling of hair with the option of changing the shape at the desire of the consumer.⁵³

Selvan et al. have reported that “immunocosmeceuticals” are an emerging trend in reparative hair care products. They describe immunizing laying hens with damaged human hair extract to produce anti-hair antibodies that can be extracted from egg yolk. These yolk-derived antibodies bind to damaged hair leading to “prevention and restoration of split ends” and “conditioning effects.” The changes were found to persist despite repeated shampooing.⁵⁴

Conclusion

The future is bright for hair care. Academic diligence, the multibillion dollar market for hair care products, and the desire for products with improved qualities have driven hair care science to a unique level of sophistication. Many exciting developments in natural, synthetic, and biologically-derived polymer science, unique cosmeceuticals, and nanotechnology promise that the next decade will produce products that exceed all expectations.

REFERENCES

1. Schueller R, Romanowski P. *Beginning Cosmetic Chemistry*. Carol Stream, IL: Allured Publishing Corporation; 2009.
2. Robbins CR. *Chemical and Physical Behavior of Human Hair*. Berlin Heidelberg: Springer-Verlag; 2012.
3. Clausen T, Schwan-Jonczyk A, Lang G et al. Hair Preparations. In *Ullmann's Encyclopedia of Industrial Chemistry*. Weinheim, Germany: Wiley-VCH; 2006, pp. 1–46.
4. Draelos ZD. Essentials of hair care often neglected: Hair cleansing. *Int J Trichology* 2010;2:24–9.

5. Trüeb RM. Shampoos: Ingredients, efficacy and adverse effects. *J Dtsch Dermatol Ges* 2007;5(5):356–65.
6. Evans T, Randall Wickett R. *Practical Modern Hair Science*. Carol Stream, IL: Allured Books; 2012.
7. Goddard ED, Gruber JV. *Principles of Polymer Science and Technology in Cosmetics and Personal Care*. New York: Marcel Dekker; 1999.
8. https://www.makingcosmetics.com/Articles-Reports_ep_45.html (accessed on June 7, 2015).
9. Williamson D, Gonzalez M, Finlay AY. The effect of hair loss on quality of life. *J Eur Acad Dermatol Venereol* 2001;15(2):137–9.
10. Gray J. *Icss 266, Assessment of Hair Quality Using Eye Tracking Technology (International Congress and Symposium Series)*. London: Royal Society of Medicine Press; 2007.
11. Zhuang XS, Zheng YY, Xu JJ et al. Quality of life in women with female pattern hair loss and the impact of topical minoxidil treatment on quality of life in these patients. *Exp Ther Med* 2013;6(2):542–6.
12. Benfer RA, Typpo JT, Graf VB et al. Mineral analysis of ancient Peruvian hair. *Am J Phys Anthropol* 1978;48(3):277–82.
13. Taru P, Backwell L. Identification of fossil hairs in *Parahyaena brunnea* coprolites from Middle Pleistocene deposits at Gladysvale cave. *South Africa J Archaeolog Sci* 2013;40:3674–3685.
14. Bhushan B. *Biophysics of Human Hair: Structural, Nanomechanical and Nanotribological Studies*. Heidelberg: Springer; 2010.
15. Popescu C, Höcker H. Hair—the most sophisticated biological composite material. *Chem Soc Rev* 2007;36(8):1282–91.
16. Ito S, Wakamatsu K. Diversity of human hair pigmentation as studied by chemical analysis of eumelanin and pheomelanin. *J Eur Acad Dermatol Venereol* 2011;25(12):1369–80.
17. Yu J, Yu DW, Checkla DM et al. Human hair keratins. *J Investigative Dermatol* 1993;101:56S–59S.
18. Feughelman M. The physical properties of alpha keratin fibers. *J Soc Cosmet Chem* 1982;33:385–406.
19. Wang L, Chen L, Han L et al. Kinetics and equilibrium of solute diffusion into human hair. *Ann Biomed Eng* 2012;40(12):2719–26.
20. Wilkerson V. The chemistry of human epidermis. *J Biol Chem* 1935;112(1):329–35.
21. Franbourg A, Hallegot P, Baltenneck F et al. Current research on ethnic hair. *J Am Acad Dermatol* 2003;48(6 Suppl):S115–9.
22. Cheng AS, Bayliss SJ. The genetics of hair shaft disorders. *J Am Acad Dermatol* 2008;59(1):1–22.
23. Swanbeck G, Nyren J, Juhlin L. Mechanical properties of hair from patients with different types of hair diseases. *J Invest Dermatol* 1970;54(64):248–51.
24. Korastoff A. Normalized stress strain relationship in human hair by perturbation by hypothyroidism. *Br J Dermatol* 1970;83:27–36.
25. Lindelöf B, Forslind B, Hedblad MA et al. Racial characteristics of hair. In Saferstein RE, ed. *Forensic Science Handbook*. Englewood Cliffs, NJ: Prentice Hall; 2002.
26. Khumalo NP. Yes, let's abandon race—it does not accurately correlate with hair form. *J Am Acad Dermatol* 2007;56(4):709.
27. Mettrie R, Saint-Léger D, Loussouarn G et al. Shape variability and classification of human hair: A worldwide approach. *Human Biol* 2007;79.3:265–81.
28. Loussouarn G, Garcel AL, Lozano I et al. Worldwide diversity of hair curliness: A new method of assessment. *Int J Dermatol* 2007;46(Suppl 1):2–6.
29. Gao T, Bedell A. Ultraviolet damage on natural gray hair and its photoprotection. *J Cosmet Sci* 2001;52(2):103–18.
30. Katugampola RP, Statham BN. A review of allergens found in current hair-care products. *Contact Dermatitis* 2005;53(4):234–5.
31. <http://www.interpolymer.com/stuff/contentmgr/files/0a4a1a8bf323375ba8b94ef2d01da7e8/miscdocs/Paper%20Bimodal.pdf> (accessed on June 15, 2015).
32. http://www.epa.gov/air/caa/caaa_overview.html (accessed on June 15, 2015).
33. <http://www.arb.ca.gov/consprod/regs/regs.htm> (accessed on June 15, 2015).
34. Harrison S, Bergfeld W, Andersen F. Cosmeceuticals for hair and nails. In Sadick NS, Lupo M, Berson DS, eds. *Cosmeceutical Science in Clinical Practice*. Boca Raton, FL: CRC Press; 2010, pp.63–74.
35. <http://www.cosmeticsandtoilettries.com/formulating/category/natural/premium-Formulating-Natural-Hair-Care-211557591.html> (accessed on June 15, 2015).
36. Meinert K, Springob C, Schmidt CU et al. Influence of antioxidants on the sun protection properties of hair care products. *J Cosmet Sci* 2004;55(Suppl):S105–12.

37. Oberto G, Bauza E, Berghi A et al. Cotton honeydew (*Gossypium hirsutum* L.) extract offers very interesting properties for hair cosmetics and care products. *Drugs Exp Clin Res* 2005;31(4):131–40.
38. Rele AS, Mohile RB. Effect of mineral oil, sunflower oil, and coconut oil on prevention of hair damage. *J Cosmet Sci* 2003;54(2):175–92.
39. Satchell AC, Saurajen A, Bell C et al. Treatment of dandruff with 5% tea tree oil shampoo. *J Am Acad Dermatol* 2002;47(6):852–5.
40. Hössel P, Dieing R, Nörenberg R et al. Conditioning polymers in today's shampoo formulations—Efficacy, mechanism and test methods. *Int J Cosmet Sci* 2000;22(1):1–10.
41. Dias TC, Baby AR, Kaneko TM et al. Protective effect of conditioning agents on Afro-ethnic hair chemically treated with thioglycolate-based straightening emulsion. *J Cosmet Dermatol* 2008;7(2):120–6.
42. Drovetskaya TV, Diantonio EF, Kreeger RL et al. New high-charge density hydrophobically modified cationic HEC polymers for improved co-deposition of benefit agents and serious conditioning for problem hair. *J Cosmet Sci* 2007;58(4):421–34.
43. Roddick-Lanzilotta A, Kelly R, Scott S et al. New keratin isolates: Actives for natural hair protection. *J Cosmet Sci* 2007;58(4):405–11.
44. Tanamachi H, Inoue S, Tanji N et al. Deposition of 18-MEA onto alkaline-color-treated weathered hair to form a persistent hydrophobicity. *J Cosmet Sci* 2009;60:31–44.
45. Nazir H, Lv P, Wang L et al. Uniform-sized silicone oil microemulsions: Preparation, investigation of stability and deposition on hair surface. *J Colloid Interface Sci* 2011;364(1):56–64.
46. Hu Z, Liao M, Chen Y et al. A novel preparation method for silicone oil nanoemulsions and its application for coating hair with silicone. *Int J Nanomedicine* 2012;7:5719–24.
47. Kulcsar L. Hair Care Compositions, U.S. Patent Application 20120201777, August 9, 2012.
48. Bitler SP. U.S. Patent 7,101,928, September 5, 2006.
49. Ribeiro A, Matamá T, Cruz CF et al. Potential of human γ D-crystallin for hair damage repair: Insights into the mechanical properties and biocompatibility. *Int J Cosmet Sci*. 2013;35(5):458–66.
50. Méndez S, Manich AM, Martí M et al. Damaged hair retrieval with ceramide-rich liposomes. *J Cosmet Sci* 2011;62(6):565–77.
51. Pye S, Paul PK. Trehalose in hair care: Heat styling benefits at high humidity. *J Cosmet Sci* 2012;63(4):233–41.
52. <http://www.cosmeticsandtoiletries.com/formulating/category/haircare/Glycolic-Acid-No-Longer-Just-for-SkinChanging-the-Internal-Properties-of-Hairpremium-230214331.html?c=n#sthash.HVbEsfhV.dpuf> (accessed on June 15, 2015).
53. Vic G, Brun G, Gourlaouen L. Process for treating hair fibers using polysiloxane/urea, U.S. Patent Application 20120192887-A1, 2012.
54. Selvan K, Rajan S, Suganya T et al. Immunocosmeceuticals: An emerging trend in repairing human hair damage. *Chron Young Sci* 2013;4:81–5.

19

Moisturizers: Treatment of Dry Skin Syndrome and Barrier Defects

Marie Lodén

Introduction

Dry and chapped skin is a common problem both in healthy individuals and in patients with skin diseases. The problem can occur in response to an environment with low humidity and/or low temperature. Behavior may also contribute to the dryness, where exposure to solvents, cutting fluids, surfactants, acids, and alkalis may produce dry skin. Moreover, dry skin might be connected to some inherited disorders relating to the structure and function of the epidermis, for example ichthyosis and atopic dermatitis (AD), and may be secondary to other diseases, for example, diabetes or renal failure.

The medical term for abnormally dry skin is xerosis cutis. This name comes from the Greek word “xero,” which means dry. There are several features that give an impression of dry skin (Table 19.1).¹⁻⁴ The affected person and the dermatologist can judge visible and tactile characteristics of the skin surface, while the affected person also can perceive sensory feelings of dryness. Furthermore, instruments can be used to analyze changes in the chemistry and function of the skin. The most important change of dry skin is the weakened permeability barrier function, as this barrier defect is suggested to drive disease activity in inflammatory dermatoses, such as AD.⁵

Moisturizers or emollients are products used for prevention and treatment of dry skin syndrome. They are able to break the dry skin cycle and maintain the smoothness of the skin. Some products also restore or prevent a defect barrier function. The term “emollient” implies (from the Latin derivation) a material designed to soften the skin, that is, a material that “smooths” the surface to the touch and makes it look smoother to the eye. The term “moisturizer” is often used synonymously with emollient, but moisturizers usually contain humectants, aimed at potentiate hydration of the stratum corneum (SC).

Moisturizers may also contain other ingredients than humectants to improve the dry skin condition, along with ingredients conventionally considered as excipients (for example, emulsifiers, antioxidants, preservatives). Ingredients may be identical to those found in the SC. For example, the natural moisturizing factors (e.g., urea, lactic acid, pyrrolidone carboxylic acid, amino acids) and lipids (e.g., fatty acids and ceramides) are components of the SC which also can be found in moisturizers. Their role in moisturizers can be to replenish substances identified as low in xerotic skin. For example, the content of urea⁶ and ceramides^{7,8} are reduced in dry SC of patients with AD. Furthermore, dry SC samples from old people have an altered amino acid composition.^{9,10} A reduced content of amino acids is also found in patients with ichthyosis vulgaris.¹⁰

The majority of moisturizing creams on the market are regulated as cosmetics, but they may also be classified as pharmaceuticals (equivalent to medicinal products) or as medical devices. When they are regulated as pharmaceuticals or medical devices they can also be marketed for treatment or prevention of diseases, such as AD, psoriasis, ichthyosis, and other hyperkeratotic skin diseases.¹¹ During recent years there has been an increase in formulations certified as medical devices for the treatment of skin diseases.¹²

Finding the most suitable moisturizer for the individual patient is currently a matter of trial and error, since several moisturizers also are reported to induce dryness and make skin *more* susceptible to environmental stimuli instead of making the skin *less* susceptible to dryness.¹³⁻¹⁵ The present chapter will give

TABLE 19.1

Characteristics of “Dry” Skin

Evaluation	Common Findings
Visual	Redness, a lackluster surface, dry white patches, flaky appearance, cracks, and even fissures
Tactile	Rough and uneven surface
Sensory	Feels dry, uncomfortable, painful, itchy, stinging, and tingling sensation
Chemical	Reduced water content, reduced content of natural moisturizing factor (NMF), changed lipid composition
Functional	Impaired skin barrier function, changed frictional resistance
Morphological	Increased stratum corneum thickness, reduced projected size of corneocytes

an overview of the influence of moisturizing treatment on the structure and barrier function of dry skin. Particular emphasis will be given to treatment of hyperkeratosis, xerosis in foot, infant skin, and AD.

Composition of Moisturizers

The most common types of delivery system for emollients and moisturizers are creams, that is, an emulsion. Creams contain two phases, usually oil and water, producing either an oil-in-water (O/W) or a water-in-oil (W/O) emulsion. The droplet size is often between 1 μm and 100 μm . Emulsifiers are added to the formulation to provide stability and desired rheological properties. Emulsifiers have one non-polar hydrocarbon end and one polar end, that is, they combine both hydrophilic and lipophilic components in one molecule, whereby they collect at the interface of the two phases and promote emulsification.

Ointments are a single-phase system, where hydrophobic ointments are preparations that are not miscible with water. When large amounts of finely dispersed solids are incorporated in ointments they are called pastes (e.g., zinc pastes). Gels are hydrophilic or hydrophobic liquids that are gelled by means of suitable gelling agents.

Fats, Oils, and Emulsifiers

Topical formulation terminology does not always have distinct definitions of the words oils, fats, and lipids. Oils (liquid) and fats (solid) are typically mixtures of triglycerides bulk storage material produced by plants and animals. Lipids can be defined as substances biochemically or functionally related to fatty acids. Oils and fats may be classified into animal, vegetable, and mineral types. Common fatty material in moisturizers are mono-, di-, and triglycerides, fatty acids, lanolin, waxes, long-chain esters, and mineral oils. Mineral oils and silicon oils are other types of semisolid materials with oily properties. Silicons originate from silica found in sand, quartz, and granites. The properties of silicons are derived from their molecular structure in addition to the characteristics of the potential organic group joined to the silica.

The chemical structure of triglycerides consists of a glycerol fragment, esterified with fatty acids. There is a large variety in fatty acids, with the saturated fatty stearic acid, the monounsaturated oleic acid, and the polyunsaturated linoleic acid being the most abundant fatty acids. The fatty acid profile, which is typical for certain oils, determines to a great extent the characteristics of an oil with respect to stability, skin feel, and effects on the skin. The most important feature of a fatty acid is the number of double bonds and their distribution over the carbon chain. The degree of unsaturation has a large effect on the ease of handling. Fatty acids with a higher degree of unsaturation are oxidized more easily. Oxidation is increased by the presence of metals, heat, light, and oxygen.

Oils from vegetables and fish may also contain essential fatty acids (EFA). The essential fatty acids influence skin physiology via their effects on the skin barrier function, eicosanoid production, membrane fluidity, and cell signaling.¹⁶ EFA are found mainly within the epidermal phospholipids, but are also incorporated in ceramides where they play a critical role in barrier function. Fatty acids with the first double bond at the 6th C atom counting from the end of the carbon tail is called omega-6, whereas those with the first double bond at the 3rd C atom are called omega-3 fatty acids. Omega-6 and omega-3 fatty

acids are derived from linoleic and α -linoleic acid, respectively. The most abundant EFA in the skin is linoleic acid and its metabolite arachidonic acid. Evening primrose oil and borage oil have gamma-linolenic acid (GLA) levels over 9% and 20%, respectively. Seafood is known to contain omega-3 fatty acids, like eicosapentaenoic (EPA), docosahexaenoic, and stearidonic acid.

Emulsifiers can be classified as ionics (anionic or cationic) or nonionics. Long-chain fatty acids are one group of commonly used anionic emulsifiers, for example, stearic acid and palmitic acid. Fatty acids with a chain length of 14–22 carbons are found in the epidermal tissue. Cholesterol is another component of the lipid bilayer, which also is used as a nonionic emulsifier in moisturizers. Nonionic emulsifiers depend chiefly upon hydroxyl groups and ether linkages to create the hydrophilic action.

Lanolin is an animal type of wax (from the Latin *lana* for wool and *oleum* for oil) secreted by the sebaceous glands of the sheep. Lanolin is a complex mixture of esters, disesters, and hydroxy esters of high molecular weight lanolin alcohols and lanolin acids. Unlike human sebum lanolin contains no triglycerides. Beeswax is a complicated mixture of hydrocarbons, esters, and fatty acids. A typical example of a vegetable-derived wax is carnauba, which is obtained from the leaves of the carnauba palm tree.

Mineral oils are derived from petroleum and the most important materials are liquid paraffin (paraffinum liquidum), solid paraffin, and petrolatum (vaseline). The materials used for topical products are highly purified and consist of complex combinations of oxidation-resistant hydrocarbons. Depending on the distribution of the molecular weight, materials with different viscosity are obtained. Petrolatum was included already in the 1880 edition of the U.S. Pharmacopeia.¹⁷ Still today, mineral oil is used as one of the main components of moisturizers. The physical effects on the SC is simply through its mechanism of hydrating and occluding the SC from which many biological benefits are derived.¹⁸

Effects of Fats and Oils Applied to the Skin

Application of fatty material to the skin surface may increase skin hydration by several mechanisms. The most conventional one is occlusion, which implies a simple reduction of the loss of water from the outside of the skin. Common occlusive substances in moisturizers are petrolatum, beeswax, lanolin, and various oils.¹⁹ These materials have long been considered to exert their effects on the skin solely by forming an inert, epicutaneous, occlusive membrane.¹⁸

The degree of suppression of transepidermal water loss (TEWL) from application of formulations depends on the amount of product applied, the content and types of fatty materials in the formulation. A thick layer (3 mg/cm²) of pure petrolatum would give a similar reduction of TEWL²⁰ as a semi-occlusive silicone membrane.²¹ A ten times thicker layer of petrolatum (30 mg/cm²) on excised skin induces swelling of the corneocytes located centrally in the SC after 24 h.²² Application of structural lipids from SC also increases skin hydration and reduces scaling.^{23,24} Topically applied lipids may also penetrate the skin.^{25–30} Clinical interesting differences between the impact of olive oil and sunflower oil on SC was recently reported, where treatment with olive oil for four weeks caused a significant reduction in SC integrity and induced mild erythema in volunteers with and without a history of AD, whereas sunflower seed oil preserved SC integrity and did not cause erythema in the same volunteers.³¹ Olive oil was suggested to be able to exacerbate existing AD.³¹

Lipids have also been suggested to influence the cutaneous inflammation. Polyunsaturated fatty acids in oils could potentially be transformed enzymatically by the epidermis into “putative” anti-inflammatory products.³² Small hydrophobic compounds, such as free fatty acids and certain oxysterols, are recognized by nuclear hormone receptors, the largest family of transcription factors. Activation of certain receptors regulates keratinocyte proliferation and differentiation. For example, peroxisome proliferating activated receptor (PPAR α) has been found involved in the oxidation of long chain fatty acids.³³ Cutaneous inflammation as it occurs in contact irritant contact dermatitis was reduced by the PPAR α -agonist linoleic acid in mice.³⁴ Moreover, activators of liver X receptors display anti-inflammatory activity in both irritant and allergic models of dermatitis.³⁵ Studies have also demonstrated that such activators stimulate epidermal differentiation and improve permeability homeostasis.³⁶

Linoleic acid is an abundant fatty acid in vegetable oils. Clinical studies suggest that oral or topical supplements of eicosapentaenoic acid (EPA) and/or omega-3 derivatives can decrease the severity of psoriasis.^{28,37} However, oral treatment and topical treatment in randomized and double blind studies

could not support the effect on moderate psoriasis.^{38,39} Topical treatment with sunflower seed oil (rich in linoleic acid) did not improve the disease or change TEWL, but increased the level of linoleic acid in the epidermal phospholipids.⁴⁰

A range of dietary oil supplements has also been suggested to be effective for treatment of AD. Some studies have also shown promising effects of evening primrose oil, a vegetable oil rich in gamma-linolenic acid (GLA), when administered orally to atopic patients.⁴¹ However, this has not been confirmed in more recent double blind and placebo controlled studies, neither on children⁴² nor on adult patients.^{43,44}

Humectants and Water

The majority of the water attracting humectants in moisturizers are low molecular weight substances. Humectants differ in water binding capacity (Table 19.2) as well as in their ability to penetrate and influence the degree of skin hydration.

One important group of humectants is the α -hydroxy acids (AHA), for example lactic acid, glycolic acid, and tartaric acid. Formulations containing an AHA have an acidic pH in the absence of any inorganic alkali or organic base. Lactic acid has been used in topical preparations for several decades because of its buffering properties and water binding capacity.⁴⁷

Urea and pyrrolidone carboxylic acid (PCA, also pidolic acid) are other physiological substances used in moisturizers. Urea occurs in human tissues, blood, and urine. Urea is used for the treatment of ichthyosis and hyperkeratotic skin disorders.^{17,47} The sodium salt of PCA is a naturally occurring humectant in the SC corresponding to approximately 2% by weight in the SC.⁴⁸

Glycerin and propylene glycol are also important humectants in skin care products. Propylene glycol is also used as a solvent, penetration enhancer, and as a vehicle for substances unstable or insoluble in water.

Hyaluronic acid is a member of the class of amino-sugars containing polysaccharides known as the glycosaminoglycans. The polymer is widely distributed in body tissues and provides the turgor for the vitreous humor of the eye and functions also as a lubricant between the collagen and the elastic fiber networks in dermis. The name hyaluronic acid derives from the Greek *hyalos* (glossy, vitreous) and uronic acid. Molecular weight is within the range of 50,000– 8×10^6 depending on source and methods of preparation.⁴⁹

Effects of Water and Humectants on the Skin

Water in the applied moisturizers diffuses into the skin and has an immediate hydrating effect of the SC.¹⁹ Prolonged exposure to water induces swelling of the corneocytes in the thickness dimension of SC.⁵⁰ In the intercellular lamellar regions, rough structures, water pools, and occasionally vesicle-like structures can be observed.⁵¹ Humectants in moisturizers are also supposed to penetrate into the skin and increase the degree of hydration. Swelling of corneocytes is noted after treatment with humectants, such as glycerin.²² The water-holding capacity of normal SC and of scales from psoriatic and ichthyotic patients is increased after treatment with urea and glycerin.^{52–55} The amount of water held by the solvent-damaged guinea pig footpad corneum increases in the following order: sorbitol < glycerin < sodium lactate < sodium PCA.⁵⁶

Water as well as the humectants in themselves maintain skin suppleness and plasticity.^{56–60} If NMF is removed from the SC, water alone cannot restore elasticity.⁶⁰ Humectants might also influence the

TABLE 19.2

Moisture Binding Ability of Humectants at 58%–60% Humidities

Humectant	%
Glycerin	35–38 ^{45,46}
Na-lactate	66 ⁴⁶
Na-pyrrolidone carboxylic acid (PCA)	61–63 ^{45,46}
PCA	<1 ⁴⁵
Propylene glycol	32 ⁴⁶
Sorbitol	10 ⁴⁶

Note: Description of test conditions can be found in the original articles.

crystalline arrangement of the bilayer lipids.⁶¹ Ingredients in moisturizers may help to maintain the lipids in a liquid crystalline state at low relative humidity.^{61,62} Glycerin has been found to modulate the phase behavior of SC lipids *in vitro* and prevent crystallization of the lamellar structures at low relative humidity.⁶² Glycerin has also been suggested to ameliorate dry flaky skin by facilitating the digestion of the superficial desmosomes in subjects with dry skin.⁶³ Glycerin appears to act synergistically with lipids and to reduce xerosis more rapidly than expected from studies on skin dryness.⁶⁴

The humectant urea has also been suggested to protect against osmotic stress and retain the liquid crystalline phase of the lipids at lower relative humidity.⁶⁵ Urea is also reported to be a regulator of the epidermal permeability barrier function, with potential therapeutic applications in skin diseases.⁶⁶ Topical application of urea improves the barrier function in parallel with enhanced antimicrobial peptide (AMP; LL-37 and b-defensin-2) expression.⁶⁶ Urea stimulates the keratinocytes by two urea transporters and by aquaporins. Inhibitors of these urea-transporters blocks the downstream biological effects of urea, which include increased mRNA and protein levels of (i) transglutaminase-1, involucrin, loricrin, and filaggrin, (ii) epidermal lipid synthetic enzymes, and (iii) cathelicidin/LL-37 and b-defensin-2. A recent study also found that urea affects cutaneous arterial sympathetic nerve activity and elevates blood flow via histaminergic H3-receptor.⁶⁷

The polymer hyaluronic acid can hold water so tightly that it can be picked up as though it was a gel.⁶⁸ High molecular weight hyaluronic acid solutions form hydrated viscoelastic films on the skin.⁶⁸ The larger the molecular size, the greater the aggregation and entanglement of the molecules.⁶⁸ Owing to the high molecular weight, hyaluronic acid will not penetrate deeper than the crevices between the desquamating cells. The polymer may be injected to obtain a smoother surface and reduce the depth of wrinkles.

Preservatives and Antioxidants

The entire composition of the moisturizer is believed to be important for the outcome of the moisturizer-treatment, that is, ingredients supposed to constitute the vehicle may also contribute to the effect on the skin. For example, preservatives may be positive or negative to the skin not only due to risks for adverse skin reactions to the preservatives, but also due to potential influences of the preservatives on skin microflora. Preservatives are used in moisturizing creams to kill or inhibit the growth of microorganisms inadvertently introduced to the cream during manufacturing or use. Badly preserved moisturizers allow contamination and growth of microorganisms in the products.⁶⁹ For example, contamination with *Staphylococcus aureus*⁶⁹ is reported, probably due to high densities of this microorganism on the skin surface of patients with AD and eczema. The presence of certain microorganisms on the surface has been linked to inflammation, as microorganisms may release, for example, exotoxins, superantigens, and enzymes which can break down the barrier. Antiseptic and antibiotic treatments are therefore successfully used in certain AD patients colonized with, for example, *Staphylococcus aureus*.⁷⁰ Consequently, application of moisturizers to the skin may affect skin microflora and the likelihood of developing eczema. Not only the use of contaminated moisturizers may induce relapse of eczema, but also the influence of ingredients on the “normal” skin microflora may be important for the risks for eczema. Furthermore, ingredients in moisturizers may change the first line of defense in the skin by up- or down-regulation of antimicrobial peptides, as these are key elements in the innate immune response.⁷¹

The selection of individual preservatives, pH-value, and other ingredients in the formulation determine the microbiological resistance of the preservative system of the product. Certain substances, such as ethanol and propylene glycol, may enhance the effect of the preservatives. In addition, alcohols may on their own prevent contamination of the product when they are used at high concentrations. Propylene glycol is used as an inhibitor of fermentation and mold growth.

Tocopherols, butylated hydroxytoluene (BHT), and alkyl gallates are included in moisturizers to inhibit oxidation by reacting with free radicals blocking the chain reaction.¹⁷ Reducing agents, such as ascorbic acid, may also act by reacting with free radicals, as well as oxidize more readily than the ingredients they are intended to protect. Citric acid, tartaric acid, and EDTA and its salts have minor antioxidant activity, but enhance the antioxidant activity by “removing” heavy-metal ions. Such substances are called chelating agents.¹⁷ The stability of the metal-EDTA complex depends on the metal ion involved and on the pH. The calcium chelate is relatively weak and EDTA will preferentially chelate heavy metals,

such as iron, copper, and lead.¹⁷ Divalent ions such as calcium regulate the cell dissociation and EDTA appears to increase the rate of cell dissociation *ex vivo*.⁷²

Application of Moisturizers

The combination of ingredients in moisturizers is crucial for the stability of the formulation, the cosmetic properties, and the influence of the formulation on the skin. The ingredients influence the initial feel of the product, its spreading behavior on the skin, whether and how fast it is absorbed, and how the skin feels after its use. Smoothing of the skin surface is observed immediately after application as a result of the filling of spaces between partially desquamated skin flakes.^{73,74} Application of moisturizers to the skin also changes surface friction⁷⁵ and skin topography.^{52,76–79}

Substances applied to the skin can remain on the surface for a while, be absorbed into the skin, be metabolized or disappear from the surface by evaporation, sloughing off or by contact with other materials. After eight hours, 50% of applied cream has been reported to remain on the surface.⁸⁰ Creams and ointments seem to allow higher transfer of the actives to surrounding surfaces than lotions and tinctures.⁸¹ The type of vehicle may also influence the distribution within the treated area.⁸² A thick ointment with only a few percent of water has been found to be equally distributed in the center and periphery of the treated area, whereas formulations with lower viscosity and more volatile ingredients (e.g., creams) were less evenly spread on the skin.⁸²

The cosmetic properties and the presentation of the product influence the usage.⁸³ Greasy and sticky properties can be a nuisance and the smell of some products can be difficult to accept. Low compliance can therefore be a problem with topical treatments of diseases and the process of treating the skin can often itself add to the burden of having the disease. The patients can also receive conflicting treatment advice, leading to frustration, non-compliance, and difficulty in following an effective regimen.⁸⁴

Differences in dosing are noted among self-application versus operator assisted application of creams, where self-application resulted in a larger amount applied per unit area.^{85,86} Moreover, jars promoted the use of larger quantities than the same cream in a tube (1.7 vs. 0.7 mg/cm², respectively).⁸⁶ The properties of the moisturizer depends on the ratio between oil and water, as well as on the type of oil and the amount and type of other ingredients (emulsifiers, humectants, etc.).

Moisturizers and Skin Barrier Function

The quality of SC determines the barrier function of the skin. Barrier function can easily be measured as TEWL using commercial instruments or by application of substances to the skin and monitoring the biological response (Table 19.3). Dry and scaly skin is usually associated with a defective barrier

TABLE 19.3

Examples of Substances That Have Been Used to Test the Skin Barrier Function

Substance	Biologic Response
Surfactants	Irritation
Alkali resistance	Burning, itching, erythema
Dimethyl sulfoxide (DMSO)	Urticaria
Nicotinates	Vasodilation
Corticosteroids	Vasoconstriction
Toluene	Irritation

Source: Adapted from Kolbe L. In: Lodén M, Maibach HI, eds. *Dry Skin and Moisturizers: Chemistry and Function*. Boca Raton, FL: CRC Press; 2000, pp. 393–401.

TABLE 19.4**Factors Influencing the Lipid Composition of the Skin**

Anatomical region ¹⁰⁸
Sex ¹⁰⁹
Age ¹⁰⁹
Season ¹¹⁰
Exposure to surfactants ^{100,111}
Exposure to solvents ^{23,24,112,113}
Tape-induced scaly skin ¹¹⁴
Atopic dermatitis ^{7,8,115}
Psoriasis ^{93,116}
Ichthyosis ¹¹⁷

function.^{88–94} This defect can be due to reduced elasticity of the SC layer, giving rise to cracks and fissures in dry skin.^{95,96} In non-cracked skin the major route of penetration is through the intercellular pathway around the corneocytes. This highly convoluted and tortuous lipid pathway gives a longer distance for penetration than the actual thickness of the SC.^{97,98} However, in dry and scaly skin the projected size of the corneocytes can be decreased, which reduces the tortuosity and facilitates penetration.^{98,99} A potential way for SC to compensate for a defect SC barrier function is hyperkeratosis. Hyperkeratosis thus indicates a failure of epidermis to produce a competent barrier with normal thickness, but may also reflect an undesired inhibition of the desquamation process. The dryness can be confined to the outermost layer of SC with a competent permeability barrier present in the lower part of the SC.¹⁰⁰

In addition to the distance of penetration in the SC, the content and organization of the intercellular barrier lipids are critical for the resistance to penetration.^{101–104} The lipid membranes contain primarily cholesterol, free fatty acids, and ceramides organized in lamellar phases. The structural arrangement of the lipid molecules is not clearly elucidated, but studies suggest that the different lipids may segregate in the membrane and form separate fluid and solid phases within the SC.^{105,106} The bulk of the lipids has been suggested to be in crystalline/gel domain bordered by lipids in a fluid crystalline state; a “domain mosaic model.”¹⁰⁷ This model is considered an effective water barrier which allows a controlled loss of water to keep the corneocytes moistened.¹⁰⁷ The lipid composition of the SC is highly variable among individuals and not surprisingly changes in the lipid composition may influence the bilayer structure and barrier function (Table 19.4).^{7,8,23,24,112–117}

Preventing and Restoring Skin Barrier Defects

Permeability barrier abnormalities drive disease activity in inflammatory dermatoses, such as AD.⁵ The composition of the moisturizer determines whether the treatment strengthens or deteriorates the skin barrier function and changes the sensitivity of the skin.^{14,24,118–124} A lipid-rich cream without any humectant showed no significant influence on TEWL in healthy skin, but increased skin susceptibility to SLS-irritation compared to untreated skin.¹⁴ Increased skin reactivity was also found in a long term study using a vasodilating substance as a marker for permeability, where the time to maximum redness was shorter for the cream-treated area compared to the untreated.¹²⁴ In another study healthy skin treated with Aqueous Cream BP obtained a thinner SC and higher TEWL.¹²⁵ These observations called into question the continued use of certain products on the already compromised barrier of eczematous skin.¹²⁵ However, moisturizers are different and applications of urea-containing moisturizers have been found to reduce TEWL and make skin less susceptible to SLS-induced irritation.^{119,126,127} Also nicotinamide (vitamin B3) has received positive scientific attention as a barrier enhancing agent, as the level of barrier lipids increased and TEWL decreased.¹²⁸

In experimental models of dryness, moisturizers usually accelerate normalization of the skin.^{24,118,126,129,130} Petrolatum is absorbed into delipidized skin and promotes barrier recovery to water.¹³¹ Higher percentage of fatty materials in the moisturizers has been suggested to enhance barrier repair.¹¹⁸ However, other studies suggest that it is the ratios of physiological lipids in creams that are important.¹³²

Complete mixtures of ceramide, fatty acid, and cholesterol, or pure cholesterol allowed normal barrier recovery in acetone-treated murine skin, whereas two-component mixtures of fatty acid plus ceramide, cholesterol plus fatty acid, or cholesterol plus ceramide delayed barrier recovery.²⁴ However, in surfactant-damaged human skin no acceleration of barrier recovery was monitored after treatment with ceramide 3B in different emulsions.¹³³ Neither did a moisturizer consisting of ceramide-3, cholesterol, and fatty acids (“skin identical lipids”) in a petrolatum-rich emulsion show superiority to pure petrolatum in human skin, damaged by SLS and tape-strippings.¹³⁴ In tape-stripped aged human skin a lipid mixture with cholesterol as the dominant lipid accelerated barrier recovery.¹³⁵ As ceramides are large molecules, the absorption of ceramides and the superiority of certain lipid mixtures to other mixtures remain to be proven in randomized and controlled studies on humans.^{133,134,136}

Commercially available moisturizers have also been found to reduce elevated TEWL in acetone-treated mice skin compared to untreated areas during a 24-hour test period.¹³⁷ However, not only lipids but also nonionic emulsifiers¹³⁸ and the humectants glycerin¹²⁹ and dexpanthenol¹³⁹ have been reported to influence barrier repair in damaged human skin.

In clinical studies of barrier diseases, the visible symptoms of dryness always improves, but the elevated high TEWL may not become normalized by the treatment. Three different patterns are noted in skin barrier diseases:

1. The elevated TEWL level may remain unchanged.^{122,140}
2. TEWL may increase further (i.e., weakening of the barrier).^{120,121}
3. TEWL decreases towards normal values (i.e., improvement of the barrier).^{54,141}

For example, treatment of ichthyosis with a urea-lactic acid moisturizer (Calmuril) improved skin barrier function,⁵⁴ whereas a lactic-acid propylene glycol moisturizer (Locobase-LPL) further weakened the barrier in ichthyotic patients.¹²¹

Moisturizers in Hyperkeratosis

Ichthyosis

Urea and AHAs, especially glycolic and lactic acid, are found to be beneficial for treatment of hyperkeratotic skin, such as ichthyosis, where the number of SC layers is reduced after treatment with 10% urea in combination with 5% lactic acid.^{53,142,143} Distinct changes in the epidermis are found, which might mediate a prompt influence on the keratinization process. There is an abrupt loss of the entire abnormal SC, probably due to a diminished cellular cohesion between the corneocytes at the lowermost, newly forming levels of the SC, at its junction with the stratum granulosum.^{144,145}

X-linked ichthyosis has also been treated topically with cholesterol and some improvement in the functional and the structural abnormalities was found.^{146,147} In a double-blind study on 60 children it was shown that 10% urea was superior to its placebo in reducing the severity of generalized ichthyosis.¹⁴⁸ Improvement in lamellar ichthyosis was also reported after treatment of one patient with 10% N-acetylcysteine in a moisturizing cream.¹⁴⁹ N-acetylcysteine was found to have an antiproliferative effect on a culture of human keratinocytes.¹⁴⁹ Less scaling, hyperkeratosis, and xerosis were also reported after treatment of patients with lamellar ichthyosis with 5% lactic acid combined with 20% propylene glycol.¹²¹

Foot Xerosis and Cracked Heel

Clinical benefit is also reported from the use of topical preparations in the treatment of foot xerosis and cracked heels (Table 19.5). The improvements are reported to be significant when compared to an untreated control foot or when compared to the degree of xerosis at baseline (start of treatment). Reduced thickness of the hyperkeratotic skin is also reported.¹¹⁵ Studies have also tried to elucidate the benefit with the addition of various active ingredients, such as humectants. For example, a cream containing 10% urea and 4% lactic acid provided faster and better improvement compared to its vehicle in diabetic

TABLE 19.5

A Summary of Clinical Studies on the Treatment of Xerosis on the Feet with Topical Formulations

Design (Number of Volunteers Included/ Analyzed)	Test Products (Ingredients)	Study Period, Application	Outcomes
Single blind, bilateral, controlled (50/50)	Footmender; 15% alfahydroxy acids and 15% urea	Once- and twice-daily, 2 weeks	Increased hydration, less hyperkeratosis and scaling, without weakening of the skin barrier function, once-daily equally effective as twice-daily ¹⁵⁰
Double-blind, bilateral, CCS left foot and BP Aqueous cream on right foot (15/15)	CCS foot care (emulsion with conventional emollients and 13% glycerin, 10% urea and lactic acid) vs. BP aqueous cream (emulsion with conventional emollients, no humectant)	Twice daily, 2 weeks	Both increased hydration, and CCS superior ¹⁵¹
Open (24/24, whereof 10 with diabetes)	10% urea in an emulsion with emollients, no control	Twice daily, 4 weeks	Reduced thickness of the thickened heel during treatment period ¹⁵²
Randomized, double-blind, bilateral (55/54 with type 1 or 2 diabetes)	10% glycerol, 5% urea, 1% lactic acid, 8% paraffin in an emulsion with emollients vs. placebo	Twice daily, 4 weeks	Both feet improved, less dryness/cracks but more effective from active ¹⁵³
Open-label (12/10, whereof 6 with diabetes)	35% urea in a water-lipid-based foam also containing lactic acid	Twice daily, 4 weeks	Significant improvement ¹⁵⁴
Randomized, paired, double-blind (92/51)	12% ammonium lactate vs. pure lanolin	Twice daily, 4 weeks	Both improved, no difference ¹⁵⁵
Randomized, bilateral, double-blind (40/30 with diabetes)	10% urea and 4% lactic acid vs. vehicle	Twice daily, 4 weeks (+2 regression)	Improvement, urea superior ¹⁵⁶
Randomized, double-blind (53/35)	10% lactic acid (Pedinol) vs. 12% ammonium lactate (LacHydrin)	4 weeks	Both groups improved, no significant difference ¹⁵⁷
Randomized, bilateral, double-blind (25/18)	40% urea (Carmol 40) vs. 12% ammonium lactate (LacHydrin)	4 weeks	Both effective. More rapid effect from urea ¹⁵⁸
Randomized, bilateral, double-blind (43/57, whereof 17 with diabetes)	12% ammonium lactate vs. liposome lotion	Twice daily, 4 weeks (+2 regression)	Both improved, no difference ¹⁵⁹
Randomized, paired, double-blind (70/39)	10% urea and 5% salicylic acid vs. 12% ammonium lactate (LacHydrin)	Twice daily, 4 weeks	Both improved, no difference ¹⁶⁰
Randomized, bilateral, evaluator-blind (60/55)	12% ammonium lactate vs. no treatment	Twice daily, 8 weeks (+4 regression)	Improvement from treatment ¹⁶¹
Randomized, double blind, bilateral (8)	10% urea vs. aqueous cream BP	Twice daily, 3 weeks	Improvement, no difference between formulations ¹⁶²

Note: The studies are in publication order with the most recent ones on the top.

TABLE 19.6

Effect of Moisturizers on Dry Skin Conditions Not Linked to Skin Diseases

Condition	Active Substance	Control	Effect on Dryness
Dry skin	3% and 10% urea	Untreated	Improved ¹²⁷
Xerosis	12% ammonium lactate	Petrolatum based cream	Improved, active better ¹⁶³
Xerosis on legs	12% ammonium lactate	5% lactic acid + 2.5% CPA	Improved, active better ¹⁶⁴
Xerosis on legs	12% lactate	5% lactic acid/emollient lotion	All improved, equally effective, but 12% lasted longer ¹⁶⁵
Xerosis	5% lactic acid	Eucerin lotion	Improved, active better ¹⁶⁶
Xerosis	5% PCA	Placebo and 10% urea	Active better than placebo, and equal as urea ¹⁶⁷
Senescent dryness on forearm	10% urea	Placebo	Improved ¹⁶⁸
Asteatosis, senescent dryness on leg	4% urea + 4% sodium chloride	Placebo	Improved, active better ¹⁶⁹

patients with foot xerosis.¹⁵⁶ Also, a mixture of 10% glycerol, 5% urea, 1% lactic acid, and 8% paraffin in an emulsion was superior to its placebo in reducing cracks and dryness.¹⁵³ Furthermore, in a randomized double-blind study of 18 subjects with moderate-to-severe foot xerosis it was found that 28-day treatment with 40% urea (Carmol 40) or 12% ammonium lactate cream (LacHydrin) induced significant improvement,¹⁵⁸ where the improvement was more rapid and pronounced by the urea cream in comparison with the ammonium lactate cream.¹⁵⁸ In another study comparing the 12% ammonium lactate (Lac-Hydrin) with a combination of 5% salicylic acid and 10% urea ointment (Kerasal) the reduction in the severity of mild-to-moderate xerosis was found, but no differences in efficacy was noted between the products.¹⁶⁰ In another study comparing 12% ammonium lactate emulsion with 10% lactic acid emulsion, there were no differences between the treatments; however, consistent with the previous findings, a significant improvement from baseline was observed with both treatments.¹⁵⁷ A new humectant-rich formulation (15% AHA and 15% urea) was also shown to efficiently relieve xerosis and reduce SC thickness of the hyperkeratotic feet.¹⁵⁰ Despite reduction of SC thickness, no weakening of the skin barrier function was observed in the hyperkeratotic skin on the feet, instead the barrier function in the normal forearm skin improved and the skin became more resistant to external insults. Furthermore, no difference in efficacy between once- and twice-daily applications was found.¹⁵⁰

In some studies no superiority was found from treatment with products containing humectants compared to products without humectants.^{155,159} For example, 12% ammonium lactate was equally effective as a liposome-based moisturizing cream in reducing foot xerosis¹⁵⁹ and twice daily application of 12% cream ammonium lactate for four weeks was equally effective as pure lanolin in relieving moderate to severe xerosis.¹⁵⁵ A British standard emulsion (aqueous cream BP, British Pharmacopeia, with conventional emollients and no humectants), was also reported in the early 1970s to be equally effective as a 10% urea cream.¹⁶² However, in a recent study the same aqueous cream showed inferiority to an emulsion with 3% glycerin, 10% urea, and lactic acid using instrumental assessment of degree of hydration of the feet.¹⁵¹

Also, in other dry skin conditions, moisturizers with humectants are effective and superior to those without humectants (Table 19.6).

Moisturizers in Atopic Eczema Therapy

AD is increasingly being considered a primary disorder related to SC barrier failure, where the major predisposing factors for the eczema are mutations in the filaggrin gene.^{170,171} The defect barrier function in AD, measured as elevated TEWL in rough and clinically normal skin,^{90,91} and the enhanced penetration of environmental allergens are suggested to have consequences for the development of eczema and

other conditions such as asthma.¹⁷⁰ Effective strategies for avoiding eczema would therefore be to repair the barrier or to prevent barrier dysfunction.

Conventional therapy for AD is based on anti-inflammatory drugs in the acute phase of the disease, combined with moisturizer treatment.¹⁷² Moisturizer therapy enhances the degree of clearance of the eczema in AD^{173,174} and is expected by health care professionals to prolong the clinical improvement after therapy discontinuation.^{84,175–177}

One moisturizer with 5% urea (Canoderm) has repeatedly been shown to improve skin barrier function to water (i.e., reduce TEWL) and to reduce skin susceptibility to surfactant-induced irritation.^{13,141,178–180} The mechanism for the improvement in skin barrier function is not fully understood. No significant difference in the occlusive effect between the 5% urea-cream and a barrier-deteriorating cream containing lactic-acid and propylene glycol (Locobase) has been detected.²¹ Furthermore, no significant change in SC thickness or changes the projected size of the corneocytes were found in normal skin after treatment with urea.¹⁸¹ However, in a murine model of AD, topically applied urea increased antimicrobial peptide expression and normalized both barrier functions.⁶⁶ The reduced filaggrin expression in a substantial proportion of AD patients has been proposed to be improved by topical applications of urea to the skin of heterozygous null allele carriers.⁶⁶

Delay in Eczema Relapse

Since barrier abnormality is proposed to be the main catalyst of disease activity in atopic eczema, barrier improving therapy should be effective in reducing the risks for eczema.^{5,182} Moisturizers are also shown to offer a steroid-sparing alternative to topical corticosteroids in AD.^{173,183}

The delay in relapse of eczema following treatment with moisturizer in patients with AD has been studied using a non-treated area as control.¹⁸⁴ In the study on atopics, the patients first cleared their eczema with a strong corticosteroid cream before being randomized to either treatment with a 5% urea-containing cream, or no treatment for a maximum period of 26 weeks.¹⁸⁴ The results showed the medium number of eczema-free days to be more than 26 weeks in the cream group and four weeks in the control group. The probability of not having a relapse during the 26-week period was 68% in the moisturizer group and 32% for those not using the moisturizer, which resulted in a 53% relative risk reduction.¹⁸⁴

Furthermore, the relapse of hand eczema has also been delayed by treatment with the 5% urea-moisturizer.¹⁸⁵ The patients with hand eczema were eczema-free during a longer time compared to no-treatment.¹⁸⁵ The median time to relapse showed a tenfold difference between the urea moisturizer and no treatment (20 days vs. 2 days, respectively).

The results from the barrier-strengthening urea-cream study can be compared to results from similar studies focusing on long-term disease control using anti-inflammatory agents. Although these studies have slightly different designs, the results suggest that a barrier-strengthening moisturizer may prevent relapse of eczema to a comparable extent as intermittent treatment with anti-inflammatory medicinals on controlled atopic eczema.^{184,186–190} The close similarity in relapse rate between the 5% urea-cream and the reported anti-inflammatory treatments suggests that the use of barrier-improving treatments is effective in the prevention of eczema. Whether a similar delay in the flare-up of eczema would be observed with a moisturizer without barrier-improving properties has yet to be studied.

Moisturizers in Pediatric Skin Care

In general pediatric skin care guidelines, it is recommended to use emollient/moisturizer treatment to reduce the need for more complicated treatments and associated consultations.^{191–194} AD is among the most frequent chronic conditions in childhood and adolescence, with a cumulative incidence of about 20% in children at five years of age.¹⁹⁵

Not surprisingly, studies show that application of moisturizers to infant skin improves skin condition. For example, bathing of newborns followed by treatment with a cream increases SC hydration and lowers TEWL in certain skin regions compared to bathing only.¹⁹⁶ Bathing without the use of a moisturizer

is suggested to compromise hydration in atopic children.¹⁹⁷ Treatment with lotion will also influence sebum and pH after swimming compared to no treatment.¹⁹⁸ Furthermore, an ointment (Aquaphor) decreased TEWL during the first hours after application and improved skin condition compared to standard skin care.^{199,200} However, no differences between formulations (Aquaphor vs. No Sting) were noted when clinical scoring and TEWL were recorded in premature infants.²⁰¹ The skin bacterial flora and fluid and electrolyte balance have also been studied in neonates after treatment with an ointment (Aquaphor).^{199,200,202} In open studies of a ceramide formulation skin hydration, TEWL and SCORAD improved.²⁰³ SCORAD is a clinical tool to assess the severity of AD; that is, SCORing of Atopic Dermatitis.

However, the use of skin care products have also been questioned due to the risks of inducing eczema and asthma. Regular lotion use was also more common in infants who later develop eczema, but no skin care practice was identified that increased the odds of developing AD in a recent case-control study.²⁰⁴ In another pilot study on neonates, protective effect from emollient therapy was found for the primary prevention of AD, but the conclusion was uncertain as no control group was included in the study.²⁰⁵

The concomitant usage of emollients during anti-inflammatory treatment has been shown to reduce the need for corticosteroid. In one of the first steroid-sparing studies, the effectiveness of hydrocortisone cream plus an emollient (Eucerin), was compared with a regimen of hydrocortisone cream applied twice daily (Table 19.7). After three weeks' treatment, improvements in signs and symptoms of atopic eczema were reported in both groups, with no statistically significant difference between groups, that is, the steroid-sparing effect was confirmed.¹⁸³ In another randomized and controlled study in infants it was found that a lower amount of a high potency topical corticosteroid was used if an emollient (Exomega) was used in conjunction with the steroid.²²² The emollient was applied twice daily to dry, non-inflamed areas of skin over the whole body in the treatment group. However, the emollient did not decrease the consumption of moderate potency topical corticosteroid.²²² The third study compared betamethasone valerate applied twice daily with betamethasone valerate applied in the morning and an emollient applied in the evening. After four weeks no significant differences in SCORAD scores were found, suggesting a steroid-sparing effect from the moisturizer.²²⁶ Also, other trials show steroid-sparing effects^{212,218,220,220} and improvement in clinical signs, such as xerosis and pruritus, with the addition of emollients to the corticosteroid therapy.^{173,175} Treatment with a glycerol-moisturizer (Cetaphil Restoraderm) also increased hydration and promoted decrease in disease severity in mild-to-moderate AD when combined with corticosteroids compared to steroid treatment alone.²¹⁰

Clinical trials have also compared the efficacy of emollient-treatment with treatment with topical corticosteroids. In a randomized study no difference in SCORAD was observed between 5% dexpanthenol ointment²⁰⁷ and hydrocortisone and between licochalcone (also containing 10% glycerol) and hydrocortisone,²¹³ although the effect on edematous scores was superior with the use of hydrocortisone. A moisturizer with sunflower seed oleodistillate was also found equally effective as hydrocortisone using SCORAD and Quality-of-Life as clinical endpoints.²⁰⁸ Furthermore, a medical device foam with ceramides and glycerin was found equally effective as a pimecrolimus cream.²¹¹

In a clinical study addressing the influence of humectants on children suffering from non-bullous ichthyosis it was found that more patients improved in the group treated with 15% glycerol cream compared to the patients treated with its placebo in a randomized, controlled study on 231 children.²⁰⁹ The response to glycerol treatment was related to the scaling score at baseline; the more severe the scaling was, the more responders were obtained; 60% in the glycerol group vs. 14% in the vehicle group when the scaling score was extreme. Reduction in pruritus was also significantly higher with the glycerol cream compared to placebo.²⁰⁹

This 15% glycerol cream also improved patients with ichthyosis vulgaris in a randomized, controlled, bilateral, single-blind study, although the control treatment (10% urea) was superior in reducing degree of scaling, roughness, cracking, and redness.²¹⁵ A lotion with 4% sodium cromoglicate was also found to be superior to its placebo in reducing SCORAD in a randomized study.²²⁵ Furthermore, pale sulfonated shale oil was found superior to its vehicle using clinical scoring of AD.²¹⁶ Neonates treated with lanolin/olive oil ointment also showed statistically less dermatitis than did neonates treated with emollient cream (Bepanthen), and both had a better outcome than those in the control group.²¹⁹

TABLE 19.7

Treatment of Children with Emollients/Moisturizers

Diagnosis/Inclusion/ Design/Duration	No of Children/Age Group	Product	Outcome
Family history of allergic disease, open study, 6 week	10 infants, 0–4 weeks	EpiCeram (contains ceramides, cholesterol, and free fatty acids and petrolatum, low pH)	Support of safety and parental compliance for future prevention of eczema ²⁰⁶
AD, randomized, bilateral, 4 weeks	30 children, mean age 7.2 years	5% dexpantenol ointment vs. hydrocortisone	No difference in SCORAD, but faster resolution of edematous scores with hydrocortisone ²⁰⁷
AD, open randomized, 3 weeks	40 children, 3 months–4 years	2% sunflower seed oleodistillate cream vs. hydrocortisone	Equally effective using SCORAD and Quality-of-Life ²⁰⁸
Prospective, randomized, placebo-controlled, non-bullous ichthyosis, 4 weeks + follow up after 8 more weeks	Under 18 years	Dexeryl (15% glycerol and 10% white-soft and liquid paraffin) vs. placebo	More patients improved in the glycerol group and less pruritus was noted ²⁰⁹
Randomized, bilateral, evaluator-blinded, Short and 3 weeks	Children and adults	Cetaphil Restoraderm™	Single application increased hydration compared to control, more rapid restoration after SLS, decrease of itching/stinging compared to baseline, a more rapid decrease of disease severity in combination with topical steroid ²¹⁰
Wide age group		Medical device foam Hylatopic vs. Pimecrolimus	Both effective, 82% almost clear with foam and 71% with pim cream ²¹¹
AD, Prospective observational study	33 children, 5–18 years	Pseudoceramide-containing cream (Curel)	Improved hydration, fewer used topical corticosteroids, no deterioration in TEWL, severity, QoL by the cream ²¹²
Childhood	Mean age 5.8 years	Licochalcone/vitamin B12 moisturizer vs. HC lotion Glycerol 10%	No difference in reduction of SCORAD score, but more rapid resolution of edema and erythema in HC ²¹³
AD patients, randomized, controlled, 21 days	39 children, 2–17 years	Atopiclair (glycyrrhetic acid), EpiCeram (ceramide-dominant), Aquaphor Healing ointment (petroleum based)	No significant differences in efficiency ²¹⁴
Ichthyosis vulgaris, randomized, controlled, single-blind, bilateral, 4 weeks	30 patients (8–65 years)	Urea (10%) vs. 15% glycerol /paraffin (Dexeryl)	Both treatments improved skin, urea was superior (scaling, roughness, cracking, redness) ²¹⁵
Randomized	44 infants, 3–6 months	Baby lotion or no lotion after swimming 4 times	Sebum and pH stable and higher in lotion group compared to no lotion ¹⁹⁸

(Continued)

TABLE 19.7 (Continued)

Treatment of Children with Emollients/Moisturizers

Diagnosis/Inclusion/ Design/Duration	No of Children/Age Group	Product	Outcome
99 children with AD, randomized, vehicle-controlled, 4 weeks		Pale sulfonated shale oil 4% cream vs. vehicle	Active significantly superior to vehicle, clinical scoring ²¹⁶
Randomized/2 weeks	69/ < 33 weeks	No-Sting vs. Aquaphor	Neonatal Skin Condition Score and TEWL equal in both groups ²⁰¹
High risk AD, AD, pilot study	22 neonates, 547 days	Barrier protection	Barrier measurements within normal range, possible protection against AD outbreak ²⁰⁵
Neonates, 8 weeks treatment	64 neonates, <48 h	Bathing with and without wash gels and a cream	Wash gel + cream lowered TEWL, increased hydration in certain skin regions ¹⁹⁶
AD, 4 weeks, open	30, 5–19 years	Ceramide-fatty acids-cholest emollient	Decreased SCORAD, improved skin symptoms, increased hydration, no effect on TEWL ²¹⁷
Infants and babies with AD, initial evaluation		2% sunflower oleodistillate	Steroid-sparing effect, positive QoL ²¹⁸
AD, cross-over	5 AD + 5 healthy, pediatric	Combination bathing with emollient	Bathing without moisturizer may compromise hydration, and bathing followed by moisturizer provides modest benefit ¹⁹⁷
AD, randomized, open, 2 + 4 week	52 children 2–12 year	Corticosteroid with and without emollient 2 weeks and then 4 weeks without corticosteroid	Both groups improved. Superior with emollient and improvement was maintained during the 4 weeks of follow up ¹⁷⁵
Neonatal, prospective. Randomized preterm/4 weeks	173 infants/between 25 and 36 weeks	Bepanthen/olive oil cream (70% lanolin, 30% olive oil)/control group	Less dermatitis in olive oil group compared to emollient cream and control group in weeks 2–4 ²¹⁹
86 patients with AD	4–48 months	Once or twice daily hydrocortisone equally vs. hydrocortisone every other day combined with natural cream	Steroid-sparing effect when combined with natural cream ²²⁰
76 children, AD, randomized, parallel groups	6 months–12 years	Twice daily moisturizer milk (Exomega) for 2 months vs. no treatment (cleansing bar and corticosteroids were allowed in both groups)	No significant decrease in SCORAD, but improvement in xerosis and pruritus ¹⁷³
Observational, non-controlled, prospective cohort, 6 weeks	2456 patients, 2–70 years	Lamellar matrix containing N-palmitoyl-ethanolamine (Physiogel)	Related effectiveness (decline of pruritus and loss of sleep) indicated a gain in quality of life, reduced use of topical corticosteroids ²²¹
AD, randomized controlled. 6 weeks	173 infants <12 months	Corticosteroids with and without emollient (Exomega)	Emollient steroid-sparing ²²²
AD	37 atopic infants + 186 normal infants	Pure petrolatum, oil-in-water cream with humectant	Increased capacitance in both groups ²²³

(Continued)

TABLE 19.7 (Continued)

Treatment of Children with Emollients/Moisturizers

Diagnosis/Inclusion/ Design/Duration	No of Children/Age Group	Product	Outcome
Neonates	18 neonates ≤27 weeks on cream and 36 controls	Aquaphor	Treatment beneficial for fluid and electrolyte balance in extreme preterm infants ²⁰²
Eczema and suspected food allergy	123 children, <2 years	Skin care	Skin care effective ²²⁴
AD, randomized, placebo controlled	48 + 56 children aged 2–12 years	Lotion 4% sodium cromoglicate (Altoderm) vs. base	Both effective using SCORAD and active more effective ²²⁵
Childhood AD, 20–21 weeks	24 children	Ceramide-repair emollient vs. no control	Improvement in SCORAD, decreased TEWL, improved hydration ²⁰³
Open, bilateral, 4 weeks	50 children, mean age 3.5 years	Topical corticosteroids alone versus corticosteroid plus emollient	SCORAD showed improvement from both treatments and no significant difference, i.e., steroid-sparing effect. ²²⁶
Randomized, 2 weeks	60/< 33 weeks	Preservative-free ointment (Aquaphor) vs. no treatment or as-needed with a water-in-oil emollient (Eucerin)	Decreased TEWL during the first 6 hrs after application. Superior skin condition, less skin bacterial colonization, etc. ¹⁹⁹
2 weeks	19/26–30 weeks	Aquaphor ointment twice daily or standard skin care	Improved skin scores, no other differences ²⁰⁰
AD, 3 weeks	Children 3–15 years	Once-daily hydrocortisone + water-in-oil (Eucerin) vs. twice daily hydrocortisone	No difference in improvement (size of lesions and rate) i.e., water-in-oil steroid sparing ¹⁸³
Premature neonates, 16 days	29–36 weeks	Water-in-oil (Eucerin Crème) emollient vs. controls	Less dermatitis in hands, feet, abdomen from cream, no difference in microflora ²²⁷

Notes: The studies are in publication order with the most recent ones on top of the table; TEWL, Transepidermal water loss; SCORAD, SCORing of Atopic Dermatitis.

Concluding Remarks

The composition, formation, and function of the SC have been the subject of intense research over the last decades. Topically applied moisturizers contain ingredients which penetrate into the skin and affect the SC architecture and barrier homeostasis. The types of problems covered by the term dry skin may not always be diminished by an increase in skin hydration. It therefore seems essential to identify the underlying pathogenesis and to detect agents that assist the cellular differentiation process or act as precursors to vital SC components.

A number of different mechanisms behind the barrier improving effects from moisturizers have been suggested. It is obvious that an immediate reduction in TEWL may be due to a simple deposition of fatty material to the surface, and not to any deeper effects in the skin. Another explanation is increased skin hydration, which increase SC elasticity and decrease the risks of cracks and fissures. Interference with the lipid layer around the corneocytes may also help to retain the moisture content in the corneocytes and prevent cracking of the SC. Moreover, it is possible that the applied moisturizer decreases the proliferative activity of the epidermis, which increases the size of the corneocytes. With a larger corneocyte area, the tortuous lipid pathway gives a longer distance for penetration, which reduces the permeability. Furthermore, changes of the diffusional resistance through different skin structures may be crucial for the permeability.

In conclusion, increased understanding of the interactions between topically applied substances and the epidermal biochemistry will enhance the possibilities to tailor moisturizing creams for various types of SC. Furthermore, the non-invasive bioengineering techniques should be able to diagnose specific skin defects and allow us to monitor and compare treatment effects more closely.

REFERENCES

1. Leveque JL, Grove GL, de Rigal J et al. Biophysical characterization of dry facial skin. *J Soc Cosmet Chem* 1987;82:171–7.
2. de Rigal J, Losch MJ, Bazin R et al. Near-infrared spectroscopy: A new approach to the characterization of dry skin. *J Soc Cosmet Chem* 1993;44:197–209.
3. Linde YW. “Dry” skin in atopic dermatitis. A clinical study. *Acta Derm Venereol (Stockh)* 1989;69:311–4.
4. Jemec GBE, Serup J. Scaling, dry skin and gender. *Acta Derm Venereol* 1992;177(Suppl):26–8.
5. Elias PM, Wood LC, Feingold KR. Epidermal pathogenesis of inflammatory dermatoses. *Am J Contact Dermat* 1999;10(3):119–26.
6. Wellner K, Wohlrab W. Quantitative evaluation of urea in stratum corneum of human skin. *Arch Dermatol Res* 1993;285:239–40.
7. Imokawa G, Abe A, Jin K et al. Decreased level of ceramides in stratum corneum of atopic dermatitis: An etiologic factor in atopic dry skin? *J Invest Dermatol* 1991;96(4):523–6.
8. Melnik B, Hollmann J, Hofmann U et al. Lipid composition of outer stratum corneum and nails in atopic and control subjects. *Arch Dermatol Res* 1990;282:549–51.
9. Jacobson TM, Yukse IU, Greensin JC et al. Effects of aging and xerosis on the amino acid composition of human skin. *J Invest Dermatol* 1990;95:296–300.
10. Horii I, Nakayama Y, Obata M et al. Stratum corneum hydration and amino acid content in xerotic skin. *Br J Dermatol* 1989;121:587–92.
11. Sörensen A, Landvall P, Lodén M. Moisturizers as cosmetics, medicines, or medical device? The regulatory demands in the European Union. In: Lodén M, Maibach HI, eds. *Treatment of Dry Skin Syndrome. The Art and Science of Moisturizers*. Berlin, Heidelberg: Springer; 2012, pp.3–16.
12. Korting HC, Schollmann C. Medical devices in dermatology: Topical semi-solid formulations for the treatment of skin diseases. *J Dtsch Dermatol Ges* 2011;10:103–9.
13. Buraczewska I, Berne B, Lindberg M et al. Changes in skin barrier function following long-term treatment with moisturizers, a randomized controlled trial. *Br J Dermatol* 2007;156(3):492–8.
14. Held E, Sveinsdottir S, Agner T. Effect of long-term use of moisturizers on skin hydration, barrier function and susceptibility to irritants. *Acta Derm Venereol (Stockh)* 1999;79:49–51.
15. Zachariae C, Held E, Johansen JD et al. Effect of a moisturizer on skin susceptibility to NiCl₂. *Acta Derm Venereol* 2003;83(2):93–7.

16. Rhodes LE. *Essential Fatty Acids. Dry Skin and Moisturizers: Chemistry and Function*. Boca Raton, FL: CRC Press; 2000, pp. 311–25.
17. Kibbe AW. *Handbook of Pharmaceutical Excipients*, 3rd edn. Washington, DC: American Pharmaceutical Association, Pharmaceutical Press; 2000.
18. Rawlings AV, Lombard KJ. A review on the extensive skin benefits of mineral oil. *Int J Cosmet Sci* 2012;34(6):511–8.
19. Lodén M, Lindberg M. The influence of a single application of different moisturizers on the skin capacitance. *Acta Derm Venereol* 1991;71(1):79–82.
20. Lodén M. The increase in skin hydration after application of emollients with different amounts of lipids. *Acta Derm Venereol* 1992;72(5):327–30.
21. Buraczewska I, Brostrom U, Loden M. Artificial reduction in transepidermal water loss improves skin barrier function. *Br J Dermatol* 2007;157(1):82–6.
22. Caussin J, Groenink HW, de Graaff AM et al. Lipophilic and hydrophilic moisturizers show different actions on human skin as revealed by cryo scanning electron microscopy. *Exp Dermatol* 2007;16(11):891–8.
23. Imokawa G, Akasaki S, Hattori M et al. Selective recovery of deranged water-holding properties by stratum corneum lipids. *J Invest Dermatol* 1986;87(6):758–61.
24. Man MQ, Feingold KR, Elias PM. Exogenous lipids influence permeability barrier recovery in acetone-treated murine skin. *Arch Dermatol* 1993;129(6):728–38.
25. Wertz PW, Downing DT. Metabolism of topically applied fatty acid methyl esters in BALB/C mouse epidermis. *J Derm Sci* 1990;1:33–8.
26. Moloney SJ. The *in vitro* percutaneous absorption of glycerol trioleate through hairless mouse skin. *J Pharm Pharmacol* 1988;40:819–21.
27. Rawlings AV, Scott IR, Harding CR et al. Stratum corneum moisturization at the molecular level. *J Invest Dermatol* 1995;103:731–40.
28. Escobar SO, Achenbach R, Innantuono R et al. Topical fish oil in psoriasis—A controlled and blind study. *Clin Exp Dermatol* 1992;17:159–62.
29. Tollesson A, Frithz A. Borage oil, an effective new treatment for infantile seborrhoeic dermatitis. *Br J Dermatol* 1993;129(1):95.
30. Feingold KR, Brown BE, Lear SR et al. Effect of essential fatty acid deficiency on cutaneous sterol synthesis. *J Invest Dermatol* 1986;87(5):588–91.
31. Danby SG, AlEnezi T, Sultan A et al. Effect of olive and sunflower seed oil on the adult skin barrier: Implications for neonatal skin care. *Pediatr Dermatol* 2013;30(1):42–50.
32. Miller CC, Tang W, Ziboh VA et al. Dietary supplementation with ethyl ester concentrates of fish oil (n-3) and borage oil (n-6) polyunsaturated fatty acids induces epidermal generation of local putative anti-inflammatory metabolites. *J Invest Dermatol* 1991;96:98–103.
33. Schurer NY. Implementation of fatty acid carriers to skin irritation and the epidermal barrier. *Contact Dermatitis* 2002;47(4):199–205.
34. Sheu MY, Fowler AJ, Kao J et al. Topical peroxisome proliferator activated receptor-alpha activators reduce inflammation in irritant and allergic contact dermatitis models. *J Invest Dermatol* 2002;118(1):94–101.
35. Fowler AJ, Sheu MY, Schmutz M et al. Liver X receptor activators display anti-inflammatory activity in irritant and allergic contact dermatitis models: Liver-X-receptor-specific inhibition of inflammation and primary cytokine production. *J Invest Dermatol* 2003;120(2):246–55.
36. Komuves LG, Hanley K, Jiang Y et al. Ligands and activators of nuclear hormone receptors regulate epidermal differentiation during fetal rat skin development. *J Invest Dermatol* 1998;111(3):429–33.
37. Dewsbury CE, Graham P, Darley CR. Topical eicosapentaenoic acid (EPA) in the treatment of psoriasis. *Br J Dermatol* 1989;120:581.
38. Gupta AK, Ellis CN, Goldfarb MT et al. The role of fish oil in psoriasis. A randomized, double blind, placebo-controlled study to evaluate the effect of fish oil and topical corticosteroid therapy in psoriasis. *Int J Derm* 1990;29:591–95.
39. Zepelin HHH-V, Mrowietz U, Färber L et al. Highly purified omega-3-polyunsaturated fatty acids for topical treatment of psoriasis. Results of a double-blind, placebo-controlled multicentre study. *Br J Dermatol* 1993;129:713–7.
40. Hartop PJ, Allenby CF, Prottey C. Comparison of barrier function and lipids in psoriasis and essential fatty acid-deficient rats. *Clin Exp Dermatol* 1978;3:259–67.

41. Wright S, Burton JL. Oral evening-primrose-seed oil improves atopic eczema. *Lancet* 1982;2:1120–2.
42. Hederos CA, Berg A. Epogam evening primrose oil treatment in atopic dermatitis and asthma. *Arch Dis Child* 1996;75:494–7.
43. Bamford JTM, Gibson RW, Renier CM. Atopic eczema unresponsive to evening primrose oil (linoleic and γ -linolenic acids). *J Am Acad Dermatol* 1985;13:959–65.
44. Henz BM, Jablonska S, van de Kerkhof PCM et al. Double-blind, multicentre analysis of the efficacy of borage oil in patients with atopic dermatitis. *Br J Dermatol* 1999;140:685–8.
45. Laden K, Spitzer R. Identification of a natural moisturizing agent in skin. *J Soc Cosmet Chem* 1967;18:351–60.
46. Huttinger R. Restoring hydrophilic properties to the stratum corneum—A new humectant. *Cosmet Toilet* 1978;93:61–2.
47. Rosten M. The treatment of ichthyosis and hyperkeratotic conditions with urea. *Aust J Derm* 1970;11:142–4.
48. Laden K. Natural moisturization factors in skin. *Am Perfum Cosmet* 1967;82:77–9.
49. Budavari S. *The Merck Index*. Rahway: Merck & Co; 1989.
50. Norlén L, Emilson A, Forslind B. Stratum corneum swelling. Biophysical and computer assisted quantitative assessments. *Arch Dermatol Res* 1997;289:506–13.
51. Van Hal DA, Jeremiase E, Junginger HE et al. Structure of fully hydrated human stratum corneum: A freeze-fracture electron microscopy study. *J Invest Dermatol* 1996;106(1):89–95.
52. Batt MD, Davis WB, Fairhurst E et al. Changes in the physical properties of the stratum corneum following treatment with glycerol. *J Soc Cosmet Chem* 1988;39:367–81.
53. Swanbeck G. A new treatment of ichthyosis and other hyperkeratotic conditions. *Acta Derm-Venereol (Stockh)* 1968;48:123–7.
54. Grice K, Sattar H, Baker H. Urea and retinoic acid in ichthyosis and their effect on transepidermal water loss and water holding capacity of stratum corneum. *Acta Derm Venereol (Stockh)* 1973;54:114–8.
55. Tagami H. Electrical measurement of the water content of the skin surface. Functional analysis of the hygroscopic property and water-holding capacity of the stratum corneum *in vivo* and technique for assessing moisturizing efficacy. *Cosmet Toilet* 1982;97:39–47.
56. Middleton J. Development of a skin cream designed to reduce dry and flaky skin. *J Soc Cosmet Chem* 1974;25:519–34.
57. Alderson SG, Barratt MG, Black JG. Effect of 2-hydroxyacids on guinea-pig footpad stratum corneum: Mechanical properties and binding studies. *Int J Cosmet Sci* 1984;6:91.
58. Takahashi M, Machida Y, Tsuda Y. The influence of hydroxy acids on the rheological properties of stratum corneum. *J Soc Cosmet Chem* 1985;36:177–87.
59. Hall KJ, Hill JC. The skin plasticisation effect of 2-hydroxyoctanoic acid. 1: The use of potentiators. *J Soc Cosmet Chem* 1986;37:397–407.
60. Jokura Y, Ishikawa S, Tokuda H et al. Molecular analysis of elastic properties of the stratum corneum by solid-state ^{13}C -nuclear magnetic resonance spectroscopy. *J Invest Dermatol* 1995;104(5):806–12.
61. Mattai J, Froebe CL, Rhein LD et al. Prevention of model stratum corneum lipid phase transitions *in vitro* by cosmetic additives—Differential scanning calorimetry, optical microscopy, and water evaporation studies. *J Soc Cosmet Chem* 1993;44:89–100.
62. Froebe CL, Simion FA, Ohlmeyer H et al. Prevention of stratum corneum lipid phase transitions *in vitro* by glycerol—An alternative mechanism for skin moisturization. *J Soc Cosmet Chem* 1990;41:51–65.
63. Rawlings AV, Harding C, Watkinson A et al. The effect of glycerol and humidity on desmosome degradation in stratum corneum. *Arch Dermatol Res* 1995;287:457–64.
64. Summers RS, Summers B, Chandar P et al. The effect of lipids, with and without humectant, on skin xerosis. *J Soc Cosmet Chem* 1996;47:27–39.
65. Costa-Balogh FO, Wennerstrom H, Wadso L et al. How small polar molecules protect membrane systems against osmotic stress: The urea-water-phospholipid system. *J Phys Chem B* 2006;110(47):23845–52.
66. Grether-Beck S, Felsner I, Brenden H et al. Urea uptake enhances barrier function and antimicrobial defense in humans by regulating epidermal gene expression. *J Invest Dermatol* 2012;132(6):1561–72.
67. Horii Y, Tanida M, Shen J et al. Skin application of urea-containing cream affected cutaneous arterial sympathetic nerve activity, blood flow, and water evaporation. *Skin Res Technol* 2011;17(1):75–81.
68. Balazs EA, Band P. Hyaluronic acid: Its structure and use. *Cosmet Toilet* 1984;99:65–72.

69. Lundov MD, Johansen JD, Zachariae C et al. Creams used by hand eczema patients are often contaminated with *Staphylococcus aureus*. *Acta Derm Venereol* 2012;92(4):441–2.
70. Brockow K, Grabenhorst P, Abeck D et al. Effect of gentian violet, corticosteroid and tar preparations in *Staphylococcus aureus*-colonized atopic eczema. *Dermatology* 1999;199(3):231–6.
71. Gallo RL, Nizet V. Endogenous production of antimicrobial peptides in innate immunity and human disease. *Curr Allergy Asthma Rep* 2003;3(5):402–9.
72. Lundstrom A, Egelrud T. Cell shedding from human plantar skin *in vitro*: Evidence of its dependence on endogenous proteolysis. *J Invest Dermatol* 1988;91(4):340–3.
73. Nicholls S, King CS, Marks R. Short term effects of emollients and a bath oil on the stratum corneum. *J Soc Cosmet Chem* 1978;29:617–24.
74. Garber CA, Nightingale CT. Characterizing cosmetic effects and skin morphology by scanning electron microscopy. *J Soc Cosmet Chem* 1976;27:509–31.
75. Lodén M, Olsson H, Skare L et al. Instrumental and sensory evaluation of the frictional response of the skin following a single application of five moisturizing creams. *J Soc Cosmet Chem* 1992;43:13–20.
76. Batt MD, Fairhurst E. Hydration of the stratum corneum. *Int J Cosmet Sci* 1986;8:253–64.
77. Murahata RI, Crowe DM, Roheim JR. Evaluation of hydration state and surface defects in the stratum corneum: Comparison of computer analysis and visual appraisal of positive replicas of human skin. *J Soc Cosmet Chem* 1984;35:327–38.
78. Mignot J, Zahouani H, Rondot D et al. Morphological study of human skin relief. *Bioeng Skin* 1987;3:177–96.
79. Cook TH, Craft TJ. Topographics of dry skin, non-dry skin, and cosmetically treated dry skin as quantified by skin profilometry. *J Soc Cosmet Chem* 1985;36:143–52.
80. Rhodes LE, Diffey BL. Fluorescence spectroscopy: A rapid, noninvasive method for measurement of skin surface thickness of topical agents. *Br J Dermatol* 1997;136(1):12–7.
81. Johnson R, Nusbaum BP, Horwitz SN et al. Transfer of topically applied tetracycline in various vehicles. *Arch Dermatol* 1983;119(8):660–3.
82. Ivens UI, Steinkjer B, Serup J et al. Ointment is evenly spread on the skin, in contrast to creams and solutions. *Br J Dermatol* 2001;145:264–7.
83. Loden M, Buraczewska I, Halvarsson K. Facial anti-wrinkle cream: Influence of product presentation on effectiveness: A randomized and controlled study. *Skin Res Technol* 2007;13(2):189–94.
84. Holden C, English J, Hoare C et al. Advised best practice for the use of emollients in eczema and other dry skin conditions. *J Dermatolog Treat* 2002;13(3):103–6.
85. Schlagel CA, Sanborn EC. The weights of topical preparations required for total and partial body inunction. *J Invest Dermatol* 1964;42:253–6.
86. Lynfield YL, Schechter BA. Choosing and using a vehicle. *J Am Acad Dermatol* 1984;10:56–9.
87. Kolbe L. Non-invasive methods for testing of the stratum corneum barrier function. In: Lodén M, Maibach HI, eds. *Dry Skin and Moisturizers: Chemistry and Function*. Boca Raton, FL: CRC Press; 2000, pp. 393–401.
88. Denda M, Koyama J, Namba R et al. Stratum corneum lipid morphology and transepidermal water loss in normal skin and surfactant-induced scaly skin. *Arch Dermatol Res* 1994;286(1):41–6.
89. Thune P. Evaluation of the hydration and the water-holding capacity in atopic skin and so-called dry skin. *Acta Derm Venereol (Suppl)*; 1989;144:133–5.
90. Lodén M, Olsson H, Axell T et al. Friction, capacitance and transepidermal water loss (TEWL) in dry atopic and normal skin. *Br J Dermatol* 1992;126(2):137–41.
91. Werner Y, Lindberg M. Transepidermal water loss in dry and clinically normal skin in patients with atopic dermatitis. *Acta Derm Venereol* 1985;65(2):102–5.
92. Serup J, Blichmann CW. Epidermal hydration of psoriasis plaques and the relation to scaling. Measurement of electrical conductance and transepidermal water loss. *Acta Derm Venereol (Stockh)* 1987;67:357–9.
93. Motta S, Monti M, Sesana S et al. Abnormality of water barrier function in psoriasis. *Arch Dermatol* 1994;130:452–6.
94. Ghadially R, Reed JT, Elias PM. Stratum corneum structure and function correlates with phenotype in psoriasis. *J Invest Dermatol* 1996;107(4):558–64.
95. Blank IH. Factors which influence the water content of the stratum corneum. *J Invest Dermatol* 1952;18:433–40.

96. Blank IH. Further observations on factors which influence the water content of the stratum corneum. *J Invest Dermatol* 1953;21:259–71.
97. Potts RO, Francoeur ML. The influence of stratum corneum morphology on water permeability. *J Invest Dermatol* 1991;96:495–9.
98. Rougier A, Lotte C, Corcuff P et al. Relationship between skin permeability and corneocyte size according to anatomic site, age, and sex in man. *J Soc Cosmet Chem* 1988;39:15–26.
99. Grove GL, Kligman AM. Corneocytes size as an indirect measure of epidermal proliferative activity. In: Marks R, Plewig G, eds. *Stratum Corneum*. New York: Springer; 1983, pp.191–4.
100. Imokawa G, Akasaki S, Minematsu Y et al. Importance of intercellular lipids in water-retention properties of the stratum corneum: Induction and recovery study of surfactant dry skin. *Arch Dermatol Res* 1989;281(1):45–51.
101. Elias PM. Lipids and the epidermal permeability barrier. *Arch Dermatol Res* 1981;270(1):95–117.
102. Downing DT. Lipid and protein structures in the permeability barrier. In: Lodén M, Maibach HI, eds. *Dry Skin and Moisturizers; Chemistry and Function*. Boca Raton, FL: CRC Press; 2000, pp.59–70.
103. Elias PM, Cooper ER, Korc A et al. Percutaneous transport in relation to stratum corneum structure and lipid composition. *J Invest Dermatol* 1981;76(4):297–301.
104. Elias PM, Menon GK. Structural and lipid biochemical correlates of the epidermal permeability barrier. *Adv Lipid Res* 1991;24:1–26.
105. White SH, Mirejovsky D, King GI. Structure of lamellar lipid domains and corneocyte envelopes of murine stratum corneum. An X-ray diffraction study. *Biochemistry* 1988;27:3725–32.
106. Knutson K, Krill SL, Lambert WJ et al. Physicochemical aspects of transdermal permeation. *J Control Rel* 1987;6:59–74.
107. Forslind B. A domain mosaic model of the skin barrier. *Acta Derm Venereol (Stockh)* 1994;74:1–6.
108. Lampe MA, Burlingame AL, Whitney J et al. Human stratum corneum lipids: Characterization and regional variations. *J Lipid Res* 1983;24(2):120–30.
109. Denda M, Koyama J, Hori J et al. Age- and sex-dependent change in stratum corneum sphingolipids. *Arch Dermatol Res* 1993;285(7):415–7.
110. Rawlings AV, Conti A, Rogers J et al. Seasonal influences on stratum corneum ceramide 1 linoleate content and the influence of topical essential fatty acids. Paper presented at 18th Int IFSCC Congr, October 3–6, 1994; Venice, Italy.
111. Fulmer AW, Kramer GJ. Stratum corneum lipid abnormalities in surfactant-induced dry scaly skin. *J Invest Dermatol* 1986;86(5):598–602.
112. Imokawa G, Hattori M. A possible function of structural lipids in the water-holding properties of the stratum corneum. *J Invest Dermatol* 1985;84(4):282–4.
113. Feingold KR, Man MQ, Menon GK et al. Cholesterol synthesis is required for cutaneous barrier function in mice. *J Clin Invest* 1990;86(5):1738–45.
114. Denda M, Hori J, Koyama J et al. Stratum corneum sphingolipids and free amino acids in experimentally-induced scaly skin. *Arch Dermatol Res* 1992;284(6):363–7.
115. Yamamoto A, Serizawa S, Ito M et al. Stratum corneum lipid abnormalities in atopic dermatitis. *Arch Dermatol Res* 1991;283:219–23.
116. Motta S, Sesana S, Ghidoni R et al. Content of the different lipid classes in psoriatic scale. *Arch Dermatol Res* 1995;287:691–4.
117. Paige DG, Morse-Fisher N, Harper JJ. Quantification of stratum corneum ceramides and lipid envelope ceramides in the hereditary ichthyosis. *Br J Dermatol* 1994;131:23–7.
118. Held E, Lund H, Agner T. Effect of different moisturizers on SLS-irritated human skin. *Contact Dermatitis* 2001;44:229–34.
119. Lodén M. Urea-containing moisturizers influence barrier properties of normal skin. *Arch Dermatol Res* 1996;288(2):103–7.
120. Kolbe L, Kligman AM, Stoudemayer T. Objective bioengineering methods to assess the effects of moisturizers on xerotic leg of elderly people. *J Dermatol Treat* 2000;11:241–5.
121. Gånemo A, Virtanen M, Vahlquist A. Improved topical treatment of lamellar ichthyosis: A double blind study of four different cream formulations. *Br J Dermatol* 1999;141:1027–32.
122. Halkier-Sorensen L, Thestrup-Pedersen K. The efficacy of a moisturizer (Locobase) among cleaners and kitchen assistants during everyday exposure to water and detergents. *Contact Dermatitis* 1993;29(5):266–71.

123. Hachem JP, De Paepe K, Vanpée E et al. The effect of two moisturisers on skin barrier damage in allergic contact dermatitis. *Eur J Dermatol* 2002;12:136–8.
124. Duval D, Lindberg M, Boman A et al. Differences among moisturizers in affecting skin susceptibility to hexyl nicotinate, measured as time to increase skin blood flow. *Skin Res Technol* 2002;8:1–5.
125. Tsang M, Guy RH. Effect of aqueous cream BP on human stratum corneum *in vivo*. *Br J Dermatol* 2010;163:954–8.
126. Lodén M. Barrier recovery and influence of irritant stimuli in skin treated with a moisturizing cream. *Contact Dermatitis* 1997;36(5):256–60.
127. Serup J. A double-blind comparison of two creams containing urea as the active ingredient. Assessment of efficacy and side-effects by non-invasive techniques and a clinical scoring scheme. *Acta Derm Venereol, Suppl* 1992;177:34–43.
128. Tanno O, Ota Y, Kitamura N et al. Nicotinamide increases biosynthesis of ceramides as well as other stratum corneum lipids to improve the epidermal permeability barrier. *Br J Dermatol* 2000;143(3):524–31.
129. Fluhr JW, Gloor M, Lehmann L et al. Glycerol accelerates recovery of barrier function *in vivo*. *Acta Derm Venereol* 1999;79(6):418–21.
130. Kucharekova M, Schalkwijk J, Van de Kerkhof PCM et al. Effect of a lipid-rich emollient containing ceramide 3 in experimentally induced skin barrier dysfunction. *Contact Dermatitis* 2002;46:331–8.
131. Ghadially R, Halkier_Sorensen L, Elias PM. Effects of petrolatum on stratum corneum structure and function. *J Am Acad Dermatol* 1992;26(3 Pt 2):387–96.
132. Thornfeldt C. Critical and optimal molar ratios of key lipids. In: Lodén M, Maibach HI, eds. *Dry Skin and Moisturizers: Chemistry and Function*. Boca Raton, FL: CRC Press; 2000, pp.337–47.
133. De Paepe K, Derde M-P, Reseeuw D et al. Incorporation of ceramide 3B in dermatocosmetic emulsions: Effect of the transepidermal water loss of sodium lauryl sulphate-damaged skin. *JAEDV* 2000;14:272–9.
134. Lodén M, Barany E. Skin-identical lipids versus petrolatum in the treatment of tape-stripped and detergent-perturbed human skin. *Acta Derm Venereol* 2000;80(6):412–5.
135. Zettersten EM, Ghadially R, Feingold KR et al. Optimal ratios of topical stratum corneum lipids improve barrier recovery in chronologically aged skin. *J Am Acad Dermatol* 1997;37:403–8.
136. Kucharekova M, Van De Kerkhof PC, Van Der Valk PG. A randomized comparison of an emollient containing skin-related lipids with a petrolatum-based emollient as adjunct in the treatment of chronic hand dermatitis. *Contact Dermatitis* 2003;48(6):293–9.
137. Mortz CG, Andersen KE, Halkier-Sørensen L. The efficacy of different moisturizers on barrier recovery in hairless mice evaluated by non-invasive bioengineering methods. A model to select the potentially most effective product. *Contact Dermatitis* 1997;36:297–310.
138. Barany E, Lindberg M, Lodén M. Unexpected skin barrier influence from nonionic emulsifiers. *Int J Pharm* 2000;195(1–2):189–95.
139. Proksch E, Nissen HP. Dexpanthenol enhances skin barrier repair and reduces inflammation after sodium lauryl sulphate-induced irritation. *J Dermatol Treat* 2002;13:173–8.
140. Vilaplana J, Coll J, Trullás C et al. Clinical and non-invasive evaluation of 12% ammonium lactate emulsion for the treatment of dry skin in atopic and non-atopic subjects. *Acta Derm Venereol (Stockh)* 1992;72:28–33.
141. Andersson A-C, Lindberg M, Lodén M. The effect of two urea-containing creams on dry, eczematous skin in atopic patients. I. Expert, patient and instrumental evaluation. *J Dermatol Treat* 1999;10:165–9.
142. Van Scott EJ, Yu RJ. Control of keratinization with alpha-hydroxy acids and related compounds. I. Topical treatment of ichthyotic disorders. *Arch Dermatol* 1974;110:586–90.
143. Blair C. The action of a urea-lactic acid ointment in ichthyosis. With particular reference to the thickness of the horny layer. *Br J Dermatol* 1976;94:145–53.
144. Van Scott EJ, Yu RJ. Hyperkeratinization, corneocyte cohesion, and alpha hydroxy acids. *J Am Acad Dermatol* 1984;11:867–79.
145. Yu RJ, Van Scott EJ. Alpha-hydroxy acids: Science and therapeutic use. *Cos Derm* 1994(Suppl):1–6.
146. Zettersten E, Man MQ, Sato J et al. Recessive x-linked ichthyosis: Role of cholesterol-sulfate accumulation in the barrier abnormality. *J Invest Dermatol* 1998;111(5):784–90.
147. Lykkesfeldt G, Hoyer H. Topical cholesterol treatment of recessive X-linked ichthyosis. *Lancet* 1983;2(8363):1337–8.
148. Kuster W, Bohnsack K, Rippke F et al. Efficacy of urea therapy in children with ichthyosis. A multicenter randomized, placebo-controlled, double-blind, semilateral study. *Dermatology* 1998;196:217–22.

149. Redondo P, Bauza A. Topical N-acetylcysteine for lamellar ichthyosis. *Lancet* 1999;354:1880.
150. Loden M, von Scheele J, Michelson S. The influence of a humectant-rich mixture on normal skin barrier function and on once- and twice-daily treatment of foot xerosis. A prospective, randomized, evaluator-blind, bilateral and untreated-control study. *Skin Res Technol* 2013.
151. Baalham P, Birch I, Young M et al. Xerosis of the feet: A comparative study on the effectiveness of two moisturizers. *Br J Community Nurs* 2011;16(12):591–2, 594–7.
152. Borelli C, Bielfeldt S, Borelli S et al. Cream or foam in pedal skin care: Towards the ideal vehicle for urea used against dry skin. *Int J Cosmet Sci* 2011;33(1):37–43.
153. Garrigue E, Martini J, Cousty-Pech F et al. Evaluation of the moisturizer Pedimed® in the foot care of diabetic patients. *Diabetes Metab* 2011;37(4):330–5.
154. Grossman AB. Clinical evaluation of 35% urea in a water-lipid-based foam containing lactic acid for treatment of mild-to-moderate xerosis of the foot. *J Am Podiatr Med Assoc* 2011;101(2):153–8.
155. Jennings MB, Alfieri DM, Parker ER et al. A double-blind clinical trial comparing the efficacy and safety of pure lanolin versus ammonium lactate 12% cream for the treatment of moderate to severe foot xerosis. *Cutis* 2003;71(1):78–82.
156. Pham HT, Exelbert L, Segal-Owens AC et al. A prospective, randomized, controlled double-blind study of a moisturizer for xerosis of the feet in patients with diabetes. *Ostomy Wound Manage* 2002;48(5):30–6.
157. Jennings MB, Logan L, Alfieri DM et al. A comparative study of lactic acid 10% and ammonium lactate 12% lotion in the treatment of foot xerosis. *J Am Podiatr Med Assoc* 2002;92(3):143–8.
158. Ademola J, Frazier C, Kim SJ et al. Clinical evaluation of 40% urea and 12% ammonium lactate in the treatment of xerosis. *Am J Clin Dermatol* 2002;3:217–22.
159. Uy JJ, Joyce AM, Nelson JP et al. Ammonium lactate 12% lotion versus a liposome-based moisturizing lotion for plantar xerosis. A double-blind comparison study. *J Am Podiatr Med Assoc* 1999;89(10):502–5.
160. Jennings MB, Alfieri D, Ward K et al. Comparison of salicylic acid and urea versus ammonium lactate for the treatment of foot xerosis. A randomized, double-blind, clinical study. *J Am Podiatr Med Assoc* 1998;88(7):332–6.
161. Siskin SB, Quinlan PJ, Finkelstein MS et al. The effects of ammonium lactate 12% lotion versus no therapy in the treatment of dry skin of the heels. *Int J Dermatol* 1993;32(12):905–7.
162. Baillie ATK, Berman JM, Grimaldi CB et al. General practitioner research group. Carbamide in hyperkeratosis. Report no 179. *Practitioner* 1973;294–6.
163. Wehr R, Krochmal L, Bagatell F et al. A controlled two-center study of lactate 12% lotion and a petrolatum-based creme in patients with xerosis. *Cutis* 1986;37:205–9.
164. Rogers RS, Callen J, Wehr R et al. Comparative efficacy of 12% ammonium lactate lotion and 5% lactic acid lotion in the treatment of moderate to severe xerosis. *J Am Acad Dermatol* 1989;21:714–6.
165. Dahl MV, Dahl AC. 12% lactate lotion for the treatment of xerosis. *Arch Dermatol* 1983;119:27–30.
166. Wehr RF, Kantor I, Jones EL et al. A controlled comparative efficacy study of 5% ammonium lactate lotion versus an emollient control lotion in the treatment of moderate xerosis. *J Am Acad Dermatol* 1991;25:849–51.
167. Middleton JD, Roberts ME. Effect of a skin cream containing the sodium salt of pyrrolidone carboxylic acid on dry and flaky skin. *J Soc Cosmet Chem* 1978;29:201–5.
168. Schölermann A, Banké-Bochita J, Bohnsack K et al. Efficacy and safety of Eucerin 10% urea lotion in the treatment of symptoms of aged skin. *J Dermatol Treat* 1998;9:175–9.
169. Frithz A. Investigation of Cortesal®, a hydrocortisone cream and its water-retaining cream base in the treatment of xerotic skin and dry eczemas. *Curr Ther Res* 1983;33:930–5.
170. Palmer CN, Irvine AD, Terron-Kwiatkowski A et al. Common loss-of-function variants of the epidermal barrier protein filaggrin are a major predisposing factor for atopic dermatitis. *Nat Genet* 2006;38(4):441–6.
171. Weidinger S, Illig T, Baurecht H et al. Loss-of-function variations within the filaggrin gene predispose for atopic dermatitis with allergic sensitizations. *J Allergy Clin Immunol* 2006;118(1):214–9.
172. Hoare C, Li Wan Po A, Williams H. Systematic review of treatments for atopic eczema. *Health Technol Assess* 2000;4(37):1–191.
173. Giordano-Labadie F, Cambazard F, Guillet G et al. Evaluation of a new moisturizer (Exomega milk) in children with atopic dermatitis. *J Dermatol Treat* 2006;17(2):78–81.
174. Draelos ZD. The effect of ceramide-containing skin care products on eczema resolution duration. *Cutis* 2008;81(1):87–91.

175. Szczepanowska J, Reich A, Szepietowski JC. Emollients improve treatment results with topical corticosteroids in childhood atopic dermatitis: A randomized comparative study. *Pediatr Allergy Immunol* 2008;19:614–8.
176. Burr S. Emollients for managing dry skin conditions. *Prof Nurse* 1999;15(1):43–8.
177. Lewis-Jones S, Muggleston MA. Management of atopic eczema in children aged up to 12 years: Summary of NICE guidance. *BMJ* 2007;335(7632):1263–4.
178. Lodén M, Bárány E, Mandahl P et al. The influence of urea treatment on skin susceptibility to surfactant-induced irritation: A placebo-controlled and randomized study. *Exogen Dermatol* 2004;3:1–6.
179. Lodén M, Andersson A-C, Lindberg M. Improvement in skin barrier function in patients with atopic dermatitis after treatment with a moisturizing cream (Canoderm®). *Br J Dermatol* 1999;140:264–7.
180. Kuzmina N, Nyrén M, Lodén M et al. Effects of pretreatment with a urea-containing emollient on nickel allergic skin reactions. *Acta Derm Venereol* 2005;85:9–12.
181. Buraczewska I, Berne B, Lindberg M et al. Long-term treatment with moisturizers affects the mRNA levels of genes involved in keratinocyte differentiation and desquamation. *Arch Dermatol Res* 2009;301:175–81.
182. Elias PM, Hatano Y, Williams ML. Basis for the barrier abnormality in atopic dermatitis: Outside-inside-outside pathogenic mechanisms. *J Allergy Clin Immunol* 2008;121(6):1337–43.
183. Lucky AW, Leach AD, Laskarzewski P et al. Use of an emollient as a steroid-sparing agent in the treatment of mild to moderate atopic dermatitis in children. *Pediatr Dermatol* 1997;14(4):321–4.
184. Wirén K, Nohlgård C, Nyberg F et al. Treatment with a barrier-strengthening moisturizing cream delays relapse of atopic dermatitis: A prospective and randomized controlled clinical trial. *J Eur Acad Dermatol Venereol* 2009;23(11):1267–72.
185. Loden M, Wiren K, Smerud K et al. Treatment with a barrier-strengthening moisturizer prevents relapse of hand-eczema. An open, randomized, prospective, parallel group study. *Acta Derm Venereol* 2010;90(6):602–6.
186. Gollnick H, Kaufmann R, Stough D et al. Pimecrolimus cream 1% in the long-term management of adult atopic dermatitis: Prevention of flare progression. A randomized controlled trial. *Br J Dermatol* 2008;158(5):1083–93.
187. Meurer M, Folster-Holst R, Wozel G et al. Pimecrolimus cream in the long-term management of atopic dermatitis in adults: A six-month study. *Dermatology* 2002;205(3):271–7.
188. Wollenberg A, Reitamo S, Girolomoni G et al. Proactive treatment of atopic dermatitis in adults with 0.1% tacrolimus ointment. *Allergy* 2008;63(7):742–50.
189. Meurer M, Fartasch M, Albrecht G et al. Long-term efficacy and safety of pimecrolimus cream 1% in adults with moderate atopic dermatitis. *Dermatology* 2004;208(4):365–72.
190. Berth-Jones J, Damstra RJ, Golsch S et al. Twice weekly fluticasone propionate added to emollient maintenance treatment to reduce risk of relapse in atopic dermatitis: Randomised, double blind, parallel group study. *BMJ* 2003;326(7403):1367.
191. Lund CH, Kuller J, Raines DA et al. *Neonatal skin care—Evidence-based clinical practice guideline*, 2nd edition. Washington, DC: Association of Women’s Health, Obstetric and Neonatal Nurses and the National Association of Neonatal Nurses; 2007.
192. Blume-Peytavi U, Cork MJ, Faergemann J et al. Bathing and cleansing in newborns from day 1 to first year of life: Recommendations from a European round table meeting. *J Eur Acad Dermatol Venereol* 2009;23(7):751–9.
193. Walker L, Downe S, Gomez L. Skin care in the well term newborn: Two systematic reviews. *Birth* 2005;32(3):224–8.
194. National Collaborating Centre for Women’s and Children’s Health. Atopic eczema in children. Management of atopic eczema in children from birth up to the age of 12 years. <http://www.nice.org.uk/nicemedia/pdf/CG057FullGuideline.pdf> 2007.
195. Broberg A, Svensson Å, Borres MP et al. Atopic dermatitis in 5–6-year-old Swedish children: Cumulative incidence, point prevalence, and severity scoring. *Allergy* 2000;55:1025–9.
196. Garcia Bartels N, Scheufele R, Prosch F et al. Effect of standardized skin care regimens on neonatal skin barrier function in different body areas. *Pediatr Dermatol* 2010;27(1):1–8.
197. Chiang C, Eichenfield LF. Quantitative assessment of combination bathing and moisturizing regimens on skin hydration in atopic dermatitis. *Pediatr Dermatol* 2009;26(3):273–8.
198. Garcia Bartels N, Rosler S, Martus P et al. Effect of baby swimming and baby lotion on the skin barrier of infants aged 3–6 months. *J Dtsch Dermatol Ges* 2011;9(12):1018–25.

199. Nopper AJ, Horii KA, Sookdeo-Drost S et al. Topical ointment therapy benefits premature infants. *J Pediatr* 1996;128(5 Pt 1):660–9.
200. Pabst RC, Starr KP, Qaiyumi S et al. The effect of application of aquaphor on skin condition, fluid requirements, and bacterial colonization in very low birth weight infants. *J Perinatol* 1999;19(4):278–83.
201. Brandon DH, Coe K, Hudson-Barr D et al. Effectiveness of No-Sting skin protectant and Aquaphor on water loss and skin integrity in premature infants. *J Perinatol* 2010;30(6):414–9.
202. Beeram M, Olvera R, Krauss D et al. Effects of topical emollient therapy on infants at or less than 27 weeks' gestation. *J Natl Med Assoc* 2006;98(2):261–4.
203. Chamlin SL, Kao J, Frieden IJ et al. Ceramide-dominant barrier repair lipids alleviate childhood atopic dermatitis: Changes in barrier function provide a sensitive indicator of disease activity. *J Am Acad Dermatol* 2002;47(2):198–208.
204. Rendell ME, Baig-Lewis SF, Berry TM et al. Do early skin care practices alter the risk of atopic dermatitis? A case-control study. *Pediatr Dermatol* 2011;28(5):593–5.
205. Simpson EL, Berry TM, Brown PA et al. A pilot study of emollient therapy for the primary prevention of atopic dermatitis. *J Am Acad Dermatol* 2010;63(4):587–93.
206. Lowe AJ, Tang ML, Dharmage SC et al. A phase I study of daily treatment with a ceramide-dominant triple lipid mixture commencing in neonates. *BMC Dermatol* 2012;12(1):3.
207. Udompataikul M, Limpa-o-vart D. Comparative trial of 5% dexpanthenol in water-in-oil formulation with 1% hydrocortisone ointment in the treatment of childhood atopic dermatitis: A pilot study. *J Drugs Dermatol* 2012;11(3):366–74.
208. De Belilovsky C, Roo-Rodriguez E, Baudouin C et al. Natural peroxisome proliferator-activated receptor-alpha agonist cream demonstrates similar therapeutic response to topical steroids in atopic dermatitis. *J Dermatolog Treat* 2011;22(6):359–65.
209. Blanchet-Bardon C, Tadini G, Machado Matos M et al. Association of glycerol and paraffin in the treatment of ichthyosis in children: An international, multicentric, randomized, controlled, double-blind study. *J Eur Acad Dermatol Venereol* 2011.
210. Simpson E, Dutronc Y. A new body moisturizer increases skin hydration and improves atopic dermatitis symptoms among children and adults. *J Drugs Dermatol* 2011;10(7):744–9.
211. Frankel A, Sohn A, Patel RV et al. Bilateral comparison study of pimecrolimus cream 1% and a ceramide-hyaluronic acid emollient foam in the treatment of patients with atopic dermatitis. *J Drugs Dermatol* 2011;10(6):666–72.
212. Hon KL, Wang SS, Lau Z et al. Pseudoceramide for childhood eczema: Does it work? *Hong Kong Med J* 2011;17(2):132–6.
213. Udompataikul M, Srisatwaja W. Comparative trial of moisturizer containing licochalcone A vs. hydrocortisone lotion in the treatment of childhood atopic dermatitis: A pilot study. *J Eur Acad Dermatol Venereol* 2011;25(6):660–5.
214. Miller DW, Koch SB, Yentzer BA et al. An over-the-counter moisturizer is as clinically effective as, and more cost-effective than, prescription barrier creams in the treatment of children with mild-to-moderate atopic dermatitis: A randomized, controlled trial. *J Drugs Dermatol* 2011;10(5):531–7.
215. Tadini G, Giustini S, Milani M. Efficacy of topical 10% urea-based lotion in patients with ichthyosis vulgaris: A two-center, randomized, controlled, single-blind, right-vs.-left study in comparison with standard glycerol-based emollient cream. *Curr Med Res Opin* 2011;27(12):2279–84.
216. Korting HC, Schollmann C, Cholcha W et al. Efficacy and tolerability of pale sulfonated shale oil cream 4% in the treatment of mild to moderate atopic eczema in children: A multicentre, randomized vehicle-controlled trial. *J Eur Acad Dermatol Venereol* 2010;24(10):1176–82.
217. Na JI, Hwang JS, Park HJ et al. A new moisturizer containing physiologic lipid granules alleviates atopic dermatitis. *J Dermatolog Treat* 2010;21(1):23–7.
218. Eichenfield LF, McCollum A, Msika P. The benefits of sunflower oleodistillate (SOD) in pediatric dermatology. *Pediatr Dermatol* 2009;26(6):669–75.
219. Kiechl-Kohlendorfer U, Berger C, Inzinger R. The effect of daily treatment with an olive oil/lanolin emollient on skin integrity in preterm infants: A randomized controlled trial. *Pediatr Dermatol* 2008;25(2):174–8.
220. Msika P, De Belilovsky C, Piccardi N et al. New emollient with topical corticosteroid-sparing effect in treatment of childhood atopic dermatitis: SCORAD and quality of life improvement. *Pediatr Dermatol* 2008;25(6):606–12.

221. Eberlein B, Eicke C, Reinhardt HW et al. Adjuvant treatment of atopic eczema: Assessment of an emollient containing N-palmitoylethanolamine (ATOPA study). *J Eur Acad Dermatol Venereol* 2008;22(1):73–82.
222. Grimalt R, Mengeaud V, Cambazard F. The steroid-sparing effect of an emollient therapy in infants with atopic dermatitis: A randomized controlled study. *Dermatology* 2007;214(1):61–7.
223. Matsumoto T, Yuasa H, Kai R et al. Skin capacitance in normal and atopic infants, and effects of moisturizers on atopic skin. *J Dermatol* 2007;34(7):447–50.
224. Norrman G, Tomicic S, Bottcher MF et al. Significant improvement of eczema with skin care and food elimination in small children. *Acta Paediatr* 2005;94(10):1384–8.
225. Stainer R, Matthews S, Arshad SH et al. Efficacy and acceptability of a new topical skin lotion of sodium cromoglicate (Altoderm) in atopic dermatitis in children aged 2–12 years: A double-blind, randomized, placebo-controlled trial. *Br J Dermatol* 2005;152(2):334–41.
226. Muzaffar F, Hussain I, Rani Z et al. Emollients as an adjunct therapy to topical corticosteroids in children with mild to moderate Atopic Dermatitis. *J Pak Assoc Derma* 2002;2(2):64–8.
227. Lane AT, Drost SS. Effects of repeated application of emollient cream to premature neonates' skin. *Pediatrics* 1993;92(3):415–9.

Cosmeceutical Treatments of the Nail

Alexandra R. Vaughn and Raja K. Sivamani

The human nail unit protects the fingers and toes, amplifies fine touch, and acts as a mechanical tool in manipulating small objects, scratching, and dexterity. Additionally, nails are cosmetically important and contribute a large portion to the beauty industry in improving their appearance and quality. There are multiple cosmeceutical treatments available for brittle nails and other common nail disorders, including biotin, specially formulated nail lacquer, and other vitamins and minerals.¹

Anatomy of the Nail Unit

The nail unit consists of four epithelial structures: proximal nail fold (PNF), matrix, nail bed, and the hyponychium² (Figures 20.1 and 20.2). What is typically called the nail (the nail plate) is derived from basal cells of the nail matrix and forms the rigid “free end” of the nail unit. The cuticle forms the superficial layer of the proximal nail fold. The most important structure of the nail unit is the matrix, which is bordered distally by the nail bed and ventrally by the PNF. The matrix is the germinative epithelium which gives rise to the mature cells of the nail plate. The matrix is firmly attached to its underlying dermal papilla via interdigitating villous structures and anchoring filaments that link to collagen in the dermis. The nail bed starts at the lanula or distal end of the matrix and extends to the hyponychium at the distal finger. The nail bed lies immediately beneath the nail plate and has a markedly decreased cell turnover compared to the matrix. Extending from the distal edge of the nail bed to the terminal nail groove at the free edge of the nail plate is a small zone of epidermis called the hyponychium. The hyponychium is critical in protecting the nail unit from invading microbes and foreign objects. Together, the structures of the nail unit operate as a functional entity with the underlying digital skin, terminal interphalangeal joint, ligaments and tendons, and nerves and vascular supply.

Nail Disorders

Ideally, a fingernail should be longer than it is wide and relatively translucent, with a soft pink color due to the rich vascularity of the underlying nail bed. Some measures to assess nail beauty include shape, color, size, sheen, surface evenness, thickness, and integrity of surrounding tissue. Unfortunately, with age and common nail disorders, the nail plate may form longitudinal ridges, discoloration, and loss of normal consistency, resulting in an aesthetically displeasing appearance.

Brittle Nails

Brittle nails are illustrated by increased fragility of the nail plate. Brittle nails affect over 20% of the population, with double the prevalence in women than in men.³ Nail brittleness may result from normal aging or pathogenic changes in the nail plate and underlying nail matrix. Lack of adhesion between corneocytes in the nail plate and disruption of normal nail formation at the level of the matrix may lead to brittle nails.⁴

Onychoschezia

Onychoschezia is a common disorder in which there is horizontal lamellar splitting of the distal edge of the nail plate. Most theoretical causes include environmental factors with repeated hydration and drying.⁵

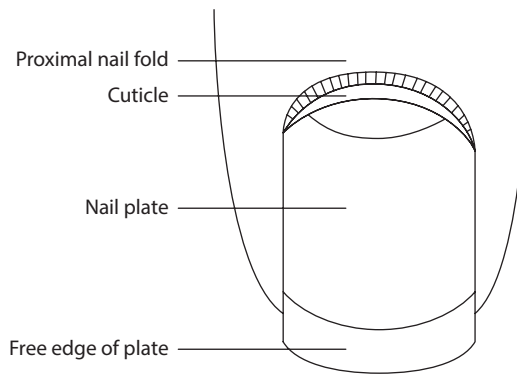

FIGURE 20.1 Dorsal view of the nail.

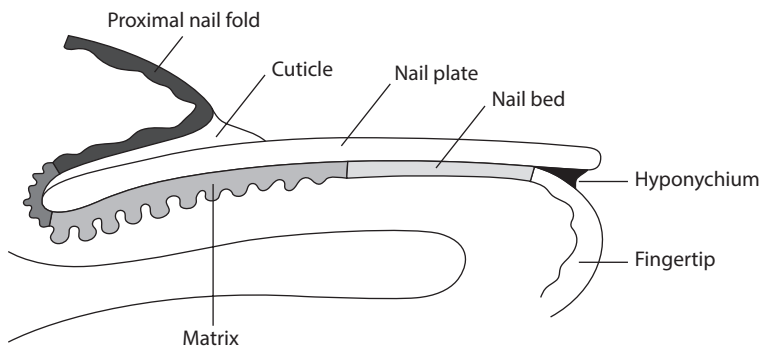

FIGURE 20.2 Cross-sectional view of the nail.

Onycholysis

Onycholysis occurs when the distal nail plate separates from the nail bed beneath it.⁶ This is caused predominately by exogenous factors such as trauma, chemicals, microbes, and drugs; but can also be caused by endogenous factors including psoriasis, dermatitis, neoplastic diseases, and chronic systemic diseases.⁷

Cosmeceutical Treatments

Different formulations available for nail treatment include a broad array of vitamins, minerals, sulfur-containing proteins, and specially formulated topical lacquers. The role of these ingredients in improving various nail conditions is not conclusive. However, several studies have been completed that provide some evidence for their beneficial effects (see [Table 20.1](#)).

Biotin

Several clinical studies offer evidence that oral biotin supplementation may benefit patients suffering from brittle nails. Keratin is a fibrous protein that gives nails structure. Although biotin's definitive mechanism in improving nail health has not been established, it may strengthen nails by stimulating the differentiation of epidermal cells, increasing the amount of keratin matrix proteins in nails, and even increasing nail growth rate.^{8,9} Several studies in patients taking daily oral biotin demonstrated significant improvement in nail thickness and lamellar splitting.^{10–13} Current therapeutic doses for biotin supplementation to improve brittle nails fall in the range of 2.5–10 mg per day.

TABLE 20.1

Cosmeceutical Therapies of the Nail

Cosmeceutical	Study Design	Outcome	Reference
Biotin	Blinded, randomized study using scanning electron microscopy to examine the effects of biotin in eight women with brittle nails who were given 2.5 mg biotin per day for 6–9 months.	25% increase in nail plate thickness in patients with brittle nails who received biotin supplementation and improvement in lamellar splitting in all patients.	10
	Small, retrospective study of biotin (2.5 mg/d) effects for 1.5–7 months in 35 patients with brittle nails.	Clinical improvement in brittle nails in 67% of the patients.	13
	71 patients were treated with a daily oral dose of biotin of 2.5 mg.	91% showed definite improvement with firmer and harder fingernails after an average treatment of 5.5 ± 2.3 months. Biotin in most of the cases provides an effective therapy also for human patients with brittle nails.	11
	Placebo-controlled double blind clinical study.	Significant improvement as a treatment for brittle nails.	12
Calcium	Supplementation with calcium/primrose oil/fish oil compared against calcium only supplementation over 1 year by pre- and postmenopausal women.	Improved nail quality was noted in both pre- and post-menopausal women. No difference was found between treatment groups.	24
<i>Equisetum arvense</i> extract (nail laquer)	Study One: 36 women with nail alterations applied the laquer on one hand only for 28 days.	Study One: significant reduction in longitudinal ridges and 85% decrease in lamellar splitting.	17
	Study Two: 22 women with nail alterations applied the laquer randomly to one hand on alternating days for 14 days. A common nail polish was then applied to both hands and removed by an organic solvent before new product application.	Study Two: significant decrease in lamellar splitting in 82% of cases, significant reduction in nail fragility, and longitudinal grooves were significantly decreased by 28%.	
	A randomized, double-blind, placebo controlled, parallel-group trial was carried out to evaluate the efficacy of a hydrosoluble nail lacquer containing HPCH, <i>Equisetum arvense</i> on nail psoriasis. The test product or a placebo was applied once daily for 24 weeks to all fingernails.	After 24 weeks, the clinical cure rate was 55% in the treatment group and 32% in the placebo group.	19
Iron	40 healthy subjects, five iron-deficient subjects before and during iron supplementation, four patients at various stages of treatment with iron, and 15 postmortem cases were studied. The iron status of the individual was reflected by the amount of iron present in nail samples.	Improvement in brittle nails with iron supplementation, even in subjects without iron deficiency.	26
Pyridoxine and ascorbic acid	Lack of scientific evidence for these vitamins on nail quality.		20

TABLE 20.1 (Continued)

Cosmeceutical Therapies of the Nail

Cosmeceutical	Study Design	Outcome	Reference
			<i>(Continued)</i>
Selenium	Selenium levels were low in four children receiving long-term total parenteral nutrition (TPN). These subjects were treated with 6–12 months of selenium therapy.	Selenium supplementation significantly strengthened the nails in two subjects that were noted to have nail weakness prior to supplementation. No change in nail strength noted in other two subjects.	29
Silica	Open study of women's brittle nails were treated orally with 10 mL colloidal silicic acid (Silicol) once per day for 90 days.	Improvement of brittle nails and improvement in psoriatic nail changes in 5 of 10 patients.	31
	Randomized, double-blind study, patients with psoriatic onychopathy were treated with 30 mL colloidal silicic orally and topically with the same gel for 3 months.	Psoriatic nail changes were improved in 5 of 10 patients.	32
Sulfur-containing amino acids and proteins		Cystine may have a positive effect on growth of hyponychium.	23
Thiamine	Double-blind placebo controlled study evaluating efficacy of thiamine-containing compound Pantovigar® claimed to improve nail quality.	No proven beneficial effect on nail growth or quality.	33
Vitamin E (ingested)	Open trial studying high doses between 600 and 1200 EU daily of ingested vitamin E for many months.	Success in the treatment of yellow nail syndrome.	21
Vitamin E (topical)	A double-blind controlled study was performed on a patient with long-standing yellow nail syndrome to investigate the potential beneficial role of topical vitamin E solution for the nail changes seen in this disorder.	The nails treated with active solution showed significant clinical improvement in symptoms of yellow nail syndrome and increase in nail growth rates after 6 months.	22

Genadur Nail Laquer Containing Equisetum Arvense Extract

A specially formulated nail lacquer has been evaluated for improving nail strength and integrity in patients suffering from nail fragility and splitting. This lacquer consists of a plant extract from *Equisetum arvense*, a sulfur donor group, and a film-forming agent called hydroxyl-propyl Chitosan (HPCH). *Equisetum arvense* contains organic silica, which has been established to make the nail stronger and harder.¹⁴ The sulfur donor group supports nail growth and integrity.¹⁵ The chitosan derivative (HPCH) acts as a film-forming agent to increase nail hydration and significantly improve delivery of the active ingredients to the nails.¹⁶ Two clinical studies showed significant reduction in longitudinal nail grooves, nail fragility, and lamellar splitting¹⁷ and in psoriasis-related nail onychodystrophy.¹⁸ A randomized, double-blinded study established the efficacy of this HPCH-based nail lacquer compared to a placebo in the improvement in their nail psoriasis with 55% achieving clinical cure at 24 weeks as compared to 32% in the placebo group.¹⁹

Pyridoxine and Ascorbic Acid

A combination of daily pyridoxine (25–30 mg), vitamin C (2–3 g), and evening primrose oil (two capsules three times per day) has been recommended to treat brittle nails; however, there is no scientific evidence to support their beneficial effects on nail quality.²⁰

Vitamin E

Vitamin E has demonstrated some success in the treatment of yellow nail syndrome when taken orally (600 EU to 1200 EU daily) for several months.²¹ Topically-applied vitamin E has also shown significant improvement in symptoms of yellow nail syndrome, as well as increased nail growth rates after six months.²²

Sulfur-Containing Proteins

Nails are lush in sulfur, making sulfur-rich proteins and amino acids an attractive treatment for the improvement of nail quality.⁹ Although sulfur itself has not been proven to improve nail quality, the amino acid cysteine may increase hyponychium growth.²³

Calcium

In a study of pre-menopausal and post-menopausal women, all were given a daily 1.0 g dose of calcium (along with 4.0 g of evening primrose oil and 440 mg fish oil). After one year of calcium supplementation, there was overall improvement in the nail quality of the pre- and post-menopausal women, although there were no significant differences between the treatment group and those supplemented solely with calcium.²⁴ The nail composition is relatively poor in calcium, therefore it is unclear what role calcium supplementation plays in improving nail hardness.²⁵

Iron

The iron content in the nail can be measured to reflect the iron content of the individual. In a study of healthy and iron-deficient subjects, iron supplementation improved brittle nails, even in subjects without iron deficiency.²⁶

Zinc

Zinc deficiency has been shown to cause fragile nails with longitudinal ridges and discoloration. Zinc supplementation may activate nail growth in deficient individuals.²⁷

Selenium

The body requires selenium in order for the enzyme glutathione peroxidase to protect against DNA oxidation. In rats, nail composition reflects the total body levels of selenium,²⁸ although it is unclear if this is true in humans as well. In two patients demonstrating nail weakness in the setting of selenium deficiency due to dependence on total parenteral nutrition, supplementation improved nail strength.²⁹ The method in assessing nail strength was not reported. A controlled study evaluating the role of selenium in nail strength is still needed. Additionally, selenium toxicity has been said to lead to nail loss, fingertip swelling, and purulent discharge.³⁰

Silica

Silica makes up roughly 0.016% of the nail composition and it is claimed to assist in keratin cross-linking, which would improve nail firmness. This claim was demonstrated in a study in which women received 10 mL of colloidal silicic acid once per day for 90 days and had significant improvement in their brittle nails.³¹ Additionally, silicic acid improved psoriatic nail changes in 5 of 10 patients.³²

Conclusion

Cosmetically displeasing nail disorders may be treatable using several cosmeceuticals. Some ingredients, such as biotin and nail lacquer containing *Equisetum arvense* extract, offer more evidence for improvement in nail quality, while other ingredients require more thorough clinical studies to examine their efficacy. Prior to initiating any cosmeceutical therapies, systemic disease and infections must be ruled out. Careful inspection of the nail is essential in selecting the most appropriate therapy.

REFERENCES

1. Haneke E. Onychocosmeceuticals. *J Cosmet Dermatol* 2006;5(1):95–100.
2. Zaia N. *The Nail in Health and Disease*, 2nd edn. Norwalk, CT: Appleton & Lange; 1990.
3. Lubach D, Cohrs W, Wurzinger R. Incidence of brittle nails. *Dermatologica* 1986;172(3):144–7.
4. Uyttendaele H, Geyer A, Scher RK. Brittle nails: Pathogenesis and treatment. *J Drugs Dermatol* 2003;2(1):48–9.
5. Wallis MS, Bowen WR, Guin JD. Pathogenesis of onychoschizia (lamellar dystrophy). *J Am Acad Dermatol* 1991;24(1):44–8.
6. Kechijian P. Onycholysis of the fingernails: Evaluation and management. *J Am Acad Dermatol* 1985;12(3):552–60.
7. Scher R, Daniel CR. *Nails: Therapy, Diagnosis, Surgery*. Philadelphia, PA: WB Saunders; 1990.
8. Schmidt K. Comparison of operating mechanism of different ingredients for treatment of brittle nails [in German]. *Z Hautkr* 1993;68:517–20.
9. Runne U, Orfanos CE. The human nail: Structure, growth and pathological changes. *Curr Probl Dermatol* 1981;9:102–49.
10. Colombo VE, Gerber F, Bronhofer M, Floersheim GL. Treatment of brittle fingernails and onychoschizia with biotin: Scanning electron microscopy. *J Am Acad Dermatol* 1990;23(6 Pt 1):1127–32.
11. Floersheim GL. Treatment of brittle fingernails with biotin. *Z Hautkr* 1989;64(1):41–8 (in German).
12. Gehring W. Effect of biotin on poor nail quality: A placebo-controlled double-blind clinical study. *Akt Dermatol* 1996;22:20–5 (in German).
13. Hochman LG, Scher RK, Meyerson MS. Brittle nails: Response to daily biotin supplementation. *Cutis* 1993;51(4):303–5.
14. Holzhter G, Narayanan K, Gerber T. Structure of silica in *Equisetum arvense*. *Anal Bioanal Chem* 2003;376(4):512–7.
15. Parcell S. Sulfur in human nutrition and applications in medicine. *Altern Med Rev* 2002;7(1):22–44.
16. Monti D, Saccomani L, Chetoni P, Burgalassi S, Sættonen MF, Mailland F. In vitro transungual permeation of ciclopirox from a hydroxypropyl chitosan-based, water-soluble nail lacquer. *Drug Dev Ind Pharm* 2005;31(1):11–7.

17. Sparavigna A, Setaro M, Genet M, Frisenda L. Equisetum arvense in a new transungual technology improves nail structure and appearance. *J Plast. Dermatol* 2006;2(1):31–8.
18. Cantoresi F, Sorgi P, Arcese A, Bidoli A, Bruni F, Carnevale C, Calvieri S. Improvement of psoriatic onychodystrophy by a water-soluble nail lacquer. *J Eur Acad Dermatol Venereol* 2009;23(7):832–4.
19. Cantoresi F, Caserini M, Bidoli A, Maggio F, Marino R, Carnevale C, Sorgi P, Palmieri R. Randomized controlled trial of a water-soluble nail lacquer based on hydroxypropyl-chitosan (HPCH), in the management of nail psoriasis. *Clin Cosmet Investig Dermatol* 2014;7:185–90.
20. Campbell AJ, McEwan GC. Treatment of brittle nails and dry eyes. *Br J Dermatol* 1981;105(1):113.
21. Norton L. Further observations on the yellow nail syndrome with therapeutic effects of oral alpha-tocopherol. *Cutis* 1985;36(6):457–62.
22. Williams HC, Buffham R, du Vivier A. Successful use of topical vitamin E solution in the treatment of nail changes in yellow nail syndrome. *Arch Dermatol* 1991;127(7):1023–8.
23. Schmiegelow PG, Berndt G, Linder J, Puschmann M. Quantitative autoradiographische Untersuchungen an Haaren. Haut und Nageln mit den Vorlaufnern 36S-Cystin bzw. 35S-Methionin und 3H-Thymidin im Tierexperiment. *Therapiewoche* 1981;31:8453–60.
24. Bassey EJ, Littlewood JJ, Rothwell MC, Pye DW. Lack of effect of supplementation with essential fatty acids on bone mineral density in healthy pre- and postmenopausal women: Two randomized controlled trials of Efacal v. calcium alone. *Br J Nutr* 2000;83(6):629–35.
25. Forslind B. Biophysical studies of the normal nail. *Acta Derm Venereol* 1970;50(3):161–8.
26. Sobolewski S, Lawrence AC, Bagshaw P. Human nails and body iron. *J Clin Pathol* 1978;31(11):1068–72.
27. Weismann K. Lines of Beau: Possible markers of zinc deficiency. *Acta Derm Venereol* 1977;57(1):88–90.
28. Behne D, Gessner H, Kyriakopoulos A. Information on the selenium status of several body compartments of rats from the selenium concentrations in blood fractions, hair and nails. *J Trace Elem Med Biol* 1996;10(3):174–9.
29. Vinton NE, Dahlstrom KA, Strobel CT, Ament ME. Macrocytosis and pseudoalbinism: Manifestations of selenium deficiency. *J Pediatr* 1987;111(5):711–7.
30. Janssen R, Closson W. Selenium intoxication. *J Am Med Assoc* 1984;251:1938.
31. Lassus A. Colloidal silicic acid for oral and topical treatment of aged skin, fragile hair and brittle nails in females. *J Int Med Res* 1993;21(4):209–15.
32. Lassus A. Colloidal silicic acid for the treatment of psoriatic skin lesions, arthropathy and onychopathy. A pilot study. *J Int Med Res* 1997;25(4):206–9.
33. Petri H, Pierchalla P, Tronnier H. The efficacy of drug therapy in structural lesions of the hair and in diffuse effluvium—comparative double blind study. *Schweiz Rundsch Med Prax* 1990;79(47):1457–62.

21

Botanicals and Cosmeceuticals for Sun Protection

William Tuong, Sandy Kuo, and Raja K. Sivamani

Introduction

Botanical extracts may represent an important area of research in the prevention of ultraviolet (UV)-induced skin cancers and aging. UVB radiation includes medium wavelengths ranging between 280 and 320 nm, and UVA light includes longer waves that span between 320 and 400 nm. UVB rays constitute approximately 5% of total solar UV light. They are primarily responsible for sunburn and are an important agent in the development of cancers such as melanoma and non-melanoma skin cancers.¹ Specifically, UVB light acts predominantly on the epidermal basal layer of the skin and has genotoxic effects, including the formation of pyrimidine photoproducts, stimulation of DNA synthesis, free radical production, and cell cycle growth arrest.² In contrast, UVA radiation comprises more than 90% of solar radiation but only accounts for 10% of the carcinogenic dose of sunlight.³ UVA light readily penetrates deeper cutaneous layers and contributes to photoaging through multiple mechanisms, such as reactive oxygen species formation, DNA damage, and induction of inflammation.²

Botanicals may be useful in sunscreen products because certain plant-derived compounds may help absorb UV light and prevent direct damage of cellular targets (Table 21.1). Additionally, they may also inhibit chronic inflammation, modulate UV-induced immunosuppression, induce apoptosis, and possess direct and indirect antioxidant effects.⁴ This chapter will discuss popular botanical compounds and how they may provide photoprotection.

Photoprotective Effect of Botanicals

Lycopene

Lycopene is a red carotenoid compound found in pink grapefruit, papaya, wolfberry, goji, and tomatoes (Figure 21.1).⁵ Dietary supplementation with tomato-based products appears to lower biomarkers of oxidative stress and carcinogenesis.⁶ Limited available evidence from small human intervention studies indicate that lycopene supplementation for 10–12 weeks may decrease UV-induced erythema.⁷ Although the bioavailability of lycopene in raw tomatoes is low due to tight binding with indigestible fiber, lycopene can be released from the food matrix through heating and food processing.⁸

The effect of topical lycopene is not well characterized. An *in vivo* study using SKH-1 hairless mice found that topical lycopene reduced the activity of ornithine decarboxylase (ODC) and myeloperoxidase (MPO), enzymes that have been implicated in the carcinogenic and acute inflammatory effect of UVB irradiation.⁹

Camellia sinensis

Green tea (*Camellia sinensis*) extract contains a mixture of catechins.¹⁰ These polyphenolic compounds are antioxidative due to their ability to stabilize radical anions via hydrogen atom donation.¹¹ In humans, topically applied green tea extract demonstrated a dose-dependent decrease in UV-induced erythema, a decline in the number of sunburn cells, protection of epidermal Langerhans cells, and a

TABLE 21.1

Light Absorbance and Proposed Modes of Action of Cosmeceuticals and Botanicals

Category	Botanical/Cosmeceutical	Extraction Technique vs. Phytochemical	Light Absorbance	Mode of Action Noted in Studies	Reference
Carotenoid	Carotenoid accessory pigments (i.e., lycopene, β -carotene)	Phytochemical	Visible light (450 and 570 nm)	β -Carotene or lycopene in diet protects against UV-induced erythema but protection is considerably lower than that achieved by using topical sunscreens. An optimal supply of antioxidant micronutrients in the skin increases basal dermal defense against UV irradiation, supports longer-term protection, and contributes to maintenance of skin health and appearance.	51
	Phytoene, phytofluene	Phytochemical	UVB, UVA	Phytoene and phytofluene are precursor molecules of higher unsaturated carotenoids and occur in various fruit and vegetables, thus potentially contributing to photoprotective effects of carotenoid-rich food.	51
	Lutein, zeaxanthin	Phytochemical	Blue-light filtering absorption maxima 445–472 nm	Lutein and zeaxanthin found in macular pigment. By absorbing blue-light, the macular pigment protects the underlying photoreceptor cell layer from light damage.	52,53
Alkaloids	Caffeine	Phytochemical and caffeine sodium benzoate	UVB	Topical applications of caffeine or caffeine-SB to UVB-pretreated “high-risk mice” inhibits skin carcinogenesis (keratoacanthomas and squamous cell carcinomas).	16
	Sanguinarine, protopine, chelidonine, allocryptopine, and stylopine	Phytochemical	UVB	Cytotoxicity tests demonstrated selective and profound apoptotic effects of a five-alkaloid combination in the mouse melanoma B16F10 cell line.	54
Polyphenols	Green tea [(–)-epigallocatechin 3-gallate (EGCG), green tea polyphenols]	Ethanol/water	UV light EGCG absorbs at λ_{max} 270–273 nm	Application of green tea extracts resulted in a dose-dependent inhibition of the erythema response evoked by UV radiation. The (–)-epigallocatechin-3-gallate (EGCG) and (–)-epicatechin-3-gallate (ECG) polyphenolic fractions were most efficient at inhibiting erythema, whereas (–)-epigallocatechin (EGC) and (–)-epicatechin (EC) had little effect.	12
	Silymarin	Phytochemical	Not reported	Anti-photocarcinogenic ability mediated through its antioxidant and anti-inflammatory activities in UVB-irradiated skin.	55

(Continued)

TABLE 21.1 (Continued)

Light Absorbance and Proposed Modes of Action of Cosmeceuticals and Botanicals

Category	Botanical/Cosmeceutical	Extraction Technique vs. Phytochemical	Light Absorbance	Mode of Action Noted in Studies	Reference
	<i>Polypodium leucotomes</i>	Not described	Not reported	Inhibits generation of ROS production induced by UV, prevents damage to the DNA, inhibits UV-induced AP1 and NF-κB, and protects endogenous skin natural antioxidant systems. Marked decrease of UV-mediated cellular apoptosis and necrosis and inhibition of extracellular matrix remodeling.	56
	Black tea	Aqueous and ethanol	200–400 nm, peak 250–300 nm	Aqueous extract more effective than ethanolic extract in UVA and UVB absorption. Inclusion into cream showed prevention of erythema formation after UV exposure.	57
	Genistein	Phytochemical	Not reported	Genistein effectively blocked UVB-induced skin burns in humans as well as PUVa-induced photodamage and molecular alterations in hairless mouse skin.	58
	Honeybush extract	Ethanol/acetone	250–400 nm	In UVB-exposed SKH1 mice, there were reduced signs of sunburn, edema, epidermal hyperplasia and the induction of cyclooxygenase-2 (COX-2), ornithine decarboxylase (ODC), GADD45 and OGG1/2 expression.	35
	Pycnogenol (procyanidins, caffeic acid, gallic acid, ferulic acid, protocatechuic acid, vanillic acid)	Dimethyl sulfoxide	275–290 nm	In Skh-1 hairless mice, topical Pycnogenol demonstrated significant and dose-dependent protection from SSUV-induced (UVA + UVB) acute inflammation, immunosuppression and carcinogenesis, when applied to the skin after daily irradiation.	36
	Resveratrol	Phytochemical, oil in water emulsions	290–400 nm <i>trans</i> isomer peak between 304–321 nm <i>cis</i> isomer peak at 286 nm	UV radiation causes <i>trans</i> -resveratrol to undergo photoisomerization and some photodecomposition, leading to reduction in antioxidant activity. However, in the presence of ethylhexylmethoxycrylene, a photostabilizer used in sunscreens, the effects of UV exposure on <i>trans</i> -resveratrol are reduced and improve its antioxidant behavior.	25,26
	Grape seed extract (proanthocyanidins)	Not reported	No absorbance	In SKH-1 hairless mice, dietary supplementation with GSPs is associated with a decrease of UVB-induced skin tumor development in terms of tumor incidence, tumor multiplicity, and a decrease in the malignant transformation of papillomas to carcinomas.	59

(Continued)

TABLE 21.1 (Continued)

Light Absorbance and Proposed Modes of Action of Cosmeceuticals and Botanicals

Category	Botanical/Cosmeceutical	Extraction Technique vs. Phytochemical	Light Absorbance	Mode of Action Noted in Studies	Reference
	Pomegranate fruit extract: anthocyanins (delphinidin, cyanidin, pelargonidin) and hydrolysable tannins (punicalin, pedunculagin, punicalagin)	70% acetone–30% distilled water (1:20, w/v)	No absorbance	In SKH-1 hairless mice, pomegranate fruit extract consumption protected against the adverse effects of UVB radiation by modulating UVB-induced signaling pathways.	60
	Tumeric/curcumin	Encapsulated into nanoparticles consisting of ethyl cellulose and/or methyl cellulose	420 nm	Nanoencapsulation protects curcumin from photo degradation and can therefore prolong the antioxidant activity of curcumin.	61,62
Isothiocyanates	Sulforaphane	Phytochemical	205 nm	A simple solid-phase extraction (SPE) method for the determination of sulforaphane in broccoli has been developed. The optimal conditions were found to be use of a silica SPE cartridge, and ethyl acetate and dichloromethane as washing and eluting solvents.	63
Vitamins	Vitamin A (retinol and retinyl esters)	Retinyl palmitate as 2% oil-in-water cream	300–350 nm, peak 325 nm	In human subjects, topical retinyl palmitate was as efficient as a sun protection factor 20 sunscreen in preventing sunburn erythema as well as the formation of thymine dimers.	64
	Vitamin B3 (nicotinamide)	1:2:1 propylene glycol, ethanol, and distilled water vehicle at a concentration of 5%	No absorbance	Topical nicotinamide prevented immunosuppression, with gene chip microarrays suggesting that the mechanisms of protection may include alterations in complement, energy metabolism, and apoptosis pathways.	65
	Vitamin C (L-ascorbic acid)	Not described	254 nm	Ascorbic acid prevents short wavelength ultraviolet light-induced deamination through absorbance of ultraviolet light rather than through antioxidant mechanisms.	66
	Vitamin E (tocopherols)	5% dispersion in a neutral cream vehicle	UVB, peak 286–296 nm	Tocopherol compounds in sunscreen products protect against procarcinogenic DNA photodamage and cellular uptake and distribution of tocopherol compounds is necessary for their optimal photoprotection.	67

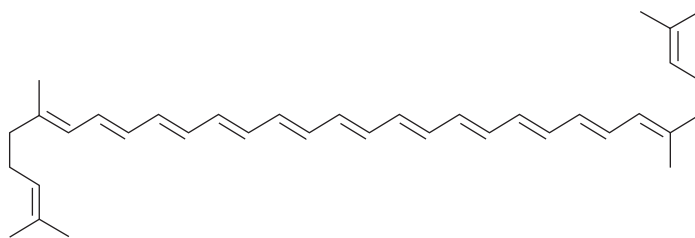

FIGURE 21.1 Lycopene.

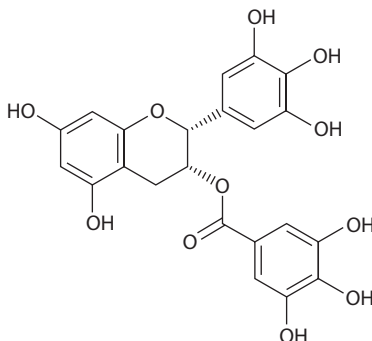

FIGURE 21.2 EGCG.

decrease in DNA damage.¹² Topical application of epigallocatechin-3-gallate (EGCG), a major polyphenolic constituent of green tea (Figure 21.2), may also protect against photocarcinogenesis by preventing UVB-induced immunosuppression.¹³

Caffeine

Caffeine is a purine alkaloid commonly found in coffee and tea (Figure 21.3).¹⁴ Several *in vivo* studies have demonstrated that topical and oral administration of caffeine exerts a photoprotective effect through various mechanisms. Specifically, caffeine has been demonstrated to induce apoptosis in DNA-damaged epidermal cells and tumors while sparing normal tissue. Mouse models demonstrate that this apoptotic effect is secondary to increased expression of wild-type p53, a tumor suppressor gene that is commonly mutated in UV-related skin cancers.^{15,16} Moreover, caffeine also has a sunscreen-like effect and inhibits formation of UVB-induced thymine dimers and sunburn skin lesions.¹⁶

Sanguinaria Canadensis

Sanguinarine is a benzophenanthridine alkaloid derived from the root of *Sanguinaria canadensis* (Figure 21.4). Limited available evidence indicates that it may be used to prevent and treat UV-induced skin damage. Specifically, topical application of sanguinarine on the skin of SKH-1 hairless mice before

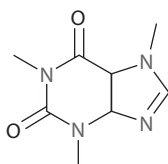

FIGURE 21.3 Caffeine.

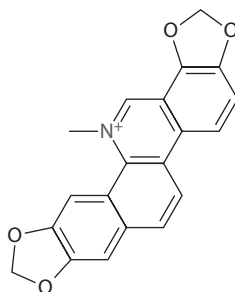

FIGURE 21.4 Sanguinarine.

or after UVB irradiation resulted in significantly lower UVB-mediated skin edema, skin hyperplasia and infiltration of leukocytes, and markers of oxidative stress (e.g., H_2O_2).¹⁷

Silybum marianum

Silybum marianum (milk thistle) contains numerous phytochemicals, such as silymarin and silibinin (Figure 21.5), demonstrating antioxidant and anti-inflammatory activity.¹⁸ Silibinin has strong protection against UV-induced damage by inhibition in both cell proliferation and apoptosis by reducing thymine dimer-positive cells and upregulating p53 in mice.¹⁸ Increasing the transcriptional activity of p53 leads to the synthesis of p21/Cip1, a protein that arrests DNA synthesis and thereby increases DNA repair time.^{19,20}

Polypodium leucotomos

Polypodium leucotomos is a tropical fern extract that may improve systemic photoprotection after oral administration.²¹ Its photoprotective effect is derived from its ability to reduce free radical generation, photodecomposition of both endogenous photoprotective molecules and DNA, and UV-induced cell death.²¹ Several small clinical trials have reported that orally administered *Polypodium leucotomos* decreased UV-induced erythema²² or increased minimal erythema dose.²³ Moreover, histological evaluation demonstrated significantly lower numbers of sun burn cells, cyclobutane pyrimidine dimers, proliferating epidermal cells, and dermal mast cell infiltration after treatment with the fern extract.²²

Resveratrol

Resveratrol can be found in the skins and seeds of grapes and in peanuts (Figure 21.6). It has demonstrated potent antioxidant, anti-inflammatory, and anti-proliferative activities.²⁴ Topical application of resveratrol in mice demonstrated photoprotection by significantly decreasing UVB-mediated generation of hydrogen peroxide and infiltration of leukocytes.²⁵ Its antiproliferative properties are related to the inhibition of cellular events associated with tumor initiation, promotion, and progression, and the triggering of apoptosis in tumor cells.²⁶

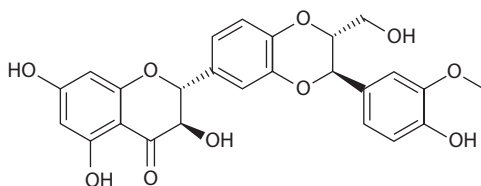

FIGURE 21.5 Silybin A.

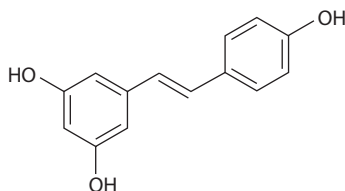

FIGURE 21.6 Resveratrol.

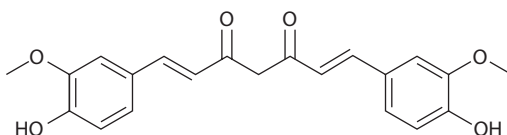

FIGURE 21.7 Curcumin.

Curcumin

Curcumin, the active component of turmeric (*Curcuma longa*), has been regarded as an anti-inflammatory and antioxidant agent (Figure 21.7).²⁷ Particularly, it can scavenge reactive oxygen species, such as hydroxyl radicals, superoxide anion radicals, and nitrogen dioxide radicals.²⁷ Additionally, it serves as an anti-inflammatory by down-regulating the production of pro-inflammatory cytokines (e.g., IL-1 and TNF- α) and inhibiting the activation of specific transcription factors (e.g., NF- κ B and AP-1).²⁸ Curcumin also demonstrates antiproliferative properties.²⁹ Specifically, it inhibits UV radiation-induced skin cancer in SKH-1 hairless mice²⁹ and reduces UVB-induced matrix metalloproteinase-1/3 expression in human dermal fibroblasts via MAPK-p38/JNK pathway suppression.³⁰

Pomegranate

Pomegranate (*Punica granatum*) fruit extract is a rich source of polyphenolic compounds, such as anthocyanins and hydrolyzable tannins.³¹ *In vitro* studies demonstrate that pomegranate fruit extract may serve as a photochemopreventative agent by modulating UV-induced stress-mediated cellular pathways that contribute to skin carcinogenesis.³¹ In particular, pomegranate fruit extract inhibits UV-induced modulations of NF- κ B and MAPK pathways.²⁵

Genistein

Genistein, an isoflavone isolated from soybeans, exhibits anticarcinogenic and antioxidant properties.³² Particularly, genistein has been shown to inhibit production of IL-6 and MAPK.³² Modulation to these cellular events may help regulate and attenuate UVB-induced inflammatory damage to the skin.³² Moreover, genistein inhibits UV-induced oxidative DNA damage and blocks UV-induced expression of c-fos and c-jun proto-oncogenes.^{33,34}

Honeybush

Honeybush (*Cyclopia subternata*) is a type of fynbos plant species that grows exclusively in South Africa. The extract from this plant has been shown to reduce oxidative stress and prevent tumor formation in mice.³⁵ Topically applied honeybush extract reduced signs of UVB-induced erythema and cutaneous scaling in SKH-1 hairless mice.³⁵ Although not fully elucidated, the photoprotective effect of honeybush extracts may be attributed to the modulation of induced-oxidative damage, inflammation, and cell proliferation.³⁵

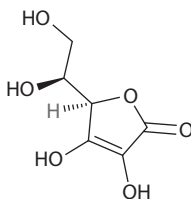

FIGURE 21.8 Vitamin C.

Pycnogenol

Pycnogenol is a standardized maritime pine bark (*Pinus pinaster*) extract primarily comprised of monomeric and oligomeric procyanidins.³⁶ As such, it demonstrates multiple biological effects, such as antioxidant, anti-inflammatory, and anti-carcinogenic properties.³⁶ Specifically, it performs as an anti-oxidant by scavenging for reactive oxygen and nitrogen species.^{37,38} It modulates the expression of proinflammatory cytokines in macrophages to induce an anti-inflammatory effect.³⁹ It has been shown to selectively induce apoptosis within specific human cancer cell lines.⁴⁰

Vitamin C

Vitamin C (L-ascorbic acid) is a water-soluble essential nutrient commonly found in citrus fruits (Figure 21.8). Its antioxidant activity is due to its reduction potential, which prevents UV-induced generation of reactive oxygen.⁴¹ In addition to its antioxidant potential, it also is an important cofactor for several enzymes of collagen synthesis. In animal models, the photoprotective effects of topically administered vitamin C include the reduction of erythema and formation of sunburn cells.⁴² Additionally, topically applied L-ascorbic has been shown to abrogate UV-induced immunosuppression.⁴³

Vitamin E

Vitamin E refers to a group of lipid-soluble antioxidants that includes tocopherols (Figure 21.9) and tocotrienols.⁴⁴ It serves to scavenge for radicals and protect cell membranes from oxidative stress.⁴⁴ Topical vitamin E application has been shown to reduce UVB-induced damage and inhibit photocarcinogenesis.^{45,46} In animal models, oral and topical supplementation has been shown to diminish the effects of photoaging, inhibit the development of skin cancer, and counteract immunosuppression after UV irradiation.^{47,48}

Current Controversies and Conclusions

Although botanical extracts are increasingly used in skincare products, their safety and efficacy profiles remain poorly understood. The general population assumes that botanical compounds are safe because they are plant derived, and many are easily accessed.⁴⁹ However, botanicals may not be safer than

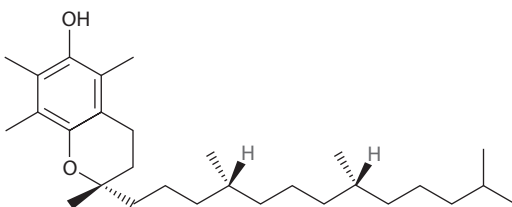

FIGURE 21.9 Alpha tocopherol.

traditional pharmaceutical drugs and can be the source of allergy as well.⁴⁹ In particular, skincare products with botanical extracts may still contain preservatives and fragrance that lead in allergic contact dermatitis in some patients.⁴⁹ Therefore, these products should be assessed for their potential to cause allergy.

Many of the current studies involve testing in cell culture and in animals. Although this provides mechanistic insight, clinical testing with humans is essential and needed. Additionally, it is still not clear if the current use of botanical extracts in skincare products confers additional clinical benefit against UV exposure. It has been previously shown that free radical protection was not increased by the addition of antioxidants to UV filters in sunscreen products.⁵⁰ In fact, free radical protection in the tested products was found to be attributed to the UV filters, and the added antioxidants demonstrated low antioxidant capability *ex vivo*.⁵⁰ Future antioxidant measures may be important to assess the role of the botanical agents in sunscreens. Additional clinical trials are needed to evaluate both the safety and efficacy of botanical compounds for dermatology-specific indications.

REFERENCES

1. Chen AC, Halliday GM, Damian DL. Non-melanoma skin cancer: Carcinogenesis and chemoprevention. *Pathology* 2013;45:331–41.
2. Polefka TG, Meyer TA, Agin PP, Bianchini RJ. Effects of solar radiation on the skin. *J Cosmet Dermatol* 2012;11:134–43.
3. F'Guyer S, Afaq F, Mukhtar H. Photochemoprevention of skin cancer by botanical agents. *Photodermatol Photoimmunol Photomed* 2003;19:56–72.
4. Dinkova-Kostova AT. Phytochemicals as protectors against ultraviolet radiation: Versatility of effects and mechanisms. *Planta Med* 2008;74:1548–59.
5. Wang XD. Lycopene metabolism and its biological significance. *Am J Clin Nutr* 2012;96:1214S–22S.
6. Basu A, Imrhan V. Tomatoes versus lycopene in oxidative stress and carcinogenesis: Conclusions from clinical trials. *Eur J Clin Nutr* 2007;61:295–303.
7. Stahl W, Heinrich U, Aust O, Tronnier H, Sies H. Lycopene-rich products and dietary photoprotection. *Photochem Photobiol Sci* 2006;5:238–42.
8. Gartner C, Stahl W, Sies H. Lycopene is more bioavailable from tomato paste than from fresh tomatoes. *Am J Clin Nutr* 1997;66:116–22.
9. Fazekas Z, Gao D, Saladi RN et al. Protective effects of lycopene against ultraviolet B-induced photo-damage. *Nutr Cancer* 2003;47:181–7.
10. Braicu C, Ladomery MR, Chedea VS, Irimie A, Berindan-Neagoe I. The relationship between the structure and biological actions of green tea catechins. *Food Chem* 2013;141:3282–9.
11. Frei B, Higdon JV. Antioxidant activity of tea polyphenols in vivo: Evidence from animal studies. *J Nutr* 2003;133:3275S–84S.
12. Elmetts CA, Singh D, Tubesing K et al. Cutaneous photoprotection from ultraviolet injury by green tea polyphenols. *J Am Acad Dermatol* 2001;44:425–32.
13. Katiyar SK, Challa A, McCormick TS, Cooper KD, Mukhtar H. Prevention of UVB-induced immunosuppression in mice by the green tea polyphenol (–)-epigallocatechin-3-gallate may be associated with alterations in IL-10 and IL-12 production. *Carcinogenesis* 1999;20:2117–24.
14. Ojeh N, Stojadinovic O, Pastar I et al. The effects of caffeine on wound healing. *Int Wound J* 2014.
15. Lu YP, Lou YR, Li XH et al. Stimulatory effect of oral administration of green tea or caffeine on ultraviolet light-induced increases in epidermal wild-type p53, p21(WAF1/CIP1), and apoptotic sunburn cells in SKH-1 mice. *Cancer Res* 2000;60:4785–91.
16. Lu YP, Lou YR, Xie JG et al. Caffeine and caffeine sodium benzoate have a sunscreen effect, enhance UVB-induced apoptosis, and inhibit UVB-induced skin carcinogenesis in SKH-1 mice. *Carcinogenesis* 2007;28:199–206.
17. Ahsan H, Reagan-Shaw S, Eggert DM et al. Protective effect of sanguinarine on ultraviolet B-mediated damages in SKH-1 hairless mouse skin: Implications for prevention of skin cancer. *Photochem Photobiol* 2007;83:986–93.
18. Dhanalakshmi S, Mallikarjuna GU, Singh RP, Agarwal R. Silibinin prevents ultraviolet radiation-caused skin damages in SKH-1 hairless mice via a decrease in thymine dimer positive cells and an up-regulation of p53-p21/Cip1 in epidermis. *Carcinogenesis* 2004;25:1459–65.

19. Huang LC, Clarkin KC, Wahl GM. Sensitivity and selectivity of the DNA damage sensor responsible for activating p53-dependent G1 arrest. *Proc Natl Acad Sci USA* 1996;93:4827–32.
20. Mullauer L, Gruber P, Sebinger D et al. Mutations in apoptosis genes: A pathogenetic factor for human disease. *Mutat Res* 2001;488:211–31.
21. Gonzalez S, Alonso-Lebrero JL, Del Rio R, Jaen P. *Polypodium leucotomos* extract: A nutraceutical with photoprotective properties. *Drugs Today (Barc)* 2007;43:475–85.
22. Middelkamp-Hup MA, Pathak MA, Parrado C et al. Oral *Polypodium leucotomos* extract decreases ultraviolet-induced damage of human skin. *J Am Acad Dermatol* 2004;51:910–8.
23. Aguilera P, Carrera C, Puig-Butille JA et al. Benefits of oral *Polypodium leucotomos* extract in MM high-risk patients. *J Eur Acad Dermatol Venereol* 2013;27:1095–100.
24. Pangen R, Sahni JK, Ali J, Sharma S, Baboota S. Resveratrol: Review on therapeutic potential and recent advances in drug delivery. *Expert Opin Drug Deliv* 2014;11:1285–98.
25. Aziz MH, Afaq F, Ahmad N. Prevention of ultraviolet-B radiation damage by resveratrol in mouse skin is mediated via modulation in survivin. *Photochem Photobiol* 2005;81:25–31.
26. Athar M, Back JH, Tang X et al. Resveratrol: A review of preclinical studies for human cancer prevention. *Toxicol Appl Pharmacol* 2007;224:274–83.
27. Ruby AJ, Kuttan G, Babu KD, Rajasekharan KN, Kuttan R. Anti-tumour and antioxidant activity of natural curcuminoids. *Cancer Lett* 1995;94:79–83.
28. Surh YJ, Han SS, Keum YS, Seo HJ, Lee SS. Inhibitory effects of curcumin and capsaicin on phorbol ester-induced activation of eukaryotic transcription factors, NF-kappaB and AP-1. *Biofactors* 2000;12:107–12.
29. Phillips J, Moore-Medlin T, Sonavane K et al. Curcumin inhibits UV radiation-induced skin cancer in SKH-1 mice. *Otolaryngol Head Neck Surg* 2013;148:797–803.
30. Hwang BM, Noh EM, Kim JS et al. Curcumin inhibits UVB-induced matrix metalloproteinase-1/3 expression by suppressing the MAPK-p38/JNK pathways in human dermal fibroblasts. *Exp Dermatol* 2013;22:371–4.
31. Syed DN, Malik A, Hadi N et al. Photochemopreventive effect of pomegranate fruit extract on UVA-mediated activation of cellular pathways in normal human epidermal keratinocytes. *Photochem Photobiol* 2006;82:398–405.
32. Lee TH, Do MH, Oh YL et al. Dietary fermented soybean suppresses UVB-induced skin inflammation in hairless mice via regulation of the MAPK signaling pathway. *J Agric Food Chem* 2014;62(36):8962–72.
33. Wei H, Wei L, Frenkel K, Bowen R, Barnes S. Inhibition of tumor promoter-induced hydrogen peroxide formation *in vitro* and *in vivo* by genistein. *Nutr Cancer* 1993;20:1–12.
34. Wang Y, Zhang X, Leibold M, DeLeo V, Wei H. Inhibition of ultraviolet B (UVB)-induced c-fos and c-jun expression *in vivo* by a tyrosine kinase inhibitor genistein. *Carcinogenesis* 1998;19:649–54.
35. Petrova A, Davids LM, Rautenbach F, Marnewick JL. Photoprotection by honeybush extracts, hesperidin and mangiferin against UVB-induced skin damage in SKH-1 mice. *J Photochem Photobiol B* 2011;103:126–39.
36. Sime S, Reeve VE. Protection from inflammation, immunosuppression and carcinogenesis induced by UV radiation in mice by topical Pycnogenol. *Photochem Photobiol* 2004;79:193–8.
37. Packer L, Rimbach G, Virgili F. Antioxidant activity and biologic properties of a procyanidin-rich extract from pine (*Pinus maritima*) bark, pycnogenol. *Free Radic Biol Med* 1999;27:704–24.
38. Rohdewald P. A review of the French maritime pine bark extract (Pycnogenol), a herbal medication with a diverse clinical pharmacology. *Int J Clin Pharmacol Ther* 2002;40:158–68.
39. Cho KJ, Yun CH, Yoon DY et al. Effect of bioflavonoids extracted from the bark of *Pinus maritima* on proinflammatory cytokine interleukin-1 production in lipopolysaccharide-stimulated RAW 264.7. *Toxicol Appl Pharmacol* 2000;168:64–71.
40. Huynh HT, Teel RW. Selective induction of apoptosis in human mammary cancer cells (MCF-7) by pycnogenol. *Anticancer Res* 2000;20:2417–20.
41. Scarpa M, Stevanato R, Viglino P, Rigo A. Superoxide ion as active intermediate in the autoxidation of ascorbate by molecular oxygen. Effect of superoxide dismutase. *J Biol Chem* 1983;258:6695–7.
42. Darr D, Combs S, Dunston S, Manning T, Pinnell S. Topical vitamin C protects porcine skin from ultraviolet radiation-induced damage. *Br J Dermatol* 1992;127:247–53.

43. Nakamura T, Pinnell SR, Darr D et al. Vitamin C abrogates the deleterious effects of UVB radiation on cutaneous immunity by a mechanism that does not depend on TNF-alpha. *J Invest Dermatol* 1997;109:20–4.
44. Niki E. Role of vitamin E as a lipid-soluble peroxy radical scavenger: *In vitro* and *in vivo* evidence. *Free Radic Biol Med* 2014;66:3–12.
45. Bissett DL, Majeti S, Fu JJ, McBride JF, Wyder WE. Protective effect of topically applied conjugated hexadienes against ultraviolet radiation-induced chronic skin damage in the hairless mouse. *Photodermatol Photoimmunol Photomed* 1990;7:63–7.
46. Gensler HL, Magdaleno M. Topical vitamin E inhibition of immunosuppression and tumorigenesis induced by ultraviolet irradiation. *Nutr Cancer* 1991;15:97–106.
47. Jurkiewicz BA, Bissett DL, Buettner GR. Effect of topically applied tocopherol on ultraviolet radiation-mediated free radical damage in skin. *J Invest Dermatol* 1995;104:484–8.
48. Trevithick JR, Xiong H, Lee S et al. Topical tocopherol acetate reduces post-UVB, sunburn-associated erythema, edema, and skin sensitivity in hairless mice. *Arch Biochem Biophys* 1992;296:575–82.
49. Ortiz KJ, Yiannias JA. Contact dermatitis to cosmetics, fragrances, and botanicals. *Dermatol Ther* 2004;17:264–71.
50. Wang SQ, Osterwalder U, Jung K. *Ex vivo* evaluation of radical sun protection factor in popular sunscreens with antioxidants. *J Am Acad Dermatol* 2011;65:525–30.
51. Stahl W, Sies H. Beta-carotene and other carotenoids in protection from sunlight. *Am J Clin Nutr* 2012;96:1179S–84S.
52. Krinsky NI, Landrum JT, Bone RA. Biologic mechanisms of the protective role of lutein and zeaxanthin in the eye. *Annu Rev Nutr* 2003;23:171–201.
53. Junghans A, Sies H, Stahl W. Macular pigments lutein and zeaxanthin as blue light filters studied in liposomes. *Arch Biochem Biophys* 2001;391:160–4.
54. Kulp M, Bragina O. Capillary electrophoretic study of the synergistic biological effects of alkaloids from *Chelidonium majus* L. in normal and cancer cells. *Anal Bioanal Chem* 2013;405:3391–7.
55. Katiyar SK, Korman NJ, Mukhtar H, Agarwal R. Protective effects of silymarin against photocarcinogenesis in a mouse skin model. *J Natl Cancer Inst* 1997;89:556–66.
56. Gonzalez S, Gilaberte Y, Philips N, Juarranz A. Fernblock, a nutraceutical with photoprotective properties and potential preventive agent for skin photoaging and photoinduced skin cancers. *Int J Mol Sci* 2011;12:8466–75.
57. Turkoglu M, Cigirgil N. Evaluation of black tea gel and its protection potential against UV. *Int J Cosmet Sci* 2007;29:437–42.
58. Wei H, Saladi R, Lu Y et al. Isoflavone genistein: Photoprotection and clinical implications in dermatology. *J Nutr* 2003;133:3811S–9S.
59. Katiyar SK. Grape seed proanthocyanidines and skin cancer prevention: Inhibition of oxidative stress and protection of immune system. *Mol Nutr Food Res* 2008;52(Suppl 1):S71–6.
60. Khan N, Syed DN, Pal HC, Mukhtar H, Afaq F. Pomegranate fruit extract inhibits UVB-induced inflammation and proliferation by modulating NF-kappaB and MAPK signaling pathways in mouse skin. *Photochem Photobiol* 2012;88:1126–34.
61. Suwannateep N, Wanichwecharungruang S, Haag SF et al. Encapsulated curcumin results in prolonged curcumin activity *in vitro* and radical scavenging activity *ex vivo* on skin after UVB-irradiation. *Eur J Pharm Biopharm* 2012;82:485–90.
62. Sharma RA, Gescher AJ, Steward WP. Curcumin: The story so far. *Eur J Cancer* 2005;41:1955–68.
63. Han D, Row KH. Separation and purification of sulforaphane from broccoli by solid phase extraction. *Int J Mol Sci* 2011;12:1854–61.
64. Antille C, Tran C, Sorg O et al. Vitamin A exerts a photoprotective action in skin by absorbing ultraviolet B radiation. *J Invest Dermatol* 2003;121:1163–7.
65. Damian DL, Patterson CR, Stapelberg M et al. UV radiation-induced immunosuppression is greater in men and prevented by topical nicotinamide. *J Invest Dermatol* 2008;128:447–54.
66. Deutsch JC, Kolhouse JF. A mechanism of inhibition of short-wavelength ultraviolet light-induced deamination of pyrimidine bases by ascorbic acid. *Mutat Res* 1993;302:183–90.
67. McVean M, Liebler DC. Prevention of DNA photodamage by vitamin E compounds and sunscreens: Roles of ultraviolet absorbance and cellular uptake. *Mol Carcinog* 1999;24:169–76.

Kumi Arakane and Eiji Naru

Introduction

Ultraviolet (UV) rays are invisible electromagnetic waves with a wavelength of 100–400 nm, classified as vacuum UV (100–190 nm), UVC (190–290 nm), UVB (290–320 nm), and UVA (320–400 nm) based on their biologic activity. Vacuum UV and UVC do not reach the surface of the earth, whereas approximately half of all UVB and almost all UVA rays reach the earth's surface. UV (UVB + UVA) energy comprises only a small amount of the total energy of the sun's rays. Nevertheless, UV rays cause crucial damage with quite high energy to living organisms, and various defense systems have evolved in these organisms for protection.

UV rays have considerable effects on human skin over both the short- and long-term. Chronic UV exposure to the skin causes dermal alterations¹ and photoaging.² These effects are observed not only in the dermis but also in the epidermis. Deep wrinkles and epidermal thickening are typical features of photoaging. The effects of UV depend on the wavelength.³

UVB damages DNA directly and induces pigment changes (suntan) and sunburned cells within a few days. Epidermal thickening and melanogenesis occur within a week. UVB exposure induces photoaging of the skin⁴ and also enhances skin carcinogenesis.^{5,6} Thus, UV protection is recommended beginning in childhood.^{7–9}

UVA penetrates deeper into the dermis than UVB and accelerates photoaging. Many substances have an absorbance within both UVB and UVA regions, and UV irradiation of these substances can cause reactive oxygen generation, phototoxicity, and photosensitization. Therefore, UVA-induced damage prevention is also an important issue.

It is very important to understand the mechanisms of the effects of UV exposure. In this chapter, we describe the effects of UV exposure and discuss various protective approaches.

Acute UV-Induced Skin Damage

Skin damage in response to UV irradiation is classified as acute and chronic. An acute skin reaction to excessive sunlight exposure generally includes the inflammation of “sunburn” and the subsequent pigmentation of “suntan.” Sunburn is an acute erythema response in UVB-exposed skin. Generally, an erythema reaction occurs within a few hours after UV exposure and reaches a maximum approximately 12–24 hours after exposure. DNA damage after UVB irradiation results in the erythema reaction.¹⁰ Cross-linking reactions of pyrimidine residues in DNA directly affect the cell.^{11,12} Pro-inflammatory cytokines are released from dermal keratinocytes after UVB exposure.¹³ These cytokines and chemokines have important roles in the response of UV-irradiated human skin, for example, erythema reaction (interleukin [IL]-8, tumor necrosis factor [TNF]- α),¹⁴ impaired skin immune system (IL-10),¹⁵ and apoptosis (TNF- α).¹⁰

The minimum erythema dose (MED) is widely used as an index of skin reactions to UV. The MED is the minimum dose of UVB that causes erythema reactions of the skin 24 hours after exposure. The minimum dose of UVB that will produce an erythema reaction in the skin varies. The effects of UV at each wavelength are expressed by a graph and termed the “erythemal action spectrum.”¹⁶ In sunlight,

the spectrum around 310 nm has the greatest contribution to the induction of an erythema reaction. Therefore, compounds with a cutoff around 310 nm are very effective for protecting against sunburn. Accordingly, various sunscreen agents, both UV-scattering agents and UV absorbers, are being developed. The personal MED value differs because the individual erythema dose of UV irradiation differs between people. The Commission Internationale de l'Éclairage Ina (CIE) proposes a standard erythema dose of 100 J/m².¹⁷

The sequence of acute responses includes histologic changes, such as sunburned cells and epidermal thickening resulting from the hyper-proliferation of keratinocytes,¹⁸ followed by erythema. The formation of sunburned cells, a histologic change, is an index of UVB-induced skin damage. Sunburned cells are defined as apoptotic keratinocytes within the epidermis that are observed as eosinophilic cytoplasm and a hematoxylinophilic condensed nucleus upon staining with hematoxylin and eosin.^{19,20} The formation of sunburned cells is reduced when the cell cycle is suppressed,²¹ and UV sensitivity of keratinocytes is considered to depend on the cell cycle.²²

UVB accelerates melanogenesis in the skin.²³ α -Melanocyte-stimulating hormone, endothelin-1, stem cell factor, granulocyte-macrophage colony-stimulating factor, and prostaglandin all induce melanogenesis, and are released from UVB-irradiated keratinocytes and dermal fibroblasts.^{24,25}

UVB accelerates epidermal thickening within a few days by temporal keratinocyte hyper-proliferation in which defective stratum corneum lipid layers are observed. Abrupt stratum corneum thickening results in an increase of transepidermal water loss (TEWL) by the inadequate stratum corneum lipid layer. Damaged stratum corneum is replaced within a few weeks along with a decrease in TEWL.

UVB irradiation affects the dermal immune system²⁶ and decreases Langerhans cells in the skin.²⁷⁻²⁹ IL-10, IL-12, and TNF- α contribute to these phenomena.^{30,31} On the other hand, narrowband UVB irradiation is applied for the treatment of psoriasis patients to reduce excess immune reactivity.³²

Chronic UV-Induced Skin Damage

UV damages not only dermal essential elements, such as collagen and elastin, which maintain the elasticity and firmness of the skin, but also the function of the fibroblasts producing these elements. People engaged in frequent outdoor activities or who are exposed to sunlight over long periods of time often have atrophic, shriveled, and pigmented skin. The features are prominently observed only in sun-exposed areas, and are apparently due to chronic damage from accumulated UV exposure. These changes are due to frequent sun exposure in daily life over an extended period.³³ The chronic damage of manifestations on the skin is referred to as photoaging and is distinguished from normal intrinsic aging.

Changes in appearance include large deep wrinkles; histologic changes, including thickening of the epidermis and dermis; elastin fiber deposition; and decreased collagen fibers, and are observed as a result of continuous UV (UVB or UVB + UVA) irradiation.³ Varani et al. reported that fibroblasts from photoaged skin exhibit decreased collagen production compared to fibroblasts from unexposed areas.³⁴ In photoaged skin, fibroblast deterioration, collagen degradation, and banding of the collagen fibers also occur.^{35,36} These changes affect the homeostasis of the extracellular matrix. UV irradiation induces many types of matrix metalloproteinases (MMPs).^{37,38} Photoaging has complicated causes that depend on the wavelength. UVB induces the insolubilization of collagen fibers, and UVA decreases the diameters of collagen fibrils.³

The effects of UVA, which penetrates deep into the skin, are attributed to the generation of active oxygen from photosensitizers. Thus, UVA is closely involved in dermal denaturation and photoaging. Reactive oxygen species (ROS) generated in the skin are thought to damage tissue and cells. Cellular aging is accelerated in a donor age-dependent manner based on studies of fibroblasts from the same donor.³⁹ The sensitivity of dermal fibroblasts to UVA also increases with donor age (Table 22.1).⁴⁰ These findings indicate that the effects of UV are exacerbated by aging.

An increase in the tissue iron content in photoaged skin is associated with a chronic increased permeability of the skin vasculature in sun-exposed skin. Ferric ion-mediated reactivity of ROS is suggested to be involved in photoaging.⁴¹ Ferric ions are controlled by the binding proteins ferritin and transferrin.

TABLE 22.1

Relationship between Donor Age and Cell Life Span Shortening Induced by Repeated UVA Irradiation

Cell	Donor Age	Cell Life Span (Mean ± SEM)		Life Span Shortening (%)
		Non-Irradiated	UVA Irradiated	
ASF-4-1	36.2	62.85 ± 1.08	60.79 ± 2.03	-3.28
ASF-4-2	47.5	55.84 ± 0.40	52.56 ± 0.13	-5.87
ASF-4-3	56.9	54.37 ± 2.52	50.39 ± 2.55	-7.31
ASF-4-4	62.6	42.34 ± 1.50	34.72 ± 0.07	-18.01

Note: Two-way analysis of variance was performed and the interaction between treatments was significant ($P < 0.0001$).

Elastin is an insoluble extracellular matrix protein and the core protein of elastic fibers that impart elasticity to skin. Histologically, an accumulation of disintegrated amorphous elastic fibers is observed in the solar elastosis region.^{42,43} Elastin is secreted as tropoelastin in the extracellular matrix. The biologic process of elastic fibers is complicated. It has multiple components and is assembled via several steps and stringently regulated developmental processes.⁴⁴

Fibrillin-1 is a large extracellular matrix glycoprotein that promotes elastogenic processes through tropoelastin deposition after coacervation. The expression of fibrillin-1, which acts as a scaffold protein for tropoelastin deposition, is suppressed by UVA irradiation.⁴⁵ It is suggested that incompletely assembled elastic fibers lose their essential function due to decreased fibrillin-1 and aggregated excess elastin in chronically sun-exposed skin.

Advanced glycation endproducts (AGEs), endproducts of the Maillard reaction, are found in areas of actinic elastosis, suggesting their involvement in photoaging.^{46,47} Because AGEs produce ROS when exposed to UVA irradiation, ROS may also be involved in AGE production and the acceleration of elastic fiber degeneration.⁴⁸ Moreover, glycation of dermal proteins also affects skin color.^{49,50}

UVB damages Langerhans cells in the epidermis as well as keratinocytes and fibroblasts, losing the dendrites of Langerhans cells and decreasing the Langerhans cell density. The morphologic damage induced by UVB requires at least a few weeks to repair.⁵¹ Repeated UVB irradiation of a sub-erythema dose causes more damage than a single dose of irradiation at the same dose (Figure 22.1).²⁹ A decrease in the Langerhans cells in chronically UV-exposed skin has also been reported.^{52,53} Damage to the epidermis caused by UV-induced immune suppression leads to decreased dermal immune function.

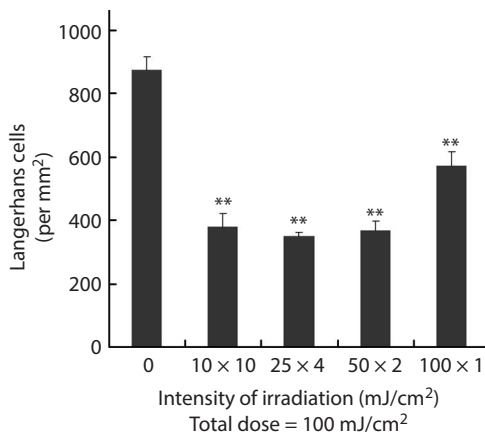

FIGURE 22.1 Number of Langerhans cells in repeated UVB-irradiated epidermal specimens. The total energy of each irradiation was 100 mJ/cm². The number of Langerhans cells decreased (25 mJ/cm²) in specimens irradiated four times compared with specimens irradiated only one time (100 mJ/cm²). Data are presented as means ± SD (n = 12). ** $P < 0.01$, vs. no irradiation, Dunnett’s test.

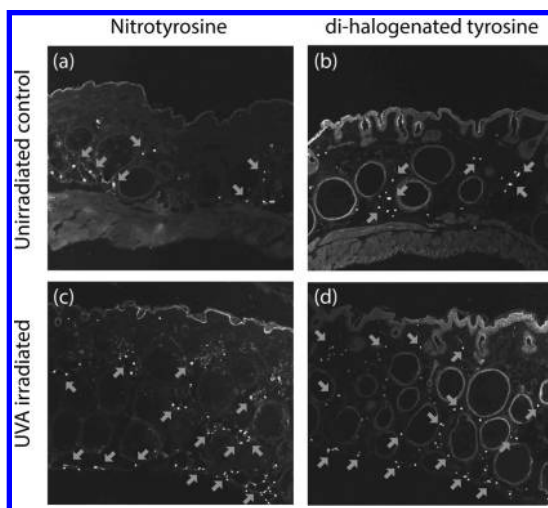

FIGURE 22.2 Immunohistochemical staining of modified tyrosine residue in mouse back skin. (a, b) are unirradiated control. (c, d) are UVA irradiated skin at a dose of 10 J/cm² five times per week for 15 weeks. Arrows indicate modified tyrosine-positive sites. Bar indicates 200 μ m.

Inflammatory mononuclear cell infiltration is observed in photoaged skin. These inflammatory cells generate various ROS and peroxides, such as superoxide, peroxynitrite, and hypochlorous acid, to protect against exogenous factors. ROS also damage the tissue. Nitrated and halogenated tyrosine-positive sites are increased in long-term UVA-irradiated mouse skin. The increase in these modified proteins is closely related to the peroxidases released from inflammatory cells (Figure 22.2).⁵⁴

ROS Generated by UV Irradiation and Skin Damage

Skin is exposed to the air and is a unique organ in terms of oxygen-induced stress. Although the skin protects other organs from oxygen and UV damage, it is an important source of ROS generated by UV irradiation. ROS are responsible for many diseases. ROS generated by UV induce not only skin damage such as sunburn, phototoxicity, and photoallergy, but also skin diseases such as atopic dermatitis and psoriasis.^{55,56} As ROS are highly reactive, various neighboring *in vivo* substances are affected and cause oxidative damage, such as lipid peroxidation, protein modification, and DNA damage. Accumulation of oxidative damage leads to aging effects. ROS disrupt the regulatory mechanisms of common inflammatory genes. Activator protein-1 (AP-1) and nuclear factor- κ B (NF- κ B) are key transcription factors in the oxidative stress reaction. Suppression of inflammatory reactions is a promising approach for UV-caused damage as well as ROS scavenging.

Reactive Oxygen Species

ROS generated by UV irradiation include singlet oxygen (¹O₂), superoxide anions (O₂⁻), hydrogen peroxide (H₂O₂), and hydroxyl radicals (\cdot OH). H₂O₂ is catalyzed by ferric ions. This reaction is called the “Fenton reaction” and it generates highly reactive hydroxyl radicals that damage surrounding cells and tissues. Catalase is a very important enzyme that catalyzes hydrogen peroxide to water and oxygen. UVA irradiation specifically decreases catalase activity among antioxidant enzymes in the skin.^{57,58} Moreover, the catalase content decreases in an age-dependent manner.⁵⁹ Fibroblasts treated with 3-amino-1H-1,2,4-triazole, a specific catalase inhibitor, have increased H₂O₂ concentrations and cellular damage is aggravated, similar to that after UVB irradiation.⁶⁰ Hydrogen peroxide generated in cells injures the mitochondria.⁶¹ Mitochondrial impairment by UV irradiation is ascribed to ROS generation from the

respiration chain.⁶² Hydroxyl radicals can be detected using electron spin resonance spectral measurement in UVB-irradiated dermal fibroblasts. After UVB irradiation, accumulated H_2O_2 in cells is thought to be converted to hydroxyl radicals in the presence of metal ions.⁶³

Singlet Oxygen

Photosensitivity caused by UV exposure is a major feature of photodermatosis patients. Because oral administration of the singlet oxygen ($^1\text{O}_2$) quencher β -carotene markedly relieves symptoms of photosensitivity, it is speculated that $^1\text{O}_2$ generated during the photosensitization process is a causative agent of photosensitivity.⁶⁴ Tetracyclines are representative drugs that induce phototoxicity as an adverse reaction. Members of the tetracycline family generate $^1\text{O}_2$ during UV irradiation, and the amount of $^1\text{O}_2$ generated and degree of phototoxicity are well correlated,⁶⁵ demonstrating that $^1\text{O}_2$ is a major reactive intermediate that induces tetracycline phototoxicity.

Direct measurement of the near-infrared emission spectrum corresponding to $^1\text{O}_2$ (1268 nm)⁶⁶ indicates that a metabolite of *Propionibacterium acnes*, coproporphyrin, existing on the skin surface, generates $^1\text{O}_2$ when the skin is irradiated with UV rays (Figure 22.3).⁶⁷ Porphyrins produced by *P. acnes* commonly exist on the skin and generate $^1\text{O}_2$ on UV-irradiated skin. This means that $^1\text{O}_2$ potentially induces reactions in the skin to cause various types of skin damage, not only in special cases such as the photosensitivity in erythropoietic protoporphyria, but also in healthy skin under physiologic conditions.

Recently, $^1\text{O}_2$ is detected directly in the UV-irradiated skin, and $^1\text{O}_2$ generation is also detected in UVA-irradiated fibroblasts.⁶⁸ These findings indicate that $^1\text{O}_2$ is generated via a photosensitization reaction in UV-irradiated skin. Other $^1\text{O}_2$ generation pathways are mediated by peroxidases derived from inflammatory cells.

Lipid Peroxide

ROS oxidize various neighboring substances and generate peroxides in living cells and organs. There are many kinds of lipids in the skin, such as free fatty acids, triglycerides, squalene, cholesterol, and ceramides. Lipid oxidation reactions progress automatically due to lipid radicals generated by ROS. $^1\text{O}_2$ is responsible for UV-induced peroxidation of skin surface lipids (Figure 22.4).⁶⁹ $^1\text{O}_2$ also induces cross-linking of collagen fibers, which is the major component of dermis (Figure 22.5).⁷⁰ Further, $^1\text{O}_2$ is the focus of studies examining the ROS responsible for cellular aging in chronic UVA-irradiated cultured human dermal fibroblasts.⁷¹

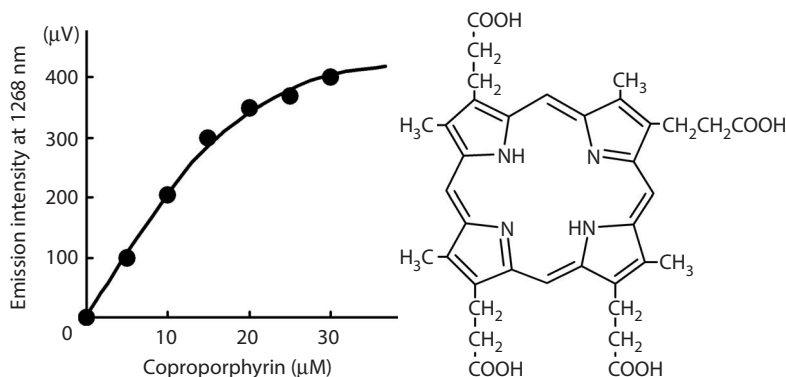

FIGURE 22.3 Singlet oxygen emission photosensitized by coproporphyrin. Singlet oxygen generation in coproporphyrin solution (5–30 mM) excited by Argon laser light in the UVA region with 100 mW output power was monitored by measuring the emission intensity at 1268 nm. (From Arakane K et al. *Biochem Biophys Res Commun* 1996;223:578–82. With permission.)

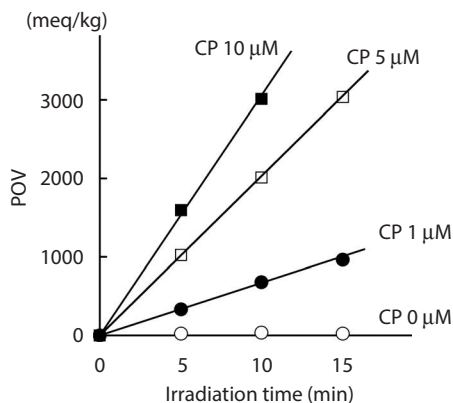

FIGURE 22.4 Peroxidation of skin surface lipids (squalene) by singlet oxygen produced by coproporphyrin. Squalene (5 mmol/L) chloroform/methanol solution was irradiated with UVA using a solar simulator with coproporphyrin (0–10 mmol/L) and POV was measured at the indicated time. POV: peroxide value.

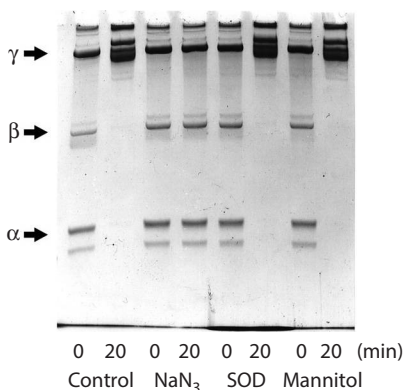

FIGURE 22.5 Effect of various quenchers on collagen cross-linking induced by ROS. Collagen solutions in 50 mM Tris-HCl buffer (pH 7.5) with various quenchers of ROS (100 mmol/L NaN₃, 10 mg/mL superoxide dismutase, or 10 mg/mL mannitol) were irradiated with UVA for 10 minutes with 20 mmol/L hematoporphyrin. (From Ryu A et al. *Chem Pharm Bull* 1997;45:1243–1247. With permission.)

Squalene peroxide, which is easily generated by singlet oxygen, induces skin hyper-pigmentation through increasing the release of prostaglandin E₂ from keratinocytes.⁷² Based on these reports, ¹O₂ is closely linked to dermal disorders caused by excess UV exposure.

Prevention of Skin Damage

Antioxidants

Various antioxidants prevent sunburn cell formation, which is used as an index of UV-induced epidermal damage. Major antioxidants, vitamin C,⁷³ superoxide dismutase,^{74,75} and tocopherol (vitamin E)⁷⁶ indeed suppress UV-induced damage. One study reported that a superoxide dismutase-containing cream was effective toward preventing an increase in lipid peroxide.⁷⁷

Application of combined antioxidants works effectively.⁷⁸ Many studies have focused on major antioxidant vitamins; vitamin C and vitamin E,^{76,79,80} other vitamins; niacin amide,⁸¹ folic acid,^{82,83} and specific antioxidants; lutein,⁸⁴ CoQ₁₀,⁸⁵ and flavonoids.^{86–88}

The transcription factor NF-κB, which plays an important role in the expression of genes involved in inflammatory and immune responses, is activated by UVB irradiation.^{89,90} NF-κB is also a critical transcription factor of extracellular degrading enzymes.⁹¹ Cysteine derivatives and DL-α-lipoic acid suppress the activation of NF-κB.⁹² Collagenase and stromelysin are members of the MMP family, which are structurally related proteins that degrade extracellular matrix proteins. MMP-9 is induced by UVB in keratinocytes⁹³ and is thought to degrade the basement membrane. AP-1 is also an important transcription factor of MMPs that is suppressed by ¹O₂ quenchers.⁹⁴ ¹O₂ quenching is effective against the shortened cell life span that results from chronic UVA irradiation of human dermal fibroblasts.⁷¹

Carotenoids

Carotenoids are a kind of terpenoid synthesized in plants. Carotenoids are categorized as carotenes, which are pro-vitamin A, and xanthophylls, such as astaxanthin, lutein, etc. Pro-vitamin A is converted to vitamin A (retinol) in the body as necessary. Retinol, retinal, and retinoic acid are referred to as retinoids and are used in cosmetics. Retinoic acids are effective against photoaging.² Tretinoin, all-trans retinoic acid, is quite effective against wrinkle formation.⁹⁵ Retinoids are also used to treat acne care. Retinoids are difficult to include in cosmetic formulations, however, because of their instability.

Carotenoids have high antioxidative activity. Oral administration of phytofluene and phytoene suppress erythema reactions induced by UV irradiation.⁹⁶ β-Carotene and lycopene also have similar effects.⁹⁷

Astaxanthin is the most effective ¹O₂ quencher among the carotenoids (Figure 22.6). Astaxanthin significantly reduces wrinkles in hairless mice as a model of photoaging (Figure 22.7).⁹⁸ The ¹O₂-quenching ability of astaxanthin is extremely high compared to vitamin E or β-carotene. Electron micrographs of the ultrastructure of dermal collagen and elastin fiber bundles show that the application of astaxanthin maintains the bundle structures of dermal collagen and elastin fibers that are destroyed by UVB irradiation over a long period of time.

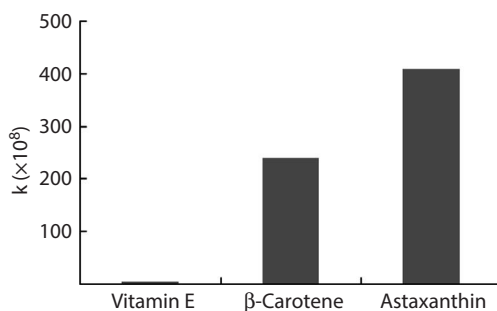

FIGURE 22.6 Rate constant of reaction of astaxanthin, β-carotene, and vitamin E with singlet oxygen.

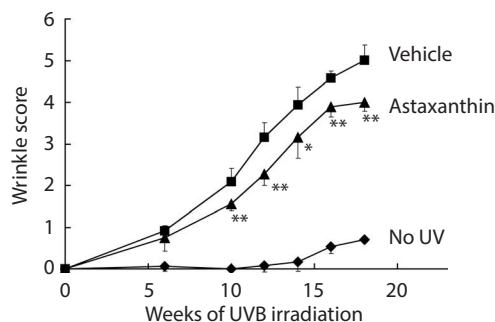

FIGURE 22.7 Inhibitory effect of astaxanthin on UVB-induced skin aging. Grading score for visible changes in mouse skin induced by vehicle (▲), astaxanthin (■), and no UVB (◆). Data are expressed as means ± SD (n = 6). Asterisks indicate a significant difference (*:P < 0.05, **:P < 0.01) from vehicle plus UV.

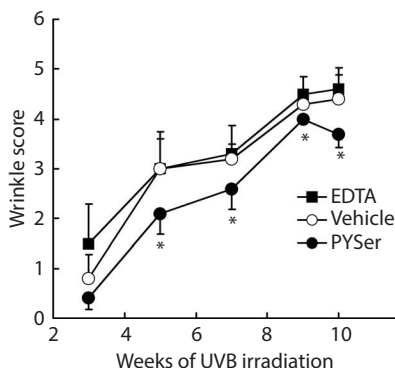

FIGURE 22.8 Inhibitory effect of PYSer on UVB-induced skin aging. Grading score for visible changes in mouse skin induced by vehicle (○), PYSer (●), and EDTA (■). Data are expressed as means \pm SD ($n = 5$). Asterisks (*) indicate a significant difference ($P < 0.05$) from vehicle plus UVB. (From Kitazawa M et al. *J Soc Cosmet Chem Jpn* 2001;35:149–154. With permission.)

Ion-Chelators

Bissett et al. reported that ion chelators prevent UV-induced photoaging.^{41,99} Chelators inhibit Fenton reactions by chelating free ferric ion and other metal ions in UV-irradiated dermis.¹⁰⁰ N-(4-Pyridoxylmethylene)-L-serine (PYSer) comprises a stabilized conjugate molecule of pyridoxal (vitamin B6) and L-serine (amino acid). PYSer is created from compounds present in the living body so it mimics the coordinated bonding and stabilization of the chelated structure of iron-sequestering proteins found in the living body and effectively suppresses the production of hydroxyl radicals. PYSer decreases the iron-catalyzed production of hydroxyl radicals. On the other hand, EDTA increases the production of hydroxyl radicals, although it is a potent iron chelator. PYSer, which decreases the iron-catalyzed production of hydroxyl radicals, significantly suppresses wrinkle formation in hairless mice (Figure 22.8).¹⁰¹

Other Anti-Wrinkle Agents

Epidermal hyperplasia is a distinct property of photoaged skin. Epidermal keratinocytes generate various cytokines upon exposure to UV irradiation. Several studies have focused on the prevention of photoaging, leading to the discovery of several ingredients. Ergocalciferol is a type of vitamin D that effectively prevents epidermal hyperplasia in chronic UVA-irradiated hairless mouse skin.¹⁰²

Polyphenols, which have multiple hydroxyl groups, are widely obtained from plants. Many useful polyphenols have been discovered. Resveratrol, present in grape skin and Japanese knotweed, is a famous Sirtuin activator. Resveratrol has anti-inflammatory and antioxidant effects on UV irradiated skin.^{103,104} Resveratrol prevents leucocyte infiltration into dermis and metabolic disease.¹⁰⁵ Ergothioneine,¹⁰⁶ equolgenistein,¹⁰⁷ and ectoin¹⁰⁸ also effectively protect against UV irradiation and photoaging.

Dietary effects of antioxidants will continue to be investigated. Carotenoids are described above, and dietary application of resveratrol and procyanidin mixtures has also been shown to reduce skin wrinkling and improve oxidative stress.¹⁰⁹

Sunscreen

UV Filters

The use of sunscreen products is one of the most important approaches to UV protection. UV filters are key ingredients in sunscreen products. Many UV filters have been developed under intense investigations. UV filters are used under the regulations of each country. Table 22.2 shows the limit of major UV

TABLE 22.2

Major UV Filters and Scattering Agents

INCI Name (Other Name)	OTC Drug Name	EU	FDA	Japan	Wavelength
Benzophenone-4	Sulisobenzone	5% (as acid)	10%	10%	B
Cinoxate (Isopentyl-4-methoxycinnamate)	Cinoxate	10%	3%	5%	B
Ethylhexyl dimethyl PABA	Padimate O	8%	8%	10%	B
Ethylhexyl methoxycinnamate (Octyl methoxycinnamate)	Octinoxate	10%	7.5%	20%	B
Ethylhexyl triazone	–	10%	–	5%	B
Ethylhexyl salicylate (Octyl-salicylate)	Octisalate	5%	5%	10%	B
Homosalate	Homosalate	10%	15%	10%	B
Phenylbenzimidazole sulfonic acid	Ensulizole	8% (as acid)	4%	3%	B
Polysilicone-15	–	10%	–	10%	B
Butyl methoxydibenzoylmethane	Avobenzone	5%	3%	10%	A
Diethylamino hydroxybenzoyl hexyl benzoate	–	10%	–	10%	A
Disodium phenyl dibenzimidazole tetrasulfonate	–	10% (as acid)	–	–	A
Octocrylene	Octocrylene	10% (as acid)	10%	10%	A
Methyl anthranilate	Methyl anthranilate	–	5%	–	A
Terephthalylidene dicamphor sulfonic acid	Ecamsule	10%	^a	10%	A
Benzophenone-3	Oxybenzone	10%	6%	5%	A + B
Bis-ethylhexyloxyphenol methoxyphenyl triazine	–	10%	–	3%	A + B
Drometrizole trisiloxane	–	15%	–	15%	A + B
Methylene bis-benzotriazolyl tetramethylbutylephenol	–	10%	–	10%	A + B
Titanium dioxide	Titanium dioxide	25%	25%	<100%	
Zinc oxide	Zinc oxide	–	25%	<100%	

^a Unpublished.

filters and scattering agents in the product in the European Union (EU), United States, and Japan.^{110–112} UV filters continue to be improved with regard to their function, usage, stability, water solubility, and retention on the skin.

Sun Protection Factor

The sun protection factor (SPF) is an index of the effectiveness of sunscreen products, and it is used widely throughout the world. SPF is calculated from the ratio at the dose of erythema reaction by UVB irradiation with or without sunscreen on the skin. The ISO24444¹¹³ has been adopted internationally as a standard SPF measuring method. The U.S. Food and Drug Administration (FDA) has adopted a similar method, but regulations for SPF claims on sunscreen products differ widely between countries. Regulations regarding SPF indication may follow a stepwise indication method, indication within a fixed rate, or indication with an integral number rounded down after the decimal point. Maximum SPF indication is generally limited in many countries. SPF50+ is used widely as the maximum SPF value of the sunscreen products.

UVA Protection

UVA protection is currently aimed at preventing the acceleration of photoaging. The UVA protection factor (UVAPF) was developed against persistent pigment darkening at the UVA-irradiated area. ISO24442¹¹⁴ has been adopted as a measure of UVAPF. ISO24443¹¹⁵ was also developed as a method of measuring *in vitro* UVA protection. Moreover, critical wavelength indicates the balance of the protection efficiency in the UV-irradiated region. Critical wavelength is calculated from wavelengths below 90% of the area under the absorbance curve from 290 nm to 400 nm.

Claims for UVA protection by various products differ between countries. In Japan, four grades of PA (protection grade of UVA) are indicated, which is based on the UVAPF value. The EU requires indicating a “Broad spectrum” or “UVA protection” claim on sunscreen products, if the UVAPF is at least 1/3 of the labeled SPF and its minimum critical wavelength is 370 nm.¹¹⁶ In the United States, the FDA requires that the term “Broad Spectrum” be used only on products with a minimum critical wavelength of 370 nm and an SPF of 15 or higher.¹¹⁷ Moreover, the product information must state that using sunscreen may reduce the risk of skin cancer and skin aging. Other countries have regulations similar to those of Japan or EU. Common regulation practices, however, are not yet established. As explained above, regulations regarding UVA protection of the sunscreen differ throughout the world.

Application of Sunscreen

To determine the SPF, 2 mg/cm² sunscreen is applied to the skin.¹¹⁸ The relation between the actual application thickness and SPF value of the product, however, is a matter of debate.^{119–121} We measured the application thickness of sunscreen on the face and arms. Although the mean application thickness was approximately 1 mg/cm², double application reached 2 mg/cm² and exerted the expected SPF value. The relationship between application volume and SPF value is not a linear correlation, and even application of a small amount provides good protection (Table 22.3).¹²²

TABLE 22.3

SPF Values of Various Application Amounts

Total Amount (mg/cm ²)	Application (mg/cm ²)	Times	SPF (Mean ± s.d.)
2	2	1	53.8 ± 5.5
1	1	1	44.7 ± 3.4
0.5	0.5	1	33.6 ± 3.8
2	1	2	56.8 ± 5.5
1	0.5	2	46.6 ± 8.4

Prevention of Photoactivation

Photoactivation causes phototoxicity and photosensitization. Prevention of photoactivation is an effective measure against diseases that are photoactivated within a defined action spectrum, such as porphyrias and solar urticaria.

Porphyrias are a group of genetic disorders of the heme metabolic pathway. In erythropoietic protoporphyria, protoporphyrin IX accumulates in the body.¹²³ The accumulation of protoporphyrin in the skin causes an acute painful burning sensation after sun exposure by a photoactivation reaction of protoporphyrin IX, which absorbs UV to visible light with a maximum absorbance wavelength of 410 nm. Tatebayashi et al. designed a product that blocks UVA-visible light region, and it has demonstrated efficacy in patient.¹²⁴ Further studies of various substances and action spectra responsible for other lesions will lead to the development of suitable photo-prevention products.

Conclusion

Acute and chronic skin damage caused by UV irradiation places a significant burden on the maintenance of skin homeostasis and defense systems. Dermal histologic and biochemical effects lead to changes in the appearance of the skin, such as increased pigmentation and wrinkle formation. Protecting the skin not only from intense UV exposure in the high mountains or on the beach but also from daily UV exposure is important toward maintaining our defense systems that are responsible for healthy, beautiful, and youthful skin.

UV protection is aimed at preventing UV irradiation and ROS generation. UV protection is one of the most important functions of cosmeceutical products. To improve the efficacy of cosmetics and provide more precise results, further dermatologic studies are in progress to develop more effective materials, advanced cosmetics, and effective usage. UV protection is becoming increasingly important for health and life.

REFERENCES

1. Johnston KJ, Oikarinen AI, Lowe NJ, Clark JG, Uitto J. Ultraviolet radiation-induced connective tissue changes in the skin of hairless mice. *J Invest Dermatol* 1984;82:587–90.
2. Kligman LH. Photoaging. Manifestations, prevention, and treatment. *Dermatol Clin* 1986;4:517–28.
3. Zheng P, Kligman LH. UVA-induced ultrastructural changes in hairless mouse skin: A comparison to UVB-induced damage. *J Invest Dermatol* 1993;100:194–9.
4. Chatterjee R, Benzinger MJ, Ritter JL, Bissett DL. Chronic ultraviolet B radiation-induced biochemical changes in the skin of hairless mice. *Photochem Photobiol* 1990;51:91–7.
5. Berg RJ, van Kranen HJ, Rebel HG et al. Early p53 alterations in mouse skin carcinogenesis by UVB radiation: Immunohistochemical detection of mutant p53 protein in clusters of preneoplastic epidermal cells. *Proc Natl Acad Sci USA* 1996;93:274–8.
6. Sauter ER, Klein-Szanto AJ, Atillasoy E et al. Ultraviolet B-induced squamous epithelial and melanocytic cell changes in a xenograft model of cancer development in human skin. *Mol Carcinog* 1998;23:168–74.
7. Dixon H, Borland R, Hill D. Sun protection and sunburn in primary school children: The influence of age, gender, and coloring. *Prev Med* 1999;28:119–30.
8. Stanton WR, Janda M, Baade PD, Anderson P. Primary prevention of skin cancer: A review of sun protection in Australia and internationally. *Health Promot Int* 2004;19:369–78.
9. Cancer Council Australia. *Sun Smart schools and early childhood programs*. Sydney: Cancer Council Australia; 2014.
10. Svobodová AR, Galandáková A, Sianská J et al. DNA damage after acute exposure of mice skin to physiological doses of UVB and UVA light. *Arch Dermatol Res* 2012;304:407–12.
11. Ravanat JL, Douki T, Cadet J. Direct and indirect effects of UV radiation on DNA and its components. *J Photochem Photobiol B* 2001;63:88–102.
12. Cadet J, Mouret S, Ravanat JL, Douki T. Photoinduced damage to cellular DNA: Direct and photosensitized reactions. *Photochem Photobiol* 2012;88:1048–65.

13. Yoshizumi M, Nakamura T, Kato M et al. Release of cytokines/chemokines and cell death in UVB-irradiated human keratinocytes, HaCaT. *Cell Biol Int* 2008;32:1405–11.
14. Bashir MM, Sharma MR, Werth VP. TNF-alpha production in the skin. *Arch Dermatol Res* 2009;301:87–91.
15. Rivas JM, Ullrich SE. Systemic suppression of delayed-type hypersensitivity by supernatants from UV-irradiated keratinocytes. An essential role for keratinocyte-derived IL-10. *J Immunol* 1992;149:3865–71.
16. McKinley AF, Diffey BL. A reference action spectrum for ultraviolet induced erythema in human skin. *CIE J* 1987;6:17–22.
17. ISO. *Erythema Reference Action Spectrum and Standard Erythema Dose*. ISO 17166:1999(E)/CIE S 007/E-1998. Geneva:ISO.
18. Sterenborg HJ, de Grujil FR, van der Leun JC. UV-induced epidermal hyperplasia in hairless mice. *Photodermatology* 1986;3:206–14.
19. Daniels F, Brophy D, Lobitz W. Histochemical responses of human skin following ultraviolet irradiation. *J Invest Dermatol* 1961;37:351–7.
20. Olson RL, Gaylor J, Everett MA. Ultraviolet-induced individual cell keratinization. *J Cutan Pathol* 1974;1:120–5.
21. Danno K, Takigawa M, Horio T. Relationship of the cell cycle to sunburn cell formation. *Photochem Photobiol* 1981;34:203–6.
22. Danno K, Horio T. Formation of UV-induced apoptosis relates to the cell cycle. *Br J Dermatol* 1982;107:423–8.
23. Costin GE, Hearing VJ. Human skin pigmentation: Melanocytes modulate skin color in response to stress. *FASEB J* 2007;21:976–94.
24. Hirobe T. Role of keratinocyte-derived factors involved in regulating the proliferation and differentiation of mammalian epidermal melanocytes. *Pigment Cell Res* 2005;18:2–12.
25. Yamaguchi Y, Hearing VJ. Physiological factors that regulate skin pigmentation. *Biofactors* 2009;35:193–9.
26. Roberts LK, Schmitt M, Daynes RA. Tumor-susceptibility generated in mice treated with subcarcinogenic doses of 8-methoxypsoralen and long-wave ultraviolet light. *J Invest Dermatol* 1979;72:306–9.
27. Alcalay J, Goldberg LH, Wolf JE Jr, Kripke ML. Ultraviolet radiation-induced damage to human Langerhans cells *in vivo* is not reversed by ultraviolet A or visible light. *J Invest Dermatol* 1990;95:144–6.
28. Takashima A. UVB-dependent modulation of epidermal cytokine network: Roles in UVB-induced depletion of Langerhans cells and dendritic epidermal T cells. *J Dermatol* 1995;22:876–87.
29. Ishitsuka Y, Masunaga T, Koide C, Arakane K. Repeated irradiation with suberythemal ultraviolet B reduces the number of epidermal Langerhans cells. *Arch Dermatol Res* 2003;295:155–9.
30. Granstein RD, Matsui MS. UV radiation-induced immunosuppression and skin cancer. *Cutis* 2004;74:4–9.
31. Ullrich SE, Byrne SN. The immunologic revolution: Photoimmunology. *J Invest Dermatol* 2012;132:896–905.
32. Lapolla W, Yentzer BA, Bagel J, Halvorson CR, Feldman SR. A review of phototherapy protocols for psoriasis treatment. *J Am Acad Dermatol* 2011;64:936–49.
33. Mac-Mary S, Sainthillier JM, Jeudy A et al. Assessment of cumulative exposure to UVA through the study of asymmetrical facial skin aging. *Clin Interv Aging* 2010;5:277–84.
34. Varani J, Spearman D, Perone P et al. Inhibition of type I procollagen synthesis by damaged collagen in photoaged skin and by collagenase-degraded collagen *in vitro*. *Am J Pathol* 2001;158:931–42.
35. Varani J, Schuger L, Dame MK et al. Reduced fibroblast interaction with intact collagen as a mechanism for depressed collagen synthesis in photodamaged skin. *J Invest Dermatol* 2004;122:1471–9.
36. Varani J, Dame MK, Rittie L et al. Decreased collagen production in chronologically aged skin: Roles of age-dependent alteration in fibroblast function and defective mechanical stimulation. *Am J Pathol* 2006;168:1861–8.
37. Wlaschek M, Bolsen K, Herrmann G et al. UVA-induced autocrine stimulation of fibroblast-derived-collagenase by IL-6: A possible mechanism in dermal photodamage? *J Invest Dermatol* 1993;101:164–8.
38. Koivukangas V, Kallioinen M, Autio-Harminen H, Oikarinen A. UV irradiation induces the expression of gelatinases in human skin *in vivo*. *Acta Derm Venereol* 1994;74:279–82.

39. Kaji K, Ohta T, Horie N, Naru E, Hasegawa M, Kanda N. Donor age reflects the replicative lifespan of human fibroblasts in culture. *Hum Cell* 2009;22:38–42.
40. Naru E, Ohta T, Inomata K, Hayashi A, Kaji K. Donor age-dependent acceleration of cellular aging by repeated ultraviolet A irradiation of human dermal fibroblasts derived from a single donor. *Hum Cell* 2009;22:31–7.
41. Bissett DL, Chatterjee R, Hannon DP. Chronic ultraviolet radiation-induced increase in skin iron and the photoprotective effect of topically applied iron chelators. *Photochem Photobiol* 1991;54:215–23.
42. Fisher GJ, Wang ZQ, Datta SC, Varani J, Kang S, Voorhees JJ. Pathophysiology of premature skin aging induced by ultraviolet light. *N Engl J Med* 1997;337:1419–28.
43. Ohnishi Y, Tajima S, Akiyama M, Ishibashi A, Kobayashi R, Horii I. Expression of elastin-related proteins and matrix metalloproteinases in actinic elastosis of sun-damaged skin. *Arch Dermatol Res* 2000;292:27–31.
44. Kielty CM, Sherratt MJ, Shuttleworth CA. Elastic fibres. *J Cell Sci* 2002;115:2817–28.
45. Onoue S, Wachi H, Sato F et al. UVA irradiation-induced accumulation of fibrillin-1 fibers in cultured human skin fibroblast cells. *J Jpn Cosmet Sci Soc* 2009;33:1–6.
46. Mizutani K, Ono T, Ikeda K, Kayashima K, Horiuchi S. Photo-enhanced modification of human skin elastin in actinic elastosis by N-(carboxymethyl)lysine, one of the glycoxidation products of the Maillard reaction. *J Invest Dermatol* 1997;108:797–802.
47. Sander CS, Chang H, Salzman S et al. Photoaging is associated with protein oxidation in human skin *in vivo*. *J Invest Dermatol* 2002;118:618–25.
48. Masaki H, Okano Y, Sakurai H. Generation of active oxygen species from advanced glycation end products (AGEs) during ultraviolet light A (UVA) irradiation and a possible mechanism for cell damaging. *Biochem Biophys Acta* 1999;1428:45–56.
49. Ohshima H, Oyobikawa M, Tada A et al. Melanin and facial skin fluorescence as markers of yellowish discoloration with aging. *Skin Res Technol* 2009;15:496–502.
50. Ogura Y, Kuwahara T, Akiyama M et al. Dermal carbonyl modification is related to the yellowish color change of photo-aged Japanese facial skin. *J Dermatol Sci* 2011;64:45–52.
51. Hatao M, Mark R, Stoudemayer T, Gabriel K. Recovery process of Langerhans cells in human skin following ultraviolet B irradiation. *J Toxicol Cut Ocular Toxicol* 1993;12:293–301.
52. Thiers BH, Maize JC, Spicer SS, Cantor AB. The effect of aging and chronic sun exposure on human Langerhans cell populations. *J Invest Dermatol* 1984;82:223–6.
53. Hatao M, Stoudemayer T, Lichtin JL, Sakr A, Kligman AM. Effect of chronic actinic exposure on epidermal Langerhans cells of different ethnic groups. *J Soc Cosmet Chem* 1996;47:117–28.
54. Ishitsuka Y, Maniwa F, Koide C et al. Detection of modified tyrosines as an inflammation marker in a photo-aged skin model. *Photochem Photobiol* 2007;83:698–705.
55. Matsuo I, Ohkido M. Effect of skin surface lipid peroxidation on photosensitivity. *J Jpn Cosmet Sci Soc* 1986;10:138–40.
56. Hayashi O, Imamura S, Miyachi Y. *The Biological Role of Reactive Oxygen Species in Skin*. Tokyo: University of Tokyo Press; 1987.
57. Zisman S, Reddan J, Schultz JB, McDaniel T. Structural and functional changes in catalase induced by near-UV radiation. *Photochem Photobiol* 1996;63:818–24.
58. Takisada M, Arakane K, Kaji K. Fluctuation of antioxidant enzymes in skin by UV-A irradiation. *J Soc Cosmet Chem Jpn* 1997;31:396–402.
59. Rhie G, Shin MH, Seo JY et al. Aging- and photoaging-dependent changes of enzymic and nonenzymic antioxidants in the epidermis and dermis of human skin *in vivo*. *J Invest Dermatol* 2001;117:1212–7.
60. Masaki H, Okano Y, Sakurai H. Differential role of catalase and glutathione peroxidase in cultured human fibroblasts under exposure of H₂O₂ or ultraviolet B light. *Arch Dermatol Res* 1998;290:113–8.
61. Masaki H, Sakurai H. Increased generation of hydrogen peroxide possibly from mitochondrial respiratory chain after UVB irradiation of murine fibroblasts. *J Dermatol Sci* 1997;14:207–16.
62. Gniadecki R, Thorn T, Vicanova J, Petersen A, Wulf HC. Role of mitochondria in ultraviolet-induced oxidative stress. *J Cell Biochem* 2000;80:216–22.
63. Masaki H, Atsumi T, Sakurai H. Detection of hydrogen peroxide and hydroxyl radicals in murine skin fibroblasts under UVB irradiation. *Biochem Biophys Res Commun* 1995;206:474–9.
64. Moshell AN, Bjornson L. Photoprotection in erythropoietic protoporphyria: Mechanism of photoprotection by beta carotene. *J Invest Dermatol* 1977;68:157–60.

65. Hasan T, Khan AU. Phototoxicity of the tetracyclines: Photosensitized emission of singlet delta dioxygen. *Proc Natl Acad Sci USA* 1986;83:4604–6.
66. Arakane K, Ryu A, Takarada K et al. Measurement of 1268 nm emission for comparison of singlet oxygen ($^1\Delta_g$) production efficiency of various dyes. *Chem Pharm Bull*. 1996;44:1–4.
67. Arakane K, Ryu A, Hayashi C et al. Singlet oxygen ($^1\Delta_g$) generation from coproporphyrin in *Propionibacterium acnes* on irradiation. *Biochem Biophys Res Commun* 1996;223:578–82.
68. Baier J, Maisch T, Maier M, Landthaler M, Bäumler W. Direct detection of singlet oxygen generated by UVA irradiation in human cells and skin. *J Invest Dermatol* 2007;127:1498–506.
69. Ryu A, Arakane K, Hayashi C et al. Peroxidation of skin surface lipids by singlet oxygen produced by *Propionibacterium acnes*. *J Jpn Cosmet Sci Soc* 1995;19:1–6.
70. Ryu A, Naru E, Arakane K et al. Cross-linking of collagen by singlet oxygen generated with UV-A. *Chem Pharm Bull* 1997;45:1243–7.
71. Naru E, Suzuki T, Moriyama M et al. Functional changes induced by chronic UVA irradiation to cultured human dermal fibroblasts. *Br J Dermatol* 2005;153(Suppl 2):6–12.
72. Ryu A, Arakane K, Koide C, Arai H, Nagano T. Squalene as a target molecule in skin hyperpigmentation caused by singlet oxygen. *Biol Pharm Bull* 2009;32:1504–9.
73. Darr D, Combs S, Dunston S, Manning T, Pinnell S. Topical vitamin C protects porcine skin from ultraviolet radiation-induced damage. *Br J Dermatol* 1992;127:247–53.
74. Miyachi Y, Horio T, Imamura S. Sunburn cell formation is prevented by scavenging oxygen intermediates. *Clin Exp Dermatol* 1983;8:305–10.
75. Danno K, Horio T, Takigawa M, Imamura S. Role of oxygen intermediates in UV-induced epidermal cell injury. *J Invest Dermatol* 1984;83:166–8.
76. Eberlein-König B, Placzek M, Przybilla B. Protective effect against sunburn of combined systemic ascorbic acid (vitamin C) and d-alpha-tocopherol (vitamin E). *J Am Acad Dermatol* 1998;38:45–8.
77. Ogura R, Sugiyama M. Active oxygen species and free radicals formed in the epidermis exposed to ultraviolet light. *J Act Oxyg Free Rad* 1992;3:270–7.
78. Dreher F, Maibach H. Protective effects of topical antioxidants in humans. *Curr Probl Dermatol* 2001;29:157–64.
79. Farris PK. Topical vitamin C: A useful agent for treating photoaging and other dermatologic conditions. *Dermatol Surg* 2005;31:814–7.
80. Lin JY, Selim MA, Shea CR et al. UV photoprotection by combination topical antioxidants vitamin C and vitamin E. *J Am Acad Dermatol* 2003;48:866–74.
81. Burgess C. Topical vitamins. *J Drugs Dermatol* 2008;7:s2–6.
82. Lin FH, Lin JY, Gupta RD et al. Ferulic acid stabilizes a solution of vitamins C and E and doubles its photoprotection of skin. *J Invest Dermatol* 2005;125:826–32.
83. Murray JC, Burch JA, Streilein RD, Iannacchione MA, Hall RP, Pinnell SR. A topical antioxidant solution containing vitamins C and E stabilized by ferulic acid provides protection for human skin against damage caused by ultraviolet irradiation. *J Am Acad Dermatol* 2008;59:418–25.
84. Wölflle U, Haarhaus B, Schempp CM. The photoprotective and antioxidative properties of luteolin are synergistically augmented by tocopherol and ubiquinone. *Planta Med* 2013;79:963–5.
85. Lee WC, Tsai TH. Preparation and characterization of liposomal coenzyme Q10 for *in vivo* topical application. *Int J Pharm* 2010;395:78–83.
86. Kang S, Chung JH, Lee JH. Topical N-acetyl cysteine and genistein prevent ultraviolet-light-induced signaling that leads to photoaging in human skin *in vivo*. *J Invest Dermatol* 2003;120:835–41.
87. Reeve VE, Widyarini S, Domanski D, Chew E, Barnes K. Protection against photoaging in the hairless mouse by the isoflavone equol. *Photochem Photobiol* 2005;81:1548–53.
88. Chiu TM, Huang CC, Lin TJ, Fang JY, Wu NL, Hung CF. *In vitro* and *in vivo* anti-photoaging effects of an isoflavone extract from soybean cake. *J Ethnopharmacol* 2009;126:108–13.
89. Berneburg M, Plettenberg H, Krutmann J. Photoaging of human skin. *Photodermatol Photoimmunol Photomed* 2000;16:239–44.
90. Tanaka K, Hasegawa J, Asamitsu K, Okamoto T. Prevention of the ultraviolet B-mediated skin photoaging by a nuclear factor kappaB inhibitor, parthenolide. *J Pharmacol Exp Ther* 2005;315:624–30.
91. Bond M, Baker AH, Newby AC. Nuclear factor kappaB activity is essential for matrix metalloproteinase-1 and -3 upregulation in rabbit dermal fibroblasts. *Biochem Biophys Res Commun* 1999;264:561–7.

92. Kitazawa M, Iwasaki K, Sakamoto K, Saliou C, Packer L. Redox system regulates UV induced-inflammation in human epidermal cells. *J Jpn Cosmet Sci Soc* 2000;24:168–71.
93. Onoue S, Kobayashi T, Takemoto Y, Sasaki I, Shinkai H. Induction of matrix metalloproteinase-9 secretion from human keratinocytes in culture by ultraviolet B irradiation. *J Dermatol Sci* 2003;33:105–11.
94. Kitazawa M, Iwasaki K, Sakamoto K, Saliou C, Packer L. Influence on AP-1 activation and MMP-1 expression by UV irradiation to human normal dermal fibroblasts. *J Jpn Cosmet Sci Soc* 2001;25:125–9.
95. Kligman AM, Grove GL, Hirose R, Leyden JJ. Topical tretinoin for photoaged skin. *J Am Acad Dermatol* 1986;15:836–59.
96. Aust O, Stahl W, Sies H, Tronnier H, Heinrich U. Supplementation with tomato-based products increases lycopene, phytofluene, and phytoene levels in human serum and protects against UV-light-induced erythema. *Int J Vitam Nutr Res* 2005;75:54–60.
97. Stahl W, Sies H. β -Carotene and other carotenoids in protection from sunlight. *Am J Clin Nutr* 2012;96:s1179–84.
98. Mizutani Y, Sakata O, Hoshino T et al. Preventive effects of carotenoids on photoaging and its application for cosmetics. *J Soc Cosmet Chem Jpn* 2005;29:9–19.
99. Bissett DL, Oelrich DM, Hannon DP. Evaluation of a topical iron chelator in animals and in human beings: Short-term photoprotection by 2-furildioxime. *J Am Acad Dermatol* 1994;31:572–8.
100. Brenneisen P, Wenk J, Klotz LO et al. Central role of ferrous/ferric iron in the ultraviolet B irradiation-mediated signaling pathway leading to increased interstitial collagenase (matrix-degrading metalloprotease (MMP)-1) and stromelysin-1 (MMP-3) mRNA levels in cultured human dermal fibroblasts. *J Biol Chem* 1998;273:5279–87.
101. Kitazawa M, Iwasaki K, Ishitsuka Y, Kobayashi M, Arakane K. Molecular design of a novel antioxidant for suppression of photoaging. *J Soc Cosmet Chem Jpn* 2001;35:149–54.
102. Mitani H, Naru E, Yamashita M, Arakane K, Suzuki T, Imanari T. Ergocalciferol promotes *in vivo* differentiation of keratinocytes and reduces photodamage caused by ultraviolet irradiation in hairless mice. *Photodermatol Photoimmunol Photomed* 2004;20:215–23.
103. Afaq F, Adhami VM, Ahmad N. Prevention of short-term ultraviolet B radiation-mediated damages by resveratrol in SKH-1 hairless mice. *Toxicol Appl Pharmacol* 2003;186:28–37.
104. Caddeo C, Teskac K, Sinico C, Kristl J. Effect of resveratrol incorporated in liposomes on proliferation and UV-B protection of cells. *Int J Pharm* 2008;363:183–191.
105. Lagouge M, Argmann C, Gerhart-Hines Z et al. Resveratrol improves mitochondrial function and protects against metabolic disease by activating SIRT1 and PGC-1 α . *Cell* 2006;127:1109–22.
106. Obayashi K, Kurihara K, Okano Y, Masaki H, Yarosh DB. L-Ergothioneine scavenges superoxide and singlet oxygen and suppresses TNF- α and MMP-1 expression in UV-irradiated human dermal fibroblasts. *J Cosmet Sci* 2005;56:17–27.
107. Widyarini S, Spinks N, Husband AJ, Reeve VE. Isoflavonoid compounds from red clover (*Trifolium pratense*) protect from inflammation and immune suppression induced by UV radiation. *Photochem Photobiol* 2001;74:465–70.
108. Buenger J, Driller H. Ectoin: An effective natural substance to prevent UVA-induced premature photoaging. *Skin Pharmacol Physiol* 2004;17:232–7.
109. Buonocore D, Lazeretti A, Tocabens Pet al. Resveratrol-procyanidin blend: Nutraceutical and anti-aging efficacy evaluated in a placebo-controlled, double-blind study. *Clin Cosmet Investig Dermatol* 2012;5:159–65.
110. Commission Directive 2005/9/EC, ANNEX VII—List of UV filters which cosmetic products may contain. Official Journal of the European Union, European Commission. Brussels, January 28, 2005.
111. Code of Federal Regulations—Title 21—Food and Drugs, Chapter 1, Subchapter D, Drugs for human use, Part 352—Sunscreen drug products for over-the-counter human use. U.S. Food and Drug Administration, Maryland, August 10, 2007.
112. Ministry of Health and Welfare Notification No.331 of 2000—Standards for Cosmetics. Ministry of Health, Labour and Welfare, Tokyo, September 29, 2000.
113. ISO. International standard ISO24444 cosmetics—Sun protection test methods—*In vivo* determination of sun protection factor (SPF). Geneva: ISO; 2010.
114. ISO. International standard ISO24442 cosmetics—Sun protection test methods—*In vivo* determination of sunscreen UVA protection. Geneva: ISO; 2011.

115. ISO. International standard ISO24443 cosmetics—Sun protection test methods—Determination of sun-screen UVA photoprotection *in vitro*. Geneva: ISO; 2012.
116. Commission of the European Communities. Commission recommendation of 22 September 2006 on the efficacy of sunscreen products and the claims made relating thereto. *Official J Euro Union* 2006;L265:39–43.
117. U.S. Department of Health and Human Services Food and Drug Administration. *Guidance for industry labeling and effectiveness testing: Sunscreen drug products for over the-counter human use—Small entity compliance guide*. Washington, DC: U.S. Department of Health and Human Services, Food and Drug Administration Center for Drug Evaluation and Research (CDER), December 2012.
118. The European Cosmetic Toiletry and Perfumery Association (COLIPA). *International sun protection factor test method*. Brussels: COLIPA; May 2006.
119. Bech-Thomsen N, Wulf HC. Sunbathers' application of sunscreen is probably inadequate to obtain the sun protection factor assigned to the preparation. *Photodermatol Photoimmunol Photomed* 1992–1993;9:242–4.
120. Stokes R, Diffey B. How well are sunscreen users protected? *Photodermatol Photoimmunol Photomed* 1997;13:186–8.
121. Neale R, Williams G, Green A. Application patterns among participants randomized to daily sunscreen use in a skin cancer prevention trial. *Arch Dermatol* 2002;138:1319–25.
122. Teramura T, Mizuno M, Asano H, Naito N, Arakane K, Miyachi Y. Relationship between sun-protection factor and application thickness in high-performance sunscreen: Double application of sunscreen is recommended. *Clin Exp Dermatol* 2012;37:904–8.
123. Balwani M, Desnick RJ. The porphyrias: Advances in diagnosis and treatment. *Blood* 2012;120:4496–504.
124. Tatebayashi M, Kawada A, Matsuo Y, Nakano H. A case of porphyria cutanea tarda. *Skin Research* 2014;13:382–6.

23

Topical Vitamins E, C, and Ferulic Acid and Topical L-Selenomethionine

Karen E. Burke and Doren Madey Pinnell

Introduction

As the largest and most exposed organ of our body, our skin suffers from exposure to solar ultraviolet (UV) radiation as well as direct contact with environmental pollutants. Fortunately, our skin has developed extraordinary mechanisms to protect from this cumulative free-radical damage, largely through elegant utilization of nutritional antioxidants.

During the past 20 years, dermatologic research has focused on how to deliver antioxidants successfully through topical application. This strategy has major rewards: higher levels of antioxidants can be delivered to the skin where they are most needed, and an indwelling reservoir of antioxidants that cannot be wiped, washed, or perspired away yields constant protection. However, the challenges of formulation are immense. (1) Antioxidants are naturally highly reactive. They react rapidly with oxygen free-radicals to protect cells and connective tissue from direct damage. (Think how quickly an apple darkens after it is sliced!) Thus, creating a formula that can maintain the stability of these labile molecules (possibly for many months as required for production, packaging, delivery, purchase, and use by the consumer) is a major challenge. (2) The antioxidant must successfully be absorbed transdermally while maintaining this stability. (3) The correct, active molecular form of the antioxidant must be used—not ester forms that, though stable, have little or no antioxidant activity (as in the case of vitamin C and vitamin E) and not mixed isomer forms when only one isomer is effective (as in the case of vitamin E).

This chapter discusses the unrecognized full extent of environmental damage, the necessity of topical antioxidants for protection, and the requirements for successful formulation to achieve topical delivery of the trace mineral selenium as well as vitamins C and E. The mechanisms of action for protection from and reversal of UV and other environmental damage are explained, and scientific proof of efficacy is presented.

Background

Cumulative Environmental Damage

More than our parents and grandparents, we expose our skin to environmental damage. We are much more likely to live in cities (with more environmental pollutants than the countryside), and we frequently travel to sunny climates and to high altitudes where UV exposure can be almost doubled by indirect reflection from water, sand, or snow. Our skin suffers—both with sunburn and tanning that lead to photoaging, with leathery texture, mottled pigmentation, wrinkles, and dryness and later with actinic keratoses and skin cancer. Our skin is further damaged directly by environmental pollutants (fossil fuels and cigarette smoke) and indirectly by the synergistic damage caused by the interaction of these pollutants with UVA.

Fortunately, the ozone and the oxygen in our atmosphere absorb all of the very dangerous, high energy UVC (wavelength < 290 nanometers [nm]) as well as most of the UVB (wavelength 290–320 nm). The radiation we experience is 5% UVB (the intensity of which varies with season) and 95% UVA (wavelength 320–400 nm) (the intensity of which is the same winter and summer). UVB penetrates the

epidermis; only a small amount actually reaches the dermal–epidermal junction. UVA penetrates the entire epidermis and dermis.¹

UVB directly damages DNA to form intrastrand pyrimidine dimers (i.e., thymine–thymine dimers).^{1,2} If repair mechanisms fail, the genome is permanently altered and mutations persist through subsequent cell divisions to initiate first precancers (actinic keratosis and dysplastic nevi) and later skin cancers (basal cell and squamous cell carcinomas as well as melanoma). UVB also damages the DNA indirectly by generating reactive oxygen species (ROS) that interact not only with DNA, but also with proteins and lipids.

The biologic effect of UVA radiation is primarily through indirect oxidative damage,¹ inducing ROS ($^1\text{O}_2$, singlet oxygen, the superoxide anion [$^{\cdot}\text{O}_2^-$], the peroxide anion of hydrogen peroxide, and the hydroxyl radical [OH^{\cdot}]), which generate mutagenic oxidative intermediates such as 8-hydroxydeoxyguanosine (8-OHdG) as well as pyrimidine dimers.³ This UVA-induced oxidative stress not only affects DNA, but also damages cell membranes and activates cell surface cytokines as well as cell surface growth factor receptors.⁴ Within 15 minutes of UV exposure of human skin to twice the minimal erythema dose (MED), epidermal growth factor (EGF), interleukin-I (IL-I), and tumor necrosis factor (TNF- α) receptors are activated on keratinocytes and fibroblasts,⁴ leading to stimulation of matrix metalloproteinase (MMP) gene activation. MMPs are then secreted to break down dermal collagen and elastic tissue directly, causing the wrinkling and crepey laxity of photoaged skin. Proinflammatory cytokine genes are also activated, amplifying the damage.⁵

UVA causes even more than photodamage to the dermis. Although UVB is primarily responsible for skin cancer, high doses of UVA1 (wavelength ~ 330 nm) alone can induce squamous cell carcinoma (SCC) in albino mice (after 431 days).⁶ Low doses of UVA have also been shown to promote melanomas initiated by UVB by modulating immune responses⁷ and/or by generating melanin free radicals.⁸ However, low doses of UVA alone do not cause skin cancer.

But that is not the whole story. More and more of us live in urban environments where low levels of pollutants (polycyclic aromatic hydrocarbons [PACs] such as benzo[a]pyrene [BaP]) are ubiquitous in the air, food, and water as a result of incomplete combustion of fossil fuels from power plants, automobile exhaust, heaters, and cigarette smoke. In our cities, the concentrations of these chemical pollutants are well below the toxic or tumorigenic levels.

When given orally, subcutaneously, or intratrachially, BaP does produce local skin and lung tumors (skin carcinomas and lung carcinomas, respectively).⁹ Also, smokers have twice the incidence of melanomas as compared to non-smokers, 1.5 times the incidence of squamous cell carcinomas,^{10,11} and 15 times the incidence of lip cancers.^{11,12} These observations suggest that there is synergy of cigarette smoking with UVA in causing oxidative damage to the skin. Cigarette smoke in combination with UV exposure definitely exacerbates the appearance of photoaging. Studies have demonstrated that heavy smokers (>20 cigarettes/day) are about five times more likely to have prominent wrinkles than non-smokers, especially around the eyes and mouth. As shown in Figure 23.1, the 52-year-old woman who smoked for many years has far more periorbital wrinkles than her 57-year-old non-smoking cousin.

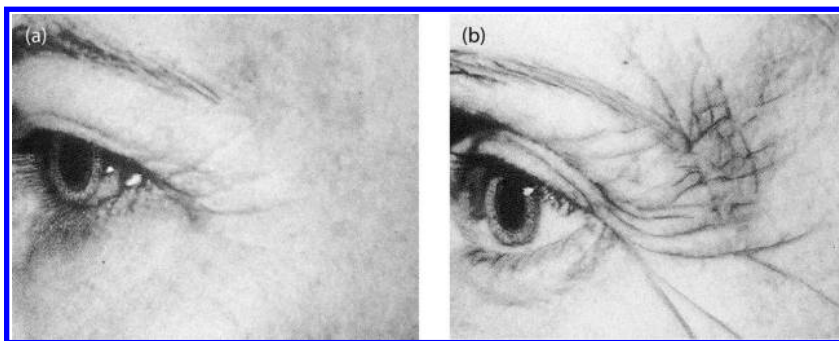

FIGURE 23.1 Increase in the wrinkles of photoaging from cigarette smoking. (a) A 57-year-old woman who does not smoke; (b) her 51-year-old cousin who smoked for many years. (Reproduced with permission of Mayo Foundation for Medical Education and Research. All Rights Reserved. Mayo Clinic Health Letters, January, 1987.)

TABLE 23.1**Synergistic Carcinogenesis: UVA + BaP**High dose of each alone is *carcinogenic*

BaP: 6–8 mg

UVA: 22,400 kJ/m²Low dose of each alone *not carcinogenic*Low dose of both together is *carcinogenic*

1/53 BaP + 1/8 UVA

Thus, as shown in Table 23.1, high doses of BaP (6–8 mg) alone or exposure to very high UVA (22,400 kJ/m²) alone can cause skin cancer. Low doses of each alone are not carcinogenic. However, simultaneous exposure to a low dose of each—1/53 the carcinogenic dose of BaP with 1/8 the carcinogenic dose of UVA—interact synergistically to become carcinogenic.¹³

Recent experiments have proven UVA can indeed interact synergistically with even low concentrations of environmental pollutants—not only to accelerate photaging, but also to increase skin cancer.^{13–16} In Skh:2 mice, topical application of BaP followed by UVA significantly increased skin tumor incidence and multiplicity compared to UVA- or BaP-treatment alone,¹⁵ as shown in Figure 23.2. No tumors developed in the groups treated with BaP or UVA alone. These studies demonstrate synergistic enhancement of skin tumorigenesis by BaP combined with UVA exposure.

Furthermore, *in vitro* experiments demonstrated that the interaction of BaP with UVA generates ROS such as H₂O₂, causing DNA damage, as measured by a large production of 8-OHdG.¹⁷ The amount of 8-OHdG correlates with BaP concentration and UVA dose. (In contrast, only a small increase is incited by BaP with UVB.) *In vivo*, BaP is metabolized to reactive intermediates (such as BaP diol epoxide (BPDE)¹⁸) which covalently bind to DNA, forming BPDE–DNA adducts that initiate carcinogenesis.¹⁵ In experiments simulating environmental carcinogens and sunlight by topical application of BaP followed by UVA radiation, these BPDE–DNA adducts were detected by immunohistochemistry in the skin *in vivo*.¹⁸ This genetic damage increases the potential for induction of cancer.^{13–15}

The possible mechanisms for the synergistic increase in oxidative damage by BaP plus UVA are summarized in Figure 23.3:^{13,15} (1) BaP and its intermediates may be photosensitizers for UVA,¹⁹ producing more ROSs that (a) mutate DNA by forming 8-OHdG and (b) promote carcinogenic cell proliferation; (2) UVA interacts with environmental BaP to form BPDE–DNA adducts that directly cause genetic mutations, leading to carcinogenesis.

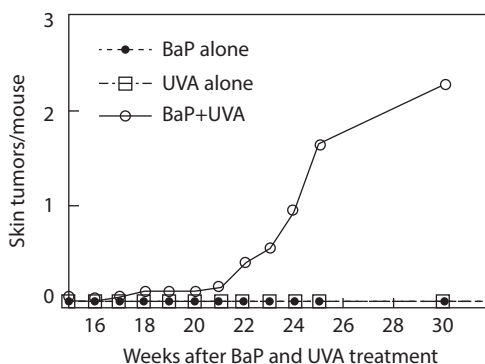

FIGURE 23.2 The skin tumor multiplicity in mice after topical application of 8 nmol of BaP and exposure to 40 kJ/m² of UVA thrice weekly for 25 weeks. Treatments were discontinued at week 25, and mice were observed for another five weeks before being sacrificed. (From Wang Y, Saladi R, Wei H. *Trends Photochem Photobio* 2003;10:31–45.)

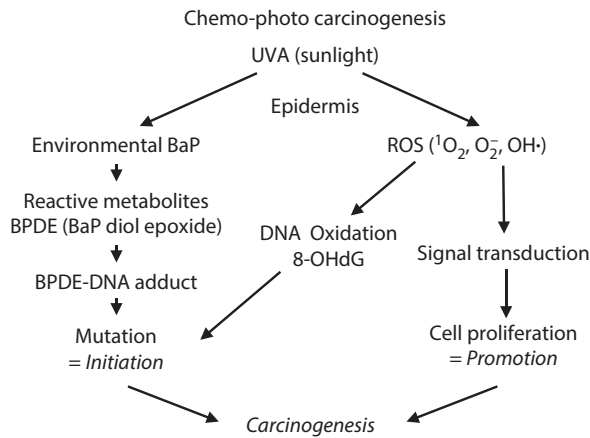

FIGURE 23.3 Mechanisms of synergy in chemo-photocarcinogenesis. (Modified from Saladi R et al. *Photochem Photobiol* 2003;77:413–9.)

Sunscreen Is Not Enough

The only indisputable way to prevent photoaging and almost all skin cancer is to eliminate sun exposure (and take vitamin D to compensate for the required sun-induced synthesis). Certainly sunscreens are absolutely essential for protection, but there are many limitations in their efficacy, as enumerated in Table 23.2. The sunscreen *formulation* must protect from UVA as well as UVB and be highly water-resistant so that it is not washed off by perspiration or when swimming. *Proper application* is absolutely essential and very difficult to accomplish. In order to attain the sun protection factor (SPF) stated on the label, 2 mg/cm² must be applied every 90 minutes! This means that each application to a bathing suit-clad body requires about one and one-half 4-oz bottles, so about six bottles are needed for a 10 a.m. to 5 p.m. day at the beach. Individuals usually apply only one-fourth of this required amount (0.5 mg/cm²), thus making a sunscreen labeled “SPDF 30” sunscreen effectively only SPF 2.3. Many individuals skip application to important areas around the eyes, under the nostrils, in front of and on the ears, as well as on the fingertips, ankles, and feet, and men (as well as women) forget areas with thinning hair on the scalp. Since SPF is only a measure of UVB protection, sunscreen users often have a false sense of security and stay longer in the sun, thereby exacerbating especially UVA damage. Because UVA is equally strong in winter and summer, and *does* penetrate window glass, sunscreen must be applied during all seasons as well as when indoors.

Finally, sunscreens *cannot fully protect* the skin from the environment: they block only about 55% of free radical production,^{20,21} and they do not shield from the environmental BaPs described previously.

TABLE 23.2

Limitations of Sunscreens

1. Difficulties in complying with requirements of application
 - Must apply each 90 min
 - Must apply 2 mg/cm² to attain SPF stated; most individuals who apply *generously*, can only apply 0.5 mg/cm², making the labeled SPF = 30 only effectively SPF = 2.3
 - Must apply without skip areas
 - Must apply winter and summer, inside and outside (since UVA does not change seasonally and does penetrate window glass)
2. Broad-spectrum sunscreen decreases free radicals only by 55%
3. Sunscreen does not protect against other environmental free radicals

Advantages of Topical Antioxidants

There are two great advantages in applying an active formulation of topical antioxidant(s) to the skin. First, the skin attains far higher levels of each antioxidant than can be achieved by only taking these supplements orally.²² For example, the level of vitamin C attained in the skin by topical application is 25–40 times the level achievable with oral vitamin C²²; with topical application, the concentration of vitamin E increases by a factor of 10.6,²³ and selenium, by a factor of 1.7.^{24–26} Second, topical application arms the skin with a reservoir of antioxidant(s) that cannot be washed or rubbed off, a protection which stays in the skin even for several days after application.²²

The research described below confirms that topical application of antioxidant(s) can indeed offer exciting new possibilities in protecting the skin from UV and other environmental damage—not only to reduce extrinsic photoaging, but also to decrease the incidence of skin cancer. These advantages can be achieved with no adverse reactions.

Topical L-Selenomethionine

Selenium (Se) was recognized to be an essential trace element in humans and animals in the late 1950s. Se is a specific component of important selenoproteins and Se-dependent enzymes required for antioxidant defense, reduction of inflammation, as well as thyroid hormone production and many other metabolic functions.^{27,28} Se is also essential for optimal humoral and cellular immunity.^{29,30} This trace mineral can be converted to Se metabolites that have been shown to reduce the blood supply to tumors and to kill cancer cells.³¹ Se may even prevent cancer metastases by anti-angiogenesis, cell cycle arrest, and apoptosis of tumor cells, inhibition of local invasion and migration, and enhancement of carcinogen-detoxifying enzymes.^{32,33}

Because previous epidemiological studies^{34–36} showed an inverse correlation between soil Se levels and cancer mortality rates, and several early, retrospective case studies detected significant inverse correlations of the incidence of internal neoplasms with blood Se concentrations,^{36–39} correlations with skin cancer incidence were investigated. Indeed, patients with malignant melanoma were found to have significantly lower levels of serum Se, and patients with more advanced disease (stage III disseminated melanoma) had the lowest levels.⁴⁰ In a transgenic mouse model, topical treatment with L-selenomethionine (SeMet) resulted in a significant delay in the time required for melanoma development (though established tumors grew more rapidly).⁴¹ Patients with cutaneous lymphoma (Sezary syndrome as well as mycosis fungoides) were found to have decreased serum titers of Se, and stages III and IV had significantly lower levels than the earlier stages I and II.⁴⁰ Also, the patients with Sezary syndrome or mycosis fungoides who responded less well to therapy were found to have lower levels of Se.⁴⁰ These observations led to a retrospective study of 240 non-melanoma skin cancer patients who were found to have a significantly lower mean plasma Se concentration than control subjects without skin cancer.⁴² In fact, those patients whose blood concentrations were in the lower decile had 4.4 times the incidence of non-melanoma skin cancer as those in the highest decile.⁴²

These positive correlations were followed by an extensive prospective 10-year, double-blind study (the Nutritional Protection of Cancer [NPC] Trial) on 1312 patients who had a prior history of at least two basal cell and/or one squamous cell carcinoma.⁴³ Oral supplementation with either 200 µg/day SeMet or placebo demonstrated a dramatic decrease in cancer mortality and total cancer incidence (to only 50% and 63%, respectively, compared with non-supplemented patients). Particularly large decreases in prostate cancer (to 37%), colon–rectal cancer (to 42%), and lung cancer (to 55%) were observed.⁴³ Unfortunately, in the NPC trial the number of new basal cell or squamous cell carcinomas increased minimally (by 10%).⁴³ Since the patients in this study were chosen precisely because of their past history of skin cancer (indicating extensive solar damage), this lack of protection suggests that the degree of damage at the onset was so severe that reversal of oncologic potential is not possible.

Thus, with some evidence indicating that Se might protect against UV-induced skin cancer, mouse studies were undertaken to investigate this possibility.^{24,25} Previous oral selenium selenite showed

protection against UV-induced skin cancer in mice,⁴⁴ but this supplementation resulted in adverse effects (failure to thrive); furthermore, our preliminary experiments demonstrated that the selenite could not be absorbed percutaneously. Topical Se has been used effectively in lotions containing Se sulfide (2.5%) for the treatment of tinea versicolor (a common superficial fungal infection of the skin)⁴⁵ and in other lotions and shampoos (at concentrations of 1.0%–2.0%) for the treatment of seborrheic dermatitis and dandruff^{46,47}; however, this sulfide compound of Se is also not absorbed percutaneously.⁴⁷ SeMet was chosen as the source of Se for topical delivery because it is effectively absorbed percutaneously, unlike the other sources of Se, even those used in available dermatologic formulations.⁴⁸

Within the body, Se is found in eleven selenoenzymes (including five glutathione peroxidases [GPxs], three thioredoxin reductases [TDRs], three iodothyronine deiodinases [DIOs]), and 14 selenoproteins.²⁸ The GPxs catalyze the reduction of hydrogen peroxide and lipid hydroperoxides; TDR prevents UV oxidation of thioredoxin, which would otherwise increase synthesis of dihydroxyphenylalanine, the precursor of melanin.^{49,50} Thus, the GPxs protect against ROS and TDRs decrease UV-induced hyperpigmentation. Supplementing the skin with SeMet has the further advantage in that SeMet itself can act directly as a scavenger for damaging reactive-oxygen species (ROS).⁵¹ In the mouse studies that were undertaken,^{24,25} topical as well as oral SeMet were found to protect against acute UVB damage (blistering, sunburn, erythema, and tanning); both forms also effectively decreased the incidence and the multiplicity of UVB-induced skin cancers and the time of onset was delayed. Topical application of SeMet increased the concentration of Se in the skin by a factor of 1.7. Se levels were also elevated in the liver by topical application, proving successful transdermal absorption.

Thus, topical SeMet has been proven to be effective in protecting against acute and chronic UV damage to the skin. Concentrations as low as 0.02% increased the minimal erythema dose (MED) in humans and decreased acute erythema and blistering as well as later UV-induced tanning, though 0.05% is optimal.⁵²

Furthermore, topical SeMet is highly effective not only in preventing but also in reversing the appearance of photoaging. Because topical SeMet penetrates transdermally, both the epidermis and dermis are protected, so previous damage can be repaired. As a cofactor in the GPxs, Se quenches ROS, thus decreasing inflammation and preventing activation of mediators which induce the metalloproteinases (MMPs) that would otherwise degrade collagen and elastic tissue; thereby, wrinkles are reduced. As a cofactor for TDR, melanin synthesis is inhibited and solar hyperpigmentation is corrected.^{49,50} This correction of the appearance of photoaging can be seen in Figure 23.4: After four months of once daily application of SeMet (0.05%) cream, this 56-year-old woman's periorbital rhytides are decreased significantly.

This enhancement of repair of chronic photoaging was confirmed at the cellular and molecular level by histologic and electron microscopic analysis in mice.⁵³ UV-induced hyperkeratosis and epithelial hyperplasia markedly decreased; irregular, damaged collagen was replaced with newly synthesized, fine

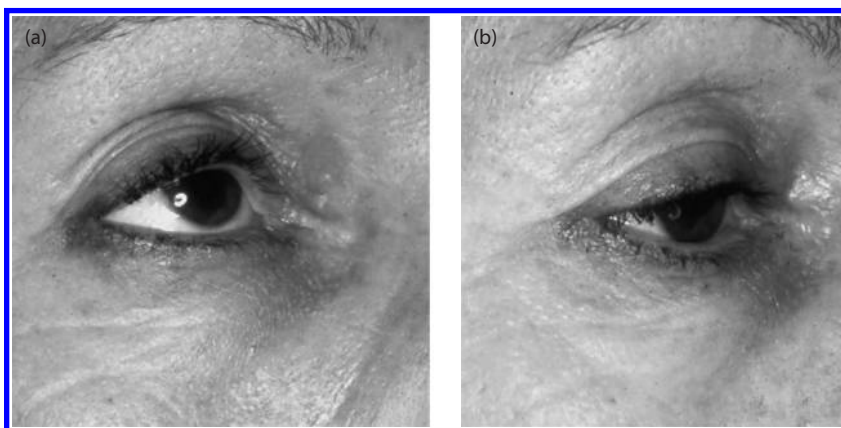

FIGURE 23.4 Correction of periorbital wrinkles with four months of once-daily treatment with 0.05% L-selenomethionine lotion: (a) before treatment; (b) after treatment.

fibrillar homogeneous collagen; solar elastosis was repaired; and UV-induced inflammation resolved—all more effectively than comparable treatment with topical tretinoin.⁵³ Electron microscopy confirmed repair of dermal collagen and showed repair of basement membrane anchoring fibrils (which are degraded by UV exposure).⁵³

Vitamin E

Discovered in 1922 by Evans and Bishop as a dietary factor required for rat reproduction,⁵⁴ vitamin E is the most abundant antioxidant in the skin and the most important lipid-soluble, membrane-bound antioxidant in the body. Its role as an antioxidant was suggested when animals made ill by ingesting rancid fat could be cured with wheat germ oil concentrates containing tocopherols.^{55,56} Vitamin E is the generic name of a mixture of lipid-soluble phenols, tocopherols and tocotrienols—the structures (shown in Figure 23.5) feature an aromatic chromanol head and a 16-carbon hydrocarbon tail. The number of methyl substituents on the chromanol ring gives rise to α , β , γ , and δ isomers, whereas saturation of the hydrocarbon chain defines the tocopherol form (with a saturated chain, constituting eight stereoisomers of each of the four isomers of tocopherol) or the tocotrienol form (with an unsaturated chain and two stereoisomers of each of the four tocotrienol isomers).⁵⁷

The biologic activity of vitamin E generally has been believed to be due to its antioxidant action of inhibiting lipid peroxidation by scavenging the chain-propagating peroxy radicals (ROO^{\cdot}) in biological membranes, thereby eliminating the chain reaction of fatty acid radical propagation.^{58,59} Recent research has further demonstrated that vitamin E also modulates receptors (such as the low-density lipoprotein receptor) and is a cell signaling molecule for transcription factors that regulate target genes connected to antioxidant defense, inflammation, cell cycle regulation, extracellular matrix, cytoarchitecture, lipid uptake, and cholesterol synthesis.^{60,61} Taber and Atkinson⁵⁹ propose that vitamin E does not directly modulate these signaling pathways, but rather that oxidative stress alters membrane fluidity or specific lipids, both of which can, in turn, modulate the receptors and signaling pathways. These researchers propose that vitamin E's sole biologic role is as an antioxidant to protect polyunsaturated fatty acids and membrane fluidity and lipid domains.⁵⁹

The efficacy of the tocopherols in comparison with the tocotrienols is currently under investigation in many laboratories. Because there are diverse *in vitro* and animal models, it is difficult to estimate the

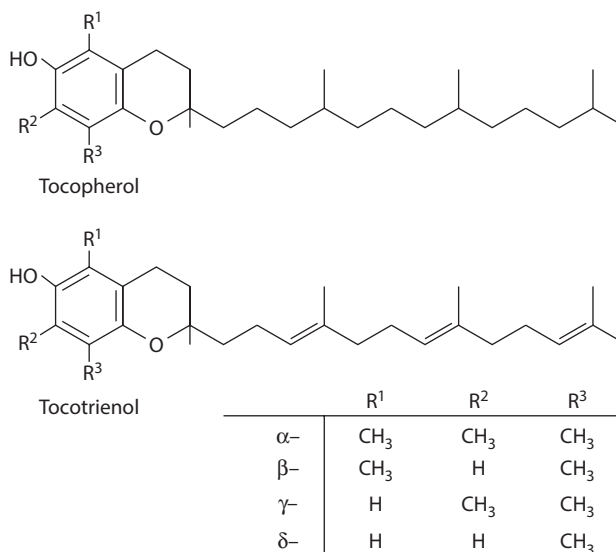

FIGURE 23.5 Chemical structures of vitamin E.

physiologic importance and health benefits to humans from these different investigations. Also, the efficacy of each isomer and form of vitamin E depends upon many parameters: (1) genetic variability among individuals in absorption, distribution, and metabolism, (2) absorption (either gastrointestinal or percutaneous), (3) affinity and efficacy of transport by the specific α -tocopherol transfer protein (α -TTP) (which has a highest affinity for d- α -tocopherol), (4) tissue distribution, and (5) metabolism within each tissue.

It is generally believed that the tocotrienols exhibit stronger antioxidant activity when compared to the tocopherols.⁶² Although past epidemiological studies, as well as *in vivo* and *in vitro* studies, indicate vitamin E intake has protective properties against carcinogenesis,^{63–66} some recent studies on vitamin E show the contrary.^{67–69} The largest vitamin E randomized trial to date, selenium and vitamin E Cancer Prevention Trial (SELECT), indicated that α -tocopherol supplementation increased prostate cancer incidence.⁷⁰ However, the seemingly contradictory results of the SELECT trial should not discourage the use of vitamin E as a protective agent, but rather should be an indicator of the complexities of vitamin E.⁷¹ Possibly this contradictory data will be resolved if studies on specific isomers (α , β , γ , δ) and stereoisomers are undertaken. Not all isoforms are created equal!

The natural vitamin E isoform, nonesterified RRR- α -tocopherol (or d- α -tocopherol) is preferentially transported by α -TT in most mammalian tissues⁷² and is preferentially incorporated into lipoproteins^{73,74} and maintained in plasma,⁷⁵ while all other stereo and isoforms are quickly excreted or metabolized.^{74,76} Relative to the α form, the β , γ , and δ RRR-tocopherols give only 42%, 72%, and 40%, respectively, protection against post-UV edema.⁷⁷ The synthetic form is “dl” or “all-*rac*,” a mixture of eight stereoisomers. The synthetic isomers are esterified (to acetates and succinates) for use in commercial vitamins and some topical formulations because the esters are far more stable. However, this ester must be hydrolyzed before any biologic activity is possible, a reaction which readily occurs in the stomach after oral ingestion or in cell and organ culture, but is very slow after topical application. The skin has only a limited capacity to cleave the esterified forms of vitamin E to the active free tocopherol form, so the antioxidant potential of the esters is minimal.^{78,79} Furthermore, the all-*rac* form of vitamin E has been reported to cause allergic contact dermatitis,^{80,81} folliculitis,⁸² and one case of erythema multiforme⁸³ when applied topically. No such adverse reactions have ever been reported with d- α -tocopherol.

Vitamin E is especially abundant in stratum corneum, delivered there by sebum.^{84,85} Its concentration is highest at the lower levels of the stratum corneum, with a decreasing gradient outward. As the outermost defense of the body, the stratum corneum is first to absorb the oxidative stress of sunlight and pollution. Vitamin E is depleted with this exposure: a UV dose of 10 \times minimal erythema dose (MED) depletes vitamin E only by 4%,⁸⁶ but ozone potentiates this depletion.⁸⁷ Exposure to high amounts of ozone (10 ppm/3 hours, more than the pollution in any city) decreases the concentration of vitamin E by 22%, and increases the malonyldialdehydes (MDAs, an indicator of ROS levels) by a factor of 10.⁸⁷ Therefore, topical application of vitamin E is particularly advantageous, especially since the lipophilic structure makes it cosmetically attractive for application and absorption.

Previous studies have demonstrated protection from the *acute*^{88–93} UV-induced damage of inflammation (erythema, “sunburn”) and hyperpigmentation (tanning), as well as protection from the *chronic* UV-induced damage of skin cancer,^{93–98} even by the various forms of vitamin E, which are less metabolically potent when applied topically than the nonesterified d- α -tocopherol. Topical d- α -tocopherol was shown to be far more effective in protecting against all acute and chronic UV-induced damage than topical d- α -tocopheryl succinate in mice, and more protective than oral d- α -tocopheryl acetate.⁹⁹ In other mouse studies, topical α -tocopheryl succinate and α -tocopheryl acetate not only failed to inhibit UVB-induced immunosuppression and carcinogenesis, but actually appeared to enhance carcinogenesis.⁷⁸ Topical α -tocopheryl acetate was less effective than α -tocopherol against UV-induced erythema in rabbits^{78,100} and against UV-induced photoaging in mice¹⁰¹.

Topical d- α -tocopherol has been demonstrated to reverse photoaging dramatically. [Figure 23.6](#) shows the improvement in periorbital rhytides in a 48-year-old woman after four months of daily topical application of d- α -tocopherol (5%). After eight weeks of topical treatment in mice, histologic examination confirmed correction of the UV-induced epidermal hypertrophy with thickened stratum corneum, increased incidence of damaged “sunburn cells” in the basal layer, and disruption of dermal collagen and elastin (Burke KE, Riciotti L, Gross EG, unpublished observation). Further electron microscopic

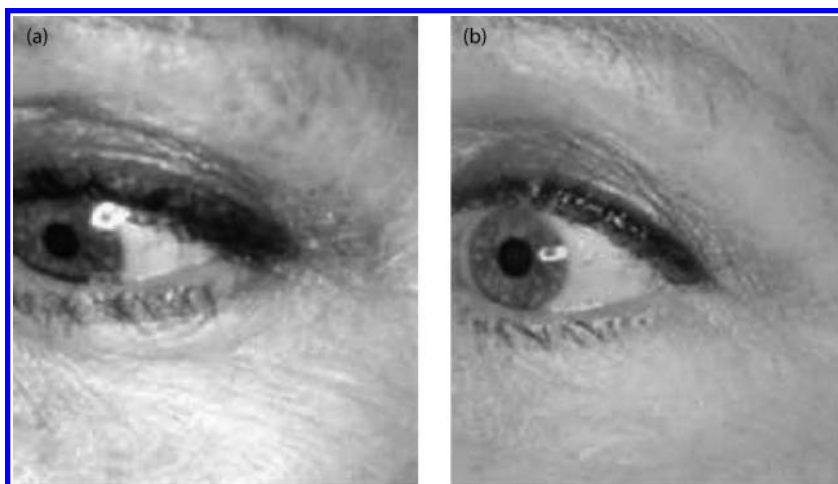

FIGURE 23.6 Correction of periorbital wrinkles with four months of once-daily treatment with 0.05% d- α -tocopherol cream: (a) before treatment; (b) after treatment.

analysis confirmed correction of collagen and elastin fiber damage and demonstrated repair of UV-induced disruption of the basement membrane anchoring fibrils.

Vitamin C

Vitamin C is possibly the most well-known vitamin in the world. In one of the first controlled experiments in history by a surgeon of the British Royal Navy, James Lind proved in 1747 that giving sailors lime or lemon juice prevented the dreaded, lethal disease of scurvy. It took the British Royal Navy until 1795 to include lime or lemon in sailors' rations (leading to their nicknames "limies").

Vitamin C was first isolated from fruit in 1928 by Albert Szent-Györgyi, who described its extraordinary effects in improving human health. In the 1970s, Linus Pauling recommended far larger doses than possible through nutrition alone to attain optimal health.¹⁰² (Dr. Pauling himself took 13 g/day, since that is the amount synthesized per day by a 130-lb goat.)

Only primates, guinea pigs, and the Indian fruit-eating bat lack the enzyme (L-glucono-gamma-lactone oxidase) required to self-synthesize vitamin C. Vitamin C (L-ascorbic acid) is the body's major aqueous-phase antioxidant and is essential for life. We humans get vitamin C solely from our diet, but even large doses (6000 mg/day, or 80 oranges) do not increase the concentration to optimal levels in the skin. Furthermore, exposure to sunlight and environmental pollution deplete vitamin C from the center layers of the skin. Even minimal UV exposure of 1.6 minimal erythema dose (MED) decreases the level of vitamin C to 70% of the normal level, and exposure to 10 MED decreases the vitamin C to only 54%.⁸⁶ Exposure to ozone at a dose of 10 parts per million in city pollution decreases the level of epidermal vitamin C by 55%.⁸⁷

Active L-ascorbic acid is such an excellent antioxidant that it is inherently unstable, turning brown as it is oxidized to dihydroascorbic acid when exposed to air. Therefore, the shelf life of most formulations containing pure vitamin C is short, so esterified forms of vitamin C are usually used for topical application in lotions, creams, serums, and patches to overcome this problem. However, these more stable, esterified derivatives (ascorbyl-6-palmitate and magnesium ascorbyl phosphate) are not well absorbed¹⁰³ and are only minimally metabolized by the skin to the active, free acid form. To achieve photoprotection and other benefits to the skin with topical vitamin C, the formulation must contain L-ascorbic acid in a high enough concentration (at least 10%), be stable, and be at an acid pH—less than the pKa (4.2) of vitamin C.¹⁰³ (The optimal pH is 3.5.)

If these criteria are met, effective skin levels of active vitamin C can be attained. Topical absorption has been proven by radioactive labeling studies in pigs.¹⁰³ After treatment with 10% vitamin C cream, 8.2% was found in the dermis, and 0.7% was in the blood.¹⁰³ Concentrations of 5%, 10%, 15%, 20%, or 25% vitamin C were tested: 20% resulted in the highest skin levels, with maximized concentration in the skin after three days of once-daily application.²² In these experiments, levels of vitamin C after topical application of 15% serum were shown to be a factor of about 27 times that which could ever be attained by even very high oral intake. If topical application is discontinued after skin saturation is achieved, high levels remain in the skin for more than three days.²²

Vitamin C has been proven to be photoprotective. Vitamin C is itself not a sunscreen since it does not absorb light in the UV spectrum. However, as an antioxidant vitamin C deactivates UV-induced free radicals and decreases UVB erythema by 52%.¹⁰³ This protection has been confirmed histologically; treatment with topical 10% vitamin C decreased the number of abnormal “sunburn cells” by 40%–60% and reduced the UV damage to DNA 8-hydroxydeoxy guanosine (8-OHdG) by 62%.¹⁰³

Vitamin C is absolutely necessary for the health, indeed the existence, of skin, because it is the essential cofactor for the two enzymes required for collagen synthesis, prolyl hydroxylase (which makes the collagen molecule stable), and lysyl hydroxylase (which cross-links the collagen to give structural strength).¹⁰⁴ Recent research has further demonstrated that vitamin C acts directly on DNA to increase the transcription rate and to stabilize the procollagen messenger RNA, thus regulating and maintaining the intercellular amount of collagen.¹⁰⁵

By regulating collagen synthesis, vitamin C can directly prevent the collagen loss that causes wrinkles in the young and restores the collagen in older individuals. Exciting studies *in vitro* compared newborn with elderly (80–95-year-old) fibroblasts.¹⁰⁶ As shown in Figure 23.7, elderly cells proliferated *in vitro* at only one-fifth the rate of newborn cells. However, when vitamin C was added to the culture medium, the elderly cells actually proliferated better than normal newborn fibroblasts. Even the newborn fibroblasts proliferated almost four times better when exposed to vitamin C.¹⁰⁶

Not only did fibroblasts increase proliferation in the presence of vitamin C, they also synthesized more collagen. Newborn fibroblasts synthesize a larger percentage of collagen than elderly cells; but again, when elderly cells were exposed to vitamin C *in vitro*, they produced more collagen than the normal, newborn fibroblasts.¹⁰⁶ Surprisingly, the newborn cells also doubled the amount of collagen synthesized.¹⁰⁶ Thus, supplementing the skin with extra vitamin C can not only combat the collagen destruction of photodamage, it can correct the loss (of about 1% per year) which occurs with natural, intrinsic aging (after approximately 45 years of age).

In contrast to the increased synthesis of collagen, other *in vitro* studies suggested that vitamin C may inhibit elastin biosynthesis by fibroblasts.¹⁰⁷ This might be advantageous in reducing the solar elastosis due to photodamage.

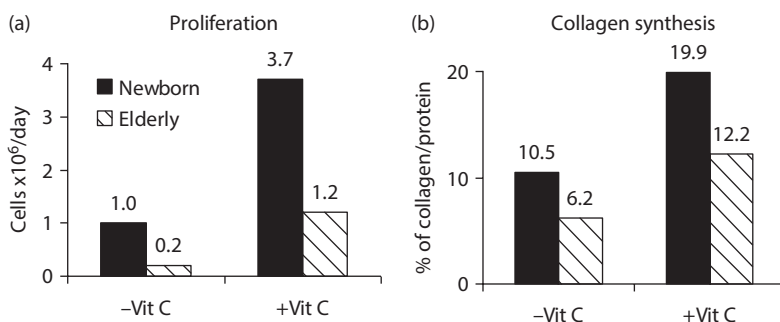

FIGURE 23.7 Antiaging effects of vitamin C on newborn and elderly fibroblasts *in vitro*. (a) Increased fibroblast proliferation; (b) Increased synthesis of collagen. Newborn fibroblasts (isolated from circumcised skin) and elderly fibroblasts (obtained from biopsies of individuals >90 years old) were grown *in vitro* with and without 10% L-ascorbic acid added to the culture medium. Fibroblast proliferation rate and synthesis of collagen per cell were measured. Solid bar = neonatal fibroblasts; striped bar = >90-year-old fibroblasts. (These graphs are representations of data from Phillips CL, Combs SB, Pinnell SR. *J Invest Derm* 1994;103:228–32.)

Topical vitamin C has also been shown to enhance collagen production in human skin *in vivo*. Postmenopausal women who applied 5% vitamin C to one arm and half of the neck with placebo to the other side showed an increase in mRNA of collagens I and III.¹⁰⁸ Tissue levels of the inhibitor of metalloproteinase-I (MMP-I) were also increased, thus decreasing UV-induced collagen breakdown. However, mRNA levels of elastin, fibrillin, and tissue inhibitor of MMP-2 remained unchanged. Clinically, a significant decrease was observed in deep furrows and substantiated by silicone replicas. Histology showed elastic tissue repair.¹⁰⁸ Other studies demonstrated a decrease in the crepey laxity of forearm skin, with restoration of a younger skinfold pattern after six months of once-daily treatment with 15% vitamin C.

Topical vitamin C is also directly anti-inflammatory. Application of vitamin C applied before and after CO₂ laser surgery reduced post-surgery erythema and cut healing time by one-half.¹⁰⁹ Topical vitamin C can also effectively treat the inflammation of rosacea.¹¹⁰ This anti-inflammatory action has been researched *in vitro* with human cells in vitamin C-enriched media, demonstrating decreased activation of the transcription factor nuclear factor $\kappa\beta$ (NF- $\kappa\beta$), the factor responsible for many pre-inflammatory cytokines such as tumor necrosis factor- α (TNF- α) and interleukins IL-1, IL-6, and IL-8.¹¹¹

By directly decreasing inflammation, post-inflammatory hyperpigmentation can also be reduced. Vitamin C is itself an excellent depigmenting agent because it inhibits the enzyme tyrosinase required for melanin production.¹¹² Melasma and solar lentigines fade after only two months of daily application of topical vitamin C (15%) (KEB, personal observation).

Kameyama et al.¹¹³ demonstrated suppression of melanin formation by inhibiting tyrosinase in melanocytes and in melanoma cells by 10% magnesium-L-ascorbyl-2 phosphate applied to human skin. Significant lightening of melasma and of solar lentigines was observed in 19 of 34 patients.¹¹³

Topical vitamin C has also been shown to increase the synthesis of several specific sphingolipids of the skin surface.¹¹⁴ With these lipids, vitamin C helps the natural moisturization of the skin as it enhances the protective barrier function (Catiel-Higournenc Ferrais C, Guey C, Schmidt R et al. L'Oréal Advanced Research Laboratories, Clichy and Aulnay-sous-Bois, France; personal communication).

Vitamin C + E

Vitamins C and E act synergistically within cells to provide antioxidant protection: vitamin E is located in the cellular membranes and vitamin C is plentiful in the neighboring aqueous cytoplasm. With a lower redox potential, vitamin C can reduce the oxidized vitamin E, thereby regenerating vitamin E activity and eliminating the need for nutritional replacement.¹¹⁵ Similarly, when vitamin C is oxidized to neutralize free radicals in the aqueous cytoplasm, vitamin E helps stop the free radical cascade. In high doses, vitamin C with vitamin E can protect against UV-induced erythema in humans,^{116,117} whereas either vitamin alone is ineffective.¹¹⁷ Formulating L-ascorbic acid (15%) with α -tocopherol (1%) was found to give fourfold protection against UV-induced erythema in porcine skin. A decrease in the number of damaged "sunburn cells" was seen histologically, as well as a decrease in thiamine dimer formation¹¹⁸ compared to twofold protection for either vitamin alone. This protection from UV-induced erythema¹¹⁹ and tanning¹²⁰ by vitamins C and E was further demonstrated in humans in a formulation also containing melatonin.¹¹⁹ Mixing hydrophilic vitamin C with lipophilic vitamin E has the additional advantage of stabilizing each.¹¹⁸ This formulation for topical application is cosmetically attractive and moisturizing.

The formulation of vitamin C (15%) and vitamin E (1%) proved to be highly effective in preventing UVB-induced skin cancer in mice.¹²¹ The mice were treated once daily (five days/week) for two weeks prior to exposure to UVB (three times a week for 22 weeks) and throughout the experiment of 35 weeks. One group of 15 mice was treated with vehicle serum and the other with antioxidant serum—vitamin C (15%) + vitamin E (1%). Amazingly, only one tumor was seen in the antioxidant-treated group, whereas the vehicle-treated group had a total of 195 tumors. To compare these figures with data from a similar experiment (vitamin E), after 40 weeks of observation the group of 15 vehicle-treated mice had 67 tumors cumulatively and the 15 d- α -tocopherol-treated mice had 36 tumors.²³ Although this demonstrated excellent protection by vitamin E, the results are not as impressive as the combination with vitamin C. Other new formulations with vitamins C and E in microsomes or in microemulsions are equally impressive in protecting against UV-induced sunburn, tanning, and skin cancer.¹²¹

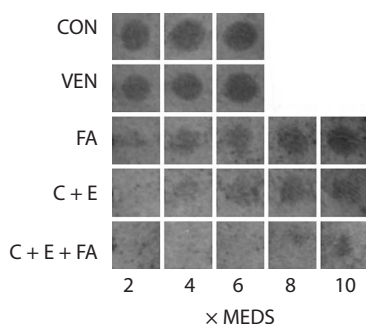

FIGURE 23.8 Inhibition of UV-induced erythema by topical antioxidants. Human volunteers were irradiated with UVA + UVB on their backs by a solar-simulator, 2× to 10× MED at 2×-MED intervals, after application once daily for four days of the following topical antioxidant formulations (2 mg/cm²): none (control [CONT]), vehicle (VEH), ferulic acid (0.05%) (FA), combination vitamin C (15%) and vitamin E (1%) (C + E), and combination vitamin C (15%) and vitamin E (1%) and ferulic acid (0.05%) (C + E + FA). Erythema, as shown above, was determined one day later. (Reproduced here with permission of SkinCeuticals.)

Vitamin C + E + Ferulic Acid

Ferulic acid is found ubiquitously and at high concentrations in plants,^{122–124} where it cross-links polysaccharides and proteins during lignin cell wall synthesis.¹²⁵ Ferulic acid is a potent antioxidant, so it further protects membranes from lipid peroxidation and neutralizes alkoxy and peroxy radicals. It also has been shown to interact synergistically with α -tocopherol and with ascorbic acid.¹²⁶ Unlike vitamins C and E, ferulic acid itself minimally blocks UVB, directly acting as a sunscreen, as seen in Figure 23.8.

Zielinski and Pinnell¹²⁷ tested the effectiveness of a series of low molecular weight antioxidants that are available in chemically pure form. Ferulic acid was found to provide stability of more than 90% for L-ascorbic acid and 100% for α -tocopherol. Addition of ferulic acid (optimally 0.5%) to the formulation of vitamin C (15%) + vitamin E (1%) doubled the photoprotection against solar-simulated irradiation of skin from fourfold to approximately eightfold, as measured by both erythema (with a substantial increase in the MED, as shown in Figure 23.8) and a decrease in sunburn cell formation.^{128,129}

Enhanced photoprotection was further demonstrated immunohistochemically by inhibition of UV-induced formation of thymine dimer mutations and of UV-induced p53, both of which are associated with skin cancer. Evaluation by real-time polymerase chain reaction demonstrated suppression of UV-induced cytokine mRNA formation (for inflammatory cytokines IL-1 α , IL-6, IL-8, and TNF- α , as well as for the immunosuppressive cytokine IL-10).¹²⁹

Corrections in the appearance of photoaging can be seen in Figure 23.9. After application of vitamin C (15%) + vitamin E (1%) + ferulic acid (0.5%) once daily for four months, improvement of periorbital wrinkles and solar hyperpigmentation is clearly visible.

Conclusion

Many products in today's markets claim to “moisturize,” “protect,” and “rejuvenate” the skin. Some even contain topical antioxidants. However, few formulations actually accomplish their promises. Moisturizers usually “moisturize” for only a few hours, often leaving the skin drier than before application; they also increase the translucency of the outer layer of the skin, increasing UV penetration to deeper layers. Sunscreens do effectively “protect” the skin, thereby preventing further UV-induced photoaging; however, formulations must shield from UVA as well as UVB, and must be applied copiously and frequently. Sunscreens do not protect against all UV-generated free radicals or against those initiated by environmental pollutants.

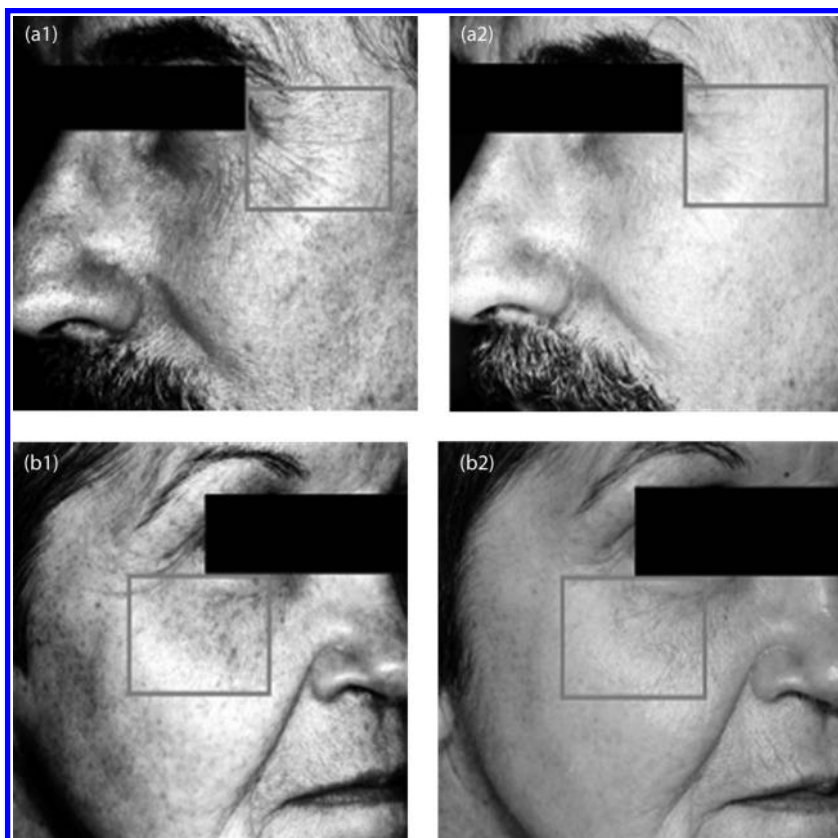

FIGURE 23.9 Antiaging with topical SkinCeuticals C E Ferulic (15% L-ascorbic acid, 1.0% d- α -tocopherol, 0.5% ferulic acid) applied once daily for four months: (a1 and a2) correction of periorbital wrinkles; (b1 and b2) correction of solar hyperpigmentation. (Reproduced with permission of SkinCeuticals.)

Topical antioxidants are truly effective not only in *protecting* the skin from UV as well as environmental pollutants, but also in *reversing* photoaging. In this chapter, the proof of that efficacy has been presented clinically, histologically, and electron microscopically, and mechanisms of action have been explained.

The advantage of topical antioxidants is that with only one application per day, they provide a reservoir of protection in the skin that cannot be washed (or perspired) away. Topical application gives far higher concentrations in the skin than can ever be attained by oral supplementation. The caveat is that each antioxidant must be formulated and tested to assure stability of each labile molecule, percutaneous absorption, and effective metabolism. The commonly available products so frequently advertised contain low concentrations or esterified forms which have little, if any, antioxidant activity. Vitamin E (d- α -tocopherol, at least 2% and optimally 5%), vitamin C (L-ascorbic acid, at least 10% and optimally 15%–20%), and L-SeMet (at least 0.02% and optimally 0.05%) meet all criteria and are indeed effective in preventing as well as reversing unattractive photoaging.

REFERENCES

1. Runger TM. Ultraviolet light. In: Bologna JL, Forizzo JL, Schaffer JV et al. eds. *Dermatology*, 3rd edn. New York: Mosby; 2012, pp.1455–65.
2. Hacham H, Freeman SE, Gange RW, Maytum DJ, Sutherland JC, Sutherland BM. Do pyrimidine dimer yields correlate with erythema induction in human skin irradiated *in situ* with ultraviolet light (275–365 nm)? *Photochem Photobiol* 1991;53:559–63.

3. Eller MS. Repair of DNA photodamage in human skin. In: Gilchrest BA, ed. *Photodamage*. Cambridge, MA: Blackwell Science; 1995, pp.26–50.
4. Fisher GJ, Kang S, Varani J et al. Mechanisms of photoaging and chronological skin aging. *Arch Dermatol* 2002;138:1462–70.
5. Senftleben U, Karin M. The I κ B/NF- κ B pathway. *Crit Care Med* 2002;30(1 suppl): S18–26.
6. Kelfkens G, de Gruijl FR, van der Leun JC. Tumorigenesis by short-wave ultraviolet A: Papillomas versus squamous cell carcinomas. *Carcinogen* 1991;12:1377–82.
7. Garssen J, van Loveren H. Effects of ultraviolet exposure on the immune system. *Crit Rev Immun* 2001;21:359–97.
8. Kochevar IE. Molecular and cellular effects of UV radiation relevant to chronic photodamages. In: Gilchrest BA, ed. *Photodamage*. Cambridge, MA: Blackwell Science; 1995, pp.51–67.
9. Ministry of the Environment. Polyaromatic hydrocarbons (PAH). Part 1: Hazard identification and dose-response assessment. In: *Scientific Criteria Document for Multimedia Standards Development*. Ontario: Ministry of the Environment; 1997.
10. Erbagci Z, Erkilic S. Can smoking and/or occupational UV exposure have any role in the development of the morpheiform basal cell carcinoma? A critical role for peritumoral mast cells. *Int J Dermatol* 2002;41:275–8.
11. Aubry F, MacGibbon B. Risk factors of squamous cell carcinoma of the skin. A case-control study in the Montreal region. *Cancer* 1985;15:907–11.
12. King GN, Healy CM, Glover MT et al. Increased prevalence of dysplastic and malignant lip lesions in renal-transplant recipients. *N Engl J Med* 1995;20:1052–7.
13. Burke KE, Wei H. Synergistic damage by UVA radiation and pollutants. *Toxicol Indust Health* 2009;64:1–6.
14. Saladi R, Austin L, Gao D et al. The combination of benzo[a]pyrene and ultraviolet A causes an *in vivo* time-related accumulation of DNA damage in mouse skin. *Photochem Photobiol* 2003;77:413–9.
15. Wang Y, Saladi R, Wei H. Synergistic carcinogenesis of chemical carcinogens and long wave-length UVA radiation. *Trends Photochem Photobiol* 2003;10:31–45.
16. Liu Z, Lu Y, Rosenstein B, Lebwohl M, Wei H. Benzo[a]pyrene enhances the formation of 8-hydroxy-2'-deoxyguanosine by ultraviolet A radiation in calf thymus DNA and human epidermoid carcinoma cells. *Biochemistry* 1998;37:10307–12.
17. Shyong EQ, Lu Y, Goldstein A, Lebwohl M, Wei H. Synergistic enhancement of H₂O₂ production in human epidermoid carcinoma cells by benzo[a]pyrene and ultraviolet A radiation. *Toxicol Appl Pharmacol* 2003;188:104–9.
18. Liang Z, Lippman SM, Kawabe A, Shimada Y, Xu XC. Identification of benzo[a]pyrene diol epoxide-binding DNA fragments using DNA immunoprecipitation technique. *Cancer Res* 2003;63:1470–4.
19. De Gruijl FR. Photocarcinogenesis: UVA vs UVB. *Methods Enzymol* 2000;319:359–66.
20. Wulf HC, Stender IM, Lock-Andersen J. Sunscreens used at the beach do not protect against erythema: A new definition of SPF is proposed. *Photodermatol Photoimmunol Photomed* 1997;13:129–32.
21. Haywood R, Wardman P, Sanders R, Linge C. Sunscreens inadequately protect against ultraviolet A-induced free radicals in skin: Implications for skin aging and melanoma. *J Invest Dermatol* 2003;121:862–8.
22. Pinnell SR, Yang HS, Omar M, Montiero-Riviere N, DeBuys HV, Walker LC. Topical L-ascorbic acid: Percutaneous absorption studies. *Dermatol Surg* 2001;27:137–42.
23. Burke KE, Clive J, Combs CF Jr., Commisso J, Kenck NK et al. The effects of topical and oral vitamin E on pigmentation and skin cancer induced by ultraviolet irradiation in Skh:2 hairless mice. *Nutr Cancer* 2000;38:87–97.
24. Burke KE, Combs GR, Gross EG et al. The effects of topical and oral L-selenomethionine on pigmentation and skin cancer induced by ultraviolet irradiation. *Nutr Cancer* 1992;17:123–37.
25. Burke KE. Oral and topical L-selenomethionine protection from ultraviolet-induced sunburn, tanning and skin cancer. *J Orthomolecular Medicine* 1992;7:83–94.
26. Burke KE, Clive J, Combs GF et al. Effects of topical L-selenomethionine with topical and oral vitamin E on pigmentation and skin cancer induced by ultraviolet irradiation in Skh:2 hairless mice. *J Am Acad Dermatol* 2003;49:458–72.
27. Razman MP. The importance of selenium to human health. *Lancet* 2000;356:233–41.
28. Roman M, Jitaru P, Barbante C. Selenium biochemistry and its role for human health. *Metallomics* 2014;6:25–54.

29. Spallholz JE, Boylan LM, Larsen HS. Advances in understanding selenium's role in the immune system. *Ann NY Acad Sci* 1990;587:123–39.
30. McKenzie RC, Rafferty TS, Beckett GJ. Selenium: An essential element for immune function. *Immunol Today* 1998;19:342–5.
31. Combs GF Jr, Lu J. Selenium as a cancer preventive agent. In: Hatfield DL, ed. *Selenium: Its Molecular Biology and Role in Human Health*. Dordrecht: Kluwer Academic Publishers; 2001, pp.205–18.
32. Whanger PD. Selenium and its relationship to cancer: An update. *Br J Nutr* 2004;91:11–28.
33. Chen YC, Prabhu KS, Mastro AM. Is selenium a potential treatment for cancer metastases? *Nutrients* 2013;5:1149–68.
34. Schrauzer GN, White DA, Schneier CJ. Cancer mortality correlation studies. III. Statistical associations with dietary selenium intakes. *Bioinorg Chem* 1977;7:23–34.
35. Shamberger RJ, Willis CE. Selenium distribution and human cancer mortality. *Crit Res Clin Lab Sci* 1971;2:211–21.
36. Combs GF Jr. Selenium. In: Micozzi MS, Moon TE, eds. *Nutrition and Cancer Prevention*. New York: Dekker; 1989, pp.389–420.
37. Combs GF Jr., Gray WP. Chemopreventive agents: Selenium. *Pharmacol Ther* 1998;79:179–92.
38. Broghamer WI, McConnell KP, Blotcky AL. Relationship between serum selenium levels and patients with carcinoma. *Cancer* 1976;37:1384–8.
39. McConnell KT, Jager RM, Bland KL, Blotcky AJ. The relationship of dietary selenium and breast cancer. *J Surg Oncol* 1980;15:67–70.
40. Reinhold U, Biltz H, Bayer W, Schmidt KH. Serum selenium levels in patients with malignant melanoma. *Acta Derm Venerol (Stockh.)* 1989;69:132–6.
41. Cassidy PB, Fain HD, Cassidy JP Jr et al. Selenium for the prevention of cutaneous melanoma. *Nutrients* 2013;5:725–49.
42. Clark LC, Graham GE, Crouse RG, Grimson R, Hulka B, Shy CM. Plasma selenium and skin neoplasms: A case control study. *Nutr Cancer* 1989;6:13–21.
43. Clark LC, Combs GF, Turnbull BW et al. Effects of selenium supplementation for cancer prevention in patients with carcinoma of the skin. A randomized controlled trial. *JAMA* 1996;276:1957–63.
44. Overvad K, Thorling EB, Bjerring P, Ebbesen P. Selenium inhibits UV-light induced skin carcinogenesis in hairless mice. *Cancer Lett* 1985;27:163–70.
45. Faergemann J, Fredriksson T. Tinea versicolor: Some new aspects on etiology, pathogenesis and treatment. *Int J Dermatol* 1982;1:8–11.
46. Bereston ES. Use of selenium sulfide shampoo in seborrheic dermatitis. *J Am Med Assoc* 1954;157:1246–7.
47. Cummins LM, Kimuka ET. Safety evaluation of selenium sulfide antidandruff shampoos. *Toxicol Appl Pharmacol* 1971;20:89–96.
48. Lin CH, Fang CL, Al-Suwayeh SA, Yang SY, Fang JY. *In vitro* and *in vivo* percutaneous absorption of seleno-L-methionine, an antioxidant agent and other selenium species. *Acta Pharmacol Sin* 2011;32:1181–90.
49. Schallreuter KU, Pittelkow MR, Wood JM. Free radical reduction by thioredoxin reductase at the surface of normal and vitiliginous human keratinocytes. *J Invest Dermatol* 1986;87:728–32.
50. Schallreuter KU, Hordinsky MK, Wood JM. Thioredoxin reductase. Role in the radical reduction in different hypopigmentation disorders. *Arch Dermatol* 1987;123:615–9.
51. Steinbrenner H, Sies H. Protection against reactive oxygen species by selenoproteins. *Biochimica et Biophysica Acta* 2009;1790:1478–85.
52. Burke KE, Bedford RG, Combs GF Jr et al. The effect of topical L-selenomethionine on minimal erythema dose of ultraviolet irradiation in humans. *Photodermatol Photoimmunol Photomed* 1992;9:52–7.
53. Burke KE. *Method for the Prevention and Reversal of the Extrinsic Aging of the Skin by Transdermal Application of Selenoamino Acids and Compositions Therefore*. US Patent 5,330,757, July 19, 1994.
54. Evans HM, Bishop KS. On the existence of a hitherto unrecognized dietary factor essential for reproduction. *Science* 1922;56:650–1.
55. Dam H. Influence of antioxidants and redox substances on signs of vitamin E deficiency. *Pharmacol Rev* 1957;9:1–16.
56. Wolf G. The discovery of the antioxidant functions of vitamin E: The contribution of Henry A. Mattill. *J Nutr* 2005;135:363–6.

57. Machlin LJ. *Vitamin E*. New York: Marcel Dekker; 1987.
58. Serbinova E, Kagan V, Han D, Packer L. Free radical recycling and intramembrane mobility in the anti-oxidant properties of alpha-tocopherol and alpha-tocotrienol. *Free Radic Bio Med* 1991;10:263–75.
59. Taber MG, Atkinson A. Vitamin E, antioxidant and nothing more. *Free Radic Bio Med* 2007;43:4–15.
60. Epstein HA. A second look at vitamin E. *Cosmetic Science* 2013;11:247–9.
61. Rimbach G, Moehring J, Huebbe P, Lodge JK. Gene regulatory activity of α -tocopherol. *Molecules* 2010;15:1746–61.
62. Müller L, Theile K, Böhm V. *In vitro* antioxidant activity of tocopherols and tocotrienols and comparison of vitamin E concentration and lipophilic antioxidant capacity in human plasma. *Mol Nutr Food Res* 2010;54:731–42.
63. Longnecker MP, Martin-Moreno JM, Knekt P et al. Serum alpha-tocopherol concentration in relation to subsequent colorectal cancer: Pooled data from five cohorts. *J Natl Cancer Inst* 1992;84:430–5.
64. Gunawardena K, Murray DK, Meikle AW. Vitamin E and other antioxidants inhibit human prostate cancer cells through apoptosis. *Prostate* 2000;44:287–95.
65. Fleshner N, Fair WR, Huryk R, Heston WD. Vitamin E inhibits the high-fat diet promoted growth of established human prostate LNCaP tumors in nude mice. *J Urol* 1999;161:1651–4.
66. Venkateswaran V, Fleshner NE, Klotz LH. Modulation of cell proliferation and cell cycle regulators by vitamin E in human prostate carcinoma cell lines. *J Urol* 2002;168:1578–82.
67. Miller ER 3rd, Pastor-Barriuso R, Dalal D, Riemersma RA, Appel LJ, Guallar E. Meta-analysis: High-dosage vitamin E supplementation may increase all-cause mortality. *Ann Intern Med* 2005;142:37–46.
68. Chen CS, Wells PG. Enhanced tumorigenesis in p53 knockout mice exposed in utero to high-dose vitamin E. *Carcinogenesis* 2006;27:1358–68.
69. Hercberg S, Ezzedine K, Guinot C et al. Antioxidant supplementation increases the risk of skin cancers in women but not in men. *J Nutr* 2007;137:2098–105.
70. Klein EA, Thompson IM Jr, Tangen CM et al. Vitamin E and the risk of prostate cancer: The selenium and vitamin E Cancer Prevention Trial (SELECT). *JAMA* 2011;306:1549–1556.
71. Cardenas E, Ghosh R. Vitamin E: A dark horse at the crossroad of cancer management. *Biochem Pharmacol* 2013;86:845–52.
72. Azzi A, Breyer I, Feher M et al. Specific cellular responses to alpha-tocopherol. *J Nutr* 2000;131 (Suppl):369–75.
73. Traber MG, Kayden HJ. Preferential incorporation of alpha-tocopherol vs gamma-tocopherol in human lipoproteins. *Am J Clin Nutr* 1989;49:517–26.
74. Traber MG, Kayden HJ. Alpha-tocopherol as compared with gamma tocopherol is preferentially secreted in human lipoproteins. *Ann NY Acad Sci* 1989;570:95–108.
75. Kayden HJ, Traber MG. Absorption, lipoprotein transport, and regulation of plasma concentrations of vitamin E in humans. *J Lipid Res* 1993;34:343–58.
76. Mustachich DJ, Shields J, Horton RA, Brown MK, Reed DJ. Biliary secretion of alpha-tocopherol and the role of the mdr2 P-glycoprotein in rats and mice. *Arch Biochem Biophys* 1998;350:183–92.
77. Potokar M, Holtmann W, Werner-Busse A. Effectiveness of vitamin E protecting against UV light—Comparative testing of the natural tocopherols on the skin of the hairless mouse. *Fat Sci Technol* 1990;92:406–10.
78. Gensler HL, Aickin M, Peng YM, Xu M. Importance of the form of topical vitamin E for prevention of photocarcinogenesis. *Nutr Cancer* 1996;26:183–91.
79. Beijersbergen van Hanegouwne GMJ, Junginger HE, de Vries H. Hydrolysis of RRR-alpha-tocopheryl acetate (vitamin E acetate) in the skin and its UV protecting activity (an *in vivo* study with the rat). *J Photochem Photobiol B: Biology* 1995;29:45–51.
80. Hart M. Vitamin E: A contact sensitizer. *The Schoch Lett* 1990;40:48.
81. de Groot AC, Berretty PJ, van Ginkel CJ, den Hengst CW, van Ulsen J, Weyland JW. Allergic contact dermatitis from tocopheryl acetate in cosmetic creams. *Contact Dermatitis* 1991;25:302–4.
82. Perrenoud D, Homberger HP, Auderset PC et al. An epidemic outbreak of papular and follicular contact dermatitis to tocopheryl linoleate in cosmetics. *Swiss Contact Dermatitis Res Group Dermatol* 1994;189:225–33.
83. Saperstein H, Rapaport M, Rietschel RL. Topical vitamin E as a cause of erythema multiforme-like eruption. *Arch Dermatol* 1984;120:905–8.

84. Podda M, Weber C, Traber MG, Packer L. Simultaneous determination of tissue tocopherols, tocotrienols, ubiquinols, and ubiquinones. *J Lipid Res* 1996;37:893–901.
85. Thiele JJ. Oxidative targets in the stratum corneum: A new basis for antioxidative strategies. *Skin Pharmacol Appl Skin Physiol* 2001;14:87–91.
86. Shindo Y, Wit E, Han D, Packer L. Dose-response effects of acute ultraviolet irradiation on antioxidants and molecular markers of oxidation in murine epidermis and dermis. *J Invest Dermatol* 1994;23:470–5.
87. Valacchi G, Weber SU, Luu C, Cross CE, Packer L. Ozone potentiates vitamin E depletion by ultraviolet radiation in the murine stratum corneum. *FEBS Lett* 2000;466:165–8.
88. Möller H, Potokar M, Wallat S. Vitamin E als Kosmetischer Wirkstoff. *Parfüm Kosmet* 1987;68:688–708.
89. Potapenko A, Abijev G, Pistosov M et al. PUVA-induced erythema and changes in mechano-electrical properties of skin inhibition by tocopherols. *Arch Dermatol Res* 1984;276:12–6.
90. Moeller H, Ansmann A, Wallat S. The effects of vitamin E on the skin in topical applications. *Fett-Wissenschaft Technol* 1989;8:295–315.
91. Trevithick J, Xiong H, Lee S et al. Topical tocopherol acetate reduces post-UVB, sunburn-associated erythema, edema and skin sensitivity in hairless mice. *Arch Biochem Biophys* 1992;296:575–82.
92. Record IR, Dreosti IE, Konstantinopoulos M, Buckley RA. The influence of topical and systemic vitamin E on ultraviolet light-induced skin damage in hairless mice. *Nutr Cancer* 1991;16:219–25.
93. Marenus K, Muizzuddin N, Kasman K et al. The use of antioxidants in providing protection from chronic suberythematous UV-B exposure. *16th IFSCC Conference*. 1990;1:24–34.
94. Berton TR, Conti CJ, Mitchell DL, Aldaz CM, Lubet RA, Fischer SM. The effect of vitamin E acetate on ultraviolet-induced mouse skin carcinogenesis. *Mol Carcinog* 1998;23:175–84.
95. Black H, Lenger W, McCann V, Thornby J. Relation of UV dose to antioxidant modification of photocarcinogenesis. *J Am Coll Toxicol* 1983;2:201–7.
96. Bissett D, Chatterjee R, Hannon D. Protective effect of a topically applied antioxidant plus an anti-inflammatory agent against ultraviolet radiation-induced chronic skin damage in the hairless mouse. *J Soc Cosmet Chem* 1992;43:85–92.
97. Gensler H, Magdaleno M. Topical vitamin E inhibition of immunosuppression and tumorigenesis induced by ultraviolet irradiation. *Nutr Cancer* 1991;15:97–106.
98. Gerrish K, Gensler H. Prevention of photocarcinogenesis by dietary vitamin E. *Nutr Cancer* 1993;19:125–33.
99. Burke KE, Clive J, Combs GF Jr., Commisso J, Keen CL, Nakamura RN. The effects of topical and oral vitamin E on pigmentation and skin cancer induced by ultraviolet irradiation in Skh:2 hairless mice. *J Nutr Cancer* 2000;38:87–97.
100. Roshchupkin D, Pistsov MY, Potapenko AY. Inhibition of ultraviolet light-induced erythema by antioxidants. *Arch Dermatol Res* 1979;266:91–4.
101. Bissett DL, Chatterjee R, Hannon DP. Photoprotective effect of superoxide-scavenging antioxidants against ultraviolet radiation-induced chronic skin damage in the hairless mouse. *Photodermatol Photoimmunol Photomed* 1990;7:56–62.
102. Pauling L. *How to Live Longer and Feel Better*. New York: WA Freeman; 1987.
103. Darr D, Combs S, Dunston S, Manning T, Pinnell S. Topical vitamin C protects porcine skin from ultraviolet radiation-induced damage. *Br J Dermatol* 1992;127:247–53.
104. Kivirikko KI, Myllylä R. Post-translational processing of procollagens. *Ann NY Acad Sci* 1996;11:250–3.
105. Savini I, Catni V, Rossi A, Duranti G, Melino G, Avigliano L. Characterization of keratinocyte differentiation induced by ascorbic acid: Protein kinase C involvement and vitamin C homeostasis. *J Invest Dermatol* 2002;118:372–9.
106. Phillips CL, Combs SB, Pinnell SR. Effects of ascorbic acid on proliferation and collagen synthesis in relation to donor age of human dermal fibroblasts. *J Invest Derm* 1994;103:228–32.
107. Davidson JM, LuValle PA, Zoia O, Quaglino D Jr, Giro M. Ascorbate differentially regulates elastin and collagen biosynthesis in vascular smooth muscle cells and skin fibroblasts by pretranslational mechanisms. *J Biol Chem* 1997;272:345–52.
108. Humbert PG, Haftek M, Creidi P et al. Topical ascorbic acid in photoaged skin. Clinical topographical and ultrastructural evaluation: Double-blind study vs. placebo. *Experiment Dermatol* 2003;12:237–44.
109. Alster T, West TB. Effect of vitamin C on postoperative CO₂-laser resurfacing erythema. *Dermatol Surg* 1998;24:331–4.

110. Bergfeld W, Pinnell S. Topical vitamin C. Dialogues in dermatology. *Am Acad Derm* 1996;38:1.
111. Carcamo JM, Pedraza A, Borquez-Ojeda O, Golde DS. Vitamin C suppresses TNF alpha-induced NF kappa B activation by inhibiting I Kappa B alpha phosphorylation. *Biochem* 2002;41:12995–30002.
112. Maeda K, Fukuda M. Arbutin: Mechanism of its depigmenting action in human melanocyte culture. *J Pharmacol Exp Ther* 1996;276:765–9.
113. Kameyama K, Sakai C, Kondoh S et al. Inhibitory effect of magnesium L-ascorbyl-2-phosphate (VC-PMG) on melanogenesis *in vitro* and *in vivo*. *J Am Acad Dermatol* 1996;34:29–33.
114. Uchida Y, Behne M, Quiec D, Elias PM, Holleran WM. Vitamin C stimulates sphingolipid production and markers of barrier formation in submerged human keratinocyte cultures. *J Invest Dermatol* 2001;117:1307–13.
115. Chan AC. Partners in defense, vitamin E and vitamin C. *Can J Physiol Pharmacol* 1993;71:725–31.
116. Eberlein-Konig B, Placzek M, Przybilla B. Protective effect against sunburn of combined systemic ascorbic acid (vitamin C) and d- α -tocopherol (vitamin E). *J Am Acad Dermatol* 1998;38:45–8.
117. Fuchs J, Kern H. Modulation of UV-light-induced skin inflammation by d- α -tocopherol and L-ascorbic acid: A clinical study using solar simulated radiation. *Free Radic Biol Med* 1998;25:1006–12.
118. Lin JY, Selim MA, Shea CR et al. UV photoprotection by combination topical antioxidants vitamin C and E. *J Am Acad Dermatol* 2003;48:866–74.
119. Dreher F, Gabard B, Schwindt DA, Malbach HI. Topical melatonin in combination with vitamins E and C protects skin from ultraviolet-induced erythema: A human study *in vivo*. *Br J Dermatol* 1998;139:332–9.
120. Quevedo WC, Holstein TJ, Dyckman J, McDonald CI. The responses of the human epidermal melanocyte system to chronic erythemal doses of UVR in skin protected by topical applications of a combination of vitamins C and E. *Pigment Cell Res* 2000;13:190–2.
121. Burke KE, Zhou X, Wang Y et al. Protection against UVB-induced skin cancer by compositions of vitamins C + E. In preparation 2015.
122. Graf E. Antioxidant potential of ferulic acid. *Free Rad Biol Med* 1992;13:435–8.
123. Rice-Evans CA, Miller NJ, Paganga G. Structure-antioxidant activity relationships of flavonoids and phenolic acids. *Free Rad Biol Med* 1996;20:933–56.
124. Ou S, Kwok K-C. Ferulic acid: Pharmaceutical functions preparation and applications in foods. *J Sci Food Agric* 2004;84:1261–9.
125. Mathew S, Abraham TE. Ferulic acid: An antioxidant found naturally in plant cell walls and feruloyl esterases involved in its release and their applications. *Crit Rev Biotechnol* 2004;24:59–83.
126. Trombino S, Serini S, Di Nicuolo F et al. Antioxidant effect of ferulic acid in isolated membranes and intact cells: Synergistic interactions with alpha-tocopherol, beta-carotene, and ascorbic acid. *J Agric Food Chem* 2004;52:2411–20.
127. Zielinski JE, Pinnell SR. *Stabilized ascorbic acid compositions and methods thereof*. US Patent 34405.2, 2004.
128. Lin FH, Lin JY, Gupta RD et al. Ferulic acid stabilizes a solution of vitamins C and E and doubles its photoprotection of skin. *J Invest Dermatol* 2005;125:826–32.
129. Murray JC, Burch JA, Streilein RD, Iannacchione MA, Hall RP, Pinnell SR. A topical antioxidant solution containing vitamins C and E stabilized by ferulic acid provides protection for human skin against damage caused by ultraviolet irradiation. *J Am Acad Dermatol* 2008;59:418–25.

The Use of Cosmeceuticals in Rosacea

Ashley Clark, Whitney A. Fisk, Hadar A. Lev-Tov, and Raja K. Sivamani

Introduction

Numerous cosmeceutical and botanical therapies are increasingly popular treatments available for rosacea. The products may contain a variety of substances including vitamins, plant extracts, phytochemicals, herbal formulations, or sulfur containing products. Some have been tested in randomized controlled trials and proven beneficial, while others tested in single group efficacy trials or hypothesized efficacy based on proposed anti-inflammatory properties have shown promising results.

Cosmeceutical products are popular among those who suffer from rosacea because they are presumed to be safer, easily obtained over the counter, and less expensive in comparison to prescribed medications. Additionally, patients who cannot tolerate the side effects of standard topical or systemic medications may be more likely to use cosmeceuticals.

One study found that 22% of patients with rosacea utilized alternative medicine, such as botanical therapies.¹ Interestingly, none of the surveyed subjects were aware of any potential adverse effects associated with these therapies and over half stated that they would not spontaneously discuss their use of complementary therapies with their dermatologist. Given the increasing popularity of these therapies, health professionals should be aware of their benefits, risks, and clinical utility. This chapter describes the available clinical research that evaluates cosmeceutical and botanical therapies for rosacea. Botanical therapies' effects on all primary symptoms of rosacea are discussed, with special emphasis on improvement in facial erythema, as current treatments for erythema are limited.

Rosacea is a common chronic inflammatory skin disease presenting with various combinations of features of the cutaneous disorder. Primary morphological characteristics include persistent to transient facial erythema, flushing, papules and pustules, and telangiectasias. Secondary features can occur alone or with one or more of the primary features; they include burning, plaques, dry appearance, edema, ocular manifestations, peripheral locations, and phymatous changes.² The disease almost exclusively affects the central areas of the face (cheek, nose, chin, and central forehead).² People with lighter skin pigmentation are more commonly affected and prevalence increases with age.² Although the disorder is benign, the symptoms can be distressing, uncomfortable, and frequently resistant to treatment.² Due to the varied manifestations of rosacea, the National Rosacea Society has defined four subtypes of rosacea: erythematotelangiectatic, papulopustular, ocular, and phymatous subtypes.²

Pathogenesis

The pathogenesis of rosacea is complex and not fully delineated. Several key contributing factors include immune dysregulation, compromised epidermal barrier function, and vascular hyper-reactivity. Documented vascular abnormalities include increased expression of angiogenic mediators³ and compromised vascular integrity.⁴⁻⁶ Histologically, findings include dilated blood and lymphatic vessels leading to erythema and edema; a perivascular infiltrate consisting of increased T cells, macrophages, and mast cells; and occasionally solar elastosis, and tortuous vessels.⁶ Hyperactive inflammatory responses may precipitate these abnormalities.^{7,8}

External factors that can precipitate symptoms of rosacea (mainly flushing) include sun exposure, emotional stress and ingestion of alcohol, spicy foods, and caffeine. Additionally, *Demodex folliculorum*, facial mite, may contribute to rosacea's pathogenesis, particularly in association with papulopustular lesions.⁹ These likely trigger symptoms by stimulating inflammatory cascades and production of reactive oxygen species (ROS).¹⁰ Ultraviolet (UV) radiation exposure, for example, leads to increased ROS in the skin, which elicits an immune response and increases expression of angiogenic factors.¹¹ Other known extrinsic triggers of rosacea, including emotional stress and alcohol intake, are associated with increased production of ROS and proinflammatory mediators.¹⁰

Treatments: Vitamins (Table 24.1)

Niacinamide

Niacinamide, an amide of nicotinic acid (also known as vitamin B3), is a water-soluble vitamin found most commonly in wheat, meat, and fish. Niacinamide acts as an antioxidant but also possesses biological activities, making it an important emerging cosmetic ingredient.¹² Due to the anti-inflammatory action, skin lightening properties, and decrease in sebum production, vitamin B3 may be beneficial to patients with rosacea.¹²

Rosacea patients who do not tolerate conventional therapies may benefit from botanical interventions and some studies suggest that natural therapies may be used as alternatives to conventional treatments. A prospective cohort study of 198 patients with acne vulgaris and/or rosacea analyzed the clinical use of oral pharmacologic doses of nicotinamide and zinc. Patients taking an oral supplement containing a mixture of nicotinamide, zinc, copper, and folate responded equally well to a single topical therapy as they did to multiple topical therapies.¹³ Also, adding an oral antibiotic to the nicotinamide supplement did not significantly improve treatment outcomes. Given this, the authors suggest that oral nicotinamide/zinc/copper/folate might be an alternative to oral antibiotic therapies. Furthermore, they report that 82% of participants who had previously received antibiotic therapy considered nicotinamide/zinc/copper/folate tablets to be as effective or superior to previously trialed antibiotics. Trials directly comparing nicotinamide and antibiotics are lacking.

Nicotinamide and zinc have a variety of potential mechanisms of action contributing to the outcome of the study, including: (1) an anti-inflammatory effect via inhibition of leukocyte chemotaxis, lysosomal enzyme release, lymphocytic transformation, and mast cell degranulation; (2) bacteriostatic effect against *Propionibacterium acnes*; (3) inhibition of vasoactive amines; (4) preservation of intracellular coenzyme homeostasis; and (5) decreased sebum production.¹²

Plant Extracts (Table 24.1)

Feverfew

Derived from dried chrysanthemum leaves, feverfew is a herb long used in traditional medicine to reduce fever and treat headache, arthritis, and digestive problems.¹² The plant contains potent anti-inflammatory, antioxidant, and anti-irritant properties. The volatile oils, flavonoids, and parthenolides are the main components in feverfew that act by inhibiting 5-lipoxygenase and cyclooxygenase, leading to a reduction in platelet aggregation and serotonin release.¹² Since the advent of a purified feverfew extract that removed the parthenolides, an irritant compound, the compound has been used to reduce facial redness and skin irritation. In a study conducted by Martin and associates, 1% feverfew parthenolide-free extract was used for 45 days and improved mild inflammatory acne by inhibiting the release of inflammatory markers from activated lymphocytes and reducing neutrophil chemotaxis.¹⁴ The immunomodulating properties suggest feverfew may be a useful treatment for rosacea.

TABLE 24.1

Summary of Clinical Studies Evaluating Cosmeceutical Therapies for Rosacea

Intervention	Comparison	Outcome Measure	Major Results	Limitations and Notes
Chibixiao recipe combined with minocycline and spironolactone	Control group received only minocycline and spirono-lactone	<ol style="list-style-type: none"> 1. Clinically evaluated erythema, capillary dilatation, papule and pustule count after 8-week study and 4-month follow-up 2. Serum testosterone levels 	<ol style="list-style-type: none"> 1. Treatment combination significantly more effective than control (for both ET and papular subtypes) 2. Serum testosterone levels significantly less after therapy in treatment group (same at baseline) 3. Significantly less recurrence at 4 months in treatment group 	<ol style="list-style-type: none"> 1. Also used cryotherapy for capillary dilation in both groups 2. Criteria for assessing clinical signs not described 3. Outcomes presented categorically
<i>Chrysanthellum indicum</i> 1% extract (cream)	Vehicle cream	<ol style="list-style-type: none"> 1. Severity of erythema referenced against 6 photographs 2. Surface area of erythema and rosacea 3. Overall severity scores by physician and subject 	<ol style="list-style-type: none"> 1. Significant improvement in erythema and overall rosacea severity compared to placebo and baseline 2. No significant difference in area involved between groups 	Authors suggest similar treatment efficacy as topical metronidazole in discussion
Epigallocatechin-3-gallate (EGCG) 2.5% cream	Vehicle cream	<ol style="list-style-type: none"> 1. Biopsies for immunohistochemistry (VEGF and HIF-1α—hypoxia inducible factor-1-alpha) 2. Colorimetry 3. Skin exam 	<ol style="list-style-type: none"> 1. Significant decrease in VEGF and HIF-1α expression in treated skin 2. No significant difference in vascularity in biopsy samples or colorimetric assessment of erythema 	Subjects included those with ET rosacea and those with facial erythema not due to rosacea
Kinetin lotion (Kinerase [®])	None	<ol style="list-style-type: none"> 1. Inflammatory papule count 2. Erythema and telangiectasia scored on 4-point scale 3. Overall severity on a 7-point scale 4. Overall improvement on a 6-point scale compared with baseline 	<ol style="list-style-type: none"> 1. No significant change in papule count or telangiectasia score 2. Significant decrease in erythema score 3. Product well tolerated 	Subjects also used SPF 30 and no control group to isolate this effect
Licochalcone (cream moisturizer)	None	<ol style="list-style-type: none"> 1. Four point NRS (national rosacea society) scale 2. Severity of erythema (mexameter) 3. Skin hydration (corneometer) 4. TEWL (tewameter) 	<p>Significant decrease in erythema severity, increase in skin moisture and decrease in TEWL values compared with baseline</p> <p>(Note: Unclear whether change in NRS score was significant)</p>	Patients also used moisturizer with SPF during morning and night cream with panthenol which may have contributed to efficacy

(Continued)

TABLE 24.1 (Continued)

Summary of Clinical Studies Evaluating Cosmeceutical Therapies for Rosacea

Intervention	Comparison	Outcome Measure	Major Results	Limitations and Notes
Licochalcone-A (cleanser, SPF15 day and night creams, concealer)	None	<ol style="list-style-type: none"> 1. Scale of 1–3 for erythema, burning, itching, stinging, tingling, and tightness 2. Digital photography with and without cross polarizing filter 3. QOL questionnaire converted to QOL index 	<ol style="list-style-type: none"> 1. Significant improvements in erythema scores in both rosacea and non-rosacea group 2. More significant results in non-rosacea group 3. Significant improvement in QOL index 	Overall improvement rated as 2.56 (between no and mild improvement)
Licochalcone-A combined with metronidazole	None	<ol style="list-style-type: none"> 1. Scale of 1–3 for erythema, burning, itching, stinging, tingling and tightness 2. Papule and pustule counts ($n = 8$) 	<ol style="list-style-type: none"> 1. Significant improvement in erythema, burning, stinging, itching, tightness, and tingling compared to baseline after 2 and 4 weeks 2. Significant decreases in lesion counts at 2 and 4 weeks for papules and at 4 weeks for pustules 	<ol style="list-style-type: none"> 1. Lic-A used for only second half of 4-week study 2. Authors note that this study proves that two products are compatible. LicA not studied independently.
Niacinamide-containing moisturizer (Olay Total Effects 7 Visible Anti-Aging Vitamin Complex)	Untreated forearm (forearms used to test barrier functions, not rosacea symptoms)	<ol style="list-style-type: none"> 1. Instrumental assessment of barrier function of forearm (DMSO probe) 2. Instrumental assessment of stratum corneum 3. Dermatologist evaluation of rosacea severity (4-point scale) 4. Subject self-assessment 	<ol style="list-style-type: none"> 1. Significant improvement in skin barrier function parameters 2. Erythema improved “markedly” over 4 weeks and papule/pustule counts decreased (no statistics) 3. No change in telangiectasias 	<ol style="list-style-type: none"> 1. Single Blind 2. Barrier function tested on forearm (randomization refers to which forearm was treated) 3. Did not evaluate vehicle independently for effect on TEWL
Oral Nicotinamide and Zinc (“Nicomide” 750 mg nicotinamide, 24 mg zinc, 1.5 mg copper, 500 µg folic acid)	N/A	<ol style="list-style-type: none"> 1. Self reported patient global evaluation (scale 1–5) 2. Self reported reduction in inflammatory lesions (IL) 3. Patient satisfaction 	<ol style="list-style-type: none"> 1. 75% (of rosacea subgroup) reported appearance was moderately or much better after 8 weeks 2. Significant reduction in IL (in rosacea subgroup) after 8 weeks of treatment (slower onset of action compared with acne patients) 3. Participants taking an oral antibiotic and Nicomide did not improve significantly more than those taking Nicomide as their only oral medication 	<ol style="list-style-type: none"> 1. Self reported outcomes by questionnaire (no objective evaluation by independent observer)* 2. Did not control for other treatments but did ask participants to report these

(Continued)

TABLE 24.1 (Continued)

Summary of Clinical Studies Evaluating Cosmeceutical Therapies for Rosacea

Intervention	Comparison	Outcome Measure	Major Results	Limitations and Notes
<i>Quassia amara</i> , 4% extract (gel)	None	<ol style="list-style-type: none"> 1. Papule and pustule count 2. Severity of flushing (0–3) 3. Severity of telangiectasia (0–3) 4. Overall improvement 	<ol style="list-style-type: none"> 1. Significant decrease in flushing score, papule and pustule score, erythema score and telangiectasia score 2. Complete resolution of pustules 	Authors note: patients with severe rosacea were most improved
Silymarin and methylsulfon-lmethane (cream)	Placebo (vehicle cream)	<ol style="list-style-type: none"> 1. Clinical evaluation for erythema, itching, stinging, burning and papules on 5-point scale 2. Corneometer for skin hydration 3. Erythema index with mexameter 	<ol style="list-style-type: none"> 1. Significant reductions in papule count, erythema, stinging, and itch scores compared to placebo 2. Significant decrease in erythema index compared to placebo and baseline 3. Significant improvement in corenometry in both groups 	Improvement in corneometry may be due to moisturizing effects and is present in both groups
Silymarin cream (Rosacure®: Synchrose Intensive®)	None	Clinical evaluation of erythema on each facial area (nose, cheek, forehead, chin) on a 6 point scale and telangiectasia on 5 point scale	Statistically significant improvement in erythema compared to baseline but not in telangiectasia	<ol style="list-style-type: none"> 1. Participants also given sunscreen which may have contributed to efficacy 2. Cream also contains tocopheryl acetate, hyaluronic acid, and acetyl glucosamine
Abstracts				
Palmitoyl tripeptide-8, epurea extract, bisabolol, caffeine and zinc gluconate (lotion)	None	<ol style="list-style-type: none"> 1. Clinical evaluation of redness, flushing, overall appearance, and rosacea severity using a 5-point scale 2. Instrumental assessment of TEWL, hydration, and skin redness 	<ol style="list-style-type: none"> 1. Significant improvements in redness, flushing, overall appearance, rosacea severity, and lesion count compared to baseline 2. TEWL measurements steady throughout the study 	Sponsored by L’Oreal Research and Innovation Incomplete information in oral presentation
Flavanoid creams (contents not specified in abstract)	None	<ol style="list-style-type: none"> 1. 4-point NRS scale 2. Tewameter measurement 3. Mexameter measurement 	<ol style="list-style-type: none"> 1. Reduction in severity of erythema 2. Reduction in average TEWL values after treatment 	Incomplete information in oral presentation

Licorice Extract

Licochalcone A, a licorice extract isolated from the root of *Glycyrrhiza inflata* plants, has been used in alternative Chinese medicine for its treatment of a variety of inflammatory conditions due to its anti-irritant and anti-inflammatory properties.¹² Multiple studies demonstrated that licorice reduced inflammation and exerts immunomodulatory effects by regulating cytokines and interferon.¹² The anti-inflammatory properties originate from licorice's ability to inhibit superoxide anion production and cyclo-oxygenase activity.¹⁵

Licochalcone A has been shown to have anti-inflammatory effects.¹⁶ The results of the high therapeutic index of the compound led the authors to believe that licochalcone A may be a promising candidate for cosmetic application. Broniarczyk-Dyla et al. investigated the efficacy of a licochalcone cream regimen and recommended its use in patients with rosacea as well as "pre-rosacea," which they define as sensitive skin with increased vascular reactivity.¹⁷ Furthermore, Weber et al. conducted an eight-week skin care regimen with licochalcone, which indicated statistically significant improvements in erythema scores in patients with mild-to-moderate erythemalangiectatic rosacea.¹⁸ The patients also reported an improved quality of life that corresponded with a reduction in redness.¹⁸

Crysanthellum indicum Extract

Crysanthellum indicum is a plant extract containing a combination of phenylpropenoic acids, flavonoids, and saponosids, and has a well documented effect on vascular wall permeability and mechanical resistance of capillaries.¹⁹ Rigopoulos and associates studied 246 patients diagnosed with moderate rosacea in a multicenter randomized, double-blind, placebo-controlled study comparing a cream containing 1% extract of *Crysanthellum indicum* vs. placebo applied twice a day over 12 weeks.¹⁹ After the 12 weeks, treatment with *Crysanthellum indicum* extract cream resulted in significant improvement in the severity of erythema and overall rosacea severity compared with the baseline and placebo.

Quassia amara

Quassia amara is a tropical plant species widely used in folk medicine for a variety of indications, including parasitic and digestive diseases.²⁰ The extract contains high levels of active phytochemicals, such as the triterpenoid quassinoids; these phytochemicals have various activities against pediculosis as well as anti-inflammatory properties.²⁰ The anti-parasitic action of quassia potentially acts on *Demodex folliculorum*, a facial mite in the hair follicle, playing a role in the onset and maintenance of rosacea. The properties of *Quassia amara* have allowed researchers to successfully use topical hydroglycolic extract of quassia on patients with rosacea.

Ferrari and Diehl conducted a 30-patient single-center, open-label study investigating the treatment of various grades of rosacea with a topical gel containing 4% *Quassia amara* extract for six weeks. At the end of therapy, overall improvement, safety, and tolerability was assessed. The treatment was extremely effective, and the patients experienced a significant reduction in flushing, papules, pustules, and telangiectasia. Improvements in global assessment of disease severity determined by the investigators also showed excellent results at the end of the treatment.²⁰ Of note, this study did not utilize a control group, and additional clinical trials involving larger groups and double-blinded, placebo controlled trials are needed.²⁰ In conclusion, topical quassia extract may be an effective tool in the management of rosacea.

Phytochemicals (Table 24.1)

Epigallocatechin-3-Gallate (EGCG)

Phytochemicals are biologically active plant-derived compounds and are thought to be responsible for the health-promoting effects of foods such as fruits, vegetables, and teas.²¹ These chemicals include

flavonoids, lignans, and catechins, among others. EGCG is a phytochemical isolated from *Camilla sinensis*, the plant from which green, white, and black teas are made. The green tea derivatives from the buds and leaves contain epicatechin, epigallocatechin, epicatechin-3-gallate, and epigallocatechin-3-gallate, which possess antioxidant, anti-inflammatory, and anticarcinogenic properties.^{22–24} The antioxidant effects presumably work by eliminating reactive oxygen species and inhibiting nitric oxide synthetase, lipoxygenase, cyclooxygenase, and lipid peroxidase. Additionally, green tea is purported to inhibit the infiltration of inflammatory cells, such as macrophages and neutrophils, and the resultant decrease of pro-inflammatory cytokines contributes to the anti-inflammatory activity. Lastly, the inhibition of carcinogen-DNA binding and subsequent tumorigenesis leads to the anticarcinogenic property.¹²

Several studies suggest that botanical therapies may be useful as preventative agents. Domingo et al. show that EGCG cream suppresses vascular endothelial growth factor (VEGF) and hypoxia inducible factor-1 α (HIF-1 α), two compounds that stimulate angiogenesis.²⁵ Based on histochemical analysis of treated skin, they suggest that the cream may prevent or slow development of telangiectasias and erythema and thus may be useful as a preventative therapy. However, chromameter measurements did not show a significant difference in the clinically observable erythema between a split-face assessment of topical EGCG and placebo. Conceivably, measurable clinical improvement may not have been evident in this trial after only six weeks of topical therapy.²⁵ Of note, this split-face study included only four participants.

Herbal Formulation (Table 24.1)

Chibixiao Recipe

One clinical trial using an herbal formulation evaluated treatment regimens combining botanical therapies with conventional treatment. Chibixiao recipe includes: loquat leaf, mulberry bark, scutellaria root, safflower, red sage root, and *Angelica dahurian* root, all of which have the function of activating blood circulation and removing stasis, thus improving microcirculation.²⁶ The addition of Chibixiao recipe (a herbal formulation) to treatment with minocycline and spironolactone significantly improved the overall appearance of erythema and papule and pustule rosacea and decreased recurrence rates at a four-month follow-up.²⁶

Sulfur

Silymarin/Methylsulfonilmethane

Silymarin is a polyphenol bioflavonoid that acts as a free-radical scavenger, and studies have proved that it possesses anti-inflammatory action by inhibiting the release of prostaglandin E2 and interleukin-1B.²⁷ Methylsulfonilmethane (MSM) has a strong photoprotective action, which can increase the survival of keratinocytes and fibroblasts after irradiation with either UVA or UVB rays. Combining silymarin/MSM has also been shown to desensitize the skin from allergens such as nickel sulfate. Both silymarin and MSM have powerful antioxidant effects and down-regulate the release of vascular endothelial growth factor from keratinocytes.²⁷ Silymarin/methylsulfonilmethane (S-MSM) is an organic sulfur-rich compound present in various foods such as fruit and vegetables, as well as in tea, coffee, beer, and cereals.²⁷ The combination of S-MSM showed a higher modulating activity on different cytokines and angiokines when compared with the single activity of each compound individually.

In a randomized, double-blind, placebo-controlled trial conducted by Berardesca et al., a combination of silymarin-MSM cream or a placebo was applied twice daily for one month. The study demonstrated the combined action of silymarin and MSM in the treatment of erythematous and telangiectatic stage of rosacea. S-MSM significantly controlled and reduced intermittent and permanent erythema and the density of the telangiectatic network.²⁷ At the same time, a reduction in the count of papules was seen in only the S-MSM treated group. Additionally, secondary symptoms of itching, stinging, and burning were reduced as well.

Sulfacetamide 10%/Sulfur 5%

Sodium sulfacetamide 10%/sulfur 5% is a supplemental option for the topical treatment of rosacea that can be used in addition to first-line therapies. The use of sulfacetamide 10%/sulfur 5% in rosacea was established in the 1950s.²⁸ Currently there are a plethora of different products available ranging from lotions, creams, cleansers, foams, and gel formulations.²⁸ Sodium sulfacetamide 10%/sulfur 5% treatment provides antifungal, antibacterial, keratolytic, and anti-inflammatory benefits.²⁹

A randomized, double-blinded study combining sodium sulfacetamide 10%/sulfur 5% with two non-PABA sunscreen agents vs. metronidazole 0.75% cream for 12 weeks showed significantly better results in the sodium sulfacetamide 10%/sulfur 5% group. There was a significantly greater improvement in the investigator's global severity rating, reduction in inflammatory lesions, and improved erythema with sodium sulfacetamide 10%/sulfur 5% cream compared with metronidazole.²⁸ Furthermore, a prospective case series from Trumbore and associates evaluated the efficacy and safety of a sodium sulfacetamide 10%/sulfur 5% emollient (SSSE) foam for the treatment of papulopustular rosacea in eight patients. Treatment with SSSE foam resulted in statistically significant improvements in clinician rated rosacea clinical scorecard assessment compared with the baseline for the overall evaluation of rosacea severity as well as global papulopustular rosacea, erythema, papules and pustules and telangiectasia. Additionally, the patient reported quality of life measures showed significant improvements following 28 and 56 days of treatment. The results of the study suggest SSSE foam may be an acceptable treatment option for papulopustular rosacea.²⁹

Efficacy of Botanicals for Specific Rosacea Symptoms

Rosacea is a heterogeneous disease characterized by several primary symptoms: flushing, erythema, telangiectasias, papules, and pustules.² The reviewed studies include subjects with the ET and PP subtypes and many evaluated improvement in each of the primary rosacea symptoms separately (Table 24.2). Botanicals were most effective for improving facial erythema and papule/pustule counts.

TABLE 24.2

Subtypes of Rosacea with Associated Characteristics and Cosmeceutical Therapies

Subtype	Characteristics	Interventions
Papules and pustules	Inflammatory lesions	<i>Quassia amara</i> , 4% extract (gel) Silymarin extract/sodium sulfacetamide 10%/sulfur 5% Niacinamide Nicotinamide/zinc/copper/folate oral tablet Chibixiao recipe
Facial erythema	Diffuse centrofacial redness, enlarged and chronically dilated superficial cutaneous vasculature	<i>Quassia amara</i> , 4% extract (gel) Licochalcone (cream moisturizer) Silymarin extract/sodium sulfacetamide 10%/sulfur 5% Niacinamide Nicotinamide/zinc/copper/folate oral tablet <i>Crysanthellum indicum</i> extract Licochalcone moisturizer Chibixiao recipe Kinetin cream Flavanoid creams
Telangiectasias	Fixed vascular changes	<i>Quassia amara</i> , 4% extract (gel) EGCG 2.5% (cream)
Flushing	Acute or subacute vasodilation of superficial cutaneous vasculature	Palmitoyl tripeptide-8, epurea extract, bisabolol, caffeine and zinc gluconate (lotion)

Source: Adapted from Wilkin J et al. *J Am Acad Dermatol* 2002;46:584–7; Del Rosso JQ, Baldwin H, Webster G. *J Drugs Dermatol* 2008;7:531–3.

*Quassia amara*²⁰ extract, lichochoalcone moisturizer,^{17,18} silymarin extract,²⁷ *Crysanthellum indicum* extract, kinetin cream, nicotinamide/zinc/copper/folate oral tablet, and Chibixiao recipe improved facial erythema. *Quassia amara* extract,²⁰ niacinamide,³⁰ silymarin,²⁷ and oral nicotinamide/zinc/copper/folate supplementation¹³ improved papule and pustule counts. *Quassia amara* extract reportedly led to the complete resolution of pustules in participants; although, of note, this study did not utilize a control group.²⁰

Only *Quassia amara* extract improved the appearance of telangiectasias²⁰; several other botanicals were ineffective, including silymarin³¹ and niacinamide cream.³¹ Topical EGCG cream did not clinically improve the appearance of telangiectasias; however, based on histochemical analysis of treated skin, Domingo et al. suggest that the cream may be effective in slowing telangiectasia formation.²⁵ Measurable clinical improvement may not have been evident in this trial after only six weeks of topical therapy.²⁵

Adverse Reactions

Mild adverse reactions, such as transient redness, burning, or pruritus, were noted in some of the studies reviewed. However, patients and physicians should be aware of the potential for hypersensitivity reactions and adverse effects from botanical products. Of note, several botanicals commonly used for rosacea have not been studied clinically.¹² Niacinamide, the amide of niacin (also known as vitamin B3) does not have the same vasodilatory effects of niacin. Therefore, niacinamide does not cause flushing, itching, or burning.¹²

Feverfew extract, for example, can elicit a hypersensitivity reaction, despite its antioxidant and anti-inflammatory properties.³² Additionally, parthenolide, a component of feverfew, if not removed causes irritation. Studies using *Quassia amara* extract have yet to demonstrate adverse reactions.

Users of *Crysanthellum indicum* reported mild adverse reactions, although they did not differ between the *C. indicum* extract treatment group and the placebo group. More than half of the patients who experienced adverse events defined their skin as sensitive on inclusion.¹⁹ The safety and tolerability of sodium sulfacetamide 10%/sulfur 5% are good, with rare reports of skin irritation, dryness, or redness.²⁸

Also, most oral botanicals are classified as dietary supplements and thus are not regulated by the FDA. Therefore, manufacturers do not have to prove the safety of botanical products before distribution; hence, adverse effects are less predictable.

Conclusions

Botanical and cosmeceutical therapies are increasingly popular for dermatologic conditions including rosacea. Based on the limited available clinical data, several plant extracts, vitamins, phytochemicals, herbal formulations, and sulfur compounds are promising therapies for rosacea. Overall, botanicals seem to be most effective for reducing facial erythema and reducing papule/pustule counts. There is significant evidence from preclinical and clinical studies that botanical agents, including those used for the treatment of rosacea, are photoprotective and thus may reduce flares triggered by UV exposure.^{33–41} Several botanicals interfere with angiogenesis at a molecular level, although only one has been shown to clinically improve telangiectasias, and this finding has yet to be duplicated.

Overall, the clinical data suggests that botanicals and cosmeceuticals may be used as a monotherapy or adjuvant therapy and may be as effective as conventional therapies for some patients. Preventative treatment strategies may be appropriate for patients with early symptoms or a strong likelihood of developing symptoms. Using botanical and conventional therapies simultaneously may be beneficial, as long as their pharmacological effects do not interfere with the effects of conventional therapies.

Botanicals may be of particular use in patients sensitive to conventional therapies. Patients with rosacea are notoriously sensitive to medications and topical products. Therefore, even botanical therapies should be trialed and then integrated into skin care regimens slowly. All patients should be encouraged to use sunscreen and avoid common triggers. Further clinical research into the effectiveness of cosmeceuticals in the treatment of rosacea is acutely warranted, especially to compare botanical therapies

with conventional treatments. Future studies should use validated grading systems and control for inter-rater variability, and should supplement these with objective measurements of rosacea severity whenever possible.

REFERENCES

1. McAleer MA, Powell FC. Complementary and alternative medicine usage in rosacea. *Br J Dermatol* 2008;158:1139–41.
2. Wilkin J, Dahl M, Detmar M et al. Standard grading system for rosacea: Report of the National Rosacea Society Expert Committee on the classification and staging of rosacea. *J Am Acad Dermatol* 2004;50:907–12.
3. Gomaa AH, Yaar M, Eyada MM, Bhawan J. Lymphangiogenesis and angiogenesis in non-phymatous rosacea. *J Cutan Pathol* 2007;34:748–53.
4. Neumann E, Frithz A. Capillaropathy and capillaroneogenesis in the pathogenesis of rosacea. *Int J Dermatol* 1998;37:263–6.
5. Aroni K, Tsagroni E, Kavantzias N, Patsouris E, Ioannidis E. A study of the pathogenesis of rosacea: How angiogenesis and mast cells may participate in a complex multifactorial process. *Arch Dermatol Res* 2008;300:125–31.
6. Steinhoff M, Schaubert J, Leyden JJ. New insights into rosacea pathophysiology: A review of recent findings. *J Am Acad Dermatol* 2013;69:S15–26.
7. Jones D. Reactive oxygen species and rosacea. *Cutis* 2004;74:17–20, 32–14.
8. Bakar O, Demircay Z, Yuksel M, Haklar G, Sanisoglu Y. The effect of azithromycin on reactive oxygen species in rosacea. *Clin Exp Dermatol* 2007;32:197–200.
9. Georgala S, Katoulis AC, Kylafis GD et al. Increased density of Demodex folliculorum and evidence of delayed hypersensitivity reaction in subjects with papulopustular rosacea. *J Eur Acad Dermatol Venereol* 2001;15:441–4.
10. Del Rosso JQ. Advances in understanding and managing rosacea: Part 1: Connecting the dots between pathophysiological mechanisms and common clinical features of rosacea with emphasis on vascular changes and facial erythema. *J Clin Aesthet Dermatol* 2012;5:16–25.
11. Murphy G. Ultraviolet light and rosacea. *Cutis* 2004;74:13–16, 32–14.
12. Emer J, Waldorf H, Berson D. Botanicals and anti-inflammatories: Natural ingredients for rosacea. *Semin Cutan Med Surg* 2011;30:148–55.
13. Niren NM, Torok HM. The Nicomide Improvement in Clinical Outcomes Study (NICOS): Results of an 8-week trial. *Cutis* 2006;77:17–28.
14. Martin K, Sur R, Liebel F et al. Parthenolide-depleted Feverfew (*Tanacetum parthenium*) protects skin from UV irradiation and external aggression. *Arch Dermatol Res* 2008;300:69–80.
15. Kolbe L, Immeyer J, Batzer J et al. Anti-inflammatory efficacy of Licochalcone A: Correlation of clinical potency and *in vitro* effects. *Arch Dermatol Res* 2006;298:23–30.
16. Wu J. Treatment of rosacea with herbal ingredients. *J Drugs Dermatol* 2006;5:29–32.
17. Broniarczyk-Dyla G, Prusinska-Bratos M, Kmiec ML. Assessment of the influence of licochalcone on selected functional skin parameters in patients with impaired vasomotor disorders and rosacea. *Post Dermatol Alergol* 2011;28:241–54.
18. Weber TM, Ceilley RI, Buerger A et al. Skin tolerance, efficacy, and quality of life of patients with red facial skin using a skin care regimen containing Licochalcone A. *J Cosmet Dermatol* 2006;5:227–32.
19. Rigopoulos D, Kalogeromitros D, Gregoriou S et al. Randomized placebo-controlled trial of a flavonoid-rich plant extract-based cream in the treatment of rosacea. *J Eur Acad Dermatol Venereol* 2005;19:564–8.
20. Ferrari A, Diehl C. Evaluation of the efficacy and tolerance of a topical gel with 4% quassia extract in the treatment of rosacea. *J Clin Pharmacol* 2012;52:84–8.
21. Arts IC, Hollman PC. Polyphenols and disease risk in epidemiologic studies. *Am J Clin Nutr* 2005;81:317s–25s.
22. Chiu AE, Chan JL, Kern DG et al. Double-blinded, placebo-controlled trial of green tea extracts in the clinical and histologic appearance of photoaging skin. *Dermatol Surg* 2005;31:855–60; discussion 860.
23. Berson DS. Natural antioxidants. *J Drugs Dermatol* 2008;7:s7–12.

24. Camouse MM, Hanneman KK, Conrad EP, Baron ED. Protective effects of tea polyphenols and caffeine. *Expert Rev Anticancer Ther* 2005;5:1061–8.
25. Domingo DS, Camouse MM, Hsia AH et al. Anti-angiogenic effects of epigallocatechin-3-gallate in human skin. *Int J Clin Exp Pathol* 2010;3:705–9.
26. Yu TG, Zheng YZ, Zhu JT, Guo W. Effect of treatment of rosacea in females by Chibixiao Recipe in combination with minocycline and spironolactone. *Chin J Integr Med* 2006;12:277–80.
27. Berardesca E, Cameli N, Cavallotti C et al. Combined effects of silymarin and methylsulfonylmethane in the management of rosacea: Clinical and instrumental evaluation. *J Cosmet Dermatol* 2008;7:8–14.
28. Bikowski JB, Goldman MP. Rosacea: Where are we now? *J Drugs Dermatol* 2004;3:251–61.
29. Trumbore MW, Goldstein JA, Gurge RM. Treatment of papulopustular rosacea with sodium sulfacetamide 10%/sulfur 5% emollient foam. *J Drugs Dermatol* 2009;8:299–304.
30. Draelos ZD, Ertel K, Berge C. Niacinamide-containing facial moisturizer improves skin barrier and benefits subjects with rosacea. *Cutis* 2005;76:135–41.
31. Nield GL, Ippersiel R. Open evaluation of silymarin cream in the management of facial redness associated with rosacea. *Cosmet Dermatol* 2002;15:15–7.
32. Sharma VK, Sethuraman G. Parthenium dermatitis. *Dermatitis* 2007;18:183–90.
33. Stahl W, Sies H. Carotenoids and flavonoids contribute to nutritional protection against skin damage from sunlight. *Mol Biotechnol* 2007;37:26–30.
34. Katiyar SK. Skin photoprotection by green tea: Antioxidant and immunomodulatory effects. *Curr Drug Targets Immune Endocr Metabol Disord* 2003;3:234–42.
35. Katiyar S, Elmets CA, Katiyar SK. Green tea and skin cancer: Photoimmunology, angiogenesis and DNA repair. *J Nutr Biochem* 2007;18:287–96.
36. Katiyar SK, Elmets CA. Green tea polyphenolic antioxidants and skin photoprotection (Review). *Int J Oncol* 2001;18:1307–13.
37. Katiyar SK, Korman NJ, Mukhtar H, Agarwal R. Protective effects of silymarin against photocarcinogenesis in a mouse skin model. *J Natl Cancer Inst* 1997;89:556–66.
38. Katiyar SK, Perez A, Mukhtar H. Green tea polyphenol treatment to human skin prevents formation of ultraviolet light B-induced pyrimidine dimers in DNA. *Clin Cancer Res* 2000;6:3864–9.
39. Elmets CA, Singh D, Tubesing K et al. Cutaneous photoprotection from ultraviolet injury by green tea polyphenols. *J Am Acad Dermatol* 2001;44:425–32.
40. Surjana D, Damian DL. Nicotinamide in dermatology and photoprotection. *Skinmed* 2011;9:360–5.
41. Chiu P-C, Chan C-C, Lin H-M, Chiu H-C. The clinical anti-aging effects of topical kinetin and niacinamide in Asians: A randomized, double-blind, placebo-controlled, split-face comparative trial. *J Cosmet Dermatol* 2007;6:243–9.

Cosmeceutical Treatments for Androgenetic Alopecia

Michael S. Leo, Howard I. Maibach, and Raja K. Sivamani

Pathogenesis

Androgenetic alopecia (AGA) is a genetic condition, characterized by hair loss on the temporal region and the top of the head, that can progress to complete hair loss in men and women, although predominantly in men. Androgenetic alopecia results from the miniaturization of the hair follicle and a decrease in the length of the anagen (long growth) cycle with subsequent increases in telogen (short resting) cycle.¹ The androgens testosterone and 5 α -dihydrotestosterone (DHT), as well as the androgen receptors, are involved in its pathogenesis. Higher concentrations of DHT, androgen receptors, and the enzyme 5 α -reductase, which converts testosterone to DHT, were found in balding scalps.^{2,3} Eunuchs who lack androgens, individuals lacking androgen receptors, and pseudohermaphrodites who lack 5 α -reductase all do not go bald.⁴⁻⁶ Androgenetic alopecia follows a polygenic inheritance pattern involving multiple genes, but the X chromosome is strongly associated with the disease, and the EDAR2 gene on the X chromosome was found to be highly associated with androgenetic alopecia.⁷ Finasteride, 5 α R inhibitor, and minoxidil are the current standard treatments for androgenetic alopecia.

Cosmeceutical Treatments

5 α -Reductase Inhibitors

The liposterolic extract of *Serenoa repens* (LSESr) and β -sitosterol are botanical extracts known to be 5 α -reductase (5 α R) inhibitors. Oral formulations of LSESr and β -sitosterol were administered *in vivo* to patients twice daily for around 4.6 months and were assessed for improvements in hair growth; six out of ten patients showed a significant positive response.⁸ Similarly, the ginsenoside Ro and the ginsenoside Rg3, specific to red ginseng, inhibit 5 α R. Furthermore, rhizomes of ginseng contain significantly greater levels of ginsenoside Ro than the roots. Topical treatment with red ginseng rhizome extract and ginsenoside Ro induced hair growth in mice under suppression by testosterone.⁹

Cuscuta reflexa Roxb, a parasitic plant found in tropical and temperate regions, is a promising 5 α R inhibitor for the treatment of androgenetic alopecia. Petroleum ether extract of *C. reflexa* was applied in a topical solution on the back of mice with hair growth suppressed by testosterone. Results revealed a significant decrease in hair loss as compared to the vehicle treated control. Furthermore, treatment with extract of *C. reflexa* significantly increased the ratio of hairs in the anagen/telogen phase of the mice to 1.6/1 as compared to 1/1 in the testosterone-treated mice. Follicular density (hairs/mm²) increased from 1.33 \pm 0.77 with testosterone treatment to 2.5 \pm 1 with *C. reflexa* treatment compared to 2.83 \pm 1.02 in the finasteride-treated standard group.¹⁰ The extract of *Thuja occidentalis* semen (TOS) is an inhibitor of the type 2 5 α R isoform. Topical treatment with TOS decreased sebum and sebaceous gland size and increased the anagen follicle count in mice injected with testosterone.¹¹

Other Cosmeceuticals

Petroleum ether extract of *Citrullus colocynthis* Schrad fruits may also be an effective treatment for androgenetic alopecia. Topical 2% and 5% solutions of the extract increased the anagen/telogen ratio of hair follicles in a time and dose dependent manner in mice injected with testosterone. *C. colocynthis* extract also increased follicular density and increased the number of anagen follicles more than treatment with finasteride did.¹² Green tea catechin Epicatechin-3-gallate increased hair follicle elongation in *ex vivo* hair follicle organ cultures and may be an effective treatment for AGA.¹³ Treatment with topical melatonin *in vivo* in patients with AGA increased hair density by 29% and 41% depending on treatment times. Furthermore, melatonin treatment significantly decreased the percentage of patients who had positive hair pull tests as well as the prevalence of seborrheic dermatitis.¹⁴ Melatonin also downregulated the expression of estrogen receptor alpha *ex vivo* in human hair follicle organ cultures, which may be a possible mechanism behind melatonin's activity.¹⁵

Certain retinoids affect hair cycle growth as well. Topical treatment with retinoids increased the length of anagen cycle and decreased the length of the telogen cycle in mice, and also enhanced the activity of minoxidil.¹⁶ The amino acid L-carnitine-L-tartrate (CT) treatment in hair follicle cells already in the anagen stage prolonged the duration of anagen and stimulated hair follicle elongation. CT also upregulated proliferation and downregulated apoptosis in follicular matrix keratinocytes.¹⁷ The commercial cosmetic hair growth product Fluridil increased the percentage of cells in the anagen phase *in vivo* in patients with androgenetic alopecia. Topical Fluridil was also a nonirritating and nonsensitizing agent that was also not resorbable.¹⁸ Similarly, treatment with the commercial product Crescina for four months improved hair resistance to pull and increased the percent of follicles in the anagen phase *in vivo* in humans.¹⁹ We are unaware of any direct human *in vivo* comparisons with finasteride or minoxidil. See also Table 25.1.

TABLE 25.1

Mechanism of Action of Cosmeceuticals for Androgenetic Alopecia

Cosmeceutical	Mechanism of Action	Reference
LSESr	5 α R inhibitor	8
β -sitosterol	5 α R inhibitor	8
Ro and Rg3	5 α R inhibitor	9
<i>C. Reflexa</i> extract	5 α R inhibitor	10
TOS	Type 2 5 α R inhibitor	11
<i>C. colocynthis</i> extract	Unknown	12
Epicatechin-3-gallate	↑ P-Erk, P-Akt	13
Melatonin	↓ EF α	15
Retinoids	↑ cRABP	16
L-carnitine-L-tartrate	↓ TGF- β 2, TGF- β RII ↓ caspase 3/7	17
Fluridil	↓ Androgen receptor Binding	18
Crescina	Unknown	19

Note: cRABP = cellular retinoic acid binding protein; EF α = estrogen receptor alpha.

REFERENCES

1. Courtois M et al. Hair cycle and alopecia. *Skin Pharmacol* 1994;7(1–2):84–9.
2. Sawaya ME, Price VH. Different levels of 5alpha-reductase type I and II, aromatase, and androgen receptor in hair follicles of women and men with androgenetic alopecia. *J Invest Dermatol* 1997;109(3):296–300.
3. Schweikert HU, Wilson JD. Regulation of human hair growth by steroid hormones. II. Androstenedione metabolism in isolated hairs. *J Clin Endocrinol Metab* 1974;39(6):1012–9.
4. Giltay EJ, Gooren LJ. Effects of sex steroid deprivation/administration on hair growth and skin sebum production in transsexual males and females. *J Clin Endocrinol Metab* 2000;85(8):2913–21.
5. Imperato-McGinley J et al. Steroid 5alpha-reductase deficiency in man: An inherited form of male pseudohermaphroditism. *Science* 1974;186(4170):1213–5.
6. Wilson JD, Roehrborn C. Long-term consequences of castration in men: Lessons from the Skoptzy and the eunuchs of the Chinese and Ottoman courts. *J Clin Endocrinol Metab* 1999;84(12):4324–31.
7. Prodi DA et al. EDAR2R is associated with androgenetic alopecia. *J Invest Dermatol* 2008;128(9):2268–70.
8. Prager N et al. A randomized, double-blind, placebo-controlled trial to determine the effectiveness of botanically derived inhibitors of 5-alpha-reductase in the treatment of androgenetic alopecia. *J Altern Complement Med* 2002;8(2):143–52.
9. Murata K et al. Effects of ginseng rhizome and ginsenoside Ro on testosterone 5alpha-reductase and hair re-growth in testosterone-treated mice. *Phytother Res* 2012;26(1):48–53.
10. Pandit S, Chauhan NS, Dixit VK. Effect of *Cuscuta reflexa* Roxb on androgen-induced alopecia. *J Cosmet Dermatol* 2008;7(3):199–204.
11. Park WS, Katz I, Lucky A et al. The extract of *Thuja occidentalis* semen inhibited 5alpha-reductase and androchronogenetic alopecia of B6CBAF1/j hybrid mouse. *J Dermatol Sci* 2003;31(2):91–8.
12. Dhanotia R et al. Effect of *Citrullus colocynthis* Schrad fruits on testosterone-induced alopecia. *Nat Prod Res* 2011;25(15):1432–43.
13. Kwon OS et al. Human hair growth enhancement *in vitro* by green tea epigallocatechin-3-gallate (EGCG). *Phytomedicine* 2007;14(7–8):551–5.
14. Fischer TW et al. Topical melatonin for treatment of androgenetic alopecia. *Int J Trichology* 2012;4(4):236–45.
15. Kobayashi H et al. A role of melatonin in neuroectodermal-mesodermal interactions: The hair follicle synthesizes melatonin and expresses functional melatonin receptors. *FASEB J* 2005;19(12):1710–2.
16. Bazzano G et al. Effect of retinoids on follicular cells. *J Invest Dermatol* 1993;101(1 Suppl):138S–42S.
17. Foitzik K et al. L-carnitine-L-tartrate promotes human hair growth *in vitro*. *Exp Dermatol* 2007;16(11):936–45.
18. Sovak M et al. Fluridil, a rationally designed topical agent for androgenetic alopecia: First clinical experience. *Dermatol Surg* 2002;28(8):678–85.
19. Buonocore D et al. Clinical efficacy of a cosmetic treatment by Crescina® human follicle stem cell on healthy males with androgenetic alopecia. *Dermatol Ther (Heidelb)* 2013;3(1):53–62.

Eczema, Xerosis, and Cutaneous Barrier Repair

M. Catherine Mack Correa, Diana R. Johnson, Julie B. Hirsch, and Katharine M. Martin

Introduction

Skin, being the primary interface between people and their environment, serves many functions vital to overall health. These functions include protection against pathogens, the blocking of ultraviolet (UV) light, water retention, heat regulation, and sensation, among others.¹ Skin forms a barrier around the human body, regulating the entry and exit of all manner of materials. Damage to this barrier not only results in increased transport and potential inflammation, but also causes the skin to become aesthetically displeasing. There are various conditions that result in damage to the skin barrier, many of which have etiologies that are only partially understood, making treatment difficult. Most of these conditions exist along a continuum of skin barrier quality. This continuum ranges from self-diagnosed sensitive skin with either no visible damage or only slight inflammation to severe eczema exhibiting multiple symptoms including redness, edema, pruritis, crusting, flaking, blistering, cracking, oozing, and/or bleeding (Figure 26.1). This chapter will focus on various conditions which involve compromised skin barrier function, as well as current treatments for repairing the barrier and methods to assess the efficiency of such treatments.

Skin is made of several distinct layers, with the outermost layer, the stratum corneum (SC), serving as the primary barrier.² Underlying the SC is the viable epidermis, made up of the stratum basale, the stratum spinosum, and the stratum granulosum (SG).³ The epidermis as a whole is constantly changing and self-renewing tissue. As cells from the surface of the stratum corneum are lost via desquamation, stem cells in the stratum basale divide to create new keratinocytes.³ Leaving the stratum basale, keratinocytes begin to differentiate during migration through the stratum spinosum and granulosum, and undergo structural and compositional changes including synthesis of a number of new structural proteins and lipids.³ At the SC/SG transition, keratinocytes undergo transformation into corneocytes. Corneocytes are largely flat, keratin filled, anucleated cells enveloped by a densely crosslinked protein layer.³ A layer of lipids is covalently bound to the protein envelope, which provides an interface between the hydrophilic corneocytes and hydrophobic intercellular lipids.^{3,4} The intercellular lipids primarily consist of ceramides, cholesterol, and free fatty acids that are tightly packed into lamellar formations and provide a barrier to water loss from the SC.^{2,5,6} Ceramides in particular have been shown to play a large role in maintaining proper lamellar organization.^{3,7} Corneocytes are connected via protein linkages termed corneodesmosomes, which are degraded toward the top of the SC leading to desquamation and sloughing off of dead cells. Corneocyte hydration is maintained through production of natural moisturizing factor (NMF), a collection of highly hygroscopic low-molecular-weight compounds derived from the breakdown of filaggrin and sweat.^{4,8,9} Ultimately, SC integrity is maintained as a result of the highly intricate organization of sufficiently hydrated corneocytes, lipid lamellae, and network of corneodesmosome linkages.

Conditions Involving Compromised Skin Barrier

While the quality of SC integrity and associated skin barrier function may be considered as a continuum, the physiological mechanisms which underlie a particular clinical presentation may be very different.

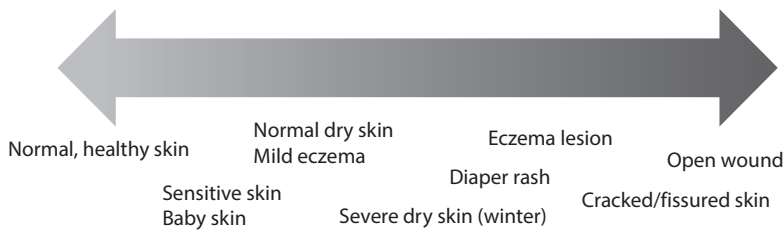

FIGURE 26.1 Schematic of the continuum of skin barrier conditions. On the left is normal, healthy skin. Moving to the right, an increase in barrier disruption leads to sensitive skin and normal dry skin. As the barrier becomes more disrupted, symptoms progress to a diaper rash or an eczematous lesion. An open wound or cracked/fissured skin represents complete disruption of the skin barrier function.

As such, patients will often present with similar symptoms, and yet be suffering from conditions with different etiologies, as is discussed below.

“Eczema,” “dermatitis,” and “atopic dermatitis” are terms for conditions and clinical characteristics, often used in combination, synonymously, and interchangeably, and sometimes incorrectly. *Eczema* is actually the broadest term and represents a range of skin diseases that present with multiple inflammatory symptoms including redness, swelling, itching, dryness, among others. Eczematous conditions and diseases encompass atopic dermatitis, allergic and irritant contact dermatitis, seborrheic dermatitis, neurodermatitis, and several others.¹⁰ *Dermatitis* is defined unspecifically as inflammation of the skin, and therefore any condition that causes the classic signs of inflammation—redness, swelling, heat and pain—can be called dermatitis. *Atopic dermatitis* (AD) is characterized by inflammation, pruritus, and chronic or relapsing eczematous lesions due to atopy. Atopy is a hyperallergic syndrome, with the propensity to develop hypersensitivity to environmental allergens characterized by an overproduction of IgE antibodies. Atopy extends beyond the skin and is often associated with other conditions such as rhinitis (hay fever), asthma, and allergic conjunctivitis.² While the term “atopic” or “atopy” is often used generally to describe the clinical phenotype of AD, a review demonstrated that up to two-thirds of individuals with AD are not atopic (determined by IgE sensitization), suggesting that often the term “AD” is not used accurately.¹¹

Atopic Dermatitis

AD is one of the most common childhood skin diseases and afflicts approximately 17% of children in the United States. The prevalence of AD has generally risen worldwide.¹² Forty-five percent of children affected by AD first present with symptoms by six months of age, with 60% presenting by one year and 85% presenting with clinical symptoms by five years of age.¹³ In approximately 60% of patients, the disease resolves prior to adulthood. In the adult population, AD has an estimated lifetime prevalence of 2%–10%.¹³ Patients with AD frequently develop other forms of atopy, including food allergies, asthma, or allergic rhinitis. Like AD, these other forms of atopy may either persist or resolve with age.^{14,15}

The etiology of AD remains an area of active research, as AD is a disease involving compromised skin barriers as well as immunological factors. Several predisposing factors have been identified, including genetics and environmental conditions. Genetics play a major role in AD, with parental history of atopic disease associated with both the development and severity of AD in infants. Genetic screening studies have identified more than 40 genes that have a positive association with AD.¹⁶ Environmental factors such as aeroallergens (e.g., pollen, pet dander, dust, and mites), food allergens, hard water, and soaps and detergents are known to contribute to the expression and severity of AD. It has been demonstrated that children with AD exhibit more pronounced sensitization to allergens compared with children without skin disorders, and AD severity was directly correlated with the degree of sensitization.¹⁷ There is also a “hygiene hypothesis” that postulates that the increase in AD and other atopic diseases is associated with improved modern hygiene which results in less exposure to infectious agents, endotoxins, noninfectious microbes, and other insults.¹⁸ Exposure to these agents is thought to “prime” the maturing immune system of infants and young children, and without this early stimulation the immune system overreacts

to otherwise innocuous agents such as dander or pollen. However, this association remains controversial. The understanding of the interplay between the developing immune system, environment, and genetics continues to evolve, and more research is necessary to fully understand the etiology of the development of atopic disease. The onset of AD is an intricate and complex process that involves intrinsic and extrinsic factors and remains incompletely understood.

The composition and structure of the barrier lipids of the SC is altered in patients with AD, particularly in lesional skin, compared to healthy skin.^{7,19} Studies have shown that patients with AD display reduced amounts of ceramides in the SC, altered concentrations of specific ceramide species, and differing organization of SC lipids.^{7,19–22} These changes to the SC lipid barrier contribute to increased transepidermal water loss (TEWL) in the skin of patients with AD.²³ The micro-fissures, scaling, and itching associated with AD can lead to excessive scratching, further compromising the epidermal barrier function by allowing irritant and allergen penetration into the SC.²⁴ Furthermore, corneocytes of patients with AD are significantly smaller than those in healthy individuals; as a result, the path of penetration through the SC is much shorter.²⁵

In addition, the skin microecology and microbiome is of great importance in AD. With the barrier compromised, allergens/microbes can penetrate into the skin through the layers of the SC, thereby interacting with antigen-presenting and immune-defector cells, and leading to inflammation and associated symptoms of redness, itching, swelling, etc. The antimicrobial barrier is weakened, which contributes to the higher incidence of skin infections seen in AD, primarily with colonization of *Staphylococcus aureus*.²⁶ The antimicrobial barrier function of the SC involves the skin's surface pH, the presence of commensal microbial species, and the endogenous production of antimicrobial peptides (AMPs).² Skin surface pH is elevated compared to normal skin in AD lesions, and to a lesser degree in non-lesional skin, which results in alterations of the skin microbiome.^{27–29} The microbiome of healthy skin is characterized by the high diversity of commensal bacteria thought to help deter the growth of pathogenic bacteria as well as interact with the host's immune functions, though these host–microbiota interactions are not fully understood.³⁰ Bacterial diversity has been shown to be lower in patients with AD, and decreases dramatically during a flare.^{31,32} Interestingly, clinical resolution of a lesion corresponds to a recovery of bacterial diversity.³² In addition, the elevated skin surface pH seen with AD has been associated with delays in epidermal barrier recovery and the activation of serine proteases that lead to the breakdown of corneodesmosomes.^{33,34} It was once believed that endogenous production of AMPs is reduced in patients with AD; however, recent evidence suggests that AMP production and expression are similar to levels observed in normal, healthy skin.³⁵ Therefore, it is speculated that the normal production of AMPs may not be sufficient to counteract the increase in bacterial colonization on the skin surface observed in patients with AD.²

Atopic dermatitis is also exacerbated by the increased inflammatory response, primarily triggered by the Th2 pathway. This differs from those who suffer from psoriasis, which typically shows an increase in the Th-1 pathway. Cytokines released by the Th-2 pathway include IL-4, IL-5, CCL8, and CCL17. These cytokines cause a downstream cascade that can lead to the itch/scratch cycle and chronic AD lesions.³⁶ It is necessary to keep in mind the increased inflammatory response when considering treatment options for AD patients.

Contact Dermatitis

Contact dermatitis is a form of eczema which results from direct exposure to allergens (allergic contact dermatitis) or irritants (irritant contact dermatitis). Irritant contact dermatitis can be divided into forms caused by chemical irritants or physical irritants. Chemical irritants include detergents, surfactants, organic solvents, or any chemical with extremely acidic or alkaline pH. Such chemicals are capable of effects which include removing of barrier lipids and damaging both corneocytes and the water-binding mechanisms of the skin barrier.³⁷ While high concentrations of irritants cause an acute effect, it is more common for a person to experience an accumulative, chronic effect due to being repeatedly exposed to chemical irritants in small doses.³⁷ Physical irritant contact dermatitis involves mechanical damage to the skin barrier, which triggers the inflammatory cascade.

Allergic contact dermatitis is the manifestation of an allergic response caused by contact with a substance. Unlike irritant contact dermatitis, allergic contact dermatitis requires both an induction phase,

which is the sensitization of the immune system, and an elicitation phase, which is the triggering of the immune response.³⁸ The contact allergens responsible for this type of dermatitis are generally soluble, low molecular weight molecules that have the physical and chemical properties which allow them to cross the SC of the skin and associate with epidermal proteins, forming a complete antigen that can elicit an immune response.³⁸ Many types of contact allergens are known to exist and include some metals such as nickel and gold, various plant derivatives, topical steroids, and many others.

As skincare products may contain ingredients that can induce either irritant or allergic contact dermatitis, many *in vitro* and *in vivo* measures have been developed to assess the irritancy and allergenicity of skincare products, and these are critical to the product development process. As these measures vary according to product form and ingredients, a full review of product safety assessments will not be discussed in this chapter.

Xerosis

Xerosis, or dry skin, is a clinical term describing skin states which result from excessive loss of water through the skin. Under normal circumstances, the SC is mostly impermeable to water and only allows a small amount of water loss. If the skin barrier is not maintained, the water content of the outermost layers of the SC is highly reduced and the SC becomes dysfunctional and brittle, resulting in pruritis, cracking, and scaling.⁴ In addition, the perturbed water gradients within the SC dysregulate the biological processes driving stratum corneum maturation events, including corneodesmolysis and desquamation.⁴

Xerosis usually does not have a single etiology, but rather complex interactions among a variety of individual and environmental factors ultimately produce dry skin. Among these causes are genetic factors and inherited disorders relating to the structure and function of the epidermis such as ichthyosis.³⁹ Dryness may also be secondary to a pathological condition, such as diabetes or renal failure, deficiency of vitamin A or D, or severe sunburn.³⁹ Certain behaviors are also related to xerosis, particularly excessive bathing/hand washing using harsh soaps or frequent exposure to detergents.³⁹ Environmental factors are particularly known to play a large role, especially low temperature and the related low relative humidity, which results in less water in the air and increases the gradient driving diffusion through the SC.^{39,40} Also, people of advanced age tend to suffer from dry skin more commonly due to decreased sweat and sebaceous gland activity, which predisposes their skin to moisture depletion.⁴¹

The pathophysiology of xerosis can be described as a cyclical model, involving interconnected biological pathways and feedback mechanisms leading to a progressive worsening without intervention.⁴ The SC uses three main mechanisms to hold onto water: intercellular lamellar lipids, corneocytes, and NMFs. The intercellular lamellar lipids' physical conformation forms a lamellar phase which provides a tight and semi-permeable barrier to the passage of water through the tissue. The presence of fully matured corneocytes connected by corneodesmosomes influences the tortuosity of the SC and thereby the diffusion path length of water. Lastly, the presence of both intracellular and extracellular water absorbing materials, that is, NMFs, affects the permeability of water in and out of the SC.⁴ Initiation of the xerotic cascade begins with the disruption of the water-holding mechanisms of the SC.

Examples of precipitating factors include low environmental temperature and humidity, abrupt changes in environmental conditions (particularly those of modern indoor climate-controlled environments), surfactant dissolution of stratum corneum lipid and NMF, and/or chronological aging and genetics.⁴ The effects on a short time scale are generally physical phenomena: development of a steeper SC hydration gradient, reduced recondensation on the SC surface, a corresponding increase in TEWL, and a consequent further drop in SC water concentration, perpetuating the cycle.⁴ As a result, the plasticity of the skin is reduced, which increases the risk of mechanical damage to the skin barrier.^{42–45} The skin barrier may be further impaired by surfactant interaction with the lipid lamellae, including extraction of lipids and disorganization of the lamellae, during normal skincare routines such as bathing.^{46–48} Disruption of the lipid lamellae and the corneocyte–lipid envelope allows NMF to leach out of corneocytes, reducing the SC water-holding ability and leading to further dehydration.⁴

On a longer time scale, a biological cascade is initiated as the skin attempts to restore normal TEWL and hydration properties. This cascade features an induction of a hyper-proliferative state resulting in enhanced keratinocyte proliferation and consequent hyperkeratosis mediated by the production and

secretion of cytokines and growth factors.^{4,45,46} There is a loss in efficiency of desquamation, as a result of reduced activity of desquamatory enzymes at the surface of the SC, causing scaling, thickening, and loss of ability to absorb water.^{4,49} Due to the short-term physical transport effects and long-term biological cascade, it must be stressed that the clinical endpoint of xerosis cannot be regarded as static, but rather as a cycle that, without intervention, tends to perpetuate itself.

Special Considerations for Infants

While infant skin is often used to represent the cosmetic ideal for adults, compared to adult skin, infant skin is more prone to the conditions described above, such as atopic dermatitis and irritant contact dermatitis.⁵⁰ Therefore, a keen understanding of healthy infant skin is needed both to properly treat skin-barrier-damaging conditions in infants and to appreciate how infant skin differs from adult skin for cosmetic and clinical purposes. Technical innovations over the past two decades in the realm of non-invasive *in vivo* measurement techniques, including electrical methods and imaging, microscopy, and spectroscopy, have enabled quantitative measurement of the properties of infant skin.⁵⁰ Studies incorporating non-invasive skin measurements have demonstrated several differences between skin during the first years of life and adult skin.^{51–56} Particularly, infant skin has been shown to have a thinner epidermis, a thinner SC, and smaller corneocytes until at least two years of age.⁵⁵ The water-handling properties are not fully developed before the end of the first year; for example, infant SC contains more water and less NMF.⁵⁴ In diseases such as AD that often develop in early life and resolve with age, disease progression may be related to the differences in the infant skin barrier and the skin maturation process.

Current Treatments and Barrier Repair

While palliative treatments may be aimed at presenting symptoms, treatments of the underlying conditions depend on recognizing the underlying cause of the symptoms. Therefore, any of the treatment regimens made up from the choices below must take into consideration the specific condition being treated, so that the treatment will provide relief for the patient's symptoms as well as treat the cause.

There is a large variety of treatments available on the market designed to help maintain skin moisturization and barrier quality, including cosmetic moisturizers, over-the-counter (OTC) formulations containing monographed skin protectant ingredients, and prescription medical devices. Most of these products contain some water. However, water within topical treatments only delivers a transient moisturization effect, and it is the other components of the product that truly define the level of benefit. The function of moisturizer formulations may broadly be categorized as humectant, occlusive, and emollient.⁵⁷

Humectants attract and hold water in the skin, both acting from the inside out (i.e., moisture from the deep dermis to the SC) and from the outside in. Polyols are highly effective humectants, with glycerol generally regarded as being the most effective.⁵⁸ Glycerol-containing products work by binding and holding water and minimizing water loss. In addition, glycerol has been shown to prevent humidity-induced crystal phase transitions in SC lipids, thereby improving SC barrier function.⁵⁷ Recently, glycerol has also been shown to be corneodesmolytic, aiding in the proteolytic degradation of the corneodesmosomes and facilitating desquamation.⁵⁹ Occlusives form a layer on the surface of the skin, retarding the evaporation of water. Anhydrous petrolatum reduces water loss by more than 98%, whereas other oils only manage a 20%–30% reduction.⁵⁹ Petrolatum also diffuses into the intercellular lipid domains, possibly contributing to its efficacy.⁶⁰ Emollients are oils and lipids that spread easily on skin, providing partial occlusion that hydrates and makes the SC soft, supple, and flexible.

In the moisturizer category, a special note should be made for products containing colloidal oatmeal. While nearly two dozen compounds are recognized by the FDA as having skin protective activity, including dimethicone, mineral oil (either 50%–100%, or 30%–35% when used with colloidal oatmeal), petrolatum, sodium bicarbonate, cocoa butter, glycerin, and lanolin, only colloidal oatmeal, when used within specific levels, is indicated for relief of minor skin irritation and itching due to eczema.^{16,61} Colloidal oatmeal is a natural product derived from oat grains (*Avena sativa*) with a complex chemical composition including polysaccharides, lipids, proteins, flavonoids, minerals, and vitamins.⁶² Daily use

of colloidal oatmeal formulations have been shown to improve a range of clinical outcomes in patients with AD, including physician assessments, itch, dryness, and overall quality of life.⁶³

Specific Physiologic Targets

In addition to the general functions of moisturizers described previously, formulations may also include ingredients designed to act upon specific physiological targets for enhanced efficacy. Identification of these specific physiological targets for treatment of compromised barrier conditions is a highly active area in the field of skin research. For the purposes of this chapter, we will review three examples of targets particularly relevant to atopic dermatitis and xerosis.

Proteolytic enzymes play a critical role in maintaining the function and integrity of the SC through regulating the rate of desquamation.^{64,65} The “optimum” rate of desquamation may be considered to be a careful balance of the removal of dehydrated corneocytes at the surface of the SC, maintaining flexibility and elasticity, with maintenance of sufficient SC to provide the necessary barrier properties. This balance is partly maintained through activation and inactivation of serine proteases within the SC responsible for degrading the corneodesmosome linkages between corneocytes (KLK5, KLK7, and KLK14).⁵ The regulation processes governing activity of these proteases are highly complex, and will not be discussed in detail in this chapter. For our purposes, it is sufficient to note that dysregulation of desquamatory protease activity in the SC is often involved in conditions of compromised skin barrier. Expression of desquamatory proteases, particularly KLK7, is increased in patients with AD.⁶⁶ In addition to elevated expression, the neutral or slightly alkaline skin pH also observed in AD results in higher activity of the desquamatory proteases and contributes to the thinner SC and compromised barrier function characteristic of AD.⁵ Conversely, the activity of desquamatory proteases is diminished in xerosis due in part to the altered water gradient in the SC. The reduction of desquamatory protease activity results in clumps of partially detached, dehydrated corneocytes retained at the surface of the SC, commonly known as flaking or scaling.⁶⁷ Treatment approaches designed to normalize desquamatory protease activity include maintenance of acidic pH and an appropriate water gradient within the SC, biological activators and inhibitors of these proteases, as well as inclusion of enzymes within the formulation.

Maintenance of the SC lipid lamellae has also been widely investigated as a treatment target. Recent studies comparing levels of the major SC lipids in patients with AD and other skin conditions have shown alterations in the levels and ratios of ceramides, cholesterol, and free fatty acids, as well as differences in levels of specific classes of ceramides.^{7,19–21,68–70} Treatments that target the SC barrier lipids are designed to help rebuild/repair the lipid lamellar structure of the barrier. Traditional moisturizers as discussed above are structured as water-in-oil or oil-in-water emulsions and have been shown to be useful to varying degrees, but recent research has shown the advantage of using lamellar-forming ingredients such as ceramides, pseudoceramides, and phospholipids in the relief of dry skin.⁷¹ Additionally, mixtures of physiologic lipids in specific ratios similar to those naturally found on skin have been shown to improve the rate of barrier repair.^{72,73} A prescription barrier device containing such a mixture (EpiCeram, PuraCap Pharmaceutical LLC, South Plainfield, New Jersey) is indicated for the treatment of AD.

NMF is a collection of low-molecular-weight compounds capable of absorbing water and includes free amino acids and various derivatives of these amino acids such as 2-pyrrolidone-5-carboxylic acid (PCA), urocanic acid, inorganic salts, and sugars, as well as lactic acid and urea.^{74,75} Because NMF components are water soluble, they are easily leached from the cells with water contact, leading to the commonly observed effect of repeated contact with water actually making the skin drier. Only approximately one-third of water contained within the stratum corneum is bound, with the remainder being free water, and increasing the level of free water has no effect on the elasticity of the stratum corneum.⁷⁶ Thus, the NMF-bound water provides the skin with its elastic qualities; therefore, replacing or replenishing the supply of the NMF in the skin through the external application of NMF-containing products can be used as a successful approach for the treatment of barrier-damaging conditions such as xerosis. Several NMF components have been used for decades in moisturizing vehicles before their mechanism of action was fully understood. For example, urea has been included in moisturizing creams as far back as 1943.⁷⁵ Now it is known that urea levels are reduced in patients with AD and in elderly skin,^{77,78} and that topical application of urea or its precursor arginine has been shown to alleviate these urea deficits.^{8,78} Meanwhile,

lactate, used as far back as 1946, has been shown to improve and prevent the reappearance of symptoms of xerosis.⁷⁵ L-lactic acid and D,L-lactic acid appear to work by stimulating the synthesis of ceramides in the stratum corneum.⁷⁹ PCA is the most prevalent single component in NMF and has been shown to be reduced in the outermost layers of the skin due to xerosis from overuse of soap and/or age. Topical application of PCA has been widely reported to alleviate the symptoms of dry skin.⁷⁵

Many cleansing routines designed to help maintain the appearance and integrity of the skin and its barrier can actually have an exacerbating effect on certain pathological conditions affecting the skin barrier.^{80,81} The amphiphilic behavior of surfactants cause them to aggregate in water and form into micelles once their concentration has reached a certain concentration, known as the critical micelle concentration (CMC).^{80,82} In the past it was assumed that micelles were too large to penetrate into the SC. However, the dose-dependent irritation response that is usually observed when surfactants are applied to skin as a function of increasing concentration suggests this is not the case.^{83–85} Therefore, current technologies are being developed using the concept that both monomeric and micellar surfactant species can contribute to irritation. Among these technologies are hydrophobically-modified polymers (HMPs), which have been designed to bind to surfactant micelles via polymer–surfactant association, creating polymer–surfactant complexes that are too large to penetrate into healthy living tissue and lowering the concentration of free micelles in solution. Results of clinical studies have shown that HMP-based gentle cleansers were very well tolerated by sensitive-skin populations, with no adverse effects noted, making such cleansers ideal for patients with compromised barrier conditions such as xerosis or eczema.⁸⁶

Clinical Assessment of Moisturizer Efficacy

Protocols for the testing for cosmetic topical treatments generally contain the following elements: standardization of subjects' skin conditions through a washout period with a specified cleanser and a period of once or twice daily treatment, ranging from one day to several months. Assessments may also continue after the treatment period (termed regression) to evaluate potential longer term benefits of the treatment. There are various methods that are used to assess benefits, each of which has its own strengths and weaknesses.

TEWL is the measurement of water lost by the epidermal layer to the surrounding atmosphere via either diffusion or evaporation, and is the standard non-invasive measure of skin barrier quality. Some water is lost via normal processes of the body, most notably sweat production; however, increases in TEWL are generally caused by damage to the skin barrier, such as seen in the conditions already discussed. As such, it is often considered to be the gold standard for evaluation of skin barrier integrity. However, TEWL measurements are affected by external environmental conditions (which may fluctuate during the course of clinical studies) and are highly variable within subject populations.⁸⁷ In addition, changes in SC hydration must also be considered along with changes in TEWL when interpreting clinical results. If a treatment increases water content in the SC without affecting barrier integrity, TEWL will increase simply due to diffusion. Because of these factors, other methods of assessing barrier function are needed in conjunction with TEWL to ensure accurate assessment of the clinical benefits of moisturizers.

Skin hydration may be measured non-invasively through electrical measures (conductance, capacitance) and spectroscopic measures (infrared, Raman).^{88–90} An increase in water content of the skin facilitates ion flow and therefore increases skin conductance. The measurement of skin conductance is relatively straightforward and there are several commercially available instruments designed specifically for measuring skin. However, factors such as temperature and humidity have been shown to change conductance levels. Also, sweat production has an effect on measured skin conductance due to the salts contained in the sweat residue which remain on the skin surface.⁹¹ Spectroscopic methods such as attenuated total reflectance—Fourier transform infrared spectroscopy (ATR-FTIR) and Raman spectroscopy directly measure water. Such methods are a more exact means of evaluating the water content in the epidermis and are non-invasive, but require specialized equipment that may not be available at all facilities.

Additional assessment methods of clinical efficacy include digital imaging and video microscopy to record erythema and visual flaking or scaling; reflectance confocal microscopy (RCM), optical

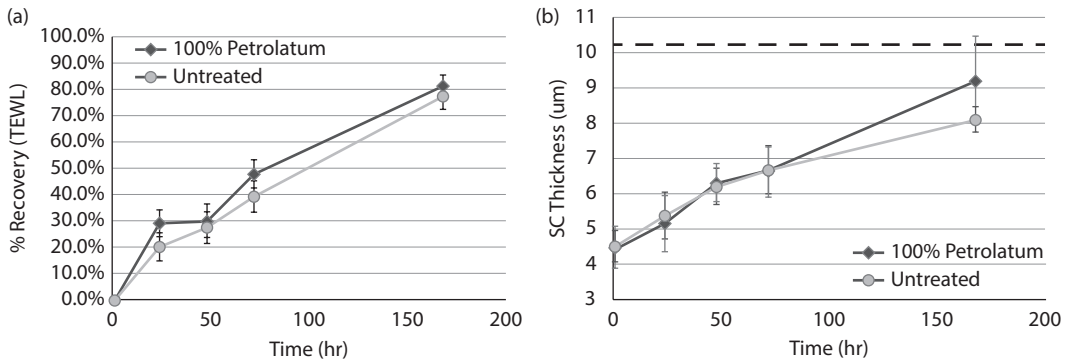

FIGURE 26.2 Measurement of barrier recovery after tape-stripping. Transepidermal water loss (TEWL) and stratum corneum (SC) thickness changed linearly over time but did not fully recover after one week. (a) Percent TEWL recovery over time. The percent TEWL recovery parameter was calculated by the change in TEWL from immediately post tape stripping/change in TEWL from baseline. (b) SC thickness recovery over time. SC thickness was measured through reflectance confocal microscopy. Data is presented as mean \pm standard error of the mean. The dotted line indicates the average SC thickness in an adjacent, untape-stripped control site.

coherence tomography, and ultrasound to measure epidermal morphology, including the thicknesses of the SC and epidermis; and fluorescence confocal microscopy to measure the penetration of a marker dye through the SC.^{67,92–94} These measurement techniques, along with optimized clinical protocols, may provide greater sensitivity in differentiating the effects of various moisturizers.

The challenges in assessing skin barrier repair in a clinical setting are apparent when considering the seemingly contradictory reports of effects of occlusion on skin barrier repair. In different studies, occlusion or application of occlusive materials has been reported to accelerate, to impair, and to have no effect on skin barrier recovery.^{72,95,96} However, many factors including test subjects (animal model or human), cause of initial barrier disruption (disease state, induced disruption by surfactant, or mechanical means), timepoints and endpoints assessed, and finally “control” or “placebo” treatment, will influence the study results and subsequent interpretation of a benefit. For example, a small clinical study in our laboratory showed no statistical difference in barrier repair in tape-stripped sites treated with petrolatum versus untreated controls. Nineteen healthy Caucasian subjects with no history of skin disease were enrolled, and two sites on the upper inner arm were tape-stripped to reach three times the baseline TEWL value. TEWL (Evaporimeter, cyberDERM, Bromall PA) and erythema (cross polarized digital imaging, custom built) were measured at baseline, immediately after tape stripping, 24 hours, 48 hours, 72 hours, and seven days. In a subset of subjects ($n = 8$), SC thickness (Vivascope 1500, Caliber ID, Rochester, New York) was measured at all timepoints except baseline. SC thickness was measured on an adjacent control site. Subjects applied white petrolatum to one site twice daily and the other site served as an untreated control. There was no difference between the TEWL recovery or SC thickness in the petrolatum cell and the untreated cell (Figure 26.2). However, the absence of an observed effect may be due to the fairly moderate initial barrier disruption, the choice of the upper inner arm as test site, and/or the timepoints chosen for assessments. The results from this study underscore the importance of clinical protocol design and the need for non-invasive, highly sensitive measures of skin barrier repair.

Conclusion

It is evident that significant advances have been made in the understanding of the etiology and pathophysiology of compromised skin barrier conditions and diseases. Innovations in analytical techniques and development of model systems have accelerated the rate of research as we answer the questions that we know enough to ask, and have opened entirely new areas to explore as we discover new questions yet to be answered. The field is dynamic and exciting, and promises to yield rich insight into skin barrier function and novel treatments for patients with compromised skin conditions.

Acknowledgments

The authors thank Kristopher De Young for editorial assistance in preparing this manuscript.

REFERENCES

1. Marks JG, Miller JJ et al. *Lookingbill and Marks' Principles of Dermatology*, 4th edn. Philadelphia, PA: Saunders Elsevier; 2006.
2. Mack Correa MC, Nebus J. Management of patients with atopic dermatitis: The role of emollient therapy. *Dermatol Res Pract* 2012;2012:836931.
3. Bouwstra JA, Ponc M. The skin barrier in healthy and diseased state. *Biochim Biophys Acta* 2006;1758(12):2080–95.
4. Rawlings AV, Matts PJ. Stratum corneum moisturization at the molecular level: An update in relation to the dry skin cycle. *J Invest Dermatol* 2005;124(6):1099–110.
5. Cork MJ, Danby SG et al. Epidermal barrier dysfunction in atopic dermatitis. *J Invest Dermatol* 2009;129(8):1892–908.
6. Groen D, Poole DS et al. Is an orthorhombic lateral packing and proper lamellar organization important for the skin barrier function? *Biochimica et Biophysica Acta* 2011;1808(6):1529–37.
7. Janssens M, van Smeden J et al. Lamellar lipid organization and ceramide composition in the stratum corneum of patients with atopic eczema. *J Invest Dermatol*. 2011;131(10):2136–8.
8. Loden M. Role of topical emollients and moisturizers in the treatment of dry skin barrier disorders. *Am J Clin Dermatol* 2003;4(11):771–88.
9. Tabachnick J, LaBadie JH. Studies on the biochemistry of epidermis. IV. The free amino acids, ammonia, urea, and pyrrolidone carboxylic acid content of conventional and germ-free albino guinea pig epidermia. *J Invest Dermatol* 1970;54(1):24–31.
10. Johansson SG, Bieber T et al. Revised nomenclature for allergy for global use: Report of the nomenclature review committee of the world allergy organization, October 2003. *J Allergy Clin Immunol* 2004;113(5):832–6.
11. Flohr C, Johansson SG et al. How atopic is atopic dermatitis? *J Allergy Clin Immunol* 2004;114(1):150–8.
12. Spergel JM. Epidemiology of atopic dermatitis and atopic march in children. *Immunol Allergy Clin North Am* 2010;30(3):269–80.
13. Bieber T. Atopic dermatitis. *Ann Dermatol*. 2010y;22(2):125–37.
14. Barnetson RS, Rogers M. Childhood atopic eczema. *BMJ* 2002;324(7350):1376–9.
15. Liu AH. The allergic march of childhood. *MedSci Update* 2006;23(1):1–7.
16. Barnes KC. An update on the genetics of atopic dermatitis: Scratching the surface in 2009. *J Allergy Clin Immunol* 2010;125(1):16–29 e1–11; quiz 30–1.
17. Schafer T, Heinrich J et al. Association between severity of atopic eczema and degree of sensitization to aeroallergens in schoolchildren. *J Allergy Clin Immunol* 1999;104(6):1280–4.
18. Okada H, Kuhn C et al. The 'hygiene hypothesis' for autoimmune and allergic diseases: An update. *Clin Exp Immunol* 2010;160(1):1–9.
19. Pilgram GS, Vissers DC et al. Aberrant lipid organization in stratum corneum of patients with atopic dermatitis and lamellar ichthyosis. *J Invest Dermatol* 2001;117(3):710–7.
20. Di Nardo A, Wertz P et al. Ceramide and cholesterol composition of the skin of patients with atopic dermatitis. *Acta Derm Venereol* 1998;78(1):27–30.
21. Imokawa G, Abe A et al. Decreased level of ceramides in stratum corneum of atopic dermatitis: An etiologic factor in atopic dry skin? *J Invest Dermatol* 1991;96(4):523–6.
22. Jungersted JM, Scheer H et al. Stratum corneum lipids, skin barrier function and filaggrin mutations in patients with atopic eczema. *Allergy* 2010;65(7):911–8.
23. Werner Y, Lindberg M. Transepidermal water loss in dry and clinically normal skin in patients with atopic dermatitis. *Acta Derm Venereol* 1985;65(2):102–5.
24. Kircik L. A nonsteroidal lamellar matrix cream containing palmitoylethanolamide for the treatment of atopic dermatitis. *J Drugs Dermatol* 2010;9(4):334–8.
25. Kashibuchi N, Hirai Y et al. Three-dimensional analyses of individual corneocytes with atomic force microscope: Morphological changes related to age, location and to the pathologic skin conditions. *Skin Res Technol* 2002;8(4):203–11.

26. Baker BS. The role of microorganisms in atopic dermatitis. *Clin Exp Immunol* 2006;144(1):1–9.
27. Eberlein-Konig B, Schafer T et al. Skin surface pH, stratum corneum hydration, trans-epidermal water loss and skin roughness related to atopic eczema and skin dryness in a population of primary school children. *Acta Derm Venereol* 2000;80(3):188–91.
28. Seidenari S, Giusti G. Objective assessment of the skin of children affected by atopic dermatitis: A study of pH, capacitance and TEWL in eczematous and clinically uninvolved skin. *Acta Derm Venereol* 1995;75(6):429–33.
29. Rippke F, Schreiner V et al. Stratum corneum pH in atopic dermatitis: Impact on skin barrier function and colonization with *Staphylococcus aureus*. *Am J Clin Dermatol* 2004;5(4):217–23.
30. Chen YE, Tsao H. The skin microbiome: Current perspectives and future challenges. *J. Am. Acad. Dermatol.* 2013;69(1):143–55.
31. Bibel DJ, Aly R et al. Competitive adherence as a mechanism of bacterial interference. *Can J Microbiol* 1983;29(6):700–3.
32. Kong HH, Oh J et al. Temporal shifts in the skin microbiome associated with disease flares and treatment in children with atopic dermatitis. *Genome Res* 2012;22(5):850–9.
33. Hachem JP, Man MQ et al. Sustained serine proteases activity by prolonged increase in pH leads to degradation of lipid processing enzymes and profound alterations of barrier function and stratum corneum integrity. *J Invest Dermatol* 2005;125(3):510–20.
34. Mauro T, Holleran WM et al. Barrier recovery is impeded at neutral pH, independent of ionic effects: Implications for extracellular lipid processing. *Arch Dermatol Res* 1998;290(4):215–22.
35. Schittek B. The antimicrobial skin barrier in patients with atopic dermatitis. *Curr Probl Dermatol* 2011;41:54–67.
36. Islam SA, Luster AD. T cell homing to epithelial barriers in allergic disease. *Nat Med.* 2012;18(5):705–15.
37. Mathias CG, Maibach HI. Dermatotoxicology monographs I. Cutaneous irritation: Factors influencing the response to irritants. *Clin Toxicol* 1978;13(3):333–46.
38. Kimber I, Basketter DA et al. Allergic contact dermatitis. *Int Immunopharmacol* 2002;2(2–3):201–11.
39. Loden M. Do moisturizers work? *J Cosmet Dermatol* 2003;2(3–4):141–9.
40. Boccanfuso SM, Cosmet L et al. Skin xerosis. Clinical report on the effect of a moisturizing soap bar. *Cutis* 1978;21(5):703–7.
41. Norman RA. Xerosis and pruritus in elderly patients, Part 1. *Ostomy Wound Manage* 2006;52(2):12–4.
42. Christensen MS, Hargens CW 3rd et al. Viscoelastic properties of intact human skin: Instrumentation, hydration effects, and the contribution of the stratum corneum. *J Invest Dermatol* 1977;69(3):282–6.
43. Cooper ER, Missel PJ et al. Mechanical properties of dry, normal and glycerol-treated skin as measured by the gas-bearing electrodynamicometer. *J Cosmet Sci* 1985;36:335–48.
44. Matts PJ. Hardware and measurement principles: The gas-bearing electrodynamicometer and linear skin rheometer. In: Elsner P, Beradesca E, et al., eds. *Bioengineering of the Skin: Skin Biomechanics*, Boca Raton, FL: CRC Press; 2002.
45. Matts PJ, Goodyer E. A new instrument to measure the mechanical properties of human skin *in vivo*. *J Cosmet Sci* 1998;49:321–33.
46. Rawlings AV, Watkinson A et al. Abnormalities in stratum corneum structure lipid composition and desmosome degradation in soap-induced winter xerosis. *J Soc Cosmet Chem* 1994;45:203–20.
47. Mao G, Flach CR et al. Imaging the distribution of sodium dodecyl sulfate in skin by confocal Raman and infrared microspectroscopy. *Pharm Res* 2012;29(8):2189–201.
48. Saad P, Flach CR et al. Infrared spectroscopic studies of sodium dodecyl sulphate permeation and interaction with stratum corneum lipids in skin. *Int J Cosmet Sci* 2012;34(1):36–43.
49. Simon M, Bernard D et al. Persistence of both peripheral and non-peripheral corneodesmosomes in the upper stratum corneum of winter xerosis skin versus only peripheral in normal skin. *J Invest Dermatol* 2001;116(1):23–30.
50. Stamatas GN, Nikolovski J et al. Infant skin physiology and development during the first years of life: A review of recent findings based on *in vivo* studies. *Int J Cosmet Sci* 2011;33(1):17–24.
51. Fluhr JW, Darlenski R et al. Infant epidermal skin physiology: Adaptation after birth. *Br J Dermatol* 2012;166(3):483–90.
52. Fluhr JW, Pfisterer S et al. Direct comparison of skin physiology in children and adults with bioengineering methods. *Pediatr Dermatol* 2000;17(6):436–9.

53. Hoeger PH, Enzmann CC. Skin physiology of the neonate and young infant: A prospective study of functional skin parameters during early infancy. *Pediatr Dermatol* 2002;19(3):256–62.
54. Nikolovski J, Stamatias GN et al. Barrier function and water-holding and transport properties of infant stratum corneum are different from adult and continue to develop through the first year of life. *J Invest Dermatol* 2008;128(7):1728–36.
55. Stamatias GN, Nikolovski J et al. Infant skin microstructure assessed *in-vivo* differs from adult skin in organization and at the cellular level. *Pediatr Dermatol* 2010;27(2):125–31.
56. Mack MC, Tierney NK et al. Development of solar UVR-related pigmentation begins as early as the first summer of life. *J Invest Dermatol* 2010;130:2335–8.
57. Rawlings AV, Canestrari DA et al. Moisturizer technology versus clinical performance. *Dermatol Ther* 2004;17 Suppl 1:49–56.
58. Johnson AW. The skin moisturizer marketplace. In: Leyden J, Rawlings AV, eds, *Skin Moisturization*, New York, NY: Marcel Dekker, Inc.; 2002, pp.1–30.
59. Rawlings A, Harding C et al. The effect of glycerol and humidity on desmosome degradation in stratum corneum. *Arch Dermatol Res* 1995;287(5):457–64.
60. Ghadially R, Halkier-Sorensen L et al. Effects of petrolatum on stratum corneum structure and function. *J Am Acad Dermatol* 1992;26(3 Pt 2):387–96.
61. Shuren J. Skin protectant drug products for the over-the-counter human use, final monograph. *Federal Register* 2003;68(107):33362–81.
62. Kurtz ES, Wallo W. Colloidal oatmeal: History, chemistry and clinical properties. *J Drugs Dermatol* 2007;6(2):167–70.
63. Fowler JF, Nebus J et al. Colloidal oatmeal formulations as adjunct treatments in atopic dermatitis. *J Drugs Dermatol* 2012;11(7):804–7.
64. Meyer-Hoffert U, Schroder JM. Epidermal proteases in the pathogenesis of rosacea. *J Investig Dermatol Symp Proc* 2011;15(1):16–23.
65. Rawlings AV, Voegeli R. Stratum corneum proteases and dry skin conditions. *Cell Tissue Res* 2013;351(2):217–35.
66. Komatsu N, Saijoh K et al. Human tissue kallikrein expression in the stratum corneum and serum of atopic dermatitis patients. *Exp Dermatol* 2007;16(6):513–9.
67. Chu M, Kollias N. Documentation of normal stratum corneum scaling in an average population: Features of differences among age, ethnicity and body site. *Br J Dermatol* 2011;164(3):497–507.
68. Jungersted JM, Helligren LI et al. Lipids and skin barrier function—a clinical perspective. *Contact Dermatitis* 2008;58(5):255–62.
69. Janssens M, Mulder AA et al. Electron diffraction study of lipids in non-lesional stratum corneum of atopic eczema patients. *Biochimica et Biophysica Acta (BBA)—Biomembranes* 2013;1828(8):1814–21.
70. Janssens M, van Smeden J et al. Increase in short-chain ceramides correlates with an altered lipid organization and decreased barrier function in atopic eczema patients. *J Lipid Res* 2012;53(12):2755–66.
71. Pennick G, Chavan B et al. The effect of an amphiphilic self-assembled lipid lamellar phase on the relief of dry skin. *Int J Cosmet Sci* 2012;34(6):567–74.
72. Mao-Qiang M, Brown BE et al. Exogenous nonphysiologic vs physiologic lipids. Divergent mechanisms for correction of permeability barrier dysfunction. *Arch Dermatol* 1995;131(7):809–16.
73. Man MM, Feingold KR et al. Optimization of physiological lipid mixtures for barrier repair. *J Invest Dermatol* 1996;106(5):1096–101.
74. Clar EJ, Fourtanier A. Pyrrolidone carboxylic acid and the skin. *Int J Cosmet Sci* 1981;3(3):101–13.
75. Harding CR, Watkinson A et al. Dry skin, moisturization and corneodesmolysis. *Int J Cosmet Sci* 2000;22(1):21–52.
76. Jokura Y, Ishikawa S et al. Molecular analysis of elastic properties of the stratum corneum by solid-state ¹³C-nuclear magnetic resonance spectroscopy. *J Invest Dermatol* 1995;104(5):806–12.
77. Loden M, Andersson AC et al. Instrumental and dermatologist evaluation of the effect of glycerine and urea on dry skin in atopic dermatitis. *Skin Res Technol* 2001;7(4):209–13.
78. Nenoff P, Donaubaue K et al. Topically applied arginine hydrochloride. Effect on urea content of stratum corneum and skin hydration in atopic eczema and skin aging. *Hautarzt* 2004;55(1):58–64 (in German).
79. Rawlings AV, Davies A et al. Effect of lactic acid isomers on keratinocyte ceramide synthesis, stratum corneum lipid levels and stratum corneum barrier function. *Arch Dermatol Res* 1996;288(7):383–90.

80. Ananthapadmanabhan KP, Moore DJ et al. Cleansing without compromise: The impact of cleansers on the skin barrier and the technology of mild cleansing. *Dermatol Ther* 2004;17(Suppl 1):16–25.
81. Imokawa G, Akasaki S et al. Importance of intercellular lipids in water-retention properties of the stratum corneum: Induction and recovery study of surfactant dry skin. *Arch Dermatol Res* 1989;281(1):45–51.
82. Abbas S, Goldberg JW et al. Personal cleanser technology and clinical performance. *Dermatol Ther* 2004;17 Suppl 1:35–42.
83. Ghosh S, Blankschtein D. Why is sodium cocoyl isethionate (SCI) mild to the skin barrier?—An *in vitro* investigation based on the relative sizes of the SCI micelles and the skin aqueous pores. *J Cosmet Sci* 2007;58(3):229–44.
84. Moore PN, Puvvada S et al. Challenging the surfactant monomer skin penetration model: Penetration of sodium dodecyl sulfate micelles into the epidermis. *J Cosmet Sci* 2003;54(1):29–46.
85. Moore PN, Shiloach A et al. Penetration of mixed micelles into the epidermis: Effect of mixing sodium dodecyl sulfate with dodecyl hexa(ethylene oxide). *J Cosmet Sci* 2003;54(2):143–59.
86. Draelos Z, Hornby S et al. Hydrophobically modified polymers can minimize skin irritation potential caused by surfactant-based cleansers. *J Cosmet Dermatol* 2013 Dec;12(4):314–21.
87. Chilcott RP, Dalton CH et al. Transepidermal water loss does not correlate with skin barrier function *in vitro*. *J Invest Dermatol* 2002;118(5):871–5.
88. Brancalion L, Bamberg MP et al. Attenuated total reflection-Fourier transform infrared spectroscopy as a possible method to investigate biophysical parameters of stratum corneum *in vivo*. *J Invest Dermatol* 2001;116(3):380–6.
89. Caspers PJ, Lucassen GW et al. Automated depth-scanning confocal raman microspectrometer for rapid *in-vivo* determination of water concentration profiles in human skin. *Journal of Raman Spectroscopy* 2000;31:813–8.
90. Tagami H, Ohi M et al. Evaluation of the skin surface hydration *in vivo* by electrical measurement. *J Invest Dermatol* 1980;75(6):500–7.
91. Carlson NR. *Physiology of Behavior*. 11th edn. Boston, MA: Pearson; 2013.
92. Lademann J, Otberg N et al. Application of optical non-invasive methods in skin physiology: Comparison of laser scanning microscopy and optical coherence tomography with histological analysis. *Skin Research and Technology* 2007;13:119–32.
93. Mack Correa MC, Mao G et al. Molecular interactions of plant oil components with stratum corneum lipids correlate with clinical measures of skin barrier function. *Exp Dermatol* 2014;23(1):39–44.
94. Rajadhyaksha M, Gonzalez S et al. In-vivo confocal scanning laser microscopy of human skin II: Advances in instrumentation and comparison with histology. *J Invest Dermatol* 1999;113:293–303.
95. Kucharekova M, Van De Kerkhof PC et al. A randomized comparison of an emollient containing skin-related lipids with a petrolatum-based emollient as adjunct in the treatment of chronic hand dermatitis. *Contact Dermatitis* 2003;48(6):293–9.
96. Welzel J, Wilhelm KP et al. Skin permeability barrier and occlusion: No delay of repair in irritated human skin. *Contact Dermatitis* 1996;35(3):163–8.

Melasma and Depigmentation Agents

Oma N. Agbai and Susan C. Taylor

Introduction

Hyperpigmentation is a common complaint encountered by dermatologists. A study of 2000 dermatology patients with darker skin tones revealed that pigmentary disorders were the third most common diagnosis, preceded only by acne and eczema.¹ Of the disorders of pigmentation, melasma, chloasma, solar lentigines, and post-inflammatory hyperpigmentation were the most common.

Melasma is an acquired pigmentary disorder which typically manifests as hyperpigmented macules and patches symmetrically distributed on the face, neck, and occasionally the upper extremities. The majority of melasma is seen in women of reproductive age and darker skin tones (Fitzpatrick skin types III–IV²). However, individuals of all ages, skin hues, and races may be affected.³ The vast majority of cases of melasma are linked to risk factors which include ultraviolet (UV) radiation and hormones, including the use of oral contraceptives, estrogen replacement therapy, and pregnancy. Additional risk factors reported in the literature are antiepileptic medications, phototoxic medications, thyroid disease, and genetic predisposition.³ Nonetheless, this condition may be idiopathic, especially in men.⁴ Melasma is often chronic, persistent, relapsing, and difficult to treat. Additionally, melasma may significantly affect a patient's quality of life, as demonstrated in studies utilizing the Melasma Quality of Life Scale (MELASQOL).^{5,6} In a prospective cohort study of the effect of pigmentary disorders on quality of life, 47.3% of patients reported feeling somewhat self-conscious about their skin, while 21.8% believed people around them focused on the appearance of their skin. Additionally, 32.7% of those surveyed reported putting special effort into concealing their pigment abnormalities, and 23.6% reported their skin condition affected their daily activities.⁷ The high prevalence of melasma, coupled with the potential negative impact on quality of life, necessitates effective and safe management of this disorder. Cosmeceuticals are now more commonly used to treat disorders of hyperpigmentation, including melasma. This chapter will review the role of cosmeceutical products in the treatment of melasma, including safety and efficacy.

Clinical Presentation

Melasma is an acquired disorder of hyperpigmentation, symmetrically distributed, with light to dark brown macules and patches located most often on the face. The chin, malar regions, and forehead are predominantly affected.² Melasma is also referred to as chloasma, or the mask of pregnancy.² A number of clinical patterns have been described. The centrofacial pattern involves the forehead, cheeks, nose, chin, and/or upper lip; the malar pattern characteristically involves the cheeks and nose. Additionally, the mandibular pattern involves the ramus of the mandible, but has been speculated to be a type of Poikiloderma of Civatte, as affected patients are often post-menopausal and biopsies demonstrate significant actinic damage.⁸ While several clinical patterns have been described, many patients have a combination of patterns.⁹

Histopathologic Findings

A number of recent studies have evaluated the patterns of melasma from a histopathologic perspective. A study⁹ which evaluated biopsy specimens of lesional skin described two distinct histopathologic patterns of melasma: an epidermal form with deposition of melanin primarily in the basal/suprabasal layers, with highly dendritic melanocytes full of pigment; and a dermal type with superficial and deep dermal perivascular melanophages and less prominent epidermal pigmentation.⁹ In this study,⁹ examination by Wood's lamp was shown to be consistent with biopsy results demonstrating histopathologically-proven epidermal pigmentation.⁹ Grimes et al.¹⁰ demonstrated that lesions consistent with epidermal melasma on Wood's lamp evaluation histologically demonstrated increased melanin deposition in both the dermis and the epidermis. Furthermore, this group utilized Mel-5 staining to demonstrate that there was no increase in melanocyte number, but that the melanocytes in the lesional skin were larger in size and had more prominent dendritic processes¹⁰; data supported by electron microscopy. Therefore, melasma lesions that appear to be epidermal may, in actuality, have significant amounts of melanin in the dermis.¹⁰ A comparative study¹¹ of the histopathologic characteristics of melasma versus normal Asian skin demonstrated more severe solar elastosis, increased melanin in all layers of the epidermis, and increased free melanin and melanophages in the dermis. Additionally, melanocytes in melasma lesions had more dendrites, rough endoplasmic reticulum, mitochondria, and Golgi, suggesting that they had increased biological activity compared to similar structures observed in normal skin.¹¹ The consistent demonstration of dermal melanin and melanophages in the aforementioned studies may explain the difficulty sometimes encountered when treating apparently epidermal melasma.¹¹

Risk Factors, Etiology, and Pathogenesis

Although the precise etiology for melasma remains unclear, there are several well-established risk factors. For example, individuals with darker skin tones are at greater risk, as melasma is predominantly seen in Fitzpatrick skin types III and IV. Additional risk factors include exposure to UV light, pregnancy, genetic predisposition, and exogenous hormone therapy (such as oral contraceptives and hormone replacement therapy).¹²

UV light is a widely reported etiologic and exacerbating factor in melasma, given its effects on melanocytes and cytokine production. Melasma lesions are seen in photo-exposed skin and patients typically report exacerbation with sun exposure.² There are multiple potential reasons for this, including the fact that UV radiation has been shown to promote melanocyte proliferation and melanogenesis and migration. Furthermore, UV radiation can stimulate the production of several cytokines, such as interleukin-1, alpha-melanocyte-stimulating hormone (α -MSH), and endothelin-1, which then upregulate melanocyte proliferation and melanogenesis.²

The hormonal impact on melasma development and exacerbation has yet to be consolidated. Many patients report onset or worsening of melasma with oral contraceptive use or pregnancy.¹³ One study¹⁴ evaluated the relationship between circulating hormone levels and their relationship to melasma, and found that nulligravid women with melasma had markedly higher levels of serum LH and lower levels of estradiol than controls. Furthermore, this group found no difference in the levels of additional serum hormones such as ACTH, beta MSH, FSH, progesterone, thyroid hormone, prolactin, or cortisol.¹⁴ Additionally, lesional melasma skin has been shown through immunohistochemical staining to have increased estrogen receptor expression compared to normal skin,¹⁵ and incubation of melanocytes from normal skin with estradiol has been shown to increase melanocyte proliferation, but paradoxically down-regulate melanogenesis and tyrosinase activity.¹⁶ Clearly, the exact relationship between hormones and melasma development and/or exacerbation has yet to be elucidated.

Additional, less commonly reported risk factors for melasma include the expression of stem cell factors,¹⁷ use of phototoxic medications and cosmetics,¹⁸ neural factors,¹⁹ vascular influences,²⁰ and the presence of thyroid disorders.²¹ Further studies are indicated as conclusive data is unavailable.

Differential Diagnosis

Proper diagnosis of melasma is vital to effective treatment. Skin conditions that may mimic the clinical appearance of melasma include postinflammatory hyperpigmentation, drug-induced hyperpigmentation, ephelides, facial acanthosis nigricans, solar lentigines, nevus of Ota, acquired bilateral nevus of Ota-like macules (Hori's nevus), actinic lichen planus, and frictional melanosis.²² Performance of a thorough medical history including examination with a Wood lamp, correct diagnosis of concomitant inflammatory conditions, and, as indicated, skin biopsy, are useful in establishing the correct diagnosis.

Cosmeceutical Options for Melasma Treatment

Patients frequently seek natural alternatives to address skin disorders including melasma in order to prevent potential adverse effects and decrease exposure to perceived harmful chemicals. Cosmeceuticals are perceived as milder but effective options for treatment of melasma. We will review available cosmeceutical treatments of melasma (Table 27.1).

Hydroquinone

Hydroquinone (HQ) is regarded as the gold standard for the treatment of disorders of hyperpigmentation including melasma. It competitively inhibits melanin synthesis through the inhibition of sulfhydryl groups and by acting as a substrate for the enzyme tyrosinase. Semiquinone free radicals are then released, which subsequently damage melanocytes and melanosomes in treated skin.²³ Although HQ is available in concentrations of 2% and 4%, it is the 2% concentration that is commonly available in over-the-counter cosmeceutical products. Clinical studies have reported good to excellent efficacy of HQ 2% in the treatment of disorders of hyperpigmentation.²⁴ While effective, multiple potential acute adverse effects have been reported, including allergic or irritant contact dermatitis and post-inflammatory hyper- and hypopigmentation. Of these, the most common is irritant contact dermatitis.²⁵ Chronic adverse effects of topical HQ are also recognized and include exogenous ochronosis, pigmented colloid milia, nail pigmentation, cataracts, reduction of skin elasticity, development of offensive fish odor, and impaired wound healing.²⁶ The most common of the chronic adverse effects is exogenous ochronosis.²⁶ Ochronosis typically manifests as asymptomatic hyperpigmented macules or patches on sun-exposed skin, specifically the face, upper back, and upper chest. Less common manifestations of ochronosis include asymptomatic erythema, gray-blue colloid milia, and papulonodules on sun-exposed areas.¹² Though various formulations of HQ are used widely in the United States, ochronosis is an uncommon adverse effect. Of note, the majority of reported cases of ochronosis are secondary to the use of 2% HQ.¹² In 2006, the Food and Drug Administration (FDA) propositioned a ban on over-the-counter HQ. These measures were proposed due to the potential for development of ochronosis and carcinogenicity. While some animal studies have demonstrated a heightened rate of cancer development with HQ use,²⁷ no human studies have demonstrated increased cutaneous or internal carcinogenicity with HQ use.

Mequinol

Mequinol is a HQ derivative that has been used as an alternative to HQ. Its mechanism of action has yet to be fully elucidated. It functions as a substrate for tyrosinase, thus inhibiting the formation of melanin precursors.²⁸ Studies have demonstrated mequinol's efficacy in improving hyperpigmented skin lesions when a 2% formulation is combined with 0.01% tretinoin.²⁹ It has been marketed in the United States in the aforementioned formulation with tretinoin, with adverse events including burning, erythema, pruritus, skin irritation, desquamation, and halo hypopigmentation being reported. Using this formulation with sunscreen reduces the incidence and severity of these potential adverse reactions.³⁰

TABLE 27.1

Cosmeceutical Treatments of Hyperpigmentation

Treatment	Mechanism of Action	Strong Data Supporting Efficacy?	Common Side Effects
Hydroquinone	Competitive inhibition of melanin synthesis by inhibiting sulfhydryl groups and acting as a substrate for the enzyme tyrosinase ²³	Yes ²⁴ Good to excellent efficacy of 2% formulation	Allergic or irritant contact dermatitis, exogenous ochronosis ²⁵
Azelaic acid	Reversible inhibition of tyrosinase activity	Yes ^{32,33}	Erythema, pruritus, and scaling ³³
Kojic acid	Inhibition of free tyrosine kinase production ³⁴	Limited ³⁵ 40 Chinese women showed greater improvement with combination of 2% kojic acid gel compounded with 10% glycolic acid and 2% HQ vs. the above without kojic acid	Stinging, erythema, and mild exfoliation (may not be unique to kojic acid)
Retinol	Inhibits tyrosinase transcription, suppresses melanocyte dispersion of pigment granules to keratinocytes, reduces duration of contact between keratinocytes and melanocytes through enhancement of epidermal cell turnover ³⁶	Limited Studied in combination with lactic acid and compared to tretinoin 0.1% and dexamethasone 0.1%—similar results ³⁸	Irritant dermatitis
Ascorbic acid	Reduces melanogenesis through the reduction of <i>o</i> -dopaquinone to dihydroxyphenylalanine (DOPA) ^{12,39}	Limited 5% ascorbic acid and 4% hydroquinone in 16 female patients with melasma reported 62.5% and 93% improvement ⁴⁰	No significant adverse effects ⁴⁰
Alpha tocopherol (vitamin E)	Interference with lipid peroxidation of melanocyte membranes, increase of intracellular glutathione content and tyrosinase inhibition ⁴³	Yes ⁴⁴ Greater efficacy when combined with vitamin C than when used alone	Rare allergic or irritant contact dermatitis ⁴⁴
Niacinamide	Inhibitor of melanosome transfer to epidermal keratinocytes ⁴⁵	Yes ⁴⁵ Clinical trials have studied 2% formulation primarily	Not well established
Lignin peroxidase	Unknown—may depolymerize melanin	Yes Statistically significant benefit over 2% hydroquinone and placebo in one study ⁴⁸	Mild and rare irritation ⁴⁸
Grape seed extract	Unknown	No, though 6 month intake showed benefit in one study ⁵⁰	Not well established
Orchid extract	Unknown	No, though efficacy demonstrated when combined with vitamin C ⁵¹	Not well established
Licorice extract	Dispersion of melanin, inhibition of melanin biosynthesis ⁵³	Limited Studies have demonstrated 70% improvement of pigment intensity with daily liquiritin × 4 weeks ⁵³	Not well established

TABLE 27.1 (Continued)

Cosmeceutical Treatments of Hyperpigmentation

Treatment	Mechanism of Action	Strong Data Supporting Efficacy?	Common Side Effects
Arbutin	Suppresses tyrosinase activity without altering RNA expression; suppresses the maturation of melanocytes ⁵⁴	Yes Synthetic form deoxyarbutin has been shown to yield results similar to that of hydroquinone ⁵⁵	Not well established (Continued)
Aloe vera extract	Dose-dependent melanin aggregation ⁵⁶	No	Rare
Boswellia ⁵⁷	Unknown	No	Not well established
Cinnamic acid	Tyrosinase inhibition	Limited One study demonstrated that cinnamic acid (2 mmol/L; 0.5 mmol/L) showed greater tyrosinase inhibition when compared to hydroquinone (0.5 mmol/L) ⁵⁸	Not well established
Marine algae extract	Tyrosinase inhibition	Limited One study showed similar function to kojic acid ⁵⁹	Not well established
Soy	Suppresses PAR-2 activation, and subsequently inhibit melanosome transfer, ⁶⁰ inhibit melanogenesis ⁶¹	Yes ⁶² Lightening of mottled pigmentation shown after 12 weeks in study of 65 women	Rare
Flavonoids	Unknown	No	Not well established
Green tea extracts	Unclear, though suppression of mushroom tyrosinase was shown in one study ⁶³	No	Not well established
Coffeeberry	Unknown	Limited 30 subjects showed improvement after 6 weeks ⁶⁴	Not well established
Pycnogenol	Unknown	No Oral agent shown to lighten melasma lesions, limited studies on topical agent ⁶⁵	Not well established
<i>N</i> -acetyl glucosamine (NAG)	Inhibits glycosylation of tyrosinase, reduces the amount of melanin in melanocytes ⁶⁸	Limited 2% NAG caused improvement after 8 weeks ⁶⁸ , greater efficacy when combined with niacinamide ⁶⁹	Not well established

N-Acetyl-4-S-Cysteaminylphenol (NCAP)

NCAP is a phenolic compound that suppresses tyrosinase activity by acting as an alternative substrate. It has been shown to be less irritating and more stable than HQ. Clinical studies employing 4% NCAP have demonstrated significant improvement in patients with melasma, with clinical response apparent after two to four weeks of treatment.³¹

Azelaic Acid

A naturally found dicarboxylic acid, azelaic acid is obtained from cultures of *Pityrosporum ovale*. *In vitro* studies have demonstrated potential interference with DNA synthesis, in addition to reversible inhibition of tyrosinase activity. While azelaic acid demonstrates cytotoxic and antiproliferative activity on abnormal melanocytes, it does not affect normal melanocytes. Efficacy of 15%–20% concentrations of azelaic acid has been shown to be equivalent to HQ 4% in the treatment of melasma and post inflammatory hyperpigmentation.³² Combinations of azelaic acid with tretinoin 0.05% and glycolic acid 15%–20% lead to enhanced efficacy.³³ Potential adverse effects included transient erythema, pruritus, and scaling.³³

Kojic Acid

Kojic acid (5-hydroxy-2-hydroxymethyl-4-pyrone) is a hydrophilic fungal derivative acquired from *Acetobacter*, *Penicillium*, and *Aspergillus* species, which reduces pigmentation through the inhibition of free tyrosine kinase production. Additionally, it is a potent antioxidant.³⁴ Kojic acid is often utilized as a component of cosmeceutical formulations in Asia and the United States at concentrations ranging from 1% to 4%. There are no randomized controlled trials comparing the efficacy of kojic acid to other cosmeceuticals. However, given that kojic acid and HQ both function through inhibition of tyrosinase, combining the two may result in augmentation of efficacy. This was demonstrated in one study³⁵ in which 40 Chinese women with epidermal melasma were treated with 2% kojic acid gel compounded with 10% glycolic acid and 2% HQ on the active side of the face. The other control side of the face was treated with the same combination without kojic acid. While visible improvement was noted on both sides of the face, 60% of lesions treated with kojic acid versus 47.5% of those in the control group showed over 50% improvement of melasma. Given these results, the addition of kojic acid may be beneficial in patients who do not respond to HQ alone.³⁵ Adverse effects reported in this study were observed regardless of kojic acid use, and included stinging, erythema, and mild exfoliation.³⁵

Retinoids

Retinoids are comprised of synthetic and natural derivatives of vitamin A that may be found both in prescription medications and over-the-counter cosmeceuticals. Tretinoins (all-*trans*-retinoic acid), in addition to synthetic naphthalene derivatives such as tazarotene, bexarotene, and adapalene, are registered prescription retinoids. The prescription topical retinoids have been studied extensively and are indicated for photoaging, acne, and pigmentary disorders. However, these formulations may be irritating and produce a retinoid dermatitis which limits their use in some patients. Topical cosmeceutical retinoids, such as retinaldehyde (RAL), and retinol (ROL), are of particular interest as gentler yet effective alternatives to their prescription counterparts. Topical retinoids decrease hyperpigmentation through multiple mechanisms. One mechanism involves inhibition of tyrosinase transcription, which suppresses melanogenesis. Additionally, retinoids suppress the dispersion of pigment granules from melanocytes into keratinocytes. Furthermore, retinoids reduce the duration of contact between keratinocytes and melanocytes through enhancement of epidermal cell turnover which, in turn, promotes pigment loss through

epidermopoiesis.³⁶ While prescription topical retinoids have been extensively studied, there are very few clinical studies on topical cosmeceutical retinoids such as ROL or RAL. In one clinical trial, retinol 10% and lactic acid 7% were used in place of tretinoin 0.1% and dexamethasone 0.1% (a formula established by Kligman and Willis³⁷). The new formulation with retinol and lactic acid was shown to be comparable to that of Kligman and Willis, and had the advantage of preventing steroid-induced cutaneous atrophy.³⁸ While the degree of hypopigmentation was comparable to that of tretinoin, ROL also induced irritant dermatitis,³⁸ as can be seen with tretinoin use.

Ascorbic Acid

Ascorbic acid is an antioxidant which facilitates pigment reduction through multiple modalities. It reduces melanogenesis through the reduction of *o*-dopaquinone to dihydroxyphenylalanine (DOPA) and it alters the appearance of melanin from black to light tan. Ascorbic acid is very unstable and quickly oxidized in aqueous solutions. Synthetic ascorbate esters, such as magnesium ascorbyl-2-phosphate, have been engineered to prevent oxidation.³⁹ Ascorbic acid is frequently combined with HQ in cosmeceutical skin-lightening formulations. These types of combination products are usually well-tolerated in all skin types.¹²

One study comparing 5% ascorbic acid and 4% HQ in 16 female patients with melasma reported 62.5% and 93% improvement, respectively. Adverse reactions were noted in 68.7% of the HQ group compared to 6.2% of the ascorbic acid group. While HQ yielded higher efficacy, ascorbic acid remains a potential treatment option given its lack of significant adverse effects and ability to be used alone or in combination therapy.⁴⁰

Alpha Tocopherol (Vitamin E)

The term “vitamin E” actually encompasses eight naturally occurring molecules (four tocopherols and four tocotrienols) that have vitamin E activity. In humans, alpha tocopherol is the most abundant derivative, followed by gamma tocopherol.⁴¹ There are several studies⁴² demonstrating its photo-protective effects. Additionally, vitamin E has been shown to lighten skin through multiple modalities, including interference with lipid peroxidation of melanocyte membranes, increase of intracellular glutathione content, and tyrosinase inhibition.⁴³ One study demonstrated marked improvement of melasma and pigmented contact dermatitis lesions using combined vitamin E and C topically. The combination showed greater efficacy when compared to the single-vitamin treatment groups.⁴⁴ Though topical alpha-tocopherol is typically used at concentrations lower than 5%, products with various concentrations are marketed. Potential adverse effects such as allergic or irritant reactions are rare with topical vitamin E use, making it a popular choice for cosmeceutical formulations.

Niacinamide

Niacinamide, also known as nicotinamide (3-pyridine-carboxamide), is the physiologically-active form of niacin (vitamin B3). Niacin is a precursor to NADH and NADPH. It functions as an inhibitor of melanosome transfer to epidermal keratinocytes. One study performed on pigmented reconstructed epidermis (PREP) demonstrated that niacinamide interferes with melanocyte/keratinocyte interaction, thus reducing melanogenesis. Furthermore, it has been shown to modulate protease-activated receptor (PAR-2), which is involved in melanosome transfer from melanocytes to surrounding keratinocytes.⁴⁵ Clinical trials employing 2% niacinamide have demonstrated a significant reduction in the area of hyperpigmentation following four weeks of treatment. A plateau in treatment effect was noted, which may be attributable to the balance between the promotion of melanogenesis in hyperpigmented skin and down-regulation of melanogenesis by niacinamide. Alternatively, this plateau may represent the fraction of the hyperpigmented skin which is susceptible to melanogenesis reduction induced by niacinamide.⁴⁵

Additionally, when combined with sunscreen daily, niacinamide use was shown to reduce hyperpigmentation and promote lightness of basal skin color when compared with sunscreen alone.⁴⁵ Niacinamide has also been shown to reduce photodamage in Asian patients, with a study of a 5% niacinamide moisturizer yielding a notable improvement in facial hyperpigmentation in this group.⁴⁵ There are now several over-the-counter cosmeceuticals containing niacinamide, often combined with sunscreen and/or vitamin C.⁴⁶

Lignin Peroxidase

Lignin peroxidase is a naturally-occurring enzyme derived from the tree fungus *Phanerochaete chrysosporium*. It is the enzyme that facilitates the decolorization of decaying trees.⁴⁷ The molecular structure of lignin resembles that of melanin, and studies have demonstrated that lignin peroxidase may also depolymerize melanin. However, the exact mechanism of skin lightening by lignin peroxidase has yet to be elucidated. One clinical study⁴⁸ compared lignin peroxidase (LIP) creams applied twice daily to twice-daily application of 2% HQ cream and placebo in 51 Asian women with hyperpigmentation. A statistically significant improvement from baseline was observed in LIP-treated lesions by day 31 of therapy. HQ and placebo did not yield statistically significant lightening effects. Clinical improvement in the LIP-treated group was seen as early as eight days after treatment was initiated, markedly earlier than that of the HQ and placebo groups.⁴⁸ A subset of patients experienced mild irritation, but there was no statistically significant difference between the treatment groups.⁴⁸ Lignin peroxidase is produced in a liquid form in Switzerland.

Botanical Agents

Many botanical agents that have an impact on melanin and melanocytes have been identified. An *in vitro* study of 101 plant extracts which evaluated their effect on melanin synthesis in B16 melanoma cells⁴⁹ identified *Broussonetia kazwoki*, *B. papyrifera*, *Rhus javanica*, *Pinus densiflora*, and *Cornus officinalis* as having an inhibitory effect on tyrosinase and DOPA oxidation in a dose-dependent manner. Given the low incidence of adverse effects, a number of plant extracts are being included in various cosmeceuticals. The botanical extracts employed for treatment of hyperpigmentation discussed below include grape seed extract, orchid extract, licorice extract, arbutin, aloe vera, botswillia, cinnamic acid, marine algae, soy, flavonoids, green tea extract, coffeeberry, pycnogenol, and mulberry extract.

Grape Seed Extract

Grape seed extract is comprised of proanthocyanidin, a potent antioxidant. While there are no randomized controlled trials on the topical use of grape seed extract, oral intake for six months has been shown to be beneficial in patients with melasma in one study.⁵⁰

Orchid Extract

A study comparing the skin-lightening efficacy of a cosmetic formulation using orchid extract to 3% vitamin C in 48 female patients with melasma and lentiginosities revealed similar efficacy of orchid acid extract to topical vitamin C.⁵¹

Licorice Extract

Licorice extract is one of the most commonly employed ingredients in cosmetics for skin lightening.²⁸ It is obtained from the root of *Glycyrrhiza glabra* Linnæa. Active ingredients in licorice extract include liquiritin, glabridin, and licochalcone A. Licorice extract improves hyperpigmentation through dispersion of melanin, inhibition of melanin biosynthesis, and inhibition of cyclooxygenase activity, which in turn decreases free radical production. Glabridin is the main component of licorice extract; it is a polyphenolic flavonoid, which has been shown to prevent ultraviolet B (UVB)-induced pigmentation.

Furthermore, glabridin enacts anti-inflammatory effects through inhibition of superoxide anion and cyclooxygenase activity.⁵² Liquiritin, another component of licorice extract, has been shown to be efficacious in lightening melasma lesions. In a study of 20 subjects with melasma, one gram of liquiritin cream was applied daily for four weeks, with results ranging from satisfactory to excellent and an objective reduction in pigment intensity in 70% of patients treated with liquiritin.⁵³ However, additional studies are indicated to further substantiate the hypopigmenting action of licorice extract and its components.

Arbutin

Arbutin is a β -D-glucopyranoside HQ derivative and a plant-derived compound found in the dried leaves of several plant species, including blueberry, cranberry, bearberry, and pear trees. It suppresses tyrosinase activity without altering RNA expression. Furthermore, arbutin suppresses the maturation of melanocytes.⁵⁴ Arbutin activity is concentration-dependent with higher concentrations exhibiting higher efficacy, but potentially causing paradoxical hyperpigmentation.⁵⁴ Arbutin has been included in various pigment reducing products in Japan, usually at 3% concentrations. There is a synthetic formulation, deoxyarbutin, which enacts greater tyrosinase inhibition than the naturally occurring form.²⁸ Additionally, arbutin is used in various cosmeceutical skin-lightening formulations in the United States.

Several studies have shown that arbutin is not as effective as kojic acid in improving hyperpigmentation. Deoxyarbutin, the synthesized topical derivative, has been shown to yield enhanced sustained improvement in skin lightening and a safety profile similar to that of HQ.⁵⁵

Aloe Vera Extract

One study performed on animals demonstrated that the leaf extract of aloe vera and its active ingredient aloin promoted significant, dose-dependent melanin aggregation, resulting in skin-lightening through andrenergic receptor stimulation.⁵⁶ Aloe vera is incorporated into numerous cosmeceutical formulations.

Boswellia

Boswellias (BAs) are penacyclic triterpenes, with significant anti-inflammatory functionality. They are extracted from the gum resins of the tropical tree *Boswellia serrate*, which grows in Africa and India. In several clinical trials and *in vitro* and *in vivo* studies, boswellic acids were shown to have pronounced pro-apoptotic and anti-inflammatory activity.⁵⁷ Although boswellias are included in many cosmetic formulations, the mechanism of hypopigmentation has yet to be elucidated.

Cinnamic Acid

Cinnamic acid is a phenyl propanoid derivative found in plants. It functions through inhibition of tyrosinase activity, which has been demonstrated in studies performed on human and guinea pig melanocytes. One study demonstrated that cinnamic acid (2 mmol/L; 0.5 mmol/L) showed greater tyrosinase inhibition when compared to HQ (0.5 mmol/L).⁵⁸

Marine Algae Extract

A study examined the efficacy of 43 marine algae extracts on melanin synthesis and found that some extracts exhibited potent tyrosinase inhibitory function similar to that of positive control, kojic acid, without inducing any adverse effects.⁵⁹ Therefore, these extracts may potentially be effective in cosmeceuticals designed for skin-lightening.

Soy

Soy is primarily comprised of phospholipids (45%–60%) and essential fatty oils (30%–35%). It also contains active ingredients such as isoflavones, vitamin E, and serine protease inhibitors including

soybean trypsin inhibitor (STI) and Bowman–Birk protease inhibitor (BBI). Multiple components of soy function to reduce hyperpigmentation. Protease inhibitors suppress PAR-2 activation and subsequently inhibit melanosome transfer.⁶⁰ Additionally, the fatty acids in soy inhibit trypsin, a known activator of PAR-2.⁶¹ The safety and efficacy of soy has been demonstrated in clinical studies. In a study of 65 women, effective lightening of mottled pigmentation was achieved after using a soy formulation for 12 weeks.⁶² Various cosmeceutical products containing soy are available to improve hyperpigmentation.

Flavonoids

Flavonoids are naturally-occurring polyphenolic compounds with antioxidant, anti-inflammatory, anti-carcinogenic, and antiviral properties. A number of plant-derived flavonoids are still under investigation, including catechin conjugated with gallic acid (from green tea leaves), aloein (from the aloe tree), and ellagic acid (from green tea, strawberry, eucalyptus, etc.).

Green Tea Extract

Green tea extracts contain polyphenolic compounds which act on a number of biochemical pathways, therefore yielding anti-oxidant, anti-inflammatory, and anti-carcinogenic effects. Epigallocatechin-3-gallate is the primary active ingredient in the green tea. A study demonstrated that green tea extracts suppress mushroom tyrosinase, which may be responsible for the skin-lightening effect.⁶³ Still, more studies are indicated to substantiate this data.

Coffe berry

Coffee extract has well-known anti-oxidant properties. Still, its skin-lightening efficacy has yet to be substantiated through randomized controlled clinical studies. Thirty subjects with hyperpigmentation secondary to photodamage showed clinical improvement of the hyperpigmented lesions after six weeks of topical coffe berry extract use.⁶⁴

Pycnogenol

Pycnogenol is extracted from the bark of French maritime pine *Pinus pinaster*, and has gained interest as a cosmeceutical for skin lightening purposes. It is comprised of procyanidins, polyphenolic monomers, and phenolic or cinnamic acids. Anti-inflammatory and antioxidant functionality has been demonstrated, therefore it acts as a free radical scavenger. Pine extract has been included in a variety of cosmeceutical formulations. Oral pycnogenol has been shown to lighten melasma lesions, though studies on its topical use are limited.⁶⁵

N-Acetyl Glucosamine

N-acetyl glucosamine (NAG) is a newer pigment reduction agent. It is an amino-monosaccharide produced in the body by adding an amino group to glucose.⁶⁶ It has multiple functions in the body, including acting as a substrate for hyaluronic acid, proteoglycan, and heparin sulphite production. Additionally, *N*-acetyl glucosamine helps to maintain proper dermal water balance. Regarding its functionality as a pigment-lightening agent, *N*-Acetyl glucosamine inhibits glycosylation of tyrosinase, which is required for melanin production.⁶⁷ Furthermore, NAG reduces the amount of melanin in melanocytes, therefore lightening hyperpigmented skin. In one study, 2% NAG was shown to improve facial hyperpigmentation after eight weeks of application.⁶⁸ Combining NAG with niacinamide has been shown to have greater efficacy in improving hyperpigmented skin in clinical studies.⁶⁹ *N*-acetyl glucosamine comprises a number of cosmeceuticals for skin lightening.

Mulberry Extract

Mulberry extract is a derivative from the plant *Morus alba* L. from the Moraceae family. The leaves of the plant exhibit anti-hyperglycemic activity, and the derivatives from its root bark have been demonstrated to have a skin-lightening effect. A possible mechanism involves inhibition of DOPA oxidase activity of tyrosinase, in addition to superoxide scavenging activity. IC₅₀ (the concentration causing 50% inhibition of tyrosinase activity) is low (0.396%) when compared to 5.5% for HQ and 10.0% for kojic acid.⁷⁰ Further studies are indicated to substantiate the safety and efficacy of mulberry extract in skin lightening.

Conclusion

Melasma is a potentially disfiguring disorder which has a negative impact on the quality of life. There are many effective cosmeceutical ingredients for the treatment of melasma. While there are several treatment modalities for melasma, photoprotective measures with daily use of SPF 30 broad spectrum sunscreens, sun-protective clothing, and photo-avoidance are vital to achieve successful outcomes in melasma treatment.

REFERENCES

1. Halder RM, Grimes PE, McLaurin CI et al. Incidence of common dermatoses in a predominantly black dermatologic practice. *Cutis* 1983;32:388–90.
2. Sheth VM, Pandya AG. Melasma: A comprehensive update: Part I. *J Am Acad Dermatol* 2011;65:689–97; quiz 98.
3. Kauh YC, Zachian TF. Melasma. *Adv Exp Med Biol* 1999;455:491–9.
4. Vazquez M, Maldonado H, Benmaman C et al. Melasma in men. A clinical and histologic study. *Int J Dermatol* 1988;27:25–7.
5. Freitag FM, Cestari TF, Leopoldo LR et al. Effect of melasma on quality of life in a sample of women living in southern Brazil. *J Eur Acad Dermatol Venereol* 2008;22:655–62.
6. Pandya A, Berneburg M, Ortonne JP et al. Guidelines for clinical trials in melasma. Pigmentation disorders academy. *Br J Dermatol* 2006;156(Suppl 1):21–8.
7. Taylor A, Pawaskar M, Taylor SL et al. Prevalence of pigmentary disorders and their impact on quality of life: A prospective cohort study. *J Cosmet Dermatol* 2008;7:164–8.
8. Mandry Pagan R, Sanchez JL. Mandibular melasma. *P R Health Sci J* 2000;19:231–4.
9. Sanchez NP, Pathak MA, Sato S et al. Melasma: A clinical, light microscopic, ultrastructural, and immunofluorescence study. *J Am Acad Dermatol* 1981;4:698–710.
10. Grimes PE, Yamada N, Bhawan J. Light microscopic, immunohistochemical, and ultrastructural alterations in patients with melasma. *Am J Dermatopathol* 2005;27:96–101.
11. Kang WH, Yoon KH, Lee ES et al. Melasma: Histopathological characteristics in 56 Korean patients. *Br J Dermatol* 2002;146:228–37.
12. Grimes PE. Melasma. Etiologic and therapeutic considerations. *Arch Dermatol* 1995;131:1453–7.
13. Resnik S. Melasma induced by oral contraceptive drugs. *JAMA* 1967;199:601–5.
14. Perez M, Sanchez JL, Aguilo F. Endocrinologic profile of patients with idiopathic melasma. *J Invest Dermatol* 1983;81:543–5.
15. Lieberman R, Moy L. Estrogen receptor expression in melasma: Results from facial skin of affected patients. *J Drugs Dermatol* 2008;7:463–5.
16. Jee SH, Lee SY, Chiu HC et al. Effects of estrogen and estrogen receptor in normal human melanocytes. *Biochem Biophys Res Commun* 1994;199:1407–12.
17. Kang HY, Hwang JS, Lee JY et al. The dermal stem cell factor and c-kit are overexpressed in melasma. *Br J Dermatol* 2006;154:1094–9.
18. Sheth VM, Pandya AG. Melasma: A comprehensive update: Part II. *J Am Acad Dermatol* 2011;65:699–714; quiz 5.

19. Bak H, Lee HJ, Chang SE et al. Increased expression of nerve growth factor receptor and neural endopeptidase in the lesional skin of melasma. *Dermatol Surg* 2009;35:1244–50.
20. Kim EH, Kim YC, Lee ES et al. The vascular characteristics of melasma. *J Dermatol Sci* 2007;46:111–6.
21. Lutfi RJ, Fridmanis M, Misiunas AL et al. Association of melasma with thyroid autoimmunity and other thyroidal abnormalities and their relationship to the origin of the melasma. *J Clin Endocrinol Metab* 1985;61:28–31.
22. Trout CRLN, Chang MW. *Disorders of Hyperpigmentation*. New York, NY: Mosby Elsevier; 2003.
23. Denton CR, Lerner AB, Fitzpatrick TB. Inhibition of melanin formation by chemical agents. *J Invest Dermatol* 1952;18:119–35.
24. Spencer MC. Topical use of hydroquinone for depigmentation. *JAMA* 1965;194:962–4.
25. Bentley-Phillips B, Bayles MA. Cutaneous reactions to topical application of hydroquinone. Results of a 6-year investigation. *S Afr Med J* 1975;49:1391–5.
26. Nordlund J, Grimes P, Ortonne JP. The safety of hydroquinone. *J Cosmet Dermatol* 2006;5:168–9.
27. Kari FW, Bucher J, Eustis SL et al. Toxicity and carcinogenicity of hydroquinone in F344/N rats and B6C3F1 mice. *Food Chem Toxicol* 1992;30:737–47.
28. Draelos ZD. Skin lightening preparations and the hydroquinone controversy. *Dermatol Ther* 2007;20:308–13.
29. Fleischer AB Jr., Schwartzel EH, Colby SI et al. The combination of 2% 4-hydroxyanisole (Mequinol) and 0.01% tretinoin is effective in improving the appearance of solar lentigines and related hyperpigmented lesions in two double-blind multicenter clinical studies. *J Am Acad Dermatol* 2000;42:459–67.
30. Colby SI, Schwartzel EH, Huber FJ et al. A promising new treatment for solar lentigines. *J Drugs Dermatol* 2003;2:147–52.
31. Jimbow K. N-acetyl-4-S-cysteaminylphenol as a new type of depigmenting agent for the melanoderma of patients with melasma. *Arch Dermatol* 1991;127:1528–34.
32. Nguyen QH, Bui TP. Azelaic acid: Pharmacokinetic and pharmacodynamic properties and its therapeutic role in hyperpigmentary disorders and acne. *Int J Dermatol* 1995;34:75–84.
33. Kakita LS, Lowe NJ. Azelaic acid and glycolic acid combination therapy for facial hyperpigmentation in darker-skinned patients: A clinical comparison with hydroquinone. *Clin Ther* 1998;20:960–70.
34. Kahn V. Effect of kojic acid on the oxidation of DL-DOPA, norepinephrine, and dopamine by mushroom tyrosinase. *Pigment Cell Res* 1995;8:234–40.
35. Lim JT. Treatment of melasma using kojic acid in a gel containing hydroquinone and glycolic acid. *Dermatol Surg* 1999;25:282–4.
36. Ortonne JP. Retinoic acid and pigment cells: A review of in-vitro and in-vivo studies. *Br J Dermatol* 1992;127(Suppl 41):43–7.
37. Kligman AM, Willis I. A new formula for depigmenting human skin. *Arch Dermatol* 1975 Jan;111(1):40–8.
38. Yoshimura K, Momosawa A, Aiba E et al. Clinical trial of bleaching treatment with 10% all-trans retinol gel. *Dermatol Surg* 2003;29:155–60, discussion 60.
39. Kameyama K, Sakai C, Kondoh S et al. Inhibitory effect of magnesium L-ascorbyl-2-phosphate (VC-PMG) on melanogenesis *in vitro* and *in vivo*. *J Am Acad Dermatol* 1996;34:29–33.
40. Espinal-Perez LE, Moncada B, Castaneda-Cazares JP. A double-blind randomized trial of 5% ascorbic acid vs. 4% hydroquinone in melasma. *Int J Dermatol* 2004;43:604–7.
41. Thiele JJ, Hsieh SN, Ekanayake-Mudiyanselage S. Vitamin E: Critical review of its current use in cosmetic and clinical dermatology. *Dermatol Surg* 2005;31:805–13, discussion 13.
42. Darr D, Dunston S, Faust H et al. Effectiveness of antioxidants (vitamin C and E) with and without sunscreens as topical photoprotectants. *Acta Derm Venereol* 1996;76:264–8.
43. Badreshia-Bansal S, Draelos ZD. Insight into skin lightening cosmeceuticals for women of color. *J Drugs Dermatol* 2007;6:32–9.
44. Hayakawa R, Ueda H, Nozaki T et al. Effects of combination treatment with vitamins E and C on chloasma and pigmented contact dermatitis. A double blind controlled clinical trial. *Acta Vitaminol Enzymol* 1981;3:31–8.
45. Hakozaki T, Minwalla L, Zhuang J et al. The effect of niacinamide on reducing cutaneous pigmentation and suppression of melanosome transfer. *Br J Dermatol* 2002;147:20–31.
46. Sarkar R, Arora P, Garg KV. Cosmeceuticals for hyperpigmentation: What is available? *J Cutan Aesthet Surg* 2013;6:4–11.

47. Nagasaki K, Kumazawa M, Murakami S et al. Purification, characterization, and gene cloning of *Ceriporiopsis* sp. strain MD-1 peroxidases that decolorize human hair melanin. *Appl Environ Microbiol* 2008;74:5106–12.
48. Mauricio T, Karmon Y, Khaiat A. A randomized and placebo-controlled study to compare the skin-lightening efficacy and safety of lignin peroxidase cream vs. 2% hydroquinone cream. *J Cosmet Dermatol* 2011;10:253–9.
49. Hwang JH, Lee BM. Inhibitory effects of plant extracts on tyrosinase, L-DOPA oxidation, and melanin synthesis. *J Toxicol Environ Health A* 2007;70:393–407.
50. Yamakoshi J, Sano A, Tokutake S et al. Oral intake of proanthocyanidin-rich extract from grape seeds improves chloasma. *Phytother Res* 2004;18:895–9.
51. Tadokoro T, Bonte F, Archambault JC et al. Whitening efficacy of plant extracts including orchid extracts on Japanese female skin with melasma and lentigo senilis. *J Dermatol* 2010;37:522–30.
52. Yokota T, Nishio H, Kubota Y et al. The inhibitory effect of glabridin from licorice extracts on melanogenesis and inflammation. *Pigment Cell Res* 1998;11:355–61.
53. Amer M, Metwalli M. Topical liquiritin improves melasma. *Int J Dermatol* 2000;39:299–301.
54. Maeda K, Fukuda M, Arbutin: Mechanism of its depigmenting action in human melanocyte culture. *J Pharmacol Exp Ther* 1996;276:765–9.
55. Boissy RE, Visscher M, DeLong MA. Deoxyarbutin: A novel reversible tyrosinase inhibitor with effective *in vivo* skin lightening potency. *Exp Dermatol* 2005;14:601–8.
56. Ali SA, Galgut JM, Choudhary RK. On the novel action of melanolysis by a leaf extract of Aloe vera and its active ingredient aloin, potent skin depigmenting agents. *Planta Med* 2012;78:767–71.
57. Moussaieff A, Mechoulam R. Boswellia resin: From religious ceremonies to medical uses; a review of *in-vitro*, *in-vivo* and clinical trials. *J Pharm Pharmacol* 2009;61:1281–93.
58. Tan C, Zhu W, Lu Y. Aloin, cinnamic acid and sophorcarpidine are potent inhibitors of tyrosinase. *Chin Med J (Engl)* 2002;115:1859–62.
59. Cha SH, Ko SC, Kim D et al. Screening of marine algae for potential tyrosinase inhibitor: Those inhibitors reduced tyrosinase activity and melanin synthesis in zebrafish. *J Dermatol* 2011;38:354–63.
60. Paine C, Sharlow E, Liebel F et al. An alternative approach to depigmentation by soybean extracts via inhibition of the PAR-2 pathway. *J Invest Dermatol* 2001;116:587–95.
61. Leyden J, Wallo W. The mechanism of action and clinical benefits of soy for the treatment of hyperpigmentation. *Int J Dermatol* 2011;50:470–7.
62. Wallo W, Nebus J, Leyden JJ. Efficacy of a soy moisturizer in photoaging: A double-blind, vehicle-controlled, 12-week study. *J Drugs Dermatol* 2007;6:917–22.
63. No JK, Soung DY, Kim YJ et al. Inhibition of tyrosinase by green tea components. *Life Sci* 1999;65:PL241–6.
64. McDaniel DH. Clinical safety and efficacy in photoaged skin with coffeeberry extract, a natural antioxidant. *Cosmet Dermatol*. 2009;22:610–6.
65. Ni Z, Mu Y, Gulati O. Treatment of melasma with Pycnogenol. *Phytother Res* 2002;16:567–71.
66. Bissett DL. Glucosamine: An ingredient with skin and other benefits. *J Cosmet Dermatol* 2006;5:309–15.
67. Bissett D, McPhail S, Farmer T et al. Topical N-acetyl glucosamine affects pigmentation relevant genes in *in vitro* genomics testing. *Pig Cell Res* 2006;19:373.
68. Bissett DL, Robinson LR, Raleigh PS et al. Reduction in the appearance of facial hyperpigmentation by topical N-acetyl glucosamine. *J Cosmet Dermatol* 2007;6:20–6.
69. Kimball AB, Kaczvinsky JR, Li J et al. Reduction in the appearance of facial hyperpigmentation after use of moisturizers with a combination of topical niacinamide and N-acetyl glucosamine: Results of a randomized, double-blind, vehicle-controlled trial. *Br J Dermatol* 2010;162:435–41.
70. Lee SH, Choi SY, Kim H et al. Mulberroside F isolated from the leaves of *Morus alba* inhibits melanin biosynthesis. *Biol Pharm Bull* 2002;25:1045–8.

The Use of Cosmeceuticals for Oily Skin, Seborrhea, and Seborrheic Dermatitis

Negar Foolad, Chelsea Ma, and Raja K. Sivamani

Introduction

Seborrheic dermatitis is a common inflammatory skin condition of unclear etiology that affects approximately 1%–3% of the general U.S. population.^{1,2} It has a bimodal distribution, with peak incidences occurring during infancy and then later in adulthood. Oily skin, or seborrhea, is a condition caused by excessive sebum production that commonly begins in the prepubescent years. It is often, but not always, seen concurrently with seborrheic dermatitis.

Clinical Presentation

Seborrheic Dermatitis

Seborrheic dermatitis is typically characterized by erythematous papules and plaques with fine greasy, yellow scales. It is distributed in areas rich in sebaceous glands, most commonly the scalp, face (hairline, eyebrows, and nasolabial folds), external ears, anterior chest, and intertriginous areas. The condition often follows a chronic relapsing course, and is exacerbated by cold weather.

Oily Skin

Oily skin is a dermatological condition characterized by large pores and a shiny appearance secondary to excessive sebum production. As with seborrheic dermatitis, areas most commonly affected have a higher density of sebaceous glands. The condition is a common cosmetic concern, and patients often complain of a greasy sensation.³

Risk Factors, Etiology, and Pathogenesis

The pathogenesis of seborrheic dermatitis is poorly understood. However, evidence appears to suggest that patients with the condition have an abnormal immune response to *Malassezia*, a fungus that is a normal colonizer of human skin, or its metabolites.^{4–6} Patients with seborrheic dermatitis do not necessarily have a higher concentration of *Malassezia* in their skin, and fungus concentration does not correlate with the severity of the disease.^{5,7} While most individuals with seborrheic dermatitis are healthy, patients with human immunodeficiency virus (HIV) and Parkinsonism are at increased risk.^{8–11}

Differential Diagnosis

The differential diagnosis of seborrheic dermatitis is broad and includes psoriasis, rosacea, pityriasis rosea, tinea versicolor, and tinea corporis. These may often be distinguished clinically.

Cosmeceutical Options for Oily Skin and Seborrheic Dermatitis (Table 28.1)

In Vitro Studies

The essential oil of *Melaleuca alternifolia*, or tea tree oil, has been used for medicinal purposes for about 70 years.¹² These include fungal, bacterial, and viral infections of the skin and mucous membranes of the mouth, as well as wound infections.¹³ Additionally, tea tree oil has been used for mild forms of seborrheic dermatitis, such as dandruff. There are very few clinical studies that attest the medicinal effects of tea tree oil. The antifungal activity was assessed *in vitro* for 22 various *Malassezia furfur* strains, 54 yeasts, and 26 strains of different dermatophyte species. At higher concentrations of the agent, the *M. furfur* strains, yeasts, and dermatophytes were susceptible to tea tree oil. These studies suggest that tea tree oil has antifungal activity.¹³

A study by Pandey et al. evaluated the antimicrobial property of *Cladia aggregate* (Swartz) Nyl., a fruticose lichen from northeastern Himalaya.¹⁴ Study findings suggested that this lichen had anti-*Malassezia* properties, and may be useful as an herbal cosmeceutical for treating seborrheic dermatitis.

In an *in vitro* study, the growth of *Malassezia ovalis* was measured after changing pH, adding sodium chloride (NaCl), and introducing cinnamic acid.¹⁵ A pH of 4.5 and 3.0 resulted in a growth inhibition of 95% and 99.5%, respectively. One molar concentration of NaCl resulted in a decrease in cell growth by greater than 90%. Cinnamic acid had an inhibitory effect at 0.005 g/dL with a 50% reduction of mycotic growth. Other related compounds such as *o*-coumaric acid reduced cell growth by 90%. A recommended cosmetic strategy for scalp seborrheic dermatitis includes treatment with a buffered acidic lotion and shampoo at pH 4.5 followed by topical cinnamic acid.¹⁵

Ilex paraguariensis St. Hilaire is a tree that grows in Paraguay, Brazil, and Argentina.¹⁶ This plant has been used as a medicine for various ailments such as arthritis, hypertension, headache, and slow digestion.¹⁷ The growth of *M. furfur* was evaluated by the addition of an aqueous extract of *I. paraguariensis*. Nine days after treatment, *I. paraguariensis* inhibited the activity of *M. furfur* at 1000 mg/mL. This was similar to the activity of ketoconazole and corresponded to 2.7 µg/mL of ketoconazole, a common treatment for seborrheic dermatitis. Based on study outcomes, the use of topical *I. paraguariensis* was suggested as a therapeutic agent for the prevention and treatment of seborrheic dermatitis.¹⁶

The antibacterial, antimycotic, and anti-inflammatory properties of *Monarda fistulosa* essential oil (MEO) and lavender essential oil (LEO) were evaluated in test cultures.¹⁸ MEO was also studied in mice. The following strains were studied for antibacterial effects: *Staphylococcus aureus* strain ATCC 25923, *Pseudomonas aeruginosa* strain 27853, *Escherichia coli* strain ATCC 25922, *Proteus vulgaris* strain “H” 4636, and *Penicillium* strain 187. MEO had a greater inhibitory effect on microorganism growth compared to that of LEO. Mice studies indicated that MEO had similar anti-inflammatory effects to hydrocortisone-vitamin B₆ combination. Experimental outcomes suggest antibacterial, antimycotic, and anti-inflammatory effects associated with MEO.¹⁸

In vitro studies are important in assessing potential activity, but clinical studies are necessary to assess their true efficacy. Therefore, clinical studies are necessary to further investigate promising *in vitro* studies. The following subsections outline clinical studies for oily skin and seborrheic dermatitis.

Clinical Studies

Agents Studied for Oily Skin

A plant native to Southeast Asia, *Orthosiphon stamineus* is used in traditional herbal medicine to treat a variety of illnesses.¹⁹ A clinical study of a cosmetic formula containing 2% *Orthosiphon stamineus* leaf extract was conducted in France and Thailand. The cosmetic formula was applied twice daily for 28 days. In the Caucasian group, there was a significant reduction in shiny appearance (17.5%) and pore size (30%) ($p < 0.1$, $p < 0.001$). There was a 28% and 35% improvement in skin complexion evenness and radiance ($p < 0.001$). In the Asian group, there was a 25% significant reduction in shiny appearance and 20% reduction in pore size ($p < 0.001$). This cosmetic formula containing 2% *Orthosiphon stamineus* leaf extract appears to reduce oily skin and restore the imperfections from the overproduction of sebum.¹⁹

TABLE 28.1

Agents Studied for Modulation of Sebum Production

Study Agent	Study Type	Application Instructions	Outcome	Reference
<i>Melaleuca alternifolia</i> (tea tree oil)	<i>In vitro</i> study on the activity of <i>Malassezia furfur</i> strains, yeasts, and dermatophyte species	N/A	At higher concentrations of tea tree oil, antifungal effects seen for <i>Malassezia furfur</i> strains, yeasts, and dermatophytes	13
pH change, addition of NaCl, addition of cinnamic acid (& related compounds)	<i>In vitro</i> study to measure growth of <i>M. ovalis</i>	N/A	pH 4.5, pH 3.0: growth inhibition of 95% and 99.5% cinnamic acid inhibitory at 0.005 g/dL (50% reduction of mycotic growth ($p < 0.01$)* <i>o</i> -coumaric acid inhibitory at 0.5 g/dL (90% reduction of mycotic growth) ($p < 0.01$)*	15
<i>Monarda fistulosa</i> essential oil (MEO) and lavender essential oil (LEO)	<i>In vitro</i> (MEO & LEO) and animal study (MEO)	N/A	MEO more inhibitory to microorganism growth compared to LEO Mouse study: MEO has similar anti-inflammatory effects to hydrocortisone-vitamin B ₆ combination	18
<i>Ilex paraguariensis</i>	<i>In vitro</i> study evaluating growth of <i>M. furfur</i> with addition of aqueous extract of <i>Ilex paraguariensis</i>	N/A	<i>M. furfur</i> activity inhibited Similar to use of ketoconazole (2.7 µg/mL) Topical medication with <i>Ilex paraguariensis</i> for prevention and treatment of seborrheic dermatitis	16
<i>Cladia aggregate</i> (Swartz) Nyl.	<i>In vitro</i> study to evaluate antimicrobial properties	N/A	Anti- <i>Malassezia</i> properties Possible use for treatment of seborrheic dermatitis	14
Cream with 2% <i>Sesamum indicum</i> (sesame) seed extract, <i>Argania spinosa</i> kernel oil, and <i>Serenoa serrulata</i> (saw palmetto) fruit extract, 0.1% vitamin B ₆ , titanium dioxide	Clinical study in 20 subjects with oily skin	Applied twice daily for 4 weeks	33% reduction in mean score for severity of oily skin ($p < 0.001$)* 20% reduction in sebum level on forehead and cheeks ($p < 0.001$)* 42% reduction in sebum area and area covered by oily spots ($p < 0.001$)*	23
Cosmetic formula of 2% <i>Orthosiphon stamineus</i> leaf extract or placebo (1% zinc gluconate)	Clinical study in France (50 subjects) and Thailand (40 subjects) with oily skin	Applied twice daily for 4 weeks	<i>Caucasian group in France:</i> 17.5% reduction in shiny appearance ($p < 0.01$)* 30% reduction in pore size ($p < 0.001$)* 28% and 35% improvement in evenness of skin complexion and radiance in treatment group, respectively ($p < 0.001$)* Self-evaluation: More even complexion (80%), radiant skin (100%), and improved skin texture (92%); ($p < 0.05$)*	19

(Continued)

TABLE 28.1 (Continued)

Agents Studied for Modulation of Sebum Production

Study Agent	Study Type	Application Instructions	Outcome	Reference
Glycerol alkyl-ether based cream	Split-face clinical study in 20 males with seborrheic dermatitis	Cream applied twice daily for 12 weeks	<p><i>Asian group in Thailand:</i> 25% reduction in shiny appearance ($p < 0.001$)* 20% reduction in pore size ($p < 0.001$)* Self-evaluation: Skin less oily (81%), improved texture (71%), imperfections less visible (76%) after treatment period</p> <p><i>Week 12:</i> Significant decrease in sebum casual levels for treated area ($p < 0.01$)* Significant decrease in sebum excretion rate for treated area ($p < 0.01$)*</p>	26
5% tea tree oil shampoo	Randomized, single-blind clinical study in 126 subjects with mild to moderate dandruff	Applied daily for 4 weeks	<p>41.2% decrease in whole scalp lesion score for tea tree oil shampoo group vs. 11.2% in placebo group</p> <p>Overall improvement in total area of involvement score, severity score, itchiness, and scaliness in treatment group</p>	24
Shampoo containing 0.1% lipohydroxyacid (LHA) and 1.3% salicylic acid	Open study in 275 subjects (226 with seborrheic dermatitis, 49 with scalp psoriasis)	Applied on alternate days	<p>Seborrheic dermatitis subjects: 91% experienced improvement in clinical scalp conditions (composite lesional score) ($p < 0.00001$)*</p> <p>Quality of life scores improved after treatment ($p < 0.00001$)*</p>	28
Treatment with LHA (0.1% lipohydroxy acid and 1.3% salicylic acid) shampoo or CPO (1.5% ciclopiroxolamine, 3% salicylic acid, and 0.5% menthol)	Randomized, double-blind clinical study in 100 subjects with scalp seborrheic dermatitis	Shampoo every 2 days for 4 weeks in subjects with scalp seborrheic dermatitis	<p>Decrease in symptoms in all subjects ($p \leq 0.05$)*</p> <p>LHA group had greater instance of improvement</p> <p>Global efficacy and tolerance of LHA shampoo group better than CPO shampoo group (<i>efficacy</i>: 100% vs. 88%, $p = 0.03$)* (<i>tolerance</i>: 70% vs. 53%, $p = 0.01$)*</p>	29

(Continued)

TABLE 28.1 (Continued)

Agents Studied for Modulation of Sebum Production

Study Agent	Study Type	Application Instructions	Outcome	Reference
Topical modulator of toll-like receptor 2 (TLR2)	Double blind comparative clinical trial in 115 subjects with seborrheic dermatitis	Twice daily application of topical agent for 8 weeks	<p><i>Week 4:</i> Relapse seen in 9% of cases in TLR2 modulator group and 21% of cases in placebo group <i>Relapse rate:</i> 26% in TLR2 modulator group and 43% in placebo group <i>Week 8:</i> Relapse seen in 5% of cases in TLR2 group and 10% of cases in placebo group <i>Relapse rate:</i> 21% in TLR2 group and 40% in placebo group ($p = 0.0309$)* <i>Global efficacy:</i> Week 4: good efficacy on relapse prevention in 98% of patients in TLR2 group vs. 84% in placebo group ($p = 0.0003$)* Week 8: good efficacy on relapse prevention in 95% of patients in TLR2 group vs. 81% in placebo group ($p = 0.0012$)* <i>Skin tolerance:</i> 98% (TLR2 group) <i>Self-assessment:</i> 89% of patients in TLR2 group at W4 believed there was a delay in SD outbreak vs. 72% of those in placebo ($p = 0.0155$)*, 93% in TLR2 group believed the same at W8 vs. 69% from placebo group ($p = 0.0014$)* Did not use antifungal or steroid</p>	27
Test shampoo with piroctone olamine and climbazole or comparative shampoo	Randomized, double-blind, controlled clinical study in 34 subjects with dandruff and/or seborrheic dermatitis	Shampoo twice weekly for 4 weeks	<p>52% and 66% reduction in skin scalp desquamation in test shampoo (week 2 and 4) ($p < 0.05$)* Reduction in number of scales seen in subjects from test shampoo (week 2) ($p < 0.05$)* 50% of test group subjects saw an improvement compared to 29% of comparative group subjects (week 4)</p>	30

Botanical compounds such as saw palmetto extract, phytosterols, and essential fatty acids are considered to inhibit 5 α -reductase.^{20–22} An *in vitro* study with a topical containing saw palmetto, sesame seeds, and argan tree oil suggested an inhibitory effect on skin 5 α -reductase, and therefore a possible treatment for oily skin.²³ A clinical study evaluated the effectiveness of a novel cream composed of polyphenol-rich extract from *Sesamum indicum* seed extract, *Argania spinosa* kernel oil, and *Serenoa serrulata* fruit extract in patients with oily skin. Patients applied the cream twice daily for four weeks. There was a significant reduction in the severity of oily skin after the treatment period. Specifically, a 20% reduction in sebum level on the forehead and cheeks was reported ($p < 0.001$). A 42% decrease in the sebum area and the area covered by oily spots was seen in patients ($p < 0.001$). Ninety-five percent of patients reported that the cosmetic cream was tolerable, with no reports of adverse events during the study. Study outcomes suggest the use of this specific cream for patients with oily facial skin.²³

Agents Studied for Seborrheic Dermatitis

One clinical study evaluated the effectiveness and tolerability of 5% tea tree oil shampoo in subjects with mild to moderate dandruff.²⁴ Tea tree oil has antimicrobial properties against *P. ovale*, and as a result may treat dandruff.²⁵ Following the daily, four week treatment period, there was a 41.2% decrease in the whole scalp lesion score for patients who used the 5% tea tree oil shampoo compared to an 11.2% reduction in patients who used the placebo shampoo. Among patients who used the 5% tea tree oil shampoo, there was an improvement in the total area of involvement score, severity score, itchiness, and scaldiness. Ongoing treatment with 5% tea tree oil shampoo may be required to control dandruff. Significant adverse effects were not reported.²⁴

The anti-seborrheic activity of a glycerol alkyl-ether based cream was evaluated in a split-face clinical study.²⁶ After 12 weeks of treatment, there was a significant reduction in sebum casual levels on the treated skin area vs. control ($p < 0.01$). There was a significant reduction in the sebum excretion rate in the treated skin ($p < 0.01$).

A comparative clinical trial evaluated the effect of a topical modulator of toll like receptor 2 (TLR2), TLR2-Regul™ for the prevention of seborrheic dermatitis.²⁷ Midway through the treatment period, 9% of patients in the treatment group had a relapse compared to 21% of those in the placebo group. The relapse rate was 26% in the treatment group and 43% in the placebo group. At the end of the treatment period, relapse was experienced in 5% of patients receiving treatment vs. 10% in the placebo group. The relapse rate was 21% and 40% in the treatment and placebo group, respectively ($p = 0.0309$). Ninety eight percent of patients in the treatment group reported an excellent tolerance with the topical product. Overall, the group given the topical TLR2-Regul™ experienced a significantly less relapse rate when compared to the placebo group.²⁷

Shampoo

A shampoo containing 0.1% lipohydroxyacid (LHA) and 1.3% salicylic acid was evaluated on patients with seborrheic dermatitis or scalp psoriasis.²⁸ In 91% of patients with seborrheic dermatitis, there was a significant improvement in clinical scalp conditions ($p < 0.00001$). Furthermore, a significant improvement in the quality of life scores was seen after treatment with the LHA shampoo. This specific formulation was safe, effective, and well tolerated.²⁸

A comparison study of treatment with LHA shampoo vs. ciclopiroxolamine (CPO) was conducted in patients with scalp seborrheic dermatitis.²⁹ CPO is one shampoo used for the treatment of scalp seborrheic dermatitis, with ketoconazole being more common. The LHA and CPO shampoo both resulted in a significant decrease in symptoms (scale, itching, and erythema) ($p \leq 0.05$). Patients that used the LHA shampoo experienced a greater instance of improvement compared to those in the CPO group. The global efficacy and tolerance of LHA shampoo was significantly better than the CPO shampoo ($p = 0.03$, $p = 0.01$, respectively). For the LHA shampoo, cosmetic acceptability for both cleaning and lathering was significantly better when compared to the CPO shampoo ($p = 0.02$, $p = 0.04$).²⁹

A randomized controlled study evaluated the antidandruff activity of a test shampoo.³⁰ The test shampoo contained piroctone olamine and climbazole. Piroctone olamine is a common replacement for zinc pyrithione. There was a significant reduction in skin scalp desquamation and in the number of scales in the test shampoo group ($p < 0.05$). Furthermore, 50% of patients from the test group experienced an improvement in conditions compared to 29% in the comparative group. No adverse events were reported during the study.³⁰

Conclusion

There are several cosmeceutical options for the improvement of oily skin and seborrheic dermatitis. Many of the studies are *in vitro*, and only a few clinical studies are available. As the field of cosmeceuticals continues to grow, so will the treatment options for management of oily skin and seborrheic dermatitis.

REFERENCES

1. Gupta AK, Bluhm R. Seborrheic dermatitis. *J Eur Acad Dermatol Venereol* 2004;18(1):13–26; quiz 19–20.
2. Sampaio AL. et al. Seborrheic dermatitis. *An Bras Dermatol* 2011;86(6):1061–71; quiz 1072–4.
3. Wu Y et al. A preliminary investigation of the impact of oily skin on quality of life and concordance of self-perceived skin oiliness and skin surface lipids (sebum). *Int J Cosmet Sci* 2013;35(5):442–7.
4. Dawson TL. Jr. *Malassezia globosa* and *restricta*: Breakthrough understanding of the etiology and treatment of dandruff and seborrheic dermatitis through whole-genome analysis. *J Investig Dermatol Symp Proc* 2007;12(2):15–9.
5. DeAngelis YM et al. Three etiologic facets of dandruff and seborrheic dermatitis: *Malassezia* fungi, sebaceous lipids, and individual sensitivity. *J Investig Dermatol Symp Proc* 2005;10(3):295–7.
6. Selden ST. Immune response to *Pityrosporum orbiculare* and seborrheic dermatitis. *Am Fam Physician* 1996;53(7):2278, 2282.
7. Lian CH et al. Identification of *Malassezia* species in the facial lesions of Chinese seborrheic dermatitis patients based on DNA sequencing. *Mycoses* 2014;57:759–64.
8. Mathes BM, Douglass MC. Seborrheic dermatitis in patients with acquired immunodeficiency syndrome. *J Am Acad Dermatol* 1985;13(6):947–51.
9. Soeprono FF et al. Seborrheic-like dermatitis of acquired immunodeficiency syndrome. A clinicopathologic study. *J Am Acad Dermatol* 1986;14(2 Pt 1):242–8.
10. Burton JL, Cartlidge M, Shuster S. Effect of L-dopa on the seborrhea of Parkinsonism. *Br J Dermatol* 1973;88(5):475–9.
11. Binder RL, Jonelis FJ. Seborrheic dermatitis in neuroleptic-induced parkinsonism. *Arch Dermatol* 1983;119(6):473–5.
12. Penfold AR, Grant R. The germicidal values of some Australian essential oils and their pure constituents: Together with those for some essential oil isolates, and synthetics. Part III. *J Proc Roy Soc NSW* 1925;59:346–50.
13. Nenoff P, Haustein UF, Brandt W. Antifungal activity of the essential oil of *Melaleuca alternifolia* (tea tree oil) against pathogenic fungi *in vitro*. *Skin Pharmacol* 1996;9(6):388–94.
14. Pandey A et al. Management of cosmetic embarrassment caused by *Malassezia* spp. with fruticose lichen *Cladia* using phylogenetic approach. *Biomed Res Int* 2013;2013:169794.
15. Baroni A et al. New strategies in dandruff treatment: Growth control of *Malassezia ovalis*. *Dermatology* 2000;201(4):332–6.
16. Filip R, Davicino R, Anesini C. Antifungal activity of the aqueous extract of *Ilex paraguariensis* against *Malassezia furfur*. *Phytother Res* 2010;24(5):715–9.
17. Gonzalez A et al. Biological screening of Uruguayan medicinal plants. *J Ethnopharmacol* 1993;39(3):217–20.
18. Zhilyakova ET et al. Study of *Monarda fistulosa* essential oil as a prospective antiseborrheic agent. *Bull Exp Biol Med* 2009;148(4):612–4.

19. Vogelgesang B et al. On the effects of a plant extract of *Orthosiphon stamineus* on sebum-related skin imperfections. *Int J Cosmet Sci* 2011;33(1):44–52.
20. Liang T, Liao S. Growth suppression of hamster flank organs by topical application of gamma-linolenic and other fatty acid inhibitors of 5alpha-reductase. *J Invest Dermatol* 1997;109(2):152–7.
21. Liang T, Liao S. Inhibition of steroid 5 alpha-reductase by specific aliphatic unsaturated fatty acids. *Biochem J* 1992;285(Pt 2):557–62.
22. Delos S et al. Testosterone metabolism in primary cultures of human prostate epithelial cells and fibroblasts. *J Steroid Biochem Mol Biol* 1995;55(3–4):375–83.
23. Dobrev H. Clinical and instrumental study of the efficacy of a new sebum control cream. *J Cosmet Dermatol* 2007;6(2):113–8.
24. Satchell AC et al. Treatment of dandruff with 5% tea tree oil shampoo. *J Am Acad Dermatol* 2002;47(6):852–5.
25. Hammer KA, Carson CF, Riley TV. *In vitro* susceptibility of *Malassezia furfur* to the essential oil of *Melaleuca alternifolia*. *J Med Vet Mycol* 1997;35(5):375–7.
26. Pierard-Franchimont C et al. Sebum rheology evaluated by two methods *in vivo*. Split-face study of the effect of a cosmetic formulation. *Eur J Dermatol* 1999;9(6):455–7.
27. Ionescu MA et al. Double blind clinical trial in a series of 115 patients with seborrheic dermatitis: Prevention of relapses using a topical modulator of Toll like receptor 2. *G Ital Dermatol Venereol* 2011;146(3):185–9.
28. Seite S et al. A lipohydroxyacid-containing shampoo improves scalp condition and quality of life in patients with seborrheic dermatitis and light-to-moderate scalp psoriasis. *J Cosmet Dermatol* 2009;8(2):108–13.
29. Seite S, Rougier A, Talarico S. Randomized study comparing the efficacy and tolerance of a lipohydroxy acid shampoo to a ciclopiroxolamine shampoo in the treatment of scalp seborrheic dermatitis. *J Cosmet Dermatol* 2009;8(4):249–53.
30. Sparavigna A et al. Assessment of the antidandruff activity of a new shampoo: A randomized, double-blind, controlled study by clinical and instrumental evaluations. *Skinmed* 2013;11(2):85–91.

Cosmeceutical Treatments for Purpura

Michael S. Leo and Raja K. Sivamani

Overview

Purpura is characterized by a nonblanching red or purple discoloration of the skin. It occurs when small blood vessels leak blood into the extravascular tissue. Purpura can develop due to many different causes that either cause damage and leakage of superficial blood vessels or due to conditions that may lead to prolonged clotting. Several examples, including the use of blood thinners, connective tissue diseases, severe infections, photoaging with decreased collagen, and injury can all result in purpura. Although some purpura can develop secondary to a systemic medical condition, most purpura are considered benign and secondary to photoaging, localized trauma, and the use of a blood thinner. Purpura can develop as a side effect of cosmetic and surgical procedures and become unsightly. This chapter focuses on the topical treatment of benign purpura that is not due to a systemic medical illness. Oral treatments are not discussed here.

Etiology of Benign Purpura

Solar and senile purpura is defined as the development of purpura due to breakage of superficial vessels in the dermis as a result of their fragility. Old age combined with sun exposure has been associated with the appearance of benign purpura.^{1,2} Purpura has also been associated with hyperglobulinemia³ as well as hypercoagulable states⁴ that increase the likelihood of venous or arterial thrombosis. Treatment with blood thinners such as warfarin, acenocoumarol, coumadin, or phenprocoumon can also increase the risks for hemorrhage and thereby lead to purpura.⁵

Clinical Studies (Table 29.1)

Topical Vitamin K

A patient study involving the topical application of vitamin K before and after pulsed laser treatment on one side of the face for two weeks revealed that application of vitamin K before treatment did not reduce bruising compared to the vehicle control.⁶ However, application of vitamin K after laser treatment significantly reduced bruising as measured through a visual analog scale (VAS), with the vitamin K group having a mean VAS of 3.858 compared to the placebo's mean of 4.364.⁶ These results are reinforced by a similar study demonstrating that topical vitamin K with retinol significantly reduced traumatic purpura when applied after laser treatment.⁷ A significant decrease in discoloration was evident by three days of topical treatment.⁷ In another study, purpura was induced with injections of autologous blood and then treated with topical vitamin K. Resolution of purpura in the topical vitamin K treatment group occurred in 5–8 days compared to the 11–13 days for the non-treated group.⁸ However, a separate study that used suction cups to induce bruising applied showed no reduction in purpura after one week of topical application of 0.5% vitamin K for one week.⁹ These differences in results are likely due to the fact that Kovacs et al. used a 0.5% vitamin K ointment compared to the 5% vitamin K ointment that Shah et al.

TABLE 29.1

Effect of Topical Agents on Purpura

Topical Agent	Outcome	Reference
0.5% vitamin K	No effect	4
1% vitamin K	Improved purpura	3
1% vitamin K + 0.3% retinol	Improved purpura	2
5% vitamin K	Improved purpura	1
10% arnica	No effect	5
20% arnica	Improved purpura	6

used. Prophylactic use of topical vitamin K does not appear to prevent the development of purpura, but may help speed up its resolution when used on existing purpura.

Topical *Arnica Montana*

Arnica montana plant extract was prepared into a 10% topical gel and applied for two weeks pre- and post-laser treatments for facial telangiectases. Results revealed that topical *Arnica* treatment did not significantly decrease purpura lesions as compared to the vehicle control in both pre- and post-laser treatment groups.¹⁰ However, another study compared topical white petroleum, 1% vitamin K and .3% retinol, 5% vitamin K, and 20% arnica treatment for two weeks after laser-induced purpura. All treatment options performed better than the petroleum control. Furthermore, topical 20% arnica was shown to significantly improve the appearance of purpura after two weeks, more than every other treatment option except for the 5% vitamin K gel.¹¹ These results suggest that 10% arnica is not a sufficient concentration, whereas 20% arnica is adequate for the treatment of laser-induced purpura.

Side Effects

No side effects were reported for treatment with either arnica or topical 5% vitamin K ointments.^{6,8,10,11} However, one patient from the 1% vitamin K and 0.3% retinol treatment group reported a mild irritant dermatitis and was excluded from the study after stopping treatment.⁷

Conclusion

The topical treatment of purpura should begin with ruling out any systemic causes or associations that may require medical therapy. No topical cosmeceutical agents appear to be effective as prophylactic and preventative agents against benign purpura. Although there has yet to be extensive research on the various cosmeceutical treatments for benign purpura, topical vitamin K and topical *Arnica montana* may be useful in hastening its resolution.

REFERENCES

1. Waters AJ, Sandhu DR, Green CM et al. Solar capillaritis as a cause of solar purpura. *Clin Exp Dermatol* 2009;34(8):e821–4.
2. Rubegni P, Feci L, Pellegrino M et al. Photolocalized purpura during levofloxacin therapy. *Photodermatol Photoimmunol Photomed* 2012;28(2):105–7.
3. Waldenstrom J. Three new cases of purpura hyperglobulinemica. A study in long-lasting benign increase in serum globulin. *Acta Med Scand Suppl* 1952;266:931–46.
4. Thornsberry LA, LoSicco KI, English JC, 3rd. The skin and hypercoagulable states. *J Am Acad Dermatol* 2013;69(3):450–62.

5. Levi M, Eerenberg E, Kamphuisen PW. Bleeding risk and reversal strategies for old and new anticoagulants and antiplatelet agents. *J Thromb Haemost* 2011;9(9):1705–12.
6. Shah NS, Lazarus MC, Bugdodel R et al. The effects of topical vitamin K on bruising after laser treatment. *J Am Acad Dermatol* 2002;47(2):241–4.
7. Lou WW, Quintana AT, Geronemus RG et al. Effects of topical vitamin K and retinol on laser-induced purpura on nonlesional skin. *Dermatol Surg* 1999;25(12):942–4.
8. Elson M. Topical phytonadione (vitamin K1) in the treatment of actinic and traumatic purpura. *Cosmetic Dermatol* 1995;8:25–7.
9. Kovacs RK, Bodai L, Dobozy A et al. Lack of the effect of topical vitamin K on bruising after mechanical injury. *J Am Acad Dermatol* 2004;50(6):982–3.
10. Alonso D, Lazarus MC, Baumann L. Effects of topical arnica gel on post-laser treatment bruises. *Dermatol Surg* 2002;28(8):686–8.
11. Leu S, Havey J, White LE et al. Accelerated resolution of laser-induced bruising with topical 20% arnica: A rater-blinded randomized controlled trial. *Br J Dermatol* 2010;163(3):557–63.

Vitiligo (Repigmentation Agents)

Amir Al-Dabagh, Andrea M. Hui, and Bishr Al Dabagh

Introduction

Vitiligo is an acquired pigmentation disorder characterized by loss of pigment of the skin, mucosa, or hair due to destruction of melanocytes. The goals of vitiligo treatment are repigmentation and cessation of depigmentation. A combination of treatments is often utilized to provide as much repigmentation as possible. Studies have shown that 70%–80% of patients will regain partial repigmentation with treatment, but only 20% will regain full pigmentation.¹ Repigmentation occurs in a perifollicular pattern, usually from the edges of the lesions. Although there is no one optimal treatment for vitiligo, a combination of first- and second-line topical and oral treatments provides many patients with adequate repigmentation. There are continually new treatments being developed which may further improve repigmentation in combination with traditional medical therapy. This chapter reviews a wide range of available therapies and outlooks for the future in the treatment of vitiligo.

Background

Vitiligo affects 0.5%–1% of the world's population and can be psychosocially devastating for many.² It affects men and women of all races equally and can occur at any age, although half of cases present before the age of 20.³ The causes of vitiligo are multifaceted and include autoimmunity and oxidative stress, among others.

Types of Vitiligo

Clinical Features

The lesions of vitiligo are completely depigmented (white) macules or patches surrounded by normally pigmented skin. Lesions tend to occur unpredictably and insidiously. The white patches of vitiligo are more clinically apparent on darker skin. In light-skinned individuals, lesions can be better visualized with a Wood's lamp. The lesions are well demarcated and can present in any variety of shapes with characteristically convex borders. The lesions may be of any size, from a few millimeters to encompassing entire anatomic areas of the body.

Lesions may appear anywhere on the body but tends to prefer areas that are normally hyperpigmented such as the face, dorsal hands, nipples, and genitals. Lesions may also commonly appear on areas of repeated friction such as elbows, knees, fingers, wrists, and ankles. Facial vitiligo tends to occur around the eyes and mouth. Vitiligo lesions are generally asymptomatic but can sometimes itch.

The course of vitiligo is unpredictable. In some, the course may be slowly progressive over long periods of time and can stabilize or, rarely, resolve. In others, total-body depigmentation can occur within weeks. Currently, there is no valid scoring system to assess vitiligo severity, or even to define active versus stable vitiligo.⁴ Lesions of vitiligo tend to spread centrifugally. There are no preceding signs of vitiligo development, though clinical erythema may be noted.

Classification of Vitiligo

Vitiligo may be classified into three categories: (1) localized; (2) generalized; and (3) universal. Over 90% of vitiligo patients present with the generalized type.⁴

Localized vitiligo does not cross the midline of the body. It may present as one or more macules in a single area but not segmentally distributed (focal), involving a unilateral segment (segmental), or involving only the mucous membranes (mucosal). Segmental vitiligo presents more commonly in children, accounting for 15%–30% of cases in the pediatric population.⁴

Generalized vitiligo crosses the midline. It may present with widely distributed scattered patches (vulgaris), occur on the distal extremities and face (acrofacial), and can be a combination of segmental and generalized vitiligo (mixed).

Universal vitiligo is the most severe presentation of vitiligo. It presents as total or near-total depigmentation of the entire body.

Pathophysiology of Vitiligo

Autoimmunity, resulting in the destruction of melanocytes, is a widely accepted theory in the pathogenesis of vitiligo. Antibodies against melanocyte proteins such as tyrosinase, TRP-2, and SOX10 can be found in the serum of patients with vitiligo⁵; furthermore, levels of these autoantibodies correlate with the extent of disease activity.⁶ There is also a significant association between vitiligo and other autoimmune diseases, such as alopecia areata, Addison's disease, systemic lupus erythematosus, thyroid diseases (Graves' disease, Hashimoto thyroiditis), rheumatoid arthritis, pernicious anemia, among others.^{7,8} Additionally, cell-mediated immunity also plays a role in vitiligo pathogenesis; high levels of melanocyte-reactive cytotoxic T cells can be demonstrated in the peripheral blood of patients with vitiligo, as well as perilesional infiltration of T-cells and associated melanocyte loss.^{9–12} Repigmentation is often restored when patients are treated with immunosuppressive agents such as corticosteroids, ultraviolet (UV) radiation with psoralens (PUVA), and immunomodulating agents such as calcineurin inhibitors. This further supports the theory that autoimmunity is involved in the pathogenesis of vitiligo.

The oxidative stress theory postulates that a defective defense mechanism against toxic free radicals can lead to destruction of melanocytes. Reactive oxygen species (ROS), including hydrogen peroxide (H₂O₂), are normally produced by melanocytes during melanogenesis and are removed by a healthy antioxidant enzyme system including catalase.¹³ In vitiligo, defects in this antioxidant system can cause a build-up of ROS, which are directly toxic to melanocytes and can inhibit tyrosinase.¹⁴ Additionally, ROS build-up can create an inflammatory environment in which autoimmunity can be induced. ROS has been demonstrated in the activation of cytotoxic T-cells and the inflammatory cytokine pathway.¹⁵ Accumulated oxidative stress causes DNA damage, lipid, and protein peroxidation.^{16,17} Based upon the involvement of ROS in the pathophysiology of vitiligo, we expect the investigation of antioxidants for the treatment of vitiligo to be of great interest in the future.

First-Line Treatments

Topical Therapies

Topical corticosteroids are the most widely used first line treatment and are considered to be the most effective monotherapy. Given their widespread availability, relative affordability, ease of application, and high monotherapy success rates, they are usually the primary treatment modality. Repigmentation is higher when topical corticosteroids are combined with UV light therapy or sun exposure.¹⁸ Children tend to have better responses than adults, and certain locations are more responsive (head and neck).¹⁹ Of course there are inherent risks with continued topical steroid use, including atrophy, striae formation, systemic absorption, glaucoma, cataracts, and tachyphylaxis. Depigmentation may recur after discontinuation of treatment. Topical steroids may also be combined with other topical medications to increase efficacy and decrease the rate of side effects.

Calcineurin Inhibitors

Generally, calcineurin inhibitors (CIs) are considered safer than topical corticosteroids and yet offer comparable efficacy due to immune modulation. Topical tacrolimus and pimecrolimus, similar to topical corticosteroids, are most efficacious when used on the head and neck. Occlusion provides better drug penetration on the extremities and increases responsiveness.²⁰ Childhood vitiligo may be successfully treated with CIs, avoiding the more deleterious side effects of topical steroids. Adjuvant treatment with the excimer laser (308 nm) has been shown to enhance efficacy of topical CIs, especially in treatment-resistant areas such as bony prominences.^{21–23}

Phototherapy: NBUVB and Photochemotherapy

Narrow-band UVB (NBUVB) is an effective treatment modality for vitiligo. It may be used in children, pregnant or lactating women, and in those with kidney or liver dysfunction.²⁴ It works via local immunosuppression to arrest melanocyte destruction and by inducing tyrosinase and the stem cells in the hair follicle and interfollicular epidermis to restore pigment.^{19,25} The excimer laser emits monochromatic light at 308 nm and is similar to NBUVB. It is fast, effective, and safe and may be used in concert with topical corticosteroids or CIs.²⁶ This laser treats localized vitiligo patches and thus decreases the side effects of traditional NBUVB used over large surface areas. Patients who have not responded to UVB treatment may respond to the excimer laser. It is particularly useful in those with Fitzpatrick skin types III–VI.²⁵

Second-Line Treatments

Vitamin D Analogs

Vitamin D is an essential hormone synthesized in the skin upon exposure to UVB through a photochemical reaction. Vitamin D regulates calcium and bone metabolism, affects cell proliferation and differentiation, and helps regulate immune cells. Vitamin D exerts immunomodulatory effects by inhibiting T-cell transition through the cell cycle, as well as the expression of genes encoding TNF- α and interferon-alpha (IFN- α).²⁷ The direct effects of vitamin D on melanocytes are not fully understood, but may occur through upregulation of melanogenic cytokines, inhibition of melanocytic apoptosis, and protection against the excess ROS produced in vitiliginous skin.^{27,28} Compared with topical corticosteroids, vitamin D analogs have lower response rates. However, when used as adjuvant therapy, repigmentation is more pronounced and is faster than if either agent is used as monotherapy.¹⁹ The impact of vitamin D analogs on phototherapy is still a matter of debate.¹⁹

Other Treatments

Afamelanotide

Afamelanotide is a potent, linear synthetic analog of the naturally occurring peptide hormone α -melanocyte-stimulating hormone (α -MSH).²⁹ Modified to have a stronger binding affinity to melanocortin-1 receptor (MC1R) and a smaller disassociation constant, afamelanotide has a longer half-life and subsequently exerts longer pharmacologic activity than its parent hormone.^{29,30} Like α -MSH, this analog induces eumelanin synthesis, proliferation, and transport within the melanosome. In addition to acting on melanocytes and keratinocytes present in the epidermis and hair follicles, afamelanotide may also affect inflammatory cells, neutrophils, and lymphocytes, expressing MC1R, and restore balance to immunologic abnormalities involved in the pathogenesis of vitiligo. Thus, afamelanotide restores the physiologic effects of α -MSH and counters the defects occurring in the melanocortin system of vitiligo patients.³¹

On a systemic scale, lower plasma levels of α -MSH are associated with vitiligo. Vitiligo patients have approximately half the median level of α -MSH as their control counterparts.⁹ This observation is

independent of disease activity or any association with other autoimmune diseases, representing a possible immune-endocrine disposition for the occurrence of autoimmune depigmentation.

Pseudocatalase

While vitiligo clearly alters melanocyte function and number, the effects of this disease encompass the entire epidermis and extend to keratinocytes, Langerhans cells, and Merkel cells.^{10,32–34} Due to lipid peroxidation induced by H₂O₂, epidermal cells express varying degrees of cellular vacuolation and debris.^{34–39}

Several factors aggravate the cellular damage induced by H₂O₂. Although catalase mRNA expression remains unchanged, vitiligo patients have lower levels of catalase in their epidermis to counter high levels of H₂O₂.^{40–42} There are many cutaneous sources of intrinsic H₂O₂ production, including epidermal monoamine oxidase A activity, increased NADPH-oxidase activity from inflammatory cells (macrophages and neutrophils), increased epidermal tumor necrosis factor production, photo-oxidation of epidermal pterins (whose levels are high in acute vitiligo), inducible nitric oxide synthase, epidermal xanthine oxidase activity, and estrogen and progesterone-induced generation.^{43–48} Increasing levels of H₂O₂ directly damage melanocytic mitochondria and epidermal proopiomelanocortin (POMC)-derived neuropeptides, including α -MSH and B-endorphin, resulting in altered viability and/or functionality of melanocytes and keratinocytes.⁴⁹

Activated by NBUVB, pseudocatalase is a synthetic topical catalyst that has the ability to counter these effects by replenishing low catalase levels and reducing the concentration of H₂O₂.^{34,50} Pseudocatalase also corrects aberrations in the calcium homeostasis of vitiligo patients.⁵¹ Lesions are repigmented as homeostasis is achieved and epidermal cells recover from the oxidative stress, no longer exhibiting vacuolation.^{40,52,53} In a nonrandomized study of 33 patients, a combination therapy of pseudocatalase, calcium, and NBUVB arrested disease progression in 95% of adult patients, while initiating repigmentation in 60%.^{51,54}

A similar study was conducted on a pediatric population suffering from generalized ($n = 61$) or segmental vitiligo ($n = 10$).⁵⁵ Pseudocatalase was applied to the entire body surface before patients were irradiated with 0.15 mJ/cm² of NBUVB (equivalent to 5.6 hours of sunlight exposure per year). The protocol was performed daily for the first two weeks, twice daily for another four weeks, and then continued daily thereafter. Patients were evaluated after 8–12 months, and repigmentation was observed in all children receiving combination therapy. The best response was seen in the face/neck areas (93% showed >75% repigmentation), with impressive responses on the trunk (78%) and extremities (73%). The children's hands and feet responded disappointingly to treatment (9%), possibly due to the reduced numbers of follicle-originating melanocytes in these regions.⁵⁰ In comparison, ten children with vitiligo were treated with low-dose NBUVB monotherapy, and of these, seven children showed progression of their disease after six months.⁵⁵ Of note, repigmentation in the treatment arm was independent of age, skin color, gender, other demographic features, duration of disease, and previous treatments. Thus, it is not mandatory to treat children at a younger age to obtain a better general outcome. Treatment should be stopped once 100% pigmentation is achieved. Maintenance low-dose therapy should otherwise continue, with the option of re-initiating treatment with relapse.

The data provides encouraging results for the treatment of childhood vitiligo vulgaris, in contradiction to earlier studies using pseudocatalase far below its therapeutic level or original formulations of pseudocatalase inactivated by the addition of the preservative bronopol.⁵⁶ The same conclusion cannot be made for segmental vitiligo as the sample size was too small to deduce any treatment recommendations.

Topical Pseudocatalase Plus NBUVB

The first double-blinded, placebo-controlled, randomized trial conducted to evaluate the effects of pseudocatalase showed contradicting outcomes, however.⁵⁰ Vitiligo patients treated with pseudocatalase and NBUVB ($n = 14$) did not have significantly enhanced repigmentation in their face and hands compared with controls treated with NBUVB alone ($n = 18$). Within both the pseudocatalase and placebo arms, there was significant repigmentation from baseline, especially in facial lesions. These outcomes were

attributed to the NBUVB treatment both groups received and are consistent with earlier trials reporting the efficacy of NBUVB in repigmenting vitiligo lesions.^{57–59} Limitations of this trial were a small sample size and results restricted to the face and hands, with hands being particularly resistant to treatment as mentioned above. Taking into account the contradicting data, practitioners should consider pseudocatalase in more resistant cases of vitiligo. Further studies with larger sample sizes may be warranted to reconcile the opposing outcomes.

Combination Therapy with Dead Sea Climatotherapy

An alternative combined therapy of pseudocatalase cream and Dead Sea balneoclimatotherapy has been proposed, in light of the effectiveness of solar radiation and Dead Sea water bathing in the treatment of various cutaneous diseases, including vitiligo, psoriasis, and atopic dermatitis.^{60,61} The high salt concentration (346 g/L) enhances the efficacy of pseudocatalase treatment via several mechanisms: proinflammatory and chemotactic mediators are released, high MgCl₂ levels significantly improve Langerhans cells' capacity to present antigen, and the water itself filters UV radiation to remove the shortest segments of UVB and generate a unique, solar, narrow-band UV spectrum that increases the photosensitivity of patients following sea salt bathing.^{60,62–66} Under these conditions, the activation of pseudocatalase is augmented.^{40,52} In a randomized, placebo-controlled study of 59 vitiligo patients, faster repigmentation was noted with the combined therapy of topical pseudocatalase, Dead Sea bathing, and solar phototherapy ($n = 39$) than climatotherapy ($n = 10$) or pseudocatalase monotherapy ($n = 10$). These outcomes were confirmed by comparison with earlier studies.^{40,45,52,53} Of note, a lower sun exposure was used in this protocol than recommended for conventional vitiligo treatments at the Dead Sea (2 hours versus 7–8 hours per day). The faster onset of repigmentation seen with this new therapy holds promise for the future management of vitiligo patients, as outcomes lasted for at least three months.⁴⁵

Polypodium Leucotomos (Heliocare)

Plant extracts, administered topically or systemically, have shown promise in the treatment and management of various cutaneous diseases.⁶⁷ *Polypodium leucotomos* (PL), also known as the golden serpent fern of the natural order polypodiaceae, has strong anti-inflammatory properties and contains a rich concentration of antioxidant polyphenolic compounds that may protect against photodamage.^{67–74} In a small pilot study, both topically ($n = 5$) and systemically ($n = 8$) administered PL extract decreased PUVA erythema and psoralens-triggered phototoxic skin reactions.⁷² This photo-protective characteristic was confirmed by another study showing both clinical and histological reductions in UV-induced erythema.^{75,76}

UV-irradiated skin develops a higher incidence of cancer through several mechanisms.⁷⁷ Whereas immunosuppression allows cancerous cells to escape cell death and apoptosis, inflammation, upregulation of COX-2, and erythema create a malignant milieu by promoting tumor growth and ROS production.^{75,78,79} Of note, COX-2 is actively involved in cell differentiation and apoptosis, and its suppression precedes that of epidermal cell growth.⁸⁰ COX-2 inhibitors, including celecoxib and other nonsteroidal anti-inflammatory drugs (NSAIDs), prevent and reduce the *in vivo* growth rate of UV-induced skin cancers and also decrease the incidence of UV-generated skin cancers in mice by 55%–90%.^{81–84} However, NSAIDs have a number of well documented, and at times life-threatening, adverse effects that are not associated with PL.^{85–87}

As demonstrated in murine models, PL extract affords a safer alternative through a number of mechanisms: increasing active p53 expression, inhibiting inflammation and COX-2 enzyme levels following UV exposure, accelerating the removal of UV-generated photoproducts (i.e., cyclobutane pyrimidine dimers), and decreasing DNA mutations produced by oxidative UV damage.^{88–94} PL reduces the formation of ROS and free radicals and consequently prevents UV-induced inflammation, phototoxicity, and photodamage.^{75,76,95–97}

The normal response of human skin to UV radiation (290–400 nm) is recognized as a type of inflammation mediated by humoral and cellular reactions.⁷² Unattended, chronic UV exposure causes wrinkles,

diminished collagen and structural integrity, induction of matrix metalloproteinases (MMPs), accumulation of elastin and fibrillin, and impaired wound healing.^{98,99} PL prevents acute sunburn, upregulation of TNF- α , and the depletion of Langerhans cells. These preventative measures decrease inflammation, and may also play a role in PL's capability to prevent and treat pathogenic processes associated with photoaging.^{72,100,101}

Antioxidant and Immunomodulating Properties

Rich with antioxidant polyphenols, PL inhibits ROS that are important in the pathology of many human diseases, including autoimmune disorders.^{102,103} These ROS include superoxide anion, H₂O₂, singlet oxygen, and hydroxyl radicals, with the latter considered particularly damaging due to their strong activity.¹⁰⁴ Superoxide and H₂O₂ are primarily generated by phagocytes, and these two may react together in inflammatory processes to generate hydroxyl radicals, the most harmful ROS to tissues. ROS including singlet oxygen, superoxide, and hydroxyl radicals are commonly generated in organisms during photosensitized oxidation reactions.^{105–108} All ROS induce DNA damage by forming pyrimidine dimers, DNA protein crosslinks, DNA strand breaks, oxidation of thiols, and inactivation of SH-dependent enzymes.¹⁰⁹

In vitro, PL inhibited the hydroxyl radicals, the most deleterious ROS, at rates comparable to ascorbic acid and ethanol, both robust hydroxyl radical scavengers.¹⁰⁶ PL (1.0 mg/mL) also reduced the amount of detectable superoxide anion in buffer medium by 31% as compared to superoxide dismutase (99% inhibition). In the presence of riboflavin (RF), an endogenous chromophore, superoxide anions were generated by UV radiation in a dose-dependent manner. When added to this *in vitro* system, PL was able to quench 42%–55% of the superoxide anion produced.¹⁰⁴ PL also exhibited minimal inhibition (2.5%) of H₂O₂ versus catalase (99%). Although H₂O₂ is not exceptionally reactive with the majority of biologically significant molecules, it serves as an intracellular precursor of harmful hydroxyl radicals.¹⁰⁶ Nevertheless, this natural, nontoxic antioxidant was effective at scavenging the majority of ROS, including hydroxyl radicals, and may prevent H₂O₂ formation by inhibiting earlier steps of the ROS generation cycle. It was also efficacious in inhibiting superoxide anions and singlet oxygen, both of which are involved in the photosensitization process. *In vivo* studies on both guinea pig and human skin have confirmed these protective effects against UVB-induced erythema and PUVA-triggered phototoxic reactions.¹⁰⁴

In addition to scavenging ROS, PL improves membrane integrity, prevents lipid peroxidation, and also inhibits the expression of MMP-1 in fibroblasts and keratinocytes. These effects occur whether or not cells are exposed to UVA or UVB radiation.⁷⁴ The exception is that MMP-1 expression in fibroblasts is only inhibited with UV radiation, mainly UVB.

Lipid-laden cell membranes are remarkably vulnerable to attack by ROS, formed by univalent reduction of oxygen or by the transfer of UV energy to oxygen by photosensitizers.¹⁰⁴ The *in vitro* generation of lipid peroxides is dependent on the dose of UV exposure. PL exhibits a protective effect on both fibroblasts and keratinocytes by drastically inhibiting membrane damage and lipid peroxidation in both control and UV-irradiated cultures.⁷⁴ However, the doses of UVA and UVB utilized in this study are too low to cause direct membrane damage or lipid peroxidation in keratinocytes or fibroblasts. In another study, PL was able to decrease the concentration of superoxide anion, an important molecule in lipid peroxidation, by 50% following UVA radiation.¹⁰⁴

UV radiation also significantly induces MMP-1 expression in fibroblasts, via transcriptional mechanisms, whereas it mildly inhibits expression in keratinocytes.^{97,98,110–113} PL prevented MMP-1 expression in UV exposed fibroblasts. The same photoprotective effect is seen in keratinocytes, regardless of UV exposure.⁷⁴

Immunomodulatory Effects

PL acts as an immunosuppressive agent by modulating the Th1 response.¹¹⁴ The T1 response is characterized by the production of interleukin-2 (IL-2), interferon gamma (IFN- γ), and both TNF- α and β . The predominance of the Th1 pattern results in inflammatory and autoimmune diseases, such as vitiligo and psoriasis. This is in contrast to Th2, which is driven by interleukins 4, 5, 6, 10, and 13 and results in

allergy-associated diseases such as atopic dermatitis and asthma.^{115–118} The balance of Th1/Th2 can be modulated for the therapeutic management of these conditions.

PL inhibits the production of pro-inflammatory cytokines (TNF- α , IL-2, interferon-gamma, and IL-6) involved in the Th1 response,^{71,114,119} whereas it enhances IL-10 production. IL-10 is not only involved in the Th2 response, but it also indirectly prevents Th1 cytokine production via its inhibitory actions on macrophages. PL also alters the Th1/Th2 balance by mitigating delayed-type hypersensitivity reactions that are highly associated with the onset of Th1 responses.^{116,120,121} These effects have been confirmed *in vivo* using local lymph node assays and allogeneic skin rejection models.¹¹⁴

Oral P. Leucotomos in Combination with Narrow-Band UVB

Anecdotally, PL has been used as monotherapy for the treatment of vitiligo.¹²² In a placebo-controlled, double-blinded study, 50 vitiligo patients were randomized to receive 250 mg PL extract or placebo three times daily in combination with NBUVB (311 nm) twice weekly.¹²³ After 25–26 weeks, enhanced repigmentation was noted in the head and neck regions of the PL group (44% versus 27% of placebo, $P = 0.06$), and this outcome was statistically significant if patients attended more than 80% of their required NBUVB treatments (50% versus 19%, $P < 0.002$). The repigmentation was more clinically relevant in the PL group (72%) as compared to the placebo group (43%), though patients did not perceive a significant difference between the two treatments. No significant differences in repigmentation were noted in other body areas. Small increases in repigmentation were seen in the trunk (6%), hands and feet (5%), and extremities (4%). As confirmed by this study, hands and feet have the worst repigmentation rates with any treatment modality. Repigmentation may be more prominent in lighter Fitzpatrick skin types. Larger studies are warranted to confirm these results and assess its efficacy in darker skin, as the sample size for this subgroup was small ($n = 3$).¹²³

Combination Oral Antioxidants with NBUVB

As mentioned above, oxidative stress is involved in the pathogenesis of vitiligo.¹²⁴ Both the imbalance in the oxidative-reduction (redox) status and higher ROS production present in the epidermis are mirrored in peripheral blood mononuclear cells (PBMC), indicating vitiligo may be a systemic disease with confined clinical manifestations.¹²⁵ An antioxidant mixture (AM) containing alpha-lipoic acid, vitamin E and vitamin C has been used in combination with NBUVB to treat vitiligo. In both clinical trials and animal studies, alpha-lipoic acid restored the intracellular redox balance in various diseases, including diabetes, aging, and chemotherapy-induced oxidative stress.^{126–128}

Patients randomized to the treatment arm of a double-blind, placebo-controlled multicenter study were given two tablets daily for eight weeks before and during six months of biweekly NBUVB phototherapy.¹²⁵ The combined therapy prevented disease progression and increased the efficacy of NBUVB by restoring the intracellular redox status. The degree of repigmentation was enhanced, occurring more rapidly and at a lower cumulative NBUVB dose. After six months of phototherapy, 47% of patients treated with AM and NBUVB had >75% repigmentation versus only 18% in the placebo group ($P < 0.05$). The combination of AM plus NBUVB resulted in a larger number of patients experiencing increased catalase activity in PBMC (114% of baseline activity versus 91% for placebo, $P < 0.05$) and subsequently reduced H₂O₂. The reduced catalase activity seen in the placebo group was attributed to the oxidative stress induced by the NBUVB. The combination therapy also reduced both intracellular ROS generation (60% of basal production, $P < 0.02$) and membrane peroxidation in PMBC.

Topical Prostaglandin E

UV-induced turnover of membrane phospholipids generates prostaglandins and other byproducts that may provide activating cellular signals. Normal epidermal melanocytes swell and become more dendritic when cultured with prostaglandin E2 (PGE2), but not PGE1.¹²⁹ Applied topically, PGE2 induces an *in vivo* increase in the melanocyte density of mouse skin.¹³⁰ Histologic studies report PGE2 improves melanogenesis.¹³¹

Synthesized by keratinocytes, melanocytes, and Langerhans cells, PGE2 regulates melanocyte proliferation and has been observed under electron microscopy to stimulate melanocyte maturation, microfilaments orientation in dendritic processes, and melanosome complexing inside hair bulb melanocytes.¹³² Other mechanisms proposed for PG-induced hyperpigmentation include altered melanocyte responsiveness to neuronal stimuli and direct or second-messenger mediated stimulation of tyrosinase activity.¹³³

PGE2 also has immunosuppressive and immunostimulatory roles. It inhibits Langerhans cells from processing and presenting antigen in skin sensitized to dinitrofluorobenzene.¹³⁰ Like histamine, PGE2 has contradicting actions as it initially functions to trigger and augment the immune response but later limits, modulates, and contributes to the turning off of the same response.¹³⁴ Moreover, it modulates the suppression of monocyte major histocompatibility complex II (MHC-II) in biomaterial infection.¹³⁵

Twenty-four patients with limited vitiligo lesions were treated with topical PGE2 for six months.¹³¹ Significant to complete repigmentation was noted in 15 patients (63%), whereas another three had moderate repigmentation (13%). The remaining six showed little to no improvement. Many had perilesional hyperpigmentation, which disappeared with treatment discontinuation.

Alternative Therapies

Alternative and integrative treatments have been utilized for many centuries and continue to be a major part of healthcare today. There are many anecdotal reports and studies investigating the use of integrative medications for the treatment of vitiligo. It is important to realize that alternative therapies should not replace conventional treatment, but that it can enhance and broaden available options for this chronic disorder.

Ayurvedic Medicine

Ayurvedic medicine is a form of alternative medicine that originated in India over 3000 years ago. In India, the Ayurvedic system remains one of the traditional health care systems utilized to treat a variety of diseases. For a healthy body, one must achieve an equilibrium among the three energy components: *vayu* (wind), *pitta* (bile), and *kapha* (phlegm). Ayurvedic treatments are based on plants and herbal medications, with incorporation of exercise, yoga, and meditation. There are over 100 Ayurvedic treatment options to treat vitiligo.²⁶

Many oral Ayurvedic herbal treatments exist for vitiligo. Most are thought to work by stimulating melanogenesis. Some oral herbal treatments include: *Acacia catechu* bark liquid extract, *Psoralea corylifolia* leaves (containing psoralens), Usheer tea made from *Vetivexia zizanoidis*, and Brahmi tablets made from *Eclipta alba*. The side effect profiles for Ayurvedic herbal treatments have not been established, so caution must be taken when recommending these treatments. A majority of anecdotal reports include hepatotoxicity and contamination with heavy metals.^{136,137}

There are also several Ayurvedic topical herbal treatments for vitiligo. One topical preparation contains dried ginger, black pepper, pippali, and leadwort root, all fermented in cow's urine. Another combination contains *Psoralea corylifolia* in turmeric and mustard powder, basil leaves, and radish seeds with vinegar. These topical compounds are applied to the lesions with varying repigmentation results.²⁶

Other Ayurvedic treatments for vitiligo focus on relieving systemic symptoms, such as reduced digestion. Ayurveda panchakarma (detoxification) includes induced vomiting in order to remove toxins from the gastrointestinal tract, especially the liver and gall bladder. Other "body cleansing" vitiligo therapies include enemas, bloodletting, and drinking water kept in a copper vessel.¹³⁸

Herbal Remedies

A popular topical herbal treatment for vitiligo is available as anti-vitiligo oil originating from Pakistan. It contains several topical herbals with a variety of mechanisms of action to improve the lesions of vitiligo. *Psoralea corylifolia* is a naturally occurring psoralens, which sensitizes human skin to the tanning

effects of UV radiation. It is also a powerful antioxidant. Black cumin (seeds from *Nigella sativa*) works by mediating T cell- and natural killer cell-mediated immune responses. Barberry root (root of *Berberis vulgaris*) contains numerous antioxidant components, alkaloids, and cytoprotective properties.¹³⁹

Another topical herbal, piperine, is the major alkaloid of black pepper (*Piper nigrum*). It has been shown to stimulate melanocyte proliferation and dendrite formation *in vitro*. Piperine, when combined with UV radiation, has shown effectiveness in the treatment of vitiligo.¹⁴⁰

Other Treatments

Ginkgo biloba is one of the most popular alternative treatments for vitiligo. Ginkgo leaves contain anti-inflammatory and antioxidant polyphenols such as terpenoids (ginkgolides, bilobalides), flavonoids, and flavonoid extracts. It decreases oxidative stress in macrophages and endothelial cells by scavenging ROS. The biflavone component of ginkgo protects cells from UVB-induced cytotoxicity.¹³⁸ In a human study by Parsad et al., oral *G. biloba* 40 mg given three times daily resulted in significant repigmentation and halting of disease progression.¹³¹ In another study, *G. biloba* 60 mg given twice daily for 12 weeks halted disease completely and resulted in repigmentation in about 16% of subjects.

Metharmon-F (MF), a combination of sex steroids and thyroid hormone, has also been successful in treating vitiligo and fostering repigmentation.^{141,142} Five patients, unresponsive to oral corticosteroids and PUVA, were administered two MF tablets daily for 1–2 months. Each tablet contained pregnenolone (1.0 mg), androstendione (1.0 mg), estrone (5 ug), testosterone (0.1 mg), estrone (5 ug), and 7.5 mg of thyroid powder.¹⁴¹ Repigmentation was noted after treatment, and histologically, an increase in the number of melanocytes and melanin granules was observed. Immunoreactivity to α -MSH was stronger post-treatment in melanocytes, indicating that MF may stimulate melanocyte proliferation and melanin production through α -MSH.¹⁴¹

There has been some evidence that the amino acid L-phenylalanine, a precursor for melanin, could be a potential treatment for vitiligo. The combination of topical and oral L-phenylalanine and natural sunlight exposure has been shown to cause repigmentation in vitiligo lesions and is well tolerated.¹⁴³

Melagenina is a commercially available product developed in Cuba. It was originally extracted from human placental tissue; however, now animal placental tissues are used.^{20,33} Its active ingredient is a lipoprotein, and its mechanism of action is thought to be stimulation of melanoblast differentiation and melanocyte proliferation.¹⁴⁴ Topical application may be efficacious; one clinical study ($n = 20$) showed that 31% of patients showed repigmentation after applying it three times daily followed by 15 minutes of sun exposure.

Additionally, some vitamins may show anecdotal benefit in the treatment of vitiligo. Vitamin B12, vitamin C, and folic acid are thought to be effective due to their antioxidant properties.¹⁴⁵ Vitamin E reverses lipoperoxidation post-phototherapy whereas vitamin C acts as a reducing agent to inhibit damage caused by free oxygen radicals and slow oxidation.¹⁴⁶ Thus, these antioxidants act in different yet synergistic processes.^{147,148} Further studies need to be performed to determine mechanisms of action and efficacy of these alternative therapies for vitiligo. See [Table 30.1](#).

Conclusion

Vitiligo is a multifactorial pigmentation disorder characterized by the loss of skin pigment, which can be devastating for patients. There are many repigmentation agents available, and medical treatments such as topical corticosteroids and NBUVB provide excellent rates of repigmentation. New and alternative therapies for the treatment of vitiligo are continually being researched and developed. Based upon the involvement of ROS in vitiligo, we expect the investigation of antioxidants to be a high growth area in the future of vitiligo treatment. Excellent therapeutic outcomes can be achieved by a combination of first- and second-line treatments, and may be augmented by the addition of other treatments such as antioxidants and alternative therapies.

TABLE 30.1

Therapies for Vitiligo

Therapy	Mechanism of Action	Notes
First-Line Therapies		
Topical corticosteroids	Regulation of inflammation and immune response	The most effective monotherapy; repigmentation rate is higher when used in combination with other therapies
Topical calcineurin inhibitors (tacrolimus, pimecrolimus)	Immune modulation	Safer than topical corticosteroids, but with comparable efficacy
Phototherapy: NBUVB	Immunosuppression; induction of tyrosinase	May be used in children and pregnant or lactating women
Phototherapy: excimer laser	Similar to NBUVB	Ideal for localized vitiligo patches; use in patients who do not respond to NBUVB
Second-Line Therapies		
Topical vitamin D analogs	Regulation of cell proliferation and differentiation; immune modulation	Best used as adjuvant therapy, most commonly with topical corticosteroids
Other Treatments		
Systemic afamelanotide	Induces eumelanin synthesis, proliferation, and transport within the melanosome; immune modulation	Synthetic analog of α -MSH; lower α -MSH are associated with vitiligo (approximately half of normal)
Topical pseudocatalase	Reduces the concentration of H_2O_2 in epidermal cells, thus preventing cellular damage	Works best when used in combination with other therapies such as NBUVB
Dead Sea climatotherapy with pseudocatalase	Immune modulation via high salt and magnesium chloride concentration, and narrow-band UVB filtering	Faster repigmentation noted with this combination therapy versus monotherapy
Oral <i>Polypodium leucotomos</i>	Anti-inflammatory and antioxidant	Effective when combined with NBUVB
Topical prostaglandin E	Increase in melanocyte density and melanogenesis; immune modulation	May cause perilesional hyperpigmentation
Alternative Therapies		
Ayurvedic medicine	Stimulation of melanogenesis	Many oral Ayurvedic herbal treatments exist (see text)
Herbal remedies	Various; includes melanocyte stimulation, antioxidant properties, immune modulation	Several herbal treatments exist (see text)
Oral <i>Ginkgo biloba</i>	Anti-inflammatory and antioxidant	Appears effective in inducing repigmentation
Oral Metharmon-F	Analog or sex steroids and thyroid hormone	Effective for patients unresponsive to oral corticosteroids and PUVA
L-phenylalanine	Unknown	Combination oral and topical L-phenylalanine can induce repigmentation
Topical melaegenina	Extracted from placental tissues; stimulation of melanoblast differentiation and melanocyte proliferation	Efficacious as monotherapy and in combination with sun exposure
Vitamins	Antioxidant; unknown	Further studies needed

Note: NBUVB: narrow-band UVB; α -MSH: α -melanocyte-stimulating hormone; H_2O_2 : hydrogen peroxide.

REFERENCES

1. Wassef C, Lombardi A, Khokher S, Rao BK. Vitiligo surgical, laser, and alternative therapies: A review and case series. *J Drugs Dermatol* 2013;12(6):685–91.
2. Alikhan A, Felsten LM, Daly M, Petronic-Rosic V. Vitiligo: A comprehensive overview Part I. Introduction, epidemiology, quality of life, diagnosis, differential diagnosis, associations, histopathology, etiology, and work-up. *J Am Acad Dermatol* 2011;65(3):473–91.

3. Kyriakis KP, Palamaras I, Tsele E, Michailides C, Terzoudi S. Case detection rates of vitiligo by gender and age. *Int J Dermatol* 2009;48(3):328–9.
4. Bologna J, Jorizzo JL, Schaffer JV. *Dermatology*. 3rd edn. Philadelphia, PA: Elsevier Saunders; 2012.
5. Naughton GK, Eisinger M, Bystryn JC. Detection of antibodies to melanocytes in vitiligo by specific immunoprecipitation. *J Invest Dermatol* 1983;81(6):540–2.
6. Naughton GK, Reggiardo D, Bystryn JC. Correlation between vitiligo antibodies and extent of depigmentation in vitiligo. *J Am Acad Dermatol* 1986;15(5 Pt 1):978–81.
7. Alkhateeb A, Fain PR, Thody A, Bennett DC, Spritz RA. Epidemiology of vitiligo and associated autoimmune diseases in Caucasian probands and their families. *Pigment Cell Res* 2003;16(3):208–14.
8. Laberge G, Mailloux CM, Gowan K et al. Early disease onset and increased risk of other autoimmune diseases in familial generalized vitiligo. *Pigment Cell Res* 2005;18(4):300–5.
9. Pichler R, Sfetsos K, Badics B, Gutenbrunner S, Aubock J. Vitiligo patients present lower plasma levels of alpha-melanotropin immunoreactivities. *Neuropeptides* 2006;40(3):177–83.
10. van den Wijngaard R, Wankowicz-Kalinska A, Le Poole C, Tigges B, Westerhof W, Das P. Local immune response in skin of generalized vitiligo patients. Destruction of melanocytes is associated with the prominent presence of CLA+ T cells at the perilesional site. *Lab Invest* 2000;80(8):1299–309.
11. Mandelcorn-Monson RL, Shear NH, Yau E et al. Cytotoxic T lymphocyte reactivity to gp100, MelanA/MART-1, and tyrosinase, in HLA-A2-positive vitiligo patients. *J Invest Dermatol* 2003;121(3):550–6.
12. Lang KS, Caroli CC, Muhm A et al. HLA-A2 restricted, melanocyte-specific CD8(+) T lymphocytes detected in vitiligo patients are related to disease activity and are predominantly directed against MelanA/MART1. *J Invest Dermatol* 2001;116(6):891–7.
13. Casp CB, She JX, McCormack WT. Genetic association of the catalase gene (CAT) with vitiligo susceptibility. *Pigment Cell Res* 2002;15(1):62–6.
14. Westerhof W, d'Ischia M. Vitiligo puzzle: The pieces fall in place. *Pigment Cell Res* 2007;20(5):345–59.
15. Chaudhri G, Clark IA, Hunt NH, Cowden WB, Ceredig R. Effect of antioxidants on primary alloantigen-induced T cell activation and proliferation. *J Immunol* 1986;137(8):2646–52.
16. Salem MM, Shalhaf M, Gibbons NC, Chavan B, Thornton JM, Schallreuter KU. Enhanced DNA binding capacity on up-regulated epidermal wild-type p53 in vitiligo by H2O2-mediated oxidation: A possible repair mechanism for DNA damage. *Faseb J* 2009;23(11):3790–807.
17. Giovannelli L, Bellandi S, Pitozzi V, Fabbri P, Dolara P, Moretti S. Increased oxidative DNA damage in mononuclear leukocytes in vitiligo. *Mutation Research/Fundamental and Molecular Mechanisms of Mutagenesis* 2004;556(1–2):101–6.
18. Abu Tahir M, Pramod K, Ansari SH, Ali J. Current remedies for vitiligo. *Autoimmun Rev* 2010;9(7):516–20.
19. Felsten LM, Alikhan A, Petronic-Rosic V. Vitiligo: A comprehensive overview Part II: Treatment options and approach to treatment. *J Am Acad Dermatol* 2011;65(3):493–514.
20. Nordlund JJ, Halder R. Melagenina. An analysis of published and other available data. *Dermatologica* 1990;181(1):1–4.
21. Szczurko O, Shear N, Taddio A, Boon H. *Ginkgo biloba* for the treatment of vitiligo vulgaris: An open label pilot clinical trial. *BMC Complement Altern Med* 2011;11(21):1472–6882.
22. Xu AE, Wei XD. Topical melagenine for repigmentation in twenty-two child patients with vitiligo on the scalp. *Chin Med J* 2004;117(2):199–201.
23. Suite M, Quamina DB. Treatment of vitiligo with topical melagenine—A human placental extract. *J Am Acad Dermatol* 1991;24(6 Pt 1):1018–9.
24. Bordere AC, Lambert J, van Geel N. Current and emerging therapy for the management of vitiligo. *Clin Cosmet Investig Dermatol* 2009;2:15–25.
25. Lotti T, Berti S, Moretti S. Vitiligo therapy. *Expert Opin Pharmacother* 2009;10(17):2779–85.
26. Narahari SR, Ryan TJ, Bose KS, Prasanna KS, Aggithaya GM. Integrating modern dermatology and Ayurveda in the treatment of vitiligo and lymphedema in India. *Int. J. Dermatol* 2011;50(3):310–34.
27. Birlea SA, Costin GE, Norris DA. New insights on therapy with vitamin D analogs targeting the intracellular pathways that control repigmentation in human vitiligo. *Med Res Rev* 2009;29(3):514–46.
28. Alghamdi K, Kumar A, Moussa N. The role of vitamin D in melanogenesis with an emphasis on vitiligo. *Indian J Dermatol Venereol Leprol* 2013;79(6):750–8.
29. Minder EI. Afamelanotide, an agonistic analog of alpha-melanocyte-stimulating hormone, in dermal phototoxicity of erythropoietic protoporphyria. *Expert Opin Investig Drugs* 2010;19(12):1591–602.

30. Haylett AK, Nie Z, Brownrigg M, Taylor R, Rhodes LE. Systemic photoprotection in solar urticaria with α -melanocyte-stimulating hormone analogue [Nle4-d-Phe7]- α -MSH. *Br J Dermatol* 2011;164(2):407–14.
31. Grimes PE, Hamzavi I, Lebwohl M, Ortonne JP, Lim HW. The efficacy of afamelanotide and narrowband UV-B phototherapy for repigmentation of vitiligo. *JAMA Dermatol* 2013;149(1):68–73.
32. Le Poole IC, van den Wijngaard RM, Westerhof W, Dutrieux RP, Das PK. Presence or absence of melanocytes in vitiligo lesions: An immunohistochemical investigation. *J Invest Dermatol* 1993;100(6):816–22.
33. Nordlund JJ, Ortonne J-P. Vitiligo and depigmentation. *Current Problems in Dermatology* 1992;4(1):5–30.
34. Tobin DJ, Swanson NN, Pittelkow MR, Peters EM, Schallreuter KU. Melanocytes are not absent in lesional skin of long duration vitiligo. *J Pathol* 2000;191(4):407–16.
35. Bhawan J, Bhutani LK. Keratinocyte damage in vitiligo. *J Cutan Pathol* 1983;10(3):207–12.
36. Boissy RE, Manga P. On the etiology of contact/occupational vitiligo. *Pigment Cell Res* 2004;17(3):208–14.
37. Maresca V, Roccella M, Roccella F et al. Increased sensitivity to peroxidative agents as a possible pathogenic factor of melanocyte damage in vitiligo. *J Invest Dermatol* 1997;109(3):310–3.
38. Moellmann G, Klein-Angerer S, Scollay DA, Nordlund JJ, Lerner AB. Extracellular granular material and degeneration of keratinocytes in the normally pigmented epidermis of patients with vitiligo. *J Invest Dermatol* 1982;79(5):321–30.
39. Yohn JJ, Norris DA, Yrastorza DG et al. Disparate antioxidant enzyme activities in cultured human cutaneous fibroblasts, keratinocytes, and melanocytes. *J Invest Dermatol* 1991;97(3):405–9.
40. Schallreuter KU. Successful treatment of oxidative stress in vitiligo. *Skin Pharmacol Appl Skin Physiol* 1999;12(3):132–8.
41. Schallreuter KU, Elwary SM, Gibbons NC, Rokos H, Wood JM. Activation/deactivation of acetylcholinesterase by H_2O_2 : More evidence for oxidative stress in vitiligo. *Biochem Biophys Res Commun* 2004;315(2):502–8.
42. Schallreuter KU, Wood JM, Berger J. Low catalase levels in the epidermis of patients with vitiligo. *J Invest Dermatol* 1991;97(6):1081–5.
43. Darr D, Fridovich I. Free radicals in cutaneous biology. *J Invest Dermatol* 1994;102(5):671–5.
44. Moretti S, Spallanzani A, Amato L et al. New insights into the pathogenesis of vitiligo: Imbalance of epidermal cytokines at sites of lesions. *Pigment Cell Res* 2002;15(2):87–92.
45. Schallreuter KU, Moore J, Behrens-Williams S, Panske A, Harari M. Rapid initiation of repigmentation in vitiligo with Dead Sea climatotherapy in combination with pseudocatalase (PC-KUS). *Int J Dermatol* 2002;41(8):482–7.
46. Schallreuter KU, Wood JM, Pittelkow MR et al. Increased monoamine oxidase A activity in the epidermis of patients with vitiligo. *Arch Dermatol Res* 1996;288(1):14–8.
47. Schallreuter KU, Wood JM, Pittelkow MR et al. Regulation of melanin biosynthesis in the human epidermis by tetrahydrobiopterin. *Science* 1994;263(5152):1444–6.
48. Wong GH, Goeddel DV. Induction of manganous superoxide dismutase by tumor necrosis factor: Possible protective mechanism. *Science* 1988;242(4880):941–4.
49. Spencer JD, Gibbons NC, Rokos H et al. Oxidative stress via hydrogen peroxide affects proopiomelanocortin peptides directly in the epidermis of patients with vitiligo. *J Invest Dermatol* 2007;127(2):411–20.
50. Bakis-Petsoglou S, Le Guay JL, Wittal R. A randomized, double-blinded, placebo-controlled trial of pseudocatalase cream and narrowband ultraviolet B in the treatment of vitiligo. *Br J Dermatol* 2009;161(4):910–7.
51. Schallreuter KU, Wood JM, Lemke KR, Levenig C. Treatment of vitiligo with a topical application of pseudocatalase and calcium in combination with short-term UVB exposure: A case study on 33 patients. *Dermatology* 1995;190(3):223–9.
52. Schallreuter KU, Moore J, Wood JM et al. *In vivo* and *in vitro* evidence for hydrogen peroxide (H_2O_2) accumulation in the epidermis of patients with vitiligo and its successful removal by a UVB-activated pseudocatalase. *J Invest Dermatol Symp Proc* 1999;4(1):91–6.
53. Schallreuter KU, Moore J, Wood JM et al. Epidermal H_2O_2 accumulation alters tetrahydrobiopterin (6BH4) recycling in vitiligo: Identification of a general mechanism in regulation of all 6BH4-dependent processes? *J Invest Dermatol* 2001;116(1):167–74.

54. Medrano EE, Nordlund JJ. Successful culture of adult human melanocytes obtained from normal and vitiligo donors. *J Invest Dermatol* Oct 1990;95(4):441–5.
55. Schallreuter KU, Kruger C, Wurfel BA, Panske A, Wood JM. From basic research to the bedside: Efficacy of topical treatment with pseudocatalase PC-KUS in 71 children with vitiligo. *Int J Dermatol* 2008;47(7):743–53.
56. Schallreuter KU. Effectiveness of pseudocatalase formulations in vitiligo. *Clin Exp Dermatol* Sep 2003;28(5):562–3; author reply 563.
57. Njoo MD, Bos JD, Westerhof W. Treatment of generalized vitiligo in children with narrow-band (TL-01) UVB radiation therapy. *J Am Acad Dermatol* 2000;42(2 Pt 1):245–53.
58. Scherschun L, Kim JJ, Lim HW. Narrow-band ultraviolet B is a useful and well-tolerated treatment for vitiligo. *J Am Acad Dermatol* 2001;44(6):999–1003.
59. Tjioe M, Gerritsen MJ, Juhlin L, van de Kerkhof PC. Treatment of vitiligo vulgaris with narrow band UVB (311 nm) for one year and the effect of addition of folic acid and vitamin B12. *Acta Derm Venereol* 2002;82(5):369–72.
60. Even-Paz Z, Shani J. The Dead Sea and psoriasis. Historical and geographic background. *Int J Dermatol* 1989;28(1):1–9.
61. Shani J, Seidl V, Hristakieva E et al. Indications, contraindications and possible side-effects of climato-therapy at the Dead-Sea. *Int J Dermatol* 1997;36(7):481–92.
62. Abels DJ, Rose T, Bearman JE. Treatment of psoriasis at a Dead Sea dermatology clinic. *Int J Dermatol* 1995;34(2):134–7.
63. Boer J, Schothorst AA, Boom B, Hermans J, Suurmond D. Influence of water and salt solutions on UVB irradiation of normal skin and psoriasis. *Arch Dermatol Res* 1982;273(3–4):247–59.
64. Harari M, Shani J. Demographic evaluation of successful antipsoriatic climatotherapy at the Dead Sea (Israel) DMZ Clinic. *Int J Dermatol* 1997;36(4):304–8.
65. Westerhof W, Nieuweboer-Krobotova L. Treatment of vitiligo with UV-B radiation vs topical psoralen plus UV-A. *Arch Dermatol* 1997;133(12):1525–8.
66. Wiedow O, Wiese F, Streit V, Kalm C, Christophers E. Lesional elastase activity in psoriasis, contact dermatitis, and atopic dermatitis. *J Invest Dermatol* 1992;99(3):306–9.
67. Reuter J, Wolffe U, Korting HC, Schempp C. Which plant for which skin disease? Part 2: Dermatophytes, chronic venous insufficiency, photoprotection, actinic keratoses, vitiligo, hair loss, cosmetic indications. *J Dtsch Dermatol Ges* 2010;8(11):866–73.
68. Alcaraz MV, Pathak MA, Rius F, Kollias N, Gonzalez S. An extract of *Polypodium leucotomos* appears to minimize certain photoaging changes in a hairless albino mouse animal model. A pilot study. *Photodermatol Photoimmunol Photomed* 1999;15(3–4):120–6.
69. Bernd A, Ramirez-Bosca A, Huber H et al. *In vitro* studies on the immunomodulating effects of *Polypodium leucotomos* extract on human leukocyte fractions. *Arzneimittelforschung* 1995;45(8):901–4.
70. Fernandez-Novoa L, Alvarez XA, Sempere JM et al. Effects of anapsos on the activity of the enzyme Cu-Zn-superoxide dismutase in an animal model of neuronal degeneration. *Methods Find Exp Clin Pharmacol* 1997;19(2):99–106.
71. Gonzalez S, Alcaraz MV, Cuevas J et al. An extract of the fern *Polypodium leucotomos* (Difur) modulates Th1/Th2 cytokines balance *in vitro* and appears to exhibit anti-angiogenic activities *in vivo*: Pathogenic relationships and therapeutic implications. *Anticancer Res* 2000;20(3A):1567–75.
72. Gonzalez S, Pathak MA, Cuevas J, Villarrubia VG, Fitzpatrick TB. Topical or oral administration with an extract of *Polypodium leucotomos* prevents acute sunburn and psoralen-induced phototoxic reactions as well as depletion of Langerhans cells in human skin. *Photodermatol Photoimmunol Photomed* 1997;13(1–2):50–60.
73. Moysan A, Marquis I, Gaboriau F et al. Ultraviolet A-induced lipid peroxidation and antioxidant defense systems in cultured human skin fibroblasts. *J Invest Dermatol* 1993;100(5):692–8.
74. Philips N, Smith J, Keller T, Gonzalez S. Predominant effects of *Polypodium leucotomos* on membrane integrity, lipid peroxidation, and expression of elastin and matrixmetalloproteinase-1 in ultraviolet radiation exposed fibroblasts, and keratinocytes. *J Dermatol Sci* 2003;32(1):1–9.
75. Middelkamp-Hup MA, Pathak MA, Parrado C et al. Orally administered *Polypodium leucotomos* extract decreases psoralen-UVA-induced phototoxicity, pigmentation, and damage of human skin. *J Am Acad Dermatol* Jan 2004;50(1):41–9.

76. Middelkamp-Hup MA, Pathak MA, Parrado C et al. Oral *Polypodium leucotomos* extract decreases ultraviolet-induced damage of human skin. *J Am Acad Dermatol* 2004;51(6):910–8.
77. Goukassian DA, Gilchrist BA. The interdependence of skin aging, skin cancer, and DNA repair capacity: A novel perspective with therapeutic implications. *Rejuvenation Res* 2004;7(3):175–85.
78. Marwaha V, Chen YH, Helms E et al. T-oligo treatment decreases constitutive and UVB-induced COX-2 levels through p53- and NFkappaB-dependent repression of the COX-2 promoter. *J Biol Chem* 2005;280(37):32379–88.
79. Rundhaug JE, Mikulec C, Pavone A, Fischer SM. A role for cyclooxygenase-2 in ultraviolet light-induced skin carcinogenesis. *Mol Carcinog* 2007;46(8):692–8.
80. Tripp CS, Blomme EA, Chinn KS et al. Epidermal COX-2 induction following ultraviolet irradiation: Suggested mechanism for the role of COX-2 inhibition in photoprotection. *J Invest Dermatol* 2003;121(4):853–61.
81. Fischer SM. Is cyclooxygenase-2 important in skin carcinogenesis? *J Environ Pathol Toxicol Oncol* 2002;21(2):183–91.
82. Fischer SM, Lo HH, Gordon GB et al. Chemopreventive activity of celecoxib, a specific cyclooxygenase-2 inhibitor, and indomethacin against ultraviolet light-induced skin carcinogenesis. *Mol Carcinog* 1999;25(4):231–40.
83. Pentland AP. Cyclooxygenase inhibitors for skin cancer prevention: Are they beneficial enough? *Arch Dermatol* 2002;138(6):823–4.
84. Pentland AP, Schoggins JW, Scott GA, Khan KN, Han R. Reduction of UV-induced skin tumors in hairless mice by selective COX-2 inhibition. *Carcinogenesis* 1999;20(10):1939–44.
85. Dajani EZ, Islam K. Cardiovascular and gastrointestinal toxicity of selective cyclo-oxygenase-2 inhibitors in man. *J Physiol Pharmacol* 2008;59(Suppl 2):117–33.
86. Fosbol EL, Gislason GH, Jacobsen S et al. Risk of myocardial infarction and death associated with the use of nonsteroidal anti-inflammatory drugs (NSAIDs) among healthy individuals: A nationwide cohort study. *Clin Pharmacol Ther* 2009;85(2):190–7.
87. Lapane KL, Spooner JJ, Pettitt D. The effect of nonsteroidal anti-inflammatory drugs on the use of gastroprotective medication in people with arthritis. *Am J Manag Care* 2001;7(4):402–8.
88. Gallo O, Schiavone N, Papucci L et al. Down-regulation of nitric oxide synthase-2 and cyclooxygenase-2 pathways by p53 in squamous cell carcinoma. *Am J Pathol* 2003;163(2):723–32.
89. Kastan MB. Wild-type p53: Tumors can't stand it. *Cell* 9 2007;128(5):837–40.
90. Nishigori C. Cellular aspects of photocarcinogenesis. *Photochem Photobiol Sci* 2006;5(2):208–14.
91. Smith ML, Fornace AJ, Jr. p53-mediated protective responses to UV irradiation. *Proc Natl Acad Sci U S A* 1997;94(23):12255–7.
92. Subbaramaiah K, Altorki N, Chung WJ et al. Inhibition of cyclooxygenase-2 gene expression by p53. *J Biol Chem* 1999;274(16):10911–5.
93. You YH, Szabo PE, Pfeifer GP. Cyclobutane pyrimidine dimers form preferentially at the major p53 mutational hotspot in UVB-induced mouse skin tumors. *Carcinogenesis* 2000;21(11):2113–7.
94. Zattra E, Coleman C, Arad S et al. *Polypodium leucotomos* extract decreases UV-induced Cox-2 expression and inflammation, enhances DNA repair, and decreases mutagenesis in hairless mice. *Am J Pathol* 2009;175(5):1952–61.
95. Djavaheiri-Mergny M, Mergny JL, Bertrand F et al. Ultraviolet-A induces activation of AP-1 in cultured human keratinocytes. *FEBS Lett* 1996;384(1):92–6.
96. Gonzalez S, Alonso-Lebrero JL, Del Rio R, Jaen P. *Polypodium leucotomos* extract: A nutraceutical with photoprotective properties. *Drugs Today (Barc)* 2007;43(7):475–85.
97. Scharffetter K, Wlaschek M, Hogg A et al. UVA irradiation induces collagenase in human dermal fibroblasts *in vitro* and *in vivo*. *Arch Dermatol Res* 1991;283(8):506–11.
98. Petersen MJ, Hansen C, Craig S. Ultraviolet A irradiation stimulates collagenase production in cultured human fibroblasts. *J Invest Dermatol* 1992;99(4):440–4.
99. Scharffetter-Kochanek K, Brenneisen P, Wenk J et al. Photoaging of the skin from phenotype to mechanisms. *Exp Gerontol* 2000;35(3):307–16.
100. Janczyk A, Garcia-Lopez MA, Fernandez-Penas P et al. A *Polypodium leucotomos* extract inhibits solar-simulated radiation-induced TNF-alpha and iNOS expression, transcriptional activation and apoptosis. *Exp Dermatol* 2007;16(10):823–9.

101. Seo JY, Kim EK, Lee SH et al. Enhanced expression of cyclooxygenase-2 by UV in aged human skin *in vivo*. *Mech Ageing Dev* 2003;124(8–9):903–10.
102. McCord JM. Oxygen-derived free radicals in postischemic tissue injury. *N Engl J Med* 1985;312(3):159–63.
103. Tedesco AC, Martinez L, Gonzalez S. Photochemistry and photobiology of actinic erythema: Defensive and reparative cutaneous mechanisms. *Braz J Med Biol Res* 1997;30(5):561–75.
104. Gonzalez S, Pathak MA. Inhibition of ultraviolet-induced formation of reactive oxygen species, lipid peroxidation, erythema and skin photosensitization by *Polypodium leucotomos*. *Photodermatol Photoimmunol Photomed* 1996;12(2):45–56.
105. Chapple IL. Reactive oxygen species and antioxidants in inflammatory diseases. *J Clin Periodontol* 1997;24(5):287–96.
106. Gomes AJ, Lunardi CN, Gonzalez S, Tedesco AC. The antioxidant action of *Polypodium leucotomos* extract and kojic acid: Reactions with reactive oxygen species. *Braz J Med Biol Res* 2001;34(11):1487–94.
107. Kong Q, Lillehei KO. Antioxidant inhibitors for cancer therapy. *Med Hypotheses* 1998;51(5):405–9.
108. Singh K. Oxidants, antioxidants and diseases—A brief review. *Indian J Med Sci* 1997;51(7):226–30.
109. Peak MJ, Peak JG. Solar-ultraviolet-induced damage to DNA. *Photodermatol* 1989;6(1):1–5.
110. Petersen M, Hamilton T, Li HL. Regulation and inhibition of collagenase expression by long-wavelength ultraviolet radiation in cultured human skin fibroblasts. *Photochem Photobiol* 1995;62(3):444–8.
111. Wlaschek M, Briviba K, Stricklin GP, Sies H, Scharffetter-Kochanek K. Singlet oxygen may mediate the ultraviolet A-induced synthesis of interstitial collagenase. *J Invest Dermatol* 1995;104(2):194–8.
112. Wlaschek M, Heinen G, Poswig A et al. UVA-induced autocrine stimulation of fibroblast-derived collagenase/MMP-1 by interrelated loops of interleukin-1 and interleukin-6. *Photochem Photobiol* 1994;59(5):550–6.
113. Wlaschek M, Wenk J, Brenneisen P et al. Singlet oxygen is an early intermediate in cytokine-dependent ultraviolet-A induction of interstitial collagenase in human dermal fibroblasts *in vitro*. *FEBS Lett* 1997;413(2):239–42.
114. Brieva A, Guerrero A, Pivel J. Immunomodulatory properties of a hydrophilic extract of *Polypodium leucotomos*. *Inflammopharmacology* 2001;9(4):361–71.
115. Fearon DT, Locksley RM. The instructive role of innate immunity in the acquired immune response. *Science* 1996;272(5258):50–3.
116. Garside P, Mowat AM. Polarization of Th-cell responses: A phylogenetic consequence of nonspecific immune defence? *Immunol Today* 1995;16(5):220–3.
117. Mosmann TR, Coffman RL. TH1 and TH2 cells: Different patterns of lymphokine secretion lead to different functional properties. *Annu Rev Immunol* 1989;7:145–73.
118. Romagnani S. Induction of TH1 and TH2 responses: A key role for the ‘natural’ immune response? *Immunol Today* 1992;13(10):379–81.
119. Rayward J, Villarrubia VG, Guillen C et al. An extract of the fern *Polypodium leucotomos* inhibits human peripheral blood mononuclear cells proliferation *in vitro*. *Int J Immunopharmacol* 1997;19(1):9–14.
120. Gately MK, Renzetti LM, Magram J et al. The interleukin-12/interleukin-12-receptor system: Role in normal and pathologic immune responses. *Annu Rev Immunol* 1998;16:495–521.
121. Trinchieri G. Interleukin-12: A proinflammatory cytokine with immunoregulatory functions that bridge innate resistance and antigen-specific adaptive immunity. *Annu Rev Immunol* 1995;13:251–76.
122. Mohammad A. Vitiligo repigmentation with Anapsos (*Polypodium leucotomos*). *Int J Dermatol* 1989;28(7):479.
123. Middelkamp-Hup MA, Bos JD, Rius-Diaz F, Gonzalez S, Westerhof W. Treatment of vitiligo vulgaris with narrow-band UVB and oral *Polypodium leucotomos* extract: A randomized double-blind placebo-controlled study. *J Eur Acad Dermatol Venereol* 2007;21(7):942–50.
124. Passi S, Grandinetti M, Maggio F, Stancato A, De Luca C. Epidermal oxidative stress in vitiligo. *Pigment Cell Res* 1998;11(2):81–5.
125. Dell’Anna ML, Mastrofrancesco A, Sala R et al. Antioxidants and narrow band-UVB in the treatment of vitiligo: A double-blind placebo controlled trial. *Clin Exp Dermatol* 2007;32(6):631–6.
126. Bojunga J, Dresar-Mayert B, Usadel KH, Kusterer K, Zeuzem S. Antioxidative treatment reverses imbalances of nitric oxide synthase isoform expression and attenuates tissue-cGMP activation in diabetic rats. *Biochem Biophys Res Commun* 2004;316(3):771–80.

127. Liu J, Killilea DW, Ames BN. Age-associated mitochondrial oxidative decay: Improvement of carnitine acetyltransferase substrate-binding affinity and activity in brain by feeding old rats acetyl-L-carnitine and/or R-alpha -lipoic acid. *Proc Natl Acad Sci U S A* 2002;99(4):1876–81.
128. Maritim AC, Sanders RA, Watkins JB, 3rd. Effects of alpha-lipoic acid on biomarkers of oxidative stress in streptozotocin-induced diabetic rats. *J Nutr Biochem* 2003;14(5):288–94.
129. Tomita Y, Iwamoto M, Masuda T, Tagami H. Stimulatory effect of prostaglandin E2 on the configuration of normal human melanocytes in vitro. *J Invest Dermatol* 1987;89(3):299–301.
130. Nordlund JJ, Collins CE, Rheins LA. Prostaglandin E2 and D2 but not MSH stimulate the proliferation of pigment cells in the pinnal epidermis of the DBA/2 mouse. *J Invest Dermatol* 1986;86(4):433–7.
131. Parsad D, Pandhi R, Dogra S, Kumar B. Topical prostaglandin analog (PGE2) in vitiligo—A preliminary study. *Int J Dermatol* 2002;41(12):942–5.
132. Sauk JJ, Jr., White JG, Witkop CJ, Jr. Influence of prostaglandins E1, E2, and arachidonate on melanosomes in melanocytes and keratinocytes of anagen hair bulbs in vitro. *J Invest Dermatol* 1975;64(5):332–7.
133. Prota G, Vincensi MR, Napolitano A, Selen G, Stjernschantz J. Latanoprost stimulates eumelanogenesis in iridial melanocytes of cynomolgus monkeys. *Pigment Cell Res* 2000;13(3):147–50.
134. Moore TC, Spruck CH, Lami JL, Said SI. Prompt elevations of PGE2 and thromboxane A2 metabolites in peripheral node efferent lymph of sheep following drainage area immunization. *Immunopharmacol* 1989;17(2):73–80.
135. Henke PK, Bergamini TM, Brittian KR, Polk HC, Jr. Prostaglandin E2 modulates monocyte MHC-II (Ia) suppression in biomaterial infection. *J Surg Res* 1997;69(2):372–8.
136. Teschke R, Bahre R. Severe hepatotoxicity by Indian Ayurvedic herbal products: A structured causality assessment. *Ann Hepatol* 2009;8(3):258–66.
137. Genuis SJ, Schwalfenberg G, Siy AK, Rodushkin I. Toxic element contamination of natural health products and pharmaceutical preparations. *PLoS One* 2012;7(11):21.
138. Szczurko O, Boon HS. A systematic review of natural health product treatment for vitiligo. *BMC Dermatol* 2008;8(2):1471–5945.
139. Antiviteligo—Herbal treatment for repigmentation of vitiligo. <http://www.antiviteligo.com/vitiligo-cure/index.html>.
140. Faas L, Venkatasamy R, Hider RC, Young AR, Soumyanath A. *In vivo* evaluation of piperine and synthetic analogues as potential treatments for vitiligo using a sparsely pigmented mouse model. *Br J Dermatol* 2008;158(5):941–50.
141. Ichimiya M. Immunohistochemical study of ACTH and alpha-MSH in vitiligo patients successfully treated with a sex steroid–thyroid hormone mixture. *J Dermatol* 1999;26(8):502–6.
142. Muto M, Furumoto H, Ohmura A, Asagami C. Successful treatment of vitiligo with a sex steroid–thyroid hormone mixture. *J Dermatol* 1995;22(10):770–2.
143. Siddiqui AH, Stolk LM, Bhaggoe R et al. L-phenylalanine and UVA irradiation in the treatment of vitiligo. *Dermatology* 1994;188(3):215–8.
144. Zhao D, Li Y, Wang P et al. Melagenine modulates proliferation and differentiation of melanoblasts. *Int J Mol Med* 2008;22(2):193–7.
145. Whitton ME, Pinart M, Batchelor J, Leonardi-Bee J, González U, Jiyad Z, Eleftheriadou V, Ezzedine K. Interventions for vitiligo. *Cochrane Database Syst Rev* 2015 Feb 24;2:CD003263.
146. Shapiro SS, Saliou C. Role of vitamins in skin care. *Nutrition* 2001;17(10):839–44.
147. Lapenna D, Ciofani G, Pierdomenico SD, Giamberardino MA, Cuccurullo F. Dihydrolipoic acid inhibits 15-lipoxygenase-dependent lipid peroxidation. *Free Radic Biol Med* 2003;35(10):1203–9.
148. Pocernich CB, Butterfield DA. Acrolein inhibits NADH-linked mitochondrial enzyme activity: Implications for Alzheimer’s disease. *Neurotox Res* 2003;5(7):515–20.

Alain Khaiat and Claude Saliou

Introduction

The existence of the word “cosmeceuticals” is very much linked to the U.S. Food and Drug Administration (FDA) definition of drugs and cosmetics in the 1938 Food Drug and Cosmetic (FD&C) Act, although this term does not have a legal standing. One can only speculate as to why 75 years of scientific knowledge and research have been ignored by the FDA in not revising the definition! The European Commission has revised, and its 1976 definition of cosmetics was modified in 1993 to acknowledge the fact that everything put on the skin or hair may have a physiological effect.¹ This definition still holds in the Cosmetic Directive amended in 2003² and the Cosmetic Regulation published in 2009.³ It puts the responsibility on the industry to ascertain product safety and efficacy (claims justification).⁴

Natural ingredients, whether from animal, botanical, microbiological, or mineral origin, have been used as “active ingredients” for drugs and cosmetics for as long as human history. Oils, butters, honey, beeswax, oatmeal, citrus juice, and even lead were common ingredients of the beauty recipes from ancient Egypt.⁵ Many botanical extracts are used today in traditional medicine, and large pharmaceutical companies are rediscovering them.⁶

The major differences between the drug and the cosmetic approach rely on the intent (i.e., “cure or prevention of a disease” vs. “beautifying” and “improving the appearance”), as well as how the extract is considered. In the cosmetic industry, the botanical extract is the active ingredient. It may contain hundreds of chemical structures and it has a proven activity. Historically in the drug industry, the knowledge of the chemical structure of the active ingredient within the extract was required to enable its further synthesis and purification. At times, this approach led to a total loss of the biological activity, or the realization that, despite all the skills of organic chemists, nature is not easy to reproduce.⁷ Considering this caveat and also that some complex natural mixtures (i.e., extracts) were extensively used in traditional medicines, in June 2004 the U.S. FDA crafted a guidance document for the industry to present the various options on how to bring a botanical product to the market and, more importantly, on how to submit a new drug application for a botanical extract.⁸ Two botanical drugs have since been approved. The first one, in 2006, is a partially purified green tea extract (Sin catechins), consisting of 85%–95% catechins (at least 55% being epigallocatechin gallate) for the topical treatment of genital warts.^{9,10} The second one, approved at the end of 2012, is an extract from the latex of *Croton lechleri*, consisting of proanthocyanidins (oligomers of catechins), for the treatment of diarrhea in HIV/AIDS patients.^{11,12} These first two approved botanical drugs are important as they exemplified the need to consider botanical extracts as complex mixtures for the treatment or prevention of diseases otherwise difficult to manage. Many other botanical extracts are currently on a drug development track in various stages of clinical testing.¹³

Origin of Botanical Extracts

Botanical extracts have been used for centuries. They are present in today’s products either for their own properties and benefits, or as a replacement for animal materials that may have to be removed from products because of the pressure of animal rights associations or the potential disease risks, like bovine

spongiform encephalopathy (BSE). Moreover, in the last 15 years, botanical extracts have increasingly been used in cosmetics to replace petrochemical ingredients, although not always successfully reproducing product esthetics, texture, or efficacy. Consequently, many ingredients used in cosmetics are natural ingredients that are chemically modified to provide the desired range of properties (e.g., lauric acid, extracted from coconut or palm kernel oil, is reduced to lauryl alcohol, which is sulfated to produce sodium lauryl sulfate).

Botanicals are eukaryotic organisms comprising terrestrial and aquatic plants (e.g., grasses, trees, shrubs, and seaweeds) and fungi (e.g., yeasts and edible mushrooms). Botanical materials used in cosmetic products come in a variety of forms: plant powders, botanical extracts, and biotechnology extracts.

- Although botanical extracts are the main focus of this chapter, it is important to mention *dried plant powders*. This category of botanical materials is important, as they are the origin of the use of botanicals in cosmetic products. Dried plant powders are particularly used in traditional medicine (e.g., Ayurveda and traditional Chinese medicine). Plant powders are also commonly used in color cosmetics (e.g., saffron from *Crocus sativus*), for hair coloring (henna and chamomile), scrubs (apricot kernel, ground walnut shell, corn), or masks (oat flour, turmeric, cocoa).¹⁴
- Today, *botanical extracts* are the most popular form of botanical materials used in cosmetic products. They are obtained after some processing of the botanical material. This processing often involves a solvent extraction with the objective to purify a certain part or constituent of the plant, to remove certain substances from the plant, or to solubilize others. Botanical extracts are also more easily blended into topical product than plant powders.
- Lastly, *biotechnology extracts* are obtained through fermentation, genetic engineering, or soil-less culture (hydroponic culture, cell culture suspension in artificial media, etc.). They are developed from microorganisms, plant organs, total plants, or through the use of specific enzymes.¹⁵ Biotechnology extracts have evolved from the traditional fermentation processes to include genetic engineering of microorganisms to produce renewable chemical building blocks (e.g., fatty acids, succinic acid, glycerol).^{16,17}

In contrast to a synthesized chemical, where a single chemical entity is produced with a defined structure, a botanical extract is a complex, largely undefined mixture resulting from a natural and only partially controlled process. The actual origin (also called here “biomass”) of a botanical material is critical to the identity and quality of the resulting botanical extract. In fact, the cultivation and harvesting methods must be thoroughly monitored to assure the appropriate biomass is obtained and avoid contaminations with other plants. Variations in the biomass quality due to seasonal, geographical, and harvest differences are common and must be mitigated through a standardization process during the extraction process whenever possible.

While extract standardization based on specific phytochemical markers is important and often possible, it can only account for a minor part of the extract, leaving a large part of the extract open to both natural variations and unfortunately adulterations too.¹⁸ For instance, virgin coconut oil may be adulterated with lower value vegetable oils like palm kernel oil or even mineral oil.¹⁹ Black Cohosh (*Actaea racemosa*) extract contamination is relatively common and well reported. In this instance, plant parts from other *Actaea* species are mistakenly collected and extracted, resulting in the presence of potentially toxic compounds.^{20,21}

Botanical extracts suppliers can use a variety of analytical techniques to prevent such issues and to validate the authenticity and identity of the botanical extracts they supply. These may include thin layer chromatography or other chromatographic fingerprinting techniques⁸ and carbon dating²² to rule out petrochemicals from botanical extracts.

Suppliers of botanical extracts and manufacturers of botanical extract-containing products must use caution as to how the original botanical material has been obtained in view of the convention for biological diversity and the Access and Benefit Sharing (ABS) regulations now in place in many botanical material-rich countries (e.g., Brazil). Claims of biopiracy have come up against companies patenting certain botanical extracts or marketing products containing them.^{23–25}

Extraction Process

Active ingredients are not present in equal amounts throughout the plant or the organism. Most of the time, a higher concentration can be found in certain plant parts or organelles. Therefore, it is usually only one part of the plant that is used: fruits, seeds, bark, roots, buds, leaves, flowers, etc.

A typical industrial process to produce natural extracts may include one or several of the following steps: drying of the harvested biomass (e.g., plant part), extraction, filtration, concentration, and lyophilization.

Depending on the future use of the extract, various extraction processes can be used. As mentioned, it is industry's responsibility to ensure the absence of toxic substances that could lead to unwanted side effects. The drug approval process allows side effects to be present provided the benefits outweigh the disadvantages, while the cosmetics consumer has the choice of using a product that may have side effects or using another that has none; the product with side effects would not be acceptable. The choice of the extraction process will be determined by several criteria: the botanical material itself, the intended composition (and potential function) and its level of characterization, and the expected final cost of the extract.

Total Extracts

Total extracts are the most common in the cosmetics industry, but rarely, if ever, used in drugs. They are generally known from traditional usage. Their activity is often empirical and their active ingredients are not always identified, but their benefits are, very often, without possible doubt. Their mode of preparation can be found in traditional pharmacopeias (China, India, Africa, Europe, America), or from observing shamans or traditional practitioners. In many cases, plant extracts are blended in order to better control or synergize their effects, but sometimes also to preserve the secret of the active ingredient.

Modern techniques include: (a) pressing—for plants rich in water (e.g., juice, fresh plants, fruits, vegetables, cactus, aloe) or oil (e.g., olive, sunflower seed, soybean); (b) percolation, with one solvent or a mixture of solvents (water, glycols, ethanol) at room temperature or at elevated temperature (this process is the same as the one used to obtain coffee); and (c) maceration, with the same type of solvents (this process is the same as the one used to obtain tea).

The composition of the extract is, however, very much a function of the type of solvent, the temperature, the plant-to-solvent ratio, the time of contact between the plant and the solvent, the part of the plant used, and the actual plant species. Sometimes it is also dependent on the plant culture conditions, the growing location, the stage of maturity of the plant, and the season of harvest. An increasing number of ingredient suppliers are now requiring proofs of the chain of custody for the biomass used to produce the extract. The biomass chain of custody and a rigorous documentation of the extraction process (following good manufacturing practices) guarantee a better control over stability, preservation, and manufacturing reproducibility for more consistent extract batches.

Solvents have to be carefully chosen, not only for their extraction properties (dielectric constant), but also for their compatibility with the final formulation and their innocuousness.

Following the extraction process, the total extracts are passed through filters to clarify the solution and remove the remaining plant particulates. In some cases, the liquid extract will be lyophilized either by spray-drying (most common) or freeze-drying. The drying process allows a longer shelf life and sometimes also a higher concentration of extract in the finished product.

Selective Extracts

Special extraction processes or the use of specific solvents will lead to the obtention of a specific class of molecules, fractions enriched in certain compounds, or an extract depleted of unwanted compounds. While solvent extraction (also referred to as Soxhlet extraction) remains the most used method, new extraction technologies, providing better yields, consuming less energy, requiring less time and being

more environmentally friendly, are now being industrialized. These new extraction methods include accelerated or pressurized solvent extraction, supercritical fluid extraction, enzymatic extraction, ultrasonic extraction, and microwave extraction.^{26–28} These novel methods may be used as a step in a complex extraction process. For instance, enzyme-assisted extraction can be used as the first step to break down the plant tissues before performing a solvent extraction. In the case of supercritical fluid extraction, solvents like ethanol or methanol may be used to increase the yield of specific substances.

The fragrance industry has for centuries obtained essential oils or floral water by water vapor extraction or “enfleurage”—a process by which the plant flowers are put in contact with solid fats and terpenes and sesquiterpenes migrate into the oil phase.

The use of vegetable oils as solvents allows for the extraction of oil soluble vitamins or lipids. More recently the use of supercritical CO₂ extraction has been developed to efficiently extract aromas, essential oils, oleoresins, and other non-polar plant constituents without the need for low-dielectric constant solvents like hexane.²⁹

Selective standardized extracts with defined chemical fingerprints and specific molecular markers have the advantage of providing a reliable ingredient, with consistent biological activity and safety profile. However, the major drawbacks from such extracts are their cost and the loss of holistic synergies, a hallmark of total extracts. This is not to say that selective extracts do not account for any synergies. In fact, the green tea extract used as botanical drug (sin catechins) is an enriched fraction of mixed catechins working in synergy to provide collectively potent antiviral, anti-proliferative, and antioxidant properties.³⁰

Purification

Physical methods (such as filtration or centrifugation) are employed to clarify the extracts at the macroscopic level. Extract purification to separate specific molecules from others are done following classic physicochemical processes—cryoprecipitation, column chromatography, electrophoresis, ultrafiltration (for macromolecules with a specific size cutoff), use of selective solvents and salts, etc. Decolorization and deodorization of botanical extracts is often carried using activated charcoal filters. The purification step is important to maintain the chemical stability of the extract.

Biotechnology Extracts

Biotechnology can be used to obtain, purify, or transform extracts. This is one of the fastest growing ingredient categories in personal care. It includes the traditional ferments, but is now expanding into biocatalysis (enzyme-assisted chemical synthesis),³¹ plant cell cultures, and synthetic biology.

The use of enzymes as extraction and synthetic tools is expanding.^{32,33} On one hand, proteases, amylases, and ligninases break down protein, starch, and lignin matrices to enable more efficient extraction of certain phytochemicals. On the other hand, enzymes are used to synthesize ingredients as they provide stereospecificity or eliminate the risk of solvent residues. Today, protein hydrolysates obtained by enzymatic reaction are free of the chlorine residues formed when acid hydrolysis is used. Enzymes allow for better yields by transforming or releasing specific molecules from the plant matrices (use of pectinases, beta-glucosidase, beta-glucanase, lipases, transferases, esterases, etc.).

Synthetic biology, or microorganism-assisted synthesis, a tool long used in the pharmaceutical industry, is now coming to cosmetics. Microorganisms, wild type or genetically modified, now produce many ingredients used in cosmetics (e.g., hyaluronic acid, fragrances, succinic acid, propanediol, and alternative oil feedstock for surfactants).^{16,17,34,35}

Plant cell cultures are now ubiquitous. The first application of this technology was the industrial production of the oncology drug taxol, thereby avoiding the harvest of endangered yew trees. The technique is now widely used to produce cosmetic ingredients, whether they are from endangered plants or to produce low-occurring phytochemicals.³⁶ The main methodology employed consists in harvesting a plant part (e.g., plant meristem, leaf, etc.), producing a callus (undifferentiated cell mass), generating a cell suspension and either collecting the cells and drying them or performing a solvent extraction of the whole culture.³⁷

Usage and Applications

Extracts or purified botanical molecules can be used as-is (i.e., powders, tinctures) or incorporated into solutions, emulsions, or dispersions. They can be topically applied, ingested, or even injected (e.g., mesotherapy),³⁸ depending on the intended use, provided absence of toxicity has been shown.

Formulating botanical extracts in emulsions is an art, balancing the product esthetics, the activity of the extract, and the chemical stability of its constituents. The latter is a major issue for natural antioxidants. In fact, they can easily autoxidize in the presence of transition metals (e.g., iron, copper), light, and oxygen (i.e., air). The temperature and pH is also critical; ascorbic acid and some polyphenols (e.g., curcumin, verbascoside) are unstable at neutral or high pH,^{36,39} while retinol and carotenoids are unstable at low pH.⁴⁰

To overcome some of these challenges, botanical extracts can be encapsulated into liposomes, nanoparticles, phytosomes, microsponges, or oleosomes, or formulated into micro or nano-emulsions.^{41–43}

Properties

Are botanical extracts really active? How does their activity compare to that of synthetic materials? Are all natural ingredients safe?

Certainly one learns a lot about these questions by studying traditional uses. Centuries of human experience can prove safety. For example, *Lilium* bulb oil extract use for sunburns has been reported since ancient Greece, whereas the water extract has been shown to be toxic. Natural ingredients have been shown to have a broad spectrum of activity, including hallucinogenic mushrooms and cardiotoxic *Belladonna*. Scientific research conducted on plant extracts described in traditional pharmacopeias^{44,45} has led to a broader range of potential applications.

In cosmetics, botanical extracts are used to improve skin moisturization, reduce the signs of aging or cellulite, brighten and sooth the skin, and make scars less noticeable. They are also used to stabilize or preserve, thicken, and even emulsify products. Moreover, botanical extracts are coming back in drug discovery, helping to treat diseases for which pure organic chemistry has failed to deliver effective solutions.

Skin Moisture and Barrier Functions

The skin outermost layer, the stratum corneum, gives the skin its barrier function; a physical barrier against external intruders or aggressors (including pathogens, ultraviolet [UV] light, and pollutants) and a biological barrier with the means to recognize aggressions and launch appropriate responses to eliminate or isolate the damage if it occurs.⁴⁶ Botanicals can not only promote and restore a normal physical barrier, but also help the skin to fight and prepare itself against aggressions and injuries (including inflammation). Visible skin inflammation or redness can be triggered by multiple factors such as an infection (e.g., acne), exposure to sun and atmospheric pollutants (e.g., ozone), or a reaction to a cosmetic product.

Polyunsaturated fatty acids (PUFA) of the n-3 and n-6 types are essential fatty acids (EFA). Their long unsaturated carbon chains contribute to cell membrane fluidity, an enabler to cell signaling.⁴⁷ They also give the skin critical functions such as immune-modulation and structure.⁴⁸

Historically, fish oils (menhaden) were the main sources of essential fatty acids. They were particularly rich in polyunsaturated fatty acids (PUFA) of the n-3 type (also known as omega-3 or ω-3 fatty acids) (e.g., eicosapentaenoic acid [EPA] or docosapentaenoic acid [DHA]). They have anti-inflammatory and immune-modulatory activities, competing with arachidonic acid in the production of inflammatory mediators.^{48,49} EPA and DHA are now produced from microalgae cultures in photobioreactors.⁵⁰ Seed oils and other plant extracts, rich in alpha-linolenic acid (C18:3) and stearidonic acid (C18:4) (e.g., *Plukenetia volubilis*, *Linum usitatissimum* (flaxseed), *Echium plantagineum*, *Portulaca oleracea*, and *Hippophae rhamnoides*) interfere with the arachidonic acid oxidative metabolism (cyclooxygenase and lipoxygenase pathways), thereby stopping the production of pro-inflammatory eicosanoids (e.g., PGE₂,

LTB4). Moreover, long chain ω -3 PUFA (e.g., DHA and EPA) can be converted into resolvins, which help to control the inflammatory process further.⁵¹

In contrast, *Oenothera biennis* (evening primrose), *Borago officinalis* (borage), *Ribes nigrum* (black currant), and *Helianthus annuus* (Sunflower) seed oils are rich in PUFA of the n-6 type (also known as omega-6 or ω -6 fatty acids) (e.g., gamma-linolenic acid [C18:3 n-6], linoleic acid [C18-2 n-6]). Linoleic acid is one of the most abundant PUFA in the stratum corneum contributing to the maintenance and the restoration of epidermal lipids, including ceramides. Moreover, topical application of a linoleic acid-rich sunflower oil has been shown to be effective in restoring the barrier function upon disruption.⁵² In Japan, linoleic acid is a quasi-drug for skin whitening, working by accelerating the degradation of the tyrosinase enzyme in the melanosomes.⁵³ A recent study also demonstrated the positive correlation between a high linoleic acid diet and reduced signs of photoaging.⁵⁴

Many other plant oils and butters are rich in EFA⁵⁵ (mainly oleic and linoleic) (e.g., safflower, sunflower, walnut, wheat, soybean, corn, rice bran, argan, and oat oils; shea and cocoa butters) and squalane (olive oil, argan oil, and yeast oil),⁵⁶ which maintains skin suppleness and reduces water loss. Many also contain a non-saponifiable fraction rich in tocopherols, phytosterols, and phenolics. For instance, *Argania spinosa* (argan) oil is particularly rich in γ -tocopherols,⁵⁷ a vitamin E isomer known for its anti-inflammatory properties.⁵⁸

Phytosterols slow down the aging process by favoring fatty acid desaturation, which in turn maintains membrane fluidity and catalytic activity. Soybean phytosterols have been shown to promote barrier repair upon injury.⁵⁹ Topically applied gamma-oryzanol (ferulic esters of cycloartanol, cycloartenol, and β -sitosterol) extracted from rice bran, stimulates sebaceous gland activity, which slows down with age. β -Sitosterol is well known for its inflammatory and skin lightening properties.

A number of plant waxes (sugar cane, *Carnauba*, *Ceroxylon*, *Jajoba*, rose) are used to protect lips, hands, or face from dehydration, providing an occlusive effect.

Ceramides are critical constituents of the stratum corneum structure, comprising about 50% of its lipids and giving it its barrier function.⁴⁶ Certain plants (yeast, wheat, apple, potato, rice bran, *Agaricus*, *Morus alba*, or white mulberry) are rich in ceramides and glycosylceramides. These may be used for their action on skin or hair to provide hydration or reconstitute epidermal barrier function. While ceramides are challenging to deliver into the skin, some botanical extracts, such as *Eucalyptus* extract⁶⁰ or red ginseng,⁶¹ are able to stimulate their synthesis *in situ*.

Yet, certain plant extracts rich in polysaccharides, such as aloe vera extract (*Aloe barbadensis*)⁶² and Tamarind seed (*Tamarindus indica*),⁶³ are used to trap moisture in the upper layers of the stratum corneum by forming a thin film. Similarly, colloidal oatmeal, a finely ground oat kernel powder and U.S. FDA-monographed skin protectant, forms a hydro-lipid film at the surface of skin when its main constituents (proteins, starch, and lipids) are in contact with water.⁶⁴

Other constituents of botanical extracts, such as phenolics (and polyphenols), carotenoids, and terpenoids, play important roles in regulating the barrier formation and inflammation, reducing skin redness and itch.

The phenolics class of phytochemicals is among the most diverse and also richest in effective anti-inflammatory compounds. Phenolics are also potent antioxidants and will provide significant protection against oxidation in the aqueous compartments. Some of the most noteworthy phenolics are catechins (green tea), proanthocyanidins (pine bark, grape seed), avenanthramides (oat kernel), flavonoids (silymarin, quercetin), stilbenoids (resveratrol), chalcones (licochalcone in licorice extract), ferulic acid (rice), and oleuropein (olive leaf).

The sesquiterpene alpha-bisabolol (from the wood of *Eremanthus erythropappus*, Candeia, or *Matricaria recutita*, German chamomile) is commonly used for its soothing property.⁶⁵

Aging

Chronological skin aging is characterized by (a) a progressive catabolism and reduced synthesis of the skin extracellular matrix (collagen, elastin, glycosaminoglycans), leading to loss of elasticity and firmness, and fine lines and wrinkles; (b) a reduced epidermal regeneration, resulting in skin thinning and barrier disruption; (c) a heterogenous pigmentation, exhibiting hyperpigmented spots; (d) altered capillary

micro-circulation causing blotchiness; and (e) reduced cell–cell signaling and response to growth factors. These changes are accelerated by sun exposure (photo-aging), which further damage skin macromolecules (DNA, proteins, lipids) either directly or via the production of reactive oxygen species.⁶⁶

Ascorbic acid is a key element in collagen synthesis,⁶⁷ stimulating the production of both collagen I and III RNA.⁶⁸ Likewise, *Centella asiatica* (triterpene fraction—asiatic acid, asiaticoside, madecassic acid, madecassoside) stimulates synthesis of collagen (I and III) and fibronectin.^{69,70} Hydroxyproline, produced via fermentation, helps to promote collagen synthesis in dermal fibroblasts and also stabilize the triple-helix.⁷¹

Several botanical extracts, particularly those rich in condensed tannins (catechin oligomers), work by maintaining intact the extracellular matrix components and protecting them against proteolytic degradation. For instance, the proanthocyanidins from pine bark or grape seed cross-link the collagen fibers, rendering them more resistant to degradation.⁷² Other polyphenols found in blackberry leaf extract inhibit the activity of the metalloproteinase-1 (MMP-1) enzyme, responsible for the degradation of collagen-I, but also MMP-9 and elastase.⁷³ Thring et al. reported about the collagenase and elastase inhibitory activity of a dozen plant extracts; white tea, epigallocatechin gallate, and bladderwrack (a seaweed) had the highest activities.⁷⁴ Fucoidans (sulfated polysaccharides from brown seaweed *Undaria pinnatifida*) are also effective in inhibiting UVB-induced MMP-1 in fibroblasts.⁷⁵

Other extracts rich in gallotannins and ellagitannins also have antihyaluronidase activity.⁷⁶

α - or β -Hydroxy-acids have been in vogue for the last 20 years, not only in cosmetics but also in over-the-counter (OTC) drugs.⁷⁷ The main α -hydroxy acids (AHAs) are glycolic acid, lactic acid, citric acid, malic acid, and tartaric acid. While they are often called “fruit acids” due to their occurrence in fruits like apple, lemon, orange (and most fruits of the citrus genus), bilberry, and blackcurrant, they can also come from plant parts such as in *Saccharum officinalis* (sugar cane) juice (main source for glycolic acid) and *Acer saccharum* (sugar maple). β -Hydroxy-acids (BHAs) are mainly represented by salicylic acid in cosmetics and OTC drugs. Salicylic acid is extracted from the willow bark (*Salix alba* or *Salix nigra*) and wintergreen leaf oil (*Gaultheria procumbens*). AHAs and BHAs are used for skin smoothing and brightening. They contribute to the elimination of dead cells from the skin surface, hydration, as well as cell renewal in facial, body, and even scalp care. While they promote epidermal cell renewal, they have been shown to plump dermis and epidermis by stimulating the production of collagen and hyaluronic acid.⁷⁸

Botanical proteolytic enzymes are available and are effective exfoliators. One is an aspartate protease (cathepsin D) isolated from *Mucor miehei* mushroom.^{79,80} The others commonly used are papain (a cysteine protease from *Carica papaya*)⁸¹ and bromelain (from pineapple).⁸² Both papain and bromelain can induce a pruritus if their usage is not carefully controlled.⁸³

Mushrooms (e.g., *Ganoderma*, *Grifola*) are also rich in polysaccharides (beta-glucans) that exhibit immunostimulatory and immunoregulatory properties. They have been used in traditional Chinese medicine to slow down aging. It was recently demonstrated that in addition to their antioxidant properties, they also stimulate collagen synthesis by dermal fibroblasts.^{80,84} Beta-glucans are also found in oats where they constitute one of the major class of non-starch polysaccharides.⁸⁵ Oat beta-glucans have been shown effective in reducing wrinkle depth.⁸⁶

Antioxidants

Skin is continuously exposed to oxygen, oxidative insult (e.g., UV, ozone, smog, tobacco smoke, xenobiotics). Moreover, skin is composed of molecules that can be easily oxidized (unsaturated fatty acids, proteins, endogenous antioxidants). In a normal state, skin homeostasis, a balance between the endogenous antioxidants and the oxidative environment, is maintained. However, in a situation of excessive exposure to an oxidative insult (e.g., UV), the endogenous antioxidants are not sufficient to maintain this homeostasis, resulting in damage to the skin barrier (unsaturated fatty acids), proteins (collagen, elastin), and DNA, altogether affecting proper skin structure and function. Over time, these oxidative events are the triggers for many of the key changes characterizing skin aging, as well as inflammatory reactions.⁸⁷

To counteract this rather hostile environment, different strategies have been developed over the last 25 years: supplementing the skin's endogenous antioxidants (i.e., lipophilic vitamin E and carotenoids, and hydrophilic vitamin C and glutathione) or providing antioxidants with the capacity to boost or

complement the endogenous antioxidants (e.g., phenolics, thiols).^{88,89} Another strategy is also emerging out of the latter; antioxidants can specifically activate the skin's adaptive defenses, through regulators like NRF-2⁹⁰ and sirtuins.⁹¹

Most of polyunsaturated fatty acid-rich vegetable oils also contain high amounts of tocopherols (rich in tocopherols and tocotrienols). α -Tocopherol contributes directly to cell membrane structure by stabilizing it⁹² and allowing for proper functioning of membrane proteins. Soybean, rapeseed, safflower, and argan oils are also rich in γ -tocopherol. Tocopherol mixtures extracted from soybean oil are usually over 60% γ -tocopherol. γ -tocopherol is not only anti-inflammatory but also an emulsion stabilizer⁹³ and skin photoprotectant.⁹⁴ Wheat germ oil, rice bran oil, and palm oil are particularly rich in tocotrienols.⁹⁵

Carotenoids, such as β -carotene, are found in plants or in part of plants exposed to the sun, but also in non-sun-exposed plant parts (carrot, sweet potato). Of particular interest is a unicellular microalgae, *Dunaliella salina*. Under normal conditions of light, temperature, or salt, these algae are green. However, under extreme conditions (high salinity, low pH, high sunlight, lack of nitrogen or phosphorus), they protect themselves by producing large concentrations of β -carotene (and glycerol to protect against osmotic stress). The ponds become red, and the β -carotene concentration can reach 14% of the dry weight. As first shown by Mathews-Roth, carotenoids are providing photoprotective benefits to the skin.⁹⁶ Carotenoids are known to be very effective singlet oxygen quenchers. Singlet oxygen is mainly produced in skin upon UVA exposure, not UVB. This may explain why carotenoids are not the most effective in reducing solar UV-induced erythema, although there are reports demonstrating that oral supplementation with β -carotene provides some level of erythema protection.⁹⁷ Carotenoids are also precursors to vitamin A (retinoids). While it was long believed that carotenoids could only be metabolized into retinoids in erythrocytes and hepatocytes, it is now confirmed that this conversion also happens in the skin.^{98,99} As first shown by Kligman,¹⁰⁰ the actions of retinoids on the skin are numerous. They are used as cosmetic (retinol, retinal, and retinyl esters) and drug (retinoic acid and derivatives) to reduce the appearance of wrinkles, by stimulating collagen, elastin, and hyaluronic acid synthesis, and at the same time inhibiting metalloproteinase activities.^{101–104}

Ascorbic acid is a hydrophilic antioxidant with pleiotropic properties in skin. As reviewed above, ascorbic acid stimulates collagen synthesis. In addition, ascorbic acid promotes skin barrier formation *in vitro*,^{105,106} prevents DNA damage,¹⁰⁷ recycles α -tocopherol radicals,¹⁰⁸ and is used for photoprotection.¹⁰⁹ Ascorbic acid and its derivatives are also used extensively for skin lightening applications. Ascorbic acid is present in high amounts in certain fruits such as Kakadu plums (*Terminalia ferdinandiana*)¹¹⁰ and camu camu (*Myrciaria dubia*), where the total ascorbic acid content is in the 3%–5% range.¹¹¹ Others, like the citrus and kiwi fruits, contain much lower quantities of ascorbic acid (0.05%–0.1%).

Phenolic compounds in botanical extracts like milk thistle (silymarin), pine bark (procyanidins), green tea extract (catechins), oat kernel (avenanthramides), rice bran (ferulic acid), feverfew (flavonoids), *Ginkgo biloba* (flavonoids), licorice (chalcones), or grape (procyanidins, resveratrol) are used for their antioxidant properties, but also for their photoprotective activities.^{64,112–115} For a long time, the mechanism of action of these phenolic compounds was believed to be via their free radical scavenging activity. While this property is important, it appears that perhaps their most physiologically relevant activity is via the activation of Nrf-2 (nuclear factor-erythroid-2-related factor-2), a transcription factor binding to the ARE (antioxidant responsive element), controlling the expression of genes involved in cell detoxication, including catalase expression and the synthesis of glutathione and glutathione peroxidase.^{90,116}

Sulforaphane (an isothiocyanate found in cruciferous vegetables like broccoli or cabbage) is a potent Nrf2 inducer,¹¹⁷ and was found to protect mice against UVB-induced carcinogenesis.¹¹⁸

Sirtuin (SIRT) 1, a deacetylase enzyme involved in cell survival, longevity, and DNA repair, can be activated by resveratrol, mimicking caloric restriction-mediated lifespan extension. Resveratrol is the only phytochemical known to activate SIRT1.⁹¹

Post-translational chemical modifications of proteins appear to play an important role in the etiology of cancers, neurodegenerative diseases, and aging.¹¹⁹ Several phytochemicals, such as isothiocyanates (e.g., sulforaphane in cruciferous vegetables), catechins (e.g., EGCG), and quercetin, have been shown to inhibit histone deacetylases in cancer cells, leading to apoptosis, thus explaining their benefit as chemoprotecting agents.¹²⁰

Pigmentation

Skin darkening and hyperpigmentation are signs of photodamage. Melanogenesis is also part of the skin's adaptive response to protect the skin cells against excessive (and unmanageable) sun damage. Moreover, melanocompetent individuals can develop hyperpigmentation marks with acne lesions or minor wounds. Patients and consumers in various parts of the world and for centuries have looked for solutions to their hyperpigmentation issues.¹²¹ In several parts of Asia, fair skin is associated with a desirable social status.

Melanin production happens in the melanocytes in organelles called melanosomes, with the enzyme tyrosinase converting L-tyrosine into L-dihydroxyphenylalanine (L-DOPA) and L-DOPA into L-dopaquinone, the two limiting steps in the formation of melanin. This makes tyrosinase a chief target for skin lightening agents. Several of the most commonly used tyrosinase inhibitors are derived from nature: arbutin (a glycosylated form of hydroquinone) from *Arctostaphylos uva-ursi* (bearberry),¹²¹ kojic acid from *Aspergillus oryzae*,¹²² and ascorbic acid from many fruits, as reviewed above. Other botanical extracts rich in flavonoids have been shown to inhibit tyrosinase as well: pine bark (*Pinus maritima*), licorice (*Glycyrrhiza glabra*), mulberry leaves (*Morus alba*).¹²³ Resorcinols appear potent tyrosinase inhibitors. Resorcinol is found in argan oil, alkyl and alkenyl resorcinols in rye and wheat grains, and dimethoxytolyl propylresorcinol in *Dianella ensifolia*.¹²⁴ The latter was also found to accelerate the degradation of tyrosinase.¹²⁵

Pathways leading to the activation of the tyrosinase gene expression are also prime targets for skin lightening agents. For instance, α -melanocortin stimulating hormone (α -MSH), stem cell factor (SCF), and endothelin-1 (ET-1) are produced by the keratinocytes or fibroblasts (for SCF) under certain circumstances (e.g., UV exposure) and bind to their respective receptors on the melanocyte membrane, consequently resulting in tyrosinase induction.¹²⁶ While not a tyrosinase activity inhibitor, *Matricaria chamomilla* (chamomile) extract was effective at reducing UVB-induced pigmentation *in vivo*, via the inhibition of ET-1 binding to its receptor.¹²⁷

The transfer of melanosomes to the keratinocytes occurs under the control of the protease-activated receptor-2 (PAR-2), activated by trypsin.¹²⁸ Small peptides found in soybean, soybean trypsin inhibitor (STI) and Bowman–Birk inhibitor (BBI), were found to selectively inhibit PAR-2 activation and reduce UVB-induced pigmentation.¹²⁹

An emerging mode of action to brighten the skin is by using enzymes that degrade superficial melanin. Such enzymatic activities were found with *Sporotrichum pruinosum*,¹³⁰ *Phanerochaete chrysosporium*^{131,132} (identified as a lignin peroxidase), and *Aspergillus fumigatus*.¹³³

Acne

The pathogenesis of acne can be characterized by four main events: bacterial proliferation (*Propionibacterium acnes*), inflammation, excessive sebum production, and irregular keratinization and desquamation in the follicular canal. The exact order of the events leading to acne pathogenesis is still largely unknown. Acne therapies targeted at any one or more of these events have been proven somewhat effective dependent on the severity of the condition.

Among the first line therapies for mild acne, salicylic acid, extracted from wintergreen leaf oil or willow bark, acts as a keratolytic, comedolytic, antibacterial, and anti-inflammatory agent. Salicylic acid is approved as an active in acne OTC products in the United States.¹³⁴ Glycolic acid (10%) has been found effective in improving mild acne.¹³⁵

Although *P. acnes* is a part of the normal skin microbiota, controlling its growth is an important and generally effective therapeutic strategy. Many botanical extracts have demonstrated growth inhibitory activity against *P. acnes*.

Terpenoids-containing oils and extracts appear particularly effective against *P. acnes* and in providing clinical improvements of acne. In clinical studies, tea tree (*Malaleuca alternifolia*) oil, rich in 4-terpenol, has been shown to provide improvements in acne.^{136,137} In a study by Kubo et al.,¹³⁸ totarol, a diterpene extracted from *Podocarpus* tree wood and bark, was the most potent phytochemical at inhibiting *P. acnes*. Nixon and Hobbs presented a case where totarol was effective in improving a patient's acne, although this was not a controlled study.¹³⁹ Other terpene-containing extracts have also been shown to

inhibit *P. acnes* and to improve acne in clinical studies: bakuchiol (*Psoralea corylifolia* seeds),¹⁴⁰ hinokitiol (*Cupressaceae* trees),¹³⁸ and cis-thujopsene (*Copaiba* essential oil).¹⁴¹ Topical treatment with clove basil oil (*Ocimum gratissimum*), rich in eugenol and sesquiterpenes, helped reduced acne lesions faster than a reference containing the benchmark anti-*P. acnes* active benzoyl peroxide.^{142,143}

Azelaic acid is a dicarboxylic acid with demonstrated anti-*P. acnes*, keratolytic, and anti-post-inflammatory hyperpigmentation activities.^{144,145} While it is produced by the commensal fungi *Malassezia furfur* (also associated to dandruff) and is also found in cereals, most of the azelaic acid used in products today is made synthetically.

Acne resolution is dependent on sebum reduction,¹⁴⁶ which makes sebum output an important target in acne control. Excess sebum production is also responsible for greasy hair. The most common biological target in sebum production is the enzyme 5-alpha-reductase, which convert testosterone into dihydrotestosterone, which in turn stimulates the sebaceous gland. Saw palmetto (*Serenoa repens*), *Enantia chlorantha*, cinnamon (*Cinnamomum zeylanicum*) bark extract, *Orthosiphon stamineus*, and green tea have 5-alpha-reductase inhibitory activities. Another approach is with lipase inhibitors to reduce the sebum secretion. This was based on the hypothesis that it is the triglycerides in the sebum that gives the feedback signal. Lipase inhibitors are present in many plants (e.g., *Limnanthes alba* [meadowfoam] oil).¹⁴⁷

While reduction of sebum by a topical agent can be challenging to achieve, some botanical materials rich in silica, starch, or proteins are used to absorb the sebum at the skin surface, mattifying the skin tone: pumpkin seed extract, *Bambusa arundinacea* and orange peel powder.

Antimicrobial Applications

The survival of many plants is often due to their ability to induce phytochemical responses to stress (intense exposure to UV, heat and dryness, and pest and microbiological infestations). These phytochemicals, also known as phytoalexins, comprise a multitude of antimicrobial compounds that have been the basis of traditional medicines for centuries around the world.^{148,149} There are numerous essential oils providing antibacterial, anti-fungal, and anti-viral properties, often through the terpenoids (e.g., linalool, citral) or phenylpropanoids (e.g., eugenol) (see reviews in Carson and Hammer¹⁵⁰ and Hammer and Carson¹⁵¹). These essential oils (e.g., lemon, lavender, tea-tree) are incorporated with soaps or cleansers for body wash or hand wash or sometimes used as-is in traditional medicines to clean skin wounds. In modern cosmetics, they are used to provide natural preservation to products.^{152–154} However, these essential oils should be used carefully, as some of their components can oxidize readily and form haptens, leading to skin sensitization reactions.^{155,156}

As presented above, natural antioxidants such as tocopherols can be used to stabilize or preserve unsaturated fatty acid-containing products against their peroxidation. Transition metal (e.g., iron) chelators like phytic acid (found in wheat, oat, and pumpkin)¹⁵⁷ help stabilize many cosmetic ingredients particularly susceptible to oxidation (e.g., polyphenols, carotenoids).

Coming from the biotechnology, the enzyme system glucose/glucose oxidase/lactoperoxidase (from *Aspergillus*) provides an innovative preservation system, where hydrogen peroxide is produced by the oxidation of glucose by glucose-oxidase, and its level controlled by lactoperoxidase.¹⁵⁸ Consequently, the hydrogen peroxide and reduced pH, due to gluconic acid formed, help to reduce microorganism growth in the product.

Anti-Cellulite or Slimming

Sainio et al. reported 44 different botanical extracts used in 32 cellulite products sold in Helsinki, Finland.¹⁵⁹ Over a decade later, the number of botanical extracts supposedly improving the appearance of cellulite or promising slimming continues to increase, although clinical evidence of their benefits is still sparse.

Cellulite is a condition that affects most women on their thighs and buttocks, where the affinity of the antilipolytic $\alpha 2$ adrenergic receptors is higher.¹⁶⁰ Cellulite is characterized by an enlarged subcutaneous

adipose tissue, defective connective fibers in the adipose tissue, including an increased number of septae perpendicular to the skin surface, inflammation, and increased vascular permeability.^{161–163}

Most botanical extracts used against cellulite tend to disrupt adipogenesis, stimulate lipolysis (controlled by cAMP), or stimulate the microcirculation.

Botanical extracts used in anti-cellulite products can be grouped according to their main active components:

- a. Xanthines (namely caffeine, theobromine, and theophylline), isolated from *Camellia sinensis* (tea), *Paullinia cupana* (guarana), *Coffea arabica*, *Theobroma cacao* and *Ilex paraguariensis* (mate), inhibit phosphodiesterase, which inhibition results in lipolysis. Xanthines stimulate microcirculation via receptor-mediated vasoconstriction.¹⁶⁴
- b. Flavonoids or phenolics (e.g., rutin, quercetin, naringenin, pterocarpan) exert anti-inflammatory activities as well as stimulate microcirculation via increased vascular permeability. Some flavonoids inhibit phosphodiesterase and induce lipolysis.¹⁶⁵ Flavonoids are found in numerous botanical extracts, such as *Ginkgo biloba*, orange peel, lotus leaves, boldo. Pterocarpan from *Bobgunnia madagascariensis* wood have been shown to inhibit adipogenesis.¹⁶⁶
- c. Terpenoids: Saponin-type terpenes, like ruscogenin (*Ruscus aculeatus* or butcher's broom), escin (horse chestnut), glycyrrhizin (licorice), asiaticosides (*Centella asiatica*), ginsenosides (ginseng), and ginkgolides (ginkgo), reduce vascular permeability and induce vasoconstriction, which increases local microcirculation. The diterpene forskolin, isolated from *Coleus forskolii*, is a strong activator of adenylyl cyclase, which produces cAMP, subsequently inducing lipolysis.¹⁶⁷

Disaccharides from red algae (*Rhodophyceae*) were found to trap polyamines and consequently inhibit the differentiation of pre-adipocyte into adipocytes and lipogenesis, and stimulate lipolysis.¹⁶⁸

Despite the high diversity of treatment options, effective cellulite treatment remains an unmet need from a consumer perspective. In a recent meta-analysis of clinical trials for cellulite products, Turati et al. concluded that only a moderate thigh circumference reduction can be demonstrated,¹⁶⁹ based on studies including combination treatments.

Conclusion

Botanical extracts are being used in many applications, both in cosmetics and drugs (OTC or traditional). The main difference between cosmetics and drugs is the intention of the manufacturer as reflected by the product claim (i.e., cure or disease prevention rather than improvement of the overall condition of the skin or hair by maintaining or improving the natural processes).

Most cosmetic products today address both the rational and the emotional aspects that characterize their need in society, though they are often still considered as a “dream in a bottle” (Charles Revson).

Botanicals are playing an increasingly important role in the activity and safety of cosmetics. Decades after large botanical prospection efforts failed to identify new blockbuster drugs, the pharmaceutical industry is turning again to botanicals, using the advancements in plant genomics, to discover the drugs of the future.

REFERENCES

1. European Union European Commission. Council Directive 93/35/EEC of 14 June 1993 amending for the sixth time Directive 76/768/EEC on the approximation of the laws of the Member States relating to cosmetic products. *Off J Eur Comm* 1993;151:32–7.
2. European Union European Commission. Directive 2003/15/EC of the European Parliament and of the Council of 27 February 2003 amending Council Directive 76/768/EEC on the approximation of the laws of the Member States relating to cosmetic products. *Off J Eur Union* 2003;66:26–35.

3. European Union European Commission. Regulation (EC) no 1223/2009 of the European Parliament and of the Council of 30 November 2009 on cosmetic products (recast). *Official J Eur Union* 2009;L342:59–209.
4. Khaïat A. Cosmeceuticals or cosmetics: Industry responsibility. *Cosmet Toiletries*. 1993;108:23.
5. Forbes RJ. *Studies in Ancient Technology*. Biggleswade: E.J.Brill; 1957.
6. Gertsch J. Botanical drugs, synergy, and network pharmacology: Forth and back to intelligent mixtures. *Planta Med* 2011;77:1086–98.
7. Santana-Rios G, Orner GA, Amantana A et al. Potent antimutagenic activity of white tea in comparison with green tea in the Salmonella assay. *Mutat Res* 2001;495:61–74.
8. US Department of Health and Human Services, Food and Drug Administration, Center for Drug Evaluation and Research (CDER). Guidance for Industry. Botanical Drug Products 2004 [10/7/2013]. Available from: <http://www.fda.gov/downloads/Drugs/GuidanceComplianceRegulatoryInformation/Guidances/UCM070491.pdf>.
9. Stockfleth E, Meyer T. The use of sinecatechins (polyphenon E) ointment for treatment of external genital warts. *Exp Opin Biol Ther* 2012;12:783–93.
10. Tatti S, Swinehart JM, Thielert C et al. Sinecatechins, a defined green tea extract, in the treatment of external anogenital warts: A randomized controlled trial. *Obstet Gynecol* 2008;111:1371–9.
11. Tradtrantip L, Namkung W, Verkman AS. Crofelemer, an antisecretory antidiarrheal proanthocyanidin oligomer extracted from *Croton lechleri*, targets two distinct intestinal chloride channels. *Mol Pharmacol* 2010;77:69–78.
12. Chordia P, MacArthur RD. Crofelemer, a novel agent for treatment of non-infectious diarrhea in HIV-infected persons. *Exp Rev Gastroenterol Hepatol* 2013;7:591–600.
13. Saklani A, Kutty SK. Plant-derived compounds in clinical trials. *Drug Discov Today* 2008;13:161–71.
14. Matkar NM. Natural and synthetic hair dyes: A solution for graying hair. *Cosmet Toiletries* 2000;115:77–86.
15. Bocchietto E, Allan N. Case for biotechnology. *Soap Perf Cosmet* 1996;69:43–7.
16. Erickson B, Winters P. Perspective on opportunities in industrial biotechnology in renewable chemicals. *Biotechnol J* 2012;7:176–85.
17. Meng X, Yang J, Xu X et al. Biodiesel production from oleaginous microorganisms. *Renewable Energy* 2009;34:1–5.
18. Kunle OF, Egharevba HO, Ahmadu PO. Standardization of herbal medicines—A review. *Int J Biodiv Conserv* 2012;4:101–12.
19. Sheeba M, Rajesh M, Vallabhan CPG et al. Fibre optic sensor for the detection of adulterant traces in coconut oil. *Meas Sci Technol* 2005;16:2247.
20. Baker DA. DNA barcode identification of black cohosh herbal dietary supplements. *J AOAC Int* 2012;95:1023–34.
21. Jiang B, Ma C, Motley T et al. Phytochemical fingerprinting to thwart black cohosh adulteration: A 15 *Actaea* species analysis. *Phytochem Anal* 2011;22:339–51.
22. ASTM. D6866—12. *Standard Test Methods for Determining the Biobased Content of Solid, Liquid, and Gaseous Samples Using Radiocarbon Analysis* West Conshohocken, PA: ASTM International; 2012.
23. Robinson DF. *Confronting Biopiracy: Challenges, Cases and International Debates*. London, Washington, DC: Earthscan; 2010. xvi, 190p.
24. Magalhães WV, Baby AR, Velasco MVR et al. Patenting in the cosmetic sector: Study of the use of herbal extracts. *Braz J Pharm Sci*. 2011;47:693–700.
25. ten Kate K. Science and the convention on biological diversity. *Science* 2002;295:2371–2.
26. Wang L, Weller CL. Recent advances in extraction of nutraceuticals from plants. *Trends Food Sci Technol* 2006;17:300–12.
27. Kaufmann B, Christen P. Recent extraction techniques for natural products: Microwave-assisted extraction and pressurised solvent extraction. *Phytochem Anal* 2002;13:105–13.
28. Le HV, Le VVM. Comparison of enzyme-assisted and ultrasound-assisted extraction of vitamin C and phenolic compounds from acerola (*Malpighia emarginata* DC.) fruit. *Int J Food Sci Technol* 2012;47:1206–14.
29. Rozzi NL, Singh RK. Supercritical fluids and the food industry. *Comp Rev Food Sci Food Safety* 2002;1:33–44.

30. Yang GY, Liao J, Kim K et al. Inhibition of growth and induction of apoptosis in human cancer cell lines by tea polyphenols. *Carcinogenesis* 1998;19:611–6.
31. Thum O, Oxenbell KM. Biocatalysis-A sustainable method for the production of emollient esters. *SOFW J.* 2008;134:44.
32. Lalonde J. Enzyme catalysis: Cleaner, safer, energy efficient. *Chem Eng* 1997;104:108–12.
33. Li BB, Smith B, Hossain MM. Extraction of phenolics from citrus peels: II. Enzyme-assisted extraction method. *Sep Purif Technol* 2006;48:189–96.
34. Kogan G, Šoltés L, Stern R et al. Hyaluronic acid: A natural biopolymer with a broad range of biomedical and industrial applications. *Biotechnol Lett* 2007;29:17–25.
35. Biermann U, Friedt W, Lang S et al. New syntheses with oils and fats as renewable raw materials for the chemical industry. *Angew Chem Int Ed* 2000;39:2206–24.
36. Vertuani S, Beghelli E, Scalambra E et al. Activity and stability studies of verbascoside, a novel antioxidant, in dermo-cosmetic and pharmaceutical topical formulations. *Molecules* 2011;16:7068–80.
37. Evans DE, Coleman JOD, Kearns A. *Plant Cell Culture*. London, New York: BIOS Scientific Publishers; 2003, xiv, 194pp.
38. Atiyeh BS, Ibrahim AE, Dibo SA. Cosmetic mesotherapy: Between scientific evidence, science fiction, and lucrative business. *Aesthetic Plast Surg* 2008;32:842–9.
39. Kilfoyle BE, Kaushik D, Terebetski JL et al. The use of quercetin and curcumin in skin care consumer products. In: Dayan N, Kromidas L, eds. *Formulating, Packaging, and Marketing of Natural Cosmetic Products*. Hoboken, NJ: John Wiley & Sons, Inc.; 2011, pp.259–86.
40. Tsunoda T, Takabayashi K. Stability of all-trans-retinol in cream. *J Soc Cosmet Chem* 1995;46:191–8.
41. Saraf S. Applications of novel drug delivery system for herbal formulations. *Fitoterapia* 2010;81:680–9.
42. Munin A, Edwards-Lévy F. Encapsulation of natural polyphenolic compounds: A review. *Pharmaceutics* 2011;3:793–829.
43. Guth J, Cappabianca C. Oleosomes: Natural, self-emulsifying systems. *Cosmet Toilet* 2006;121:49–57.
44. Wang KH, Lin RD, Hsu FL et al. Cosmetic applications of selected traditional Chinese herbal medicines. *J Ethnopharmacol* 2006;106:353–9.
45. Tan HY, Zhang AL, Chen D et al. Chinese herbal medicine for atopic dermatitis: A systematic review. *J Am Acad Dermatol* 2013:295–304.
46. Menon GK, Cleary GW, Lane ME. The structure and function of the stratum corneum. *Int J Pharm* 2012;435:3–9.
47. Calder PC. Omega-3 fatty acids and inflammatory processes. *Nutrients* 2010;2:355–74.
48. McCusker MM, Grant-Kels JM. Healing fats of the skin: The structural and immunologic roles of the ω -6 and ω -3 fatty acids. *Clin Dermatol* 2010;28:440–51.
49. Ziboh VA, Miller CC, Cho Y. Metabolism of polyunsaturated fatty acids by skin epidermal enzymes: Generation of antiinflammatory and antiproliferative metabolites. *Am J Clin Nutr* 2000;71:361s–6s.
50. Li Y, Horsman M, Wu N et al. Biofuels from microalgae. *Biotechnol Progr* 2008;24:815–20.
51. Calder P. Long-chain polyunsaturated fatty acids and inflammation. *Scand J Food Nutr* 2006;50:54–61.
52. Darmstadt GL, Mao-Qiang M, Chi E et al. Impact of topical oils on the skin barrier: Possible implications for neonatal health in developing countries. *Acta Paediatr* 2002;91:546–54.
53. Ando H, Matsui MS, Ichihashi M. Quasi-drugs developed in Japan for the prevention or treatment of hyperpigmentary disorders. *Int J Mol Sci* 2010;11:2566–75.
54. Latreille J, Kesse-Guyot E, Malvy D et al. Association between dietary intake of n-3 polyunsaturated fatty acids and severity of skin photoaging in a middle-aged Caucasian population. *J Dermatol Sci.* 2013:233–9.
55. Athar M, Nasir SM. Taxonomic perspective of plant species yielding vegetable oils used in cosmetics and skin care products. *Afr J Biotechnol* 2005;4:36–44.
56. Biello D. The false promise of biofuels. *Sci Am* 2011;305:58–65.
57. Khallouki F, Younos C, Soulimani R et al. Consumption of argan oil (Morocco) with its unique profile of fatty acids, tocopherols, squalene, sterols and phenolic compounds should confer valuable cancer chemopreventive effects. *Eur J Cancer Prev* 2003;12:67–75.
58. Reiter E, Jiang Q, Christen S. Anti-inflammatory properties of alpha- and gamma-tocopherol. *Mol Aspects Med* 2007;28:668–91.
59. Puglia C, Bonina F. *In vivo* spectrophotometric evaluation of skin barrier recovery after topical application of soybean phytosterols. *J Cosmet Sci* 2008;59:217.

60. Ishikawa J, Yoshida H, Ito S et al. Dry skin in the winter is related to the ceramide profile in the stratum corneum and can be improved by treatment with a Eucalyptus extract. *J Cosmet Dermatol* 2013;12:3–11.
61. Kim H, Oh I, Park KH et al. Stimulatory effect of dietary red ginseng on epidermal hydration and ceramide levels in ultraviolet-irradiated hairless mice. *J Med Food* 2009;12:746–54.
62. Dal'Belo SE, Rigo Gaspar L, Campos BGM et al. Moisturizing effect of cosmetic formulations containing Aloe vera extract in different concentrations assessed by skin bioengineering techniques. *Skin Res Technol* 2006;12:241–6.
63. Joseph J, Kanchalochana SN, Rajalakshmi G et al. Tamarind seed polysaccharide: A promising natural excipient for pharmaceuticals. *Int J Green Pharm* 2012;6:270.
64. Mahmood K, Saliou C, Wallo W. Nutrient-rich botanicals in skin health: Focus on *Avena sativa*. In: Watson RR, Zibadi S, eds. *Bioactive Dietary Factors and Plant Extracts in Dermatology*. Berlin: Springer; 2013, pp.153–68.
65. Kamatou GPP, Viljoen AM. A review of the application and pharmacological properties of α -bisabolol and α -bisabolol-rich oils. *J Am Oil Chem Soc* 2010;87:1–7.
66. Gilchrist BA. Photoaging. *J Invest Dermatol* 2013;133:E2–E6.
67. Murad S, Grove D, Lindberg KA et al. Regulation of collagen synthesis by ascorbic acid. *Proc Natl Acad Sci USA* 1981;78:2879–82.
68. Geesin JC, Darr D, Kaufman R et al. Ascorbic acid specifically increases type I and type III procollagen messenger RNA levels in human skin fibroblast. *J Invest Dermatol* 1988;90:420–4.
69. Tenni R, Zanaboni G, De Agostini MP et al. Effect of the triterpenoid fraction of *Centella asiatica* on macromolecules of the connective matrix in human skin fibroblast cultures. *Ital J Biochem* 1988;37:69–77.
70. Hashim P, Sidek H, Helan M et al. Triterpene composition and bioactivities of *Centella asiatica*. *Molecules* 2011;16:1310–22.
71. Morishita K, Yamasaki M, Takao T. Increasing effect of an oral intake of L-hydroxyproline on the soluble collagen content of skin and collagen fragments in rat serum. *Biosci Biotechnol Biochem* 2012;76:1242–4.
72. Han B, Jaurequi J, Tang BW et al. Proanthocyanidin: A natural crosslinking reagent for stabilizing collagen matrices. *J Biomed Mater Res A* 2003;65:118–24.
73. Herrmann M, Grether-Beck S, Meyer I et al. Blackberry leaf extract: A multifunctional anti-aging active. *Int J Cosmetic Sci* 2007;29:411.
74. Thring TSA, Hili P, Naughton DP. Anti-collagenase, anti-elastase and anti-oxidant activities of extracts from 21 plants. *BMC Complement* 2009;9:27.
75. Moon HJ, Lee SR, Shim SN et al. Fucoidan inhibits UVB-induced MMP-1 expression in human skin fibroblasts. *Biol Pharm Bull* 2008;31:284–9.
76. Lee J, Lee SH, Min KR et al. Inhibitory effects of hydrolyzable tannins on Ca²⁺-activated hyaluronidase. *Planta Med* 1993;59:381–2.
77. Green BA, Yu RJ, Van Scott EJ. Clinical and cosmeceutical uses of hydroxyacids. *Clin Dermatol* 2009;27:495–501.
78. Bernstein EF, Lee J, Brown DB et al. Glycolic acid treatment increases type I collagen mRNA and hyaluronic acid content of human skin. *Dermatol Surg* 2001;27:429–33.
79. Smith WP, Bishop M, Gillis G et al. Topical proteolytic enzymes affect epidermal and dermal properties. *Int J Cosmetic Sci* 2007;29:15–21.
80. Hyde KD, Bahkali AH, Moslem MA. Fungi—An unusual source for cosmetics. *Fungal Div* 2010;43:1–9.
81. Sim YC, Lee SG, Lee DC et al. Stabilization of papain and lysozyme for application to cosmetic products. *Biotechnol Lett* 2000;22:137–40.
82. Maurer HR. Bromelain: Biochemistry, pharmacology and medical use. *Cell Mol Life Sci* 2001;58:1234–45.
83. Reddy VB, Lerner EA. Plant cysteine proteases that evoke itch activate protease-activated receptors. *Br J Dermatol* 2010;163:532–5.
84. Lee BC, Bae JT, Pyo HB et al. Biological activities of the polysaccharides produced from submerged culture of the edible Basidiomycete *Grifola frondosa*. *Enzyme Microb* 2003;32:574–81.
85. Estrada A, Yun CH, Van Kessel A et al. Immunomodulatory activities of oat beta-glucan *in vitro* and *in vivo*. *Microbiol Immunol* 1997;41:991–8.
86. Pillai R, Redmond M, Röding J. Anti-wrinkle therapy: Significant new findings in the non-invasive cosmetic treatment of skin wrinkles with beta-glucan. *Int J Cosmetic Sci* 2005;27:292.

87. Bickers DR, Athar M. Oxidative stress in the pathogenesis of skin disease. *J Invest Dermatol* 2006;126:2565–75.
88. Shapiro SS, Saliou C. Role of vitamins in skin care. *Nutrition* 2001;17:839–44.
89. Oresajo C, Stephens T, Hino PD et al. Protective effects of a topical antioxidant mixture containing vitamin C, ferulic acid, and phloretin against ultraviolet-induced photodamage in human skin. *J Cosmet Dermatol* 2008;7:290–7.
90. Surh YJ, Kundu JK, Na HK. Nrf2 as a master redox switch in turning on the cellular signaling involved in the induction of cytoprotective genes by some chemopreventive phytochemicals. *Planta Med* 2008;74:1526–39.
91. Villalba JM, Alcain FJ. Sirtuin activators and inhibitors. *Biofactors* 2012;38:349–59.
92. Urano S, Inomori Y, Sugawara T et al. Vitamin E: Inhibition of retinol-induced hemolysis and membrane-stabilizing behavior. *J Biol Chem* 1992;267:18365–70.
93. Wagner KH, Isnardy B, Elmadfa I. γ - and δ -tocopherols are more effective than α -tocopherol on the autoxidation of a 10% rapeseed oil triacylglycerol-in-water emulsion with and without a radical initiator. *Eur J Lipid Sci Technol* 2004;106:44–51.
94. McVean M, Liebler DC. Prevention of DNA photodamage by vitamin E compounds and sunscreens: Roles of ultraviolet absorbance and cellular uptake. *Mol Carcinog* 1999;24:169–76.
95. Gunstone FD. ed. *Vegetable Oils in Food Technology: Composition, Properties and Uses*, 2nd edn. Oxford: Wiley-Blackwell; 2011.
96. Mathews-Roth MM, Pathak MA, Parrish J et al. A clinical trial of the effects of oral beta-carotene on the responses of human skin to solar radiation. *J Invest Dermatol* 1972;59:349–53.
97. Stahl W, Heinrich U, Jungmann H et al. Carotenoids and carotenoids plus vitamin E protect against ultraviolet light-induced erythema in humans. *Am J Clin Nutr* 2000;71:795–8.
98. D'Ambrosio DN, Clugston RD, Blaner WS. Vitamin A metabolism: An update. *Nutrients* 2011;3:63–103.
99. Antille C, Tran C, Sorg O et al. Topical beta-carotene is converted to retinyl esters in human skin *ex vivo* and mouse skin *in vivo*. *Exp Dermatol* 2004;13:558–61.
100. Kligman LH, Kligman AM. The effect on rhino mouse skin of agents which influence keratinization and exfoliation. *J Invest Dermatol* 1979;73:354–8.
101. Fisher GJ, Datta SC, Talwar HS et al. Molecular basis of sun-induced premature skin ageing and retinoid antagonism. *Nature* 1996;379:335–9.
102. Fisher GJ, Varani J, Voorhees JJ. Looking older: Fibroblast collapse and therapeutic implications. *Arch Dermatol* 2008;144:666–72.
103. Rossetti D, Kielmanowicz MG, Vigodman S et al. A novel anti-ageing mechanism for retinol: Induction of dermal elastin synthesis and elastin fibre formation. *Int J Cosmetic Sci* 2011;33:62–9.
104. King IA, Tabiowo A. The effect of all-trans-retinoic acid on the synthesis of epidermal cell-surface-associated carbohydrates. *Biochem J* 1981;194:341–51.
105. Ponc M, Weerheim A, Kempenaar J et al. The formation of competent barrier lipids in reconstructed human epidermis requires the presence of vitamin C. *J Invest Dermatol* 1997;109:348–55.
106. Uchida Y, Behne M, Quiec D et al. Vitamin C stimulates sphingolipid production and markers of barrier formation in submerged human keratinocyte cultures. *J Invest Dermatol* 2001;117:1307–13.
107. Sugimoto M, Okugawa Y, Miwa N. Preventive effects of phosphorylated ascorbate on ultraviolet-B induced apoptotic cell death and DNA strand cleavage through enrichment of intracellular vitamin C in skin epidermal keratinocytes. *Free Radic Res* 2006;40:213–21.
108. Kagan V, Witt E, Goldman R et al. Ultraviolet light-induced generation of vitamin E radicals and their recycling. A possible photosensitizing effect of vitamin E in skin. *Free Radic Res Commun* 1992;16:51–64.
109. Stamford NP. Stability, transdermal penetration, and cutaneous effects of ascorbic acid and its derivatives. *J Cosmet Dermatol* 2012;11:310–7.
110. Mohanty S, Cock IE. The chemotherapeutic potential of *Terminalia ferdinandiana*: Phytochemistry and bioactivity. *Pharmacogn Rev* 2012;6:29–36.
111. McAnalley BH, Vennum E, Ramberg J et al. Antioxidants: Consolidated review of potential benefits. *GlycoSci Nutr* 2004;5:1–21.
112. Packer L, Saliou C, Droy-Lefaix MT et al. *Ginkgo biloba* extract (EGb761): Biological actions, antioxidant activity, and regulation of nitric oxide synthase. In: Packer L, Rice-Evans C, eds *Flavonoids in Health and Disease. Antioxidants in Health and Disease*. New York: Marcel Dekker, Inc.; 1998. p. 303–41.

113. Saliou C, Kitazawa M, McLaughlin L et al. Antioxidants modulate acute solar ultraviolet radiation-induced NF-kappa-B activation in a human keratinocyte cell line. *Free Radic Biol Med.* 1999;26:174–83.
114. Saliou C, Rimbach G, Moini H et al. Solar ultraviolet-induced erythema in human skin and nuclear factor-kappa-B-dependent gene expression in keratinocytes are modulated by a French maritime pine bark extract. *Free Radic Biol Med.* 2001;30:154–60.
115. Hsu S. Green tea and the skin. *J Am Acad Dermatol.* 2005;52:1049–59.
116. Rahman I, Biswas SK, Kirkham PA. Regulation of inflammation and redox signaling by dietary polyphenols. *Biochem Pharmacol.* 2006;72:1439–52.
117. Gao X, Dinkova-Kostova AT, Talalay P. Powerful and prolonged protection of human retinal pigment epithelial cells, keratinocytes, and mouse leukemia cells against oxidative damage: The indirect antioxidant effects of sulforaphane. *Proc Natl Acad Sci USA* 2001;98:15221–6.
118. Saw CL, Huang MT, Liu Y et al. Impact of Nrf2 on UVB-induced skin inflammation/photoprotection and photoprotective effect of sulforaphane. *Mol Carcinog* 2011;50:479–86.
119. Lopez-Otin C, Blasco MA, Partridge L et al. The hallmarks of aging. *Cell* 2013;153:1194–217.
120. Rajendran P, Williams DE, Ho E et al. Metabolism as a key to histone deacetylase inhibition. *Crit Rev Biochem Mol Biol* 2011;46:181–99.
121. Matsuda H, Murata K, Itoh K et al. Melanin hyperpigmentation inhibitors from natural resources. In: *Advances in Malignant Melanoma—Clinical and Research Perspectives*. InTech, 2011. Available from: <http://www.intechopen.com/books/advances-in-malignant-melanoma-clinical-and-research-perspectives/melanin-hyperpigmentation-inhibitors-from-natural-resources>.
122. Barham HN, Smits BL. Kojic acid: A review. *Trans Kans Acad Sci* 1934;37:91–113.
123. Zhu W, Gao J. The use of botanical extracts as topical skin-lightening agents for the improvement of skin pigmentation disorders. *J Invest Dermatol Symp Proc* 2008;13:20–4.
124. Nesterov A, Zhao J, Minter D et al. 1-(2,4-dihydroxyphenyl)-3-(2,4-dimethoxy-3-methylphenyl)propane, a novel tyrosinase inhibitor with strong depigmenting effects. *Chem Pharm Bull (Tokyo)* 2008;56:1292–6.
125. Niki Y, Yoshida M, Ando H et al. 1-(2,4-Dihydroxyphenyl)-3-(2,4-dimethoxy-3-methylphenyl)propane inhibits melanin synthesis by dual mechanisms. *J Dermatol Sci* 2011;63:115–21.
126. Imokawa G. Autocrine and paracrine regulation of melanocytes in human skin and in pigmentary disorders. *Pigment Cell Res.* 2004;17:96–110.
127. Imokawa G, Kobayashi T, Miyagishi M et al. The role of endothelin-1 in epidermal hyperpigmentation and signaling mechanisms of mitogenesis and melanogenesis. *Pigment Cell Res* 1997;10:218–28.
128. Seiberg M, Paine C, Sharlow E et al. The protease-activated receptor 2 regulates pigmentation via keratinocyte-melanocyte interactions. *Exp Cell Res* 2000;254:25–32.
129. Paine C, Sharlow E, Liebel F et al. An alternative approach to depigmentation by soybean extracts via inhibition of the PAR-2 pathway. *J Invest Dermatol* 2001;116:587–95.
130. Mohorčić M, Friedrich J, Renimel I et al. Production of melanin bleaching enzyme of fungal origin and its application in cosmetics. *Biotechnol Bioprocess Eng.* 2007;12:200–6.
131. Woo SH, Cho JS, Lee BS et al. Decolorization of melanin by lignin peroxidase from *Phanerochaete chrysosporium*. *Biotechnol Bioprocess Eng* 2004;9:256–60.
132. Mauricio T, Karmon Y, Khaiat A. A randomized and placebo-controlled study to compare the skin-lightening efficacy and safety of lignin peroxidase cream vs. 2% hydroquinone cream. *J Cosmet Dermatol* 2011;10:253–9.
133. Mammone T, Marenus K, Muizzuddin N et al. Evidence and utility of melanin degrading enzymes. *J Cosmet Sci* 2003;55:116–7.
134. Department of health and human services. Topical acne drug products for over-the-counter human use; Final monograph. *Fed Reg* 1991;56:41008–20.
135. Abels C, Kaszuba A, Michalak I et al. A 10% glycolic acid containing oil-in-water emulsion improves mild acne: A randomized double-blind placebo-controlled trial. *J Cosmet Dermatol* 2011;10:202–9.
136. Bassett IB, Pannowitz DL, Barnetson RS. A comparative study of tea-tree oil versus benzoylperoxide in the treatment of acne. *Med J Aust* 1990;153:455–8.
137. Enshaieh S, Jooya A, Siadat AH et al. The efficacy of 5% topical tea tree oil gel in mild to moderate acne vulgaris: A randomized, double-blind placebo-controlled study. *Indian J Dermatol Venereol Leprol* 2007;73:22–5.
138. Kubo I, Muroi H, Kubo A. Naturally occurring antiacne agents. *J Nat Prod* 1994;57:9–17.

139. Nixon D, Hobbs D. The use of Totarol to treat acne in an adolescent: A case study. *NZ Fam Phys* 2006;33:253–5.
140. Shalita AR, Geen SC, Lee WL et al. A clinical study evaluating the dermatologic benefits of topical bakuchiol (UP256) cream on facial acne. *J Am Acad Dermatol* 2011;64:AB19.
141. da Silva AG, Puziol PdF, Leitao RN et al. Application of the essential oil from Copaiba (*Copaifera langsdorffii* Desf.) for acne vulgaris: A double-blind, placebo controlled clinical trial. *Alt Med Rev* 2012;17:69–75.
142. Orafidiya LO, Agbani EO, Oyedele AO et al. Preliminary clinical tests on topical preparations of *Ocimum gratissimum* Linn leaf essential oil for the treatment of acne vulgaris. *Clin Drug Invest* 2002;22:313–9.
143. Prabhu KS, Lobo R, Shirwaikar AA et al. *Ocimum gratissimum*: A review of its chemical, pharmacological and ethnomedicinal properties. *The Open Compl Med J* 2009;1:1–15.
144. Gamble R, Dunn J, Dawson A et al. Topical antimicrobial treatment of acne vulgaris. *Am J Clin Dermatol* 2012;13:141–52.
145. Kircik LH. Efficacy and safety of azelaic acid (AzA) gel 15% in the treatment of post-inflammatory hyperpigmentation and acne: A 16-week, baseline-controlled study. *J Drugs Dermatol* 2011;10:586–90.
146. Janiczek-Dolphin N, Cook J, Thiboutot D et al. Can sebum reduction predict acne outcome? *Br J Dermatol* 2010;163:683–8.
147. Khaiat A. *Process for the treatment of skins having dry areas and greasy areas*. U.S. patent U.S.5741496, 1998.
148. Cowan MM. Plant products as antimicrobial agents. *Clin Microbiol Rev* 1999;12:564–82.
149. Suffredini IB, Sader HS, Gonçalves AG et al. Screening of antibacterial extracts from plants native to the Brazilian Amazon Rain Forest and Atlantic Forest. *Br J Med Biol Res* 2004;37:379–84.
150. Carson CF, Hammer KA. Chemistry and bioactivity of essential oils. In: Thormar H, ed. *Lipids and Essential Oils as Antimicrobial Agents*. New York: John Wiley & Sons; 2011, pp.203–38.
151. Hammer KA, Carson CF. Antibacterial and antifungal activities of essential oils. In: Thormar H, ed. *Lipids and Essential Oils as Antimicrobial Agents*. New York: John Wiley & Sons; 2011, pp.255–306.
152. Burt S. Essential oils: Their antibacterial properties and potential applications in foods—A review. *Int J Food Microb* 2004;94:223–53.
153. Kunicka-Styczyńska A, Sikora M, Kalembe D. Antimicrobial activity of lavender, tea tree and lemon oils in cosmetic preservative systems. *J Appl Microbiol* 2009;107:1903–11.
154. Varvaresou A, Papageorgiou S, Tsirivas E et al. Self-preserving cosmetics. *Int J Cosmetic Sci* 2009;31:163–75.
155. Schnuch A, Uter W, Geier J et al. Sensitization to 26 fragrances to be labelled according to current European regulation. Results of the IVDK and review of the literature. *Contact Dermatitis* 2007;57:1–10.
156. Karlberg AT, Bergström MA, Börje A et al. Allergic acontact dermatitis—Formation, structural requirements, and reactivity of skin sensitizers. *Chem Res Toxicol* 2007;21:53–69.
157. Duke JA. *Handbook of Phytochemical Constituents of GRAS Herbs and Other Economic Plants*. Boca Raton, FL: CRC Press; 2001, 680pp.
158. Wong CM, Wong KH, Chen XD. Glucose oxidase: Natural occurrence, function, properties and industrial applications. *Appl Microbiol Biotechnol* 2008;78:927–38.
159. Sainio EL, Rantanen T, Kanerva L. Ingredients and safety of cellulite creams. *Eur J Dermatol* 2000;10:596–603.
160. Wahrenberg H, Lönnqvist F, Arner P. Mechanisms underlying regional differences in lipolysis in human adipose tissue. *J Clin Invest* 1989;84:458.
161. Avram MM. Cellulite: A review of its physiology and treatment. *J Cosmet Laser Ther* 2004;6:181–5.
162. Quatresooz P, Xhaufaire-Uhoda E, Pierard-Franchimont C et al. Cellulite histopathology and related mechanobiology. *Int J Cosmetic Sci* 2006;28:207–10.
163. Terranova F, Berardesca E, Maibach H. Cellulite: Nature and aetiopathogenesis. *Int J Cosmetic Sci* 2006;28:157–67.
164. Lupi O, Semenovitch IJ, Treu C et al. Evaluation of the effects of caffeine in the microcirculation and edema on thighs and buttocks using the orthogonal polarization spectral imaging and clinical parameters. *J Cosmet Dermatol* 2007;6:102–7.
165. Kuppusamy UR, Das NP. Effects of flavonoids on cyclic AMP phosphodiesterase and lipid mobilization in rat adipocytes. *Biochem Pharmacol* 1992;44:1307–15.

166. Meyer I, Koch O, Hillebrand N et al. *Use of pterocarpanes as active anti-cellulite ingredients*. U.S. patent U.S.20110034486, 2010.
167. Roure R, Oddos T, Rossi A et al. Evaluation of the efficacy of a topical cosmetic slimming product combining tetrahydroxypropyl ethylenediamine, caffeine, carnitine, forskolin and retinol, *in vitro*, *ex vivo* and *in vivo* studies. *Int J Cosmetic Sci* 2011;33:519–26.
168. Vogelgesang B, Bonnet I, Godard N et al. *In vitro* and *in vivo* efficacy of sulfo-carrabiose, a sugar-based cosmetic ingredient with anti-cellulite properties. *Int J Cosmetic Sci* 2011;33:120–5.
169. Turati F, Pelucchi C, Marzatico F et al. Efficacy of cosmetic products in cellulite reduction: Systematic review and meta-analysis. *J Eur Acad Dermatol Venereol* 2014;28:1–15.

Biomarine Actives

Gina Athwal

Marine-based therapies have been globally valued for centuries for nutraceutical benefits and to soothe, beautify, and rejuvenate human skin. Yet, until fairly recently, their bioactive compounds, nutraceutical properties, and commercial cosmeceutical and medical potential remained relatively undiscovered. The potential bioactive chemical treasure-trove in our oceans has yet to be fully explored and researched. Many biomarine active chemicals have probably developed by random mutations due to adapting to harsh underwater environmental conditions.^{1,2}

Attributes of cosmeceutical applications of biomarine actives range from increasing antioxidant activity,³ boosting immunity,⁴ and improving cell matrix configuration⁵ to increasing anti-inflammatory activity.^{3,4} These are activities that synergistically work toward boosting skin metabolism and aiding with fibroblast and elastin production, ultimately resulting in wrinkle reduction and skin smoothing.

Biomarine Extracts

Therapeutic marine extracts enable enhanced skin smoothing and hydration, reduced inflammatory response, rapid wound healing, immunity boosting and growth factor stimulation, and antioxidant protection, among a plethora of other genetically-validated dermatological biomarker enhancements.

Proteoglycans are high molecular-weight polymers of sulfated sugars bound to proteins, and consist of a core protein (collagen) bound with multiple sulfated carbohydrates (glycosaminoglycans).⁶ They are a major component of the extracellular matrix. Here they form large complexes, both with other proteoglycans, hyaluronan, and with fibrous matrix proteins (such as collagen). They are also involved in regulating the movement of molecules through the matrix.⁶ Evidence also shows they can affect the activity and stability of proteins and cell-signaling molecules within the matrix. Cell recognition and adhesion involving many kinds of cell surface molecules operate via homotypic and/or heterotypic protein–protein and protein–carbohydrate binding.⁷ Investigations in marine sponges have provided direct evidence for a novel molecular mechanism of multivalent glycan–glycan binding related to cellular interactions. Biochemical characterization of purified proteoglycans revealed the presence of specific acidic glycans, different from classical glycosaminoglycans.⁷ Such acidic glycans of high molecular weight, containing fucose, glucuronic or galacturonic acids, and pyruvate and sulfate groups may represent a new class of primordial proteoglycans, called glyconectins.⁷

Hundreds of sponges have been screened for bioactive chemicals, with many found to contain antimicrobial substances. For example, extracts from clams, oysters, and abalone, including Paolin I and Paolin II, have antimicrobial activity against multiple bacteria including *Staphylococci* and *Streptococci*.⁸ Paolin II also inhibits herpes viruses and adenoviruses.⁹

Other biomarine actives known as pseudopterosins (diterpene glycosides) isolated from sea whip, *Pseudopterogorgia elisabethae*, have demonstrated anti-inflammatory and analgesic activity, with a mechanism of action different from common non-steroidal anti-inflammatory drugs, (NSAIDS).^{10,11} The discovery of their anti-inflammatory properties has led to studies examining their usefulness in various dermatological inflammatory conditions ranging from psoriasis, contact dermatitis, photodamage, and dermatoheliosis, as well as HIV and cancer.¹² The pseudopterosins hold promise as novel anti-inflammatory compounds.¹² Pseudopterosins may prove a viable alternative to conventional therapies in

preventing and treating inflammatory disorders involving the skin and other organ systems. They have also been cited as being a novel treatment for acne vulgaris.¹²

Ceramides are the major lipid constituent of the stratum corneum. These lamellar sheets contribute to the barrier property of the stratum corneum and the epidermis.⁴ Structurally heterogeneous, ceramides are a complex group of sphingolipids. They contain derivatives of sphingosine bases in amide linkages with a variety of fatty acids.¹³ Ceramides are sphingosine-based lipid second messenger (signaling) molecules that are involved in the regulation of diverse cellular responses to exogenous stimuli,¹⁴ and regulate multiple cellular functions such as proliferation, differentiation, and apoptosis.¹⁴ Decreased ceramide levels may contribute to the development of certain skin diseases such as atopic dermatitis. Hence, topical skin lipid supplementation may provide opportunities for controlling ceramide deficiency and improving skin condition.¹⁵

Sphingolipids or ceramides are liberally distributed as secondary metabolites in marine life. A large number of sphingolipids have been isolated from various marine organisms, including algae, sponges, sea anemones, sea stars, tunicates, soft corals, etc. Some sphingolipids have exhibited antitumor, immunostimulatory, antimicrobial, antiviral, Ca²⁺-ATPase activation, or phospholipase A2 inhibition activity.¹⁶ For example, novel glycosphingolipids containing iso-fatty acids were isolated along with galactosyl ceramides from the Oregon marine sponge *Halichondria panacea*.¹⁶ In addition, the isolation and structure elucidation of two unprecedented sulfonylated ceramides were reported. These were palyo-sulfonoceramide A and palyosulfonoceramide B from specimens of zoanthids (coral reefs) *Palythoa caribaeorum* and *Protopalythoa variabilis* collected off Brazil's northeastern coast.¹⁷

Fatty acids have multiple roles in the epidermis. They are found in bound form in triglycerides, phospholipids, glycosylceramides, and ceramides, which all play a vital role in formation of the epidermal permeability barrier.¹⁸ However, fatty acids in keratinocytes do not function only as building blocks. In addition to their well-known role in energy generation and storage, fatty acids can be potent signaling molecules.¹⁸

Eskimos traditionally eat a diet rich in fish and have very little psoriasis, but it does tend to develop when they eat a western diet with a higher intake of saturated fats.¹⁹

The content of free arachidonic acid (AA) in psoriatic lesions is increased 20-fold compared with uninvolved epidermis. A body of literature exists to support the relationship between psoriasis, the AA cascade, and omega-3 fatty acids. As an adjuvant to standard regimens, EPA (eicosapentaenoic acid) may have a role in the treatment of psoriasis.²⁰ EPA and docosahexaenoic acid (DHA) are omega-3 fatty acids found in oily fish and fish oil supplements. These fatty acids are able to partly inhibit several aspects of inflammation.²¹

Exopolysaccharide secreted by a deep-sea hydrothermal bacterium displays an interesting glycosaminoglycan-like feature resembling hyaluronan.²¹ This polysaccharide promotes collagen aggregation and facilitated fibroblast settling in the extracellular matrix, and mimics some properties of heparan-sulfate, such as the promotion of fibroblast proliferation and inhibition of matrix metalloproteinase (MMP) secretion. Therefore, this bacterium can be considered as an innovative biotechnological source of glycosaminoglycan-like compounds useful in the design of biomaterials and drugs for tissue engineering and repair.²¹

Consuming omega-3 fish oils eicosapentaenoic acid (EPA) and docosahexaenoic acid (DHA) may be inversely correlated with the development of skin cancer, although more research is needed before any conclusions can be made.²² EPA and DHA are found in seafood, including fatty fish (e.g., salmon, tuna, and trout) and shellfish (e.g., crab, mussels, and oysters). Clinical trials to examine the impact of the fish oils on the skin immunity of 79 healthy volunteers determined that taking a regular dose of fish oils boosted skin immunity to sunlight. Specifically, it reduced sunlight-induced suppression of the immune system (immunosuppression), which affects the body's ability to fight skin cancer and infection.²²

Shell extracts from the scallop (*Pecten maximus*), particularly in an acid soluble matrix, has effects on the synthesis of extra cellular matrix components and matrix remodeling. In human fibroblast cell culture, scallop shell nacre matrix components stimulated the synthesis of type I and III collagens, as well as that of sulfated glycosaminoglycans (GAGs).²³

Chitin and chitosan oligosaccharides and their derivatives (sourced from crustacean shells—shrimp/crab/lobster) also enhance a variety of dermatological applications. The continuous enzymatic production of various desirable molecular weight chitosan oligosaccharides increases the dermatological applications for utilizing these biomaterials.²⁴ New delivery systems and natural nano-compounds, such as

chitin nanofibrils for wound healing, are being used in cosmetic dermatology with good results, as are nanostructured TiO₂ and ZnO sunscreens.²⁵ Clinical observation obtained interesting results showing how chitin nanofibrils can ameliorate not only the appearance of photoaged skin but also promote wound healing by reducing hypertrophic scar formation.²⁶ *In vitro* studies demonstrated simultaneous reduction in lipid peroxides and transepidermal water loss. By using different types of emulsions, chitin showed how chitin nano-fibrils can increase the reproduction of fibroblasts, with a subsequent increase in collagen synthesis and in adenosine triphosphate production.²⁵ In an *in vivo* double-blind study, skin hydration and superficial skin lipids were improved, with nanofibrils having an interesting wound healing activity.^{25,27,28}

Many marine organisms and vegetals have demonstrated strong photoprotective effects in adapting to ultraviolet (UV) radiation.²⁹ Microsporine like amino acids (MAAs) are favored for photoprotective action because they have strong UV absorption (between 310 and 362 nm).³⁰

Sunscreen compounds are usually used to prevent the excessive damage caused by UVA and UVB. However, certain photosynthetic organisms have evolved mechanisms to counteract the toxicity of UV radiation by synthesizing UV screening compounds such as mycosporine-like amino acids (MAAs). MAAs provide UV protection to primary and secondary consumers through the food chain, and to non-biological materials by a photostabilizing action. Information related to the ecological consequence of MAAs and their spatial distribution from a wide range of organisms is accumulating. Hence, studies have sought a potent class of natural sun-protective compounds to understand their relationship with the environment and to develop a protocol for large-scale industrial production of these compounds, so that they can find applications as UV-protecting cosmetics.^{31,32}

It has been clinically validated that a potent antioxidant, astaxanthin (extracted from red oceanic plants and salmon), attenuates UV-induced upregulation of MMP-1 and skin fibroblast elastase in human dermal fibroblasts, thus enabling enhanced biomarine-active-based sun protection for future dermatological products.³³ Japanese researchers have examined the effects of astaxanthin (AX) on the induction of MMP-1 and skin fibroblast elastase (SFE) by UVA treatment of cultured human dermal fibroblasts. They found that UVA radiation elicited a significant increase in the gene expression of MMP-1 as well as SFE/neprilysin (NEP) (to a lesser extent), which was followed by distinct increases in their protein and enzymatic activity levels. The addition of AX at concentrations of 4–8 μM immediately after UVA exposure significantly attenuated the induction of MMP-1 and SFE/NEP expression elicited by UVA at the gene, protein, and activity levels, although both the UVA stimulation and the subsequent AX inhibition were greater for MMP-1 than for SFE/NEP. Analysis of the UVA-induced release of cytokines revealed that UVA significantly stimulated only the secretion of IL-6 among the cytokines tested, and that AX significantly diminished only the IL-6 secretion. They concluded that “AX would have a significant benefit on protecting against UVA-induced skin photo-aging such as sagging and wrinkles.”³³

Seaweeds

There are over 100,000 different species and sub-species of seaweeds in our oceans, ranging from single cell organisms to seaweeds over 150 ft long. They absorb nutrients from surrounding waters through their fronds. Broadly classified as brown, green, and red, they yield many pharmaceutical, cosmeceutical, and nutraceutical extracts and compounds, and are being actively researched for alternative biofuel applications.

Seaweed extracts are considerably higher in various vitamins, minerals, and amino acids than land plants, and are actually used as plant growth accelerators (plant food). They are a source of many skin-friendly nutrients such as polysaccharides (natural occurring polymers), lipids, glycolipids, nucleic acids, auxins, phlorotannins, and catchethins, etc., and are also rich in fatty acids (ceramides) and their glycosyl derivatives.

Certain oceanic environments are highly valued for their cold, fast flowing, particularly nutrient-rich and ideal seaweed growing environmental conditions. The Pacific Northwest, Tasmanian, Alaskan, and Northern Atlantic waters have also been internationally recognized for yielding high quality seaweeds.

Fuoidan

Several species of brown seaweeds contain biomolecules (sulfated polysaccharides), broadly referred to as fuoidan. Fuoidan contains galactose, glucuronic acid, xylose, and several other major constituents that give this substance its potential health benefits.

Fuoidan has demonstrated anticoagulant, antithrombotic, antiviral (anti RNA and DNA virus function), antitumor and immunomodulatory activity, antioxidant activity, blood lipids reduction, anticomplementary activity (innate and humoral immune response), heparin-like activity (similar ability to stimulate production of HGF), enhanced wound healing, anti-inflammatory, gastric protection (prevention of ulcers), and inhibition of cancer cells.³⁴

Fuoidan has significant enzyme inhibitory activity against a number of enzymes, including matrix metalloproteinases, hyaluronidases, and elastases. This inhibitory activity limits tissue breakdown in inflammatory settings caused by injury and disease and can even inhibit metastasis.^{35,36}

Fuoidan has several anti-inflammatory effects.³⁷ These include inhibition of acute and chronic inflammation via selectin (sugar-binding lectins found on the surface of cells that promote their adhesion to other cells and mediate their migration to sites of inflammation) blockade, enzyme inhibition, and inhibition of the complement cascade.³⁷ Further research has confirmed that *Undaria* derived fuoidan fractions inhibit human leucocyte elastase.³⁸ *Undaria* is also a particularly good fuoidan source for acne-prone skin because it is particularly low in iodine content compared to other species (iodides and bromides exacerbate acne). The Pacific Northwest species of *Undaria* is known as *Alaria*, and the Eastern Pacific version is known as *Ecklonia*.

Fuoidan has been investigated with respect to cell regeneration. It may support the persistence of stem cells to allow for better tissue regeneration. This leads to interest in tissue and organ revival. A study has concluded that the use of sulfated glycans including fuoidan promoted mobilization of long-term-repopulating stem cells.³⁹ Further, oral delivery of fuoidan from *Undaria pinnatifida* in a clinical study demonstrated an increase in the expression of stem cells.⁴⁰

Fuoidan has been shown to modulate the effects of a variety of growth factors through mechanisms thought to be similar to the action of heparin (anticoagulant). The interaction between two commercial preparations of fuoidan and transforming growth factor-beta 1 (TGFβ 1) was investigated. The preparations of fuoidan, as well as the heparin, inhibited fibroblast proliferation at concentrations from 0.01–100 mg/mL. In a three dimensional *in vitro* model of wound repair, the fibroblast populated collagen lattice or “dermal equivalent,” TGFβ 1 reduced the rate of fibroblast repopulation of a wound defect created by punch biopsy. Addition of fuoidan to the model in the presence of TGF-β 1 increased the rate of fibroblast repopulation of the wound, and at 10 mg/mL of fuoidan the number of cells which had migrated into the wounded defect was similar to that of control cultures. This data suggests that fuoidan has properties which may be beneficial in the treatment of wound healing.⁴¹ In another study, Japanese researchers developed a composite water-rich dressing sheet to improve the healing rate of diabetic wounds. In their diabetic animal model, the investigations proved that a dressing containing fuoidan significantly increased the rate of healing of wounds compared to commercially available dressings.⁴²

Topical application of *Fucus vesiculosus* extract on human facial skin was found to elicit a significant decrease in skin thickness (increased skin firmness) and an improvement in its mechanical properties—leading a Japanese team of researchers to conclude that *Fucus* extracts possess anti-aging properties. They determined that *F. vesiculosus* extracts were effective for cosmeceuticals targeting skin tightening, anti-sagging, and wrinkle smoothing.⁴³

A Korean group of researchers has assessed the effects of fuoidan on the inhibition of matrix metalloproteinases (MMPs). MMPs are responsible for degradation of the extracellular matrix, including collagen, elastin, gelatin, matrix glycoproteins, and proteoglycan. They focused on MMP-1 promoter activity and on the increase of type I procollagen synthesis in human skin fibroblasts. Fuoidan treatment significantly inhibited MMP-1 promoter activity compared to UVB irradiation alone. Fuoidan treatment also increased type I procollagen mRNA and protein expression in a dose-dependent manner compared to the control. Their data indicated that fuoidan may prevent UVB-induced MMP-1 expression and inhibited

the downregulation of type I procollagen synthesis. They suggest that fucoidan is a potential therapeutic agent for the prevention and treatment for photoaging of the skin.⁴⁴

Fucoidan has also been shown to be an effective alternative to cortisone for allergic dermatitis. Japanese research has determined that fucoidan mediated the suppression of IgE (allergen specific antibodies) in blood cells from patients with atopic dermatitis. The fucoidan formulation was shown to be as effective as dexamethasone, the commonly used corticosteroid treatment, which has significant drawbacks for long-term use.^{45,46}

Fucoidan is a rich source of polyphenols with potent superoxide inhibition, demonstrating significant antioxidant activity in experiments. They are excellent natural antioxidants and have a great potential for preventing free radical-mediated diseases.³⁴ Fucoidan research has been conducted pertaining to scavenger receptors. Scavenger receptors act as membrane-bound and soluble proteins that bind to macromolecular complexes and pathogens. In vascular tissues, scavenger receptors are implicated in regulating intracellular signaling, lipid accumulation, foam cell development, and cellular apoptosis or necrosis. Fucoidan has been found to bind to several scavenger receptors, thus inhibiting several receptor macrophages.⁴⁷

French researchers have demonstrated that fucoidan polysaccharides are able *in vitro* to stimulate dermal fibroblast proliferation and extracellular matrix deposition. Using tissue sections of human skin in *ex vivo* experiments, they also demonstrated that fucoidan is able to minimize human leukocyte elastase (enzyme that degrades a number of proteins including elastin) activity, resulting in the protection of the human skin elastic fiber network against the enzymatic proteolysis due to this serine proteinase. These results suggest that fucoidan could be used for treating some inflammatory pathologies in which uncontrolled extracellular matrix degradation takes place.³⁶

Fucoidan is also known to inhibit the pigment-forming enzyme tyrosinase. In a recently published study, researchers investigated this bioactivity of fucoidan and determined that fucoidan reversibly inhibited tyrosinase by binding to both the free enzymes and the enzyme-substrate complex.^{48,49}

In a Russian study, researchers demonstrated that fucoidan activates and binds to “toll-like receptors” in human cells. This activates a mediator called “NF- κ B” (a protein molecule that plays a key role in regulating the immune response to infection) to stimulate the body’s immune defenses. Researchers observed that this activity resulted in increases in cytokines, chemokines, and the expression of MHC molecules—demonstrating the activity of both adaptive and innate immune cells. The study found that fucoidan protects cells from pathogens by encouraging both innate and specific immune responses.⁵⁰ Although activation of toll-like receptors can also potentially lead to an over-inflammatory response, research into specific varieties of fucoidan such as *Ecklonia cava* has demonstrated strong anti-inflammatory activity.⁵¹

It is now widely accepted that some natural products can act synergistically to deliver enhanced activity. Fucoidan has been known to boost the efficacy of other bioactive compounds, creating the potential for more effective disease treatments. The potential exists for combining fucoidan with other natural bioactives to create even more effective complementary medicines.

Russian researchers determined that fucoidan and resveratrol had a strong synergistic effect when combined as potent anti-tumor agents in *in vitro* and *in vivo* studies.⁵² Canadian research, which was quantified through gene-chip analysis, demonstrated that fucoidan and noted immunity booster and wound healer beta glucan had a potent synergistic effect, activating several dermatological biomarkers over 20% glycolic acid controls; it was demonstrated that epidermal and dermal remodeling of the extracellular matrix results from glycolic acid treatment at a 20% concentration.⁵³ A synopsis of the gene-chip analysis on a biomarine active compound is contained in [Table 32.1](#).⁵⁴ Acidic formulations can be further aided with amplified action by the addition of vital marine extracts to fucoidan, because acids weaken the bridging of keranocytes by reducing protein synthesis. Therapeutic marine extracts enable a reduced inflammatory response, rapid wound healing, immunity boosting and growth factor stimulation, enhanced skin smoothing and hydration, and antioxidant protection, among a plethora of other genetically-validated dermatological biomarker enhancements.

In summary, biomarine actives are rapidly emerging as a biologically vital and valued cosmeceutical category for aiding in alleviating aging, allergy prone, photo-damaged, or compromised skin conditions.

TABLE 32.1

Gene-Chip Analysis of Biomarine Active Compound in 20% Glycolic Acid

Gene Symbol	Biomarker (Gene) Name	Function	Effect of 20% Glycolic Acid (The Control)	Effect of Biomarine Active Compound in 20% Glycolic Acid	Up-Down Regulation (Multiplier Effect)
<i>Genes that Influence Cellular Growth and Collagen Formation</i>					
CEP57	Centrosomal protein 57 kDa	Fibroblast growth factor receptor signaling pathway	56.8	252.09	4.44
COL18A1	Collagen, type XVIII, alpha 1	Collagen and collagen fibril organization	19.55	174.21	8.91
ADAM11	ADAM metalloproteinase domain 11	Metalloproteinase activity	29.37	186.06	6.33
ADAMTS1	ADAM metalloproteinase with thrombospondin type 1 motif, 1	Metalloproteinase activity	100.15	480.53	4.8
EGFR	Epidermal growth factor receptor	Epidermal growth factor receptor signaling pathway	48.2	211.43	4.39

REFERENCES

- Lambert P. Marine medicines: A chemical storehouse in the Sea RBCM discovery. *Discov Mag* 1994;22(3):1-2.
- Sewell A. Toxins, venoms and inhibitory chemicals in marine organisms. *Advanced Aquarist* 2007;VI: <http://www.advancedaquarist.com/2007/9/aafeature1>.
- Fassett RG, Coombes JS. Astaxanthin: A potential therapeutic agent in cardiovascular disease. *Mar Drugs* 2011;9(3):447-65.
- Park JS, Chyun JH, Kim YK, Line LL, Chew BP. Astaxanthin decreased oxidative stress and inflammation and enhanced immune response in humans. *Nutr Metab(Lond)* 2010;7:18.
- Tissot B, Montdargent B, Chevolut L et al. Interaction of fucoidan with the proteins of the complement classical pathway. *Biochim Biophys Acta*. 2003;1651(1-2):5-16.
- Varki A, Cummings RD, Esko JD et al. (eds). *Essentials of Glycobiology*. 2nd edn. Cold Spring Harbor, NY: Cold Spring Harbor Press: 2009.
- Popescu O, Checiu I, Gherghel P, Simon Z, Misevic GN. Quantitative and qualitative approach of glycan-glycan interactions in marine sponges. *Biochimie* 2003;85(1-2):181-8.
- Prescott B, Li CP. Abalone juice. Fractionation and antibacterial spectrum. *Proc Soc Exp Biol Med*. 1960;105:498-500.
- Li CP, Prescott B, Eddy B et al. Antiviral activity of paolins from clams. *Ann NY Acad Sci* 1965;130(1):374-82.
- Kohl A, Kerr R. Identification and characterization of the *Pseudopterostin diterpene* cyclase, elisabethatriene synthase, from the marine gorgonian, *Pseudopterogorgia elisabethae*. *Arch Biochem Biophys* 2004;424:97-104.
- Look SA, Fenical W, Jacobs RS, Clardy J. The pseudopterostins: Anti-inflammatory and analgesic natural products from the sea whip *Pseudopterogorgia elisabethae*. *Proc Natl Acad Sci USA* 1986;83(17):6238-40.
- Neh Onumah MD. A novel anti-inflammatory in treatment of acne vulgaris: The pseudopterostins. *J. Drugs Dermatol* 2013;12(10):1177-9.
- Coderch L, López O, de la Maza A, Parra JL. Ceramides and skin function. *Am J Clin Dermatol* 2003;4(2):107-29.

14. Kolesnick RN, Kronke M. Regulation of ceramide production and apoptosis. *Ann Rev Physiol* 1998;60:643–65.
15. Choi MJ, Maibach HI. Role of ceramides in barrier function of healthy and diseased skin. *Am J Clin Dermatol* 2005;6(4):215–23.
16. Muralidhar P, Radhika P, Krishna N, Venkata Rao D, Bheemasankara Rao Ch et al. Sphingolipids from Marine Organisms: A Review. Visakhapatnam, India: Andhra University, Department of Pharmaceutical Sciences; 1992.
17. Almeida JGL, Maia AIV, Wilke DV et al. Pseudo-polyunsulfonoceramides A and B: Unique sulfonated ceramides from the Brazilian Zoanthids *Palythoa caribaeorum* and *Protopalythoa*. *Mar Drugs* 2012;10(12):2846–2860.
18. Khnykin D, Miner J, Jahnsen F. Role of fatty acid transporters in epidermis—Implications for health and disease. *Dermatoendocrinol* 2011;3(2):53–61.
19. Burton JL. Dietary fatty acids and inflammatory skin diseases. 1989;333(8628):27–31.
20. Rackal J, Barankin B. The role of fish oils in psoriasis. *Br J Clin Pharmacol* 2013;75(3):645–62.
21. Calder PC. Omega-3 polyunsaturated fatty acids and inflammatory processes: Nutrition or pharmacology. *Br J Clin Pharmacol*. 2013;75(3):645–62.
22. Noel SE, Stoneham ACS, Olsen CM, Rhodes LE, Green AC. Consumption of omega-3 fatty acids and the risk of skin cancers: A systematic review and meta-analysis. *Int J Cancer* 2014;135(1):149–156.
23. Latire T, Legendre F, Bigot N et al. Shell extracts from the marine bivalve *Pecten maximus* regulate the synthesis of extracellular matrix in primary cultured human skin fibroblasts. *Plos One* June 20, 2014;9(6):e99931.
24. Barrow C, Shahidi F. ed. *Marine Nutraceuticals and Functional Foods*, Boca Raton, FL: CRC Press; Taylor & Francis; 2014.
25. Morganti P. Use and potential of nanotechnology in cosmetic dermatology. *Clin Cosmet Investig Dermatol* 2010;3:5–13.
26. Antonio JR, Antônio CR, Cardeal IL, Ballavenuto JM, Oliveira JR. Nanotechnology in dermatology. *An Bras Dermatol* 2014;89(1):126–36.
27. Biagini G, Zizzi A, Tucci G et al. Chitin nanofibrils linked to chitosan glycolate as spray, gel and gauze preparations for wound repair. *J Bioact Compat Polym* 2007;22:525–38.
28. Mezzana P. Clinical efficacy of a new chitin-nanofibrils based gel in wound healing. *Acta Chir Plast* 2008;50(3):81–84.
29. Pallela R, Young YN, Kim SK. Anti-photoaging and photoprotective compounds derived from marine organisms. *Mar Drugs* 2010;8(4):1189–1202.
30. Singh SP, Kunari S, Rastogi RP, Singh KL, Sinha RP. Microsporine-like amino acids (MAAs): Chemical structure, biosynthesis and significance. *Indian J Exp Biol* 2008;46:7–17.
31. Bhatia S, Garg A, Sharma K, Kumar S, Sharma A, Purohit AP. Mycosporine and mycosporine-like amino acids: A paramount tool against ultra violet irradiation. *Pharmacogn Rev* 2011;5(10):138–46.
32. Thomas NV, Kim SK. Beneficial effects of marine algal compounds in cosmeceuticals. *Mar Drugs* 2013;11(1):146–64.
33. Sukanuma K, Nakajima H, Ohtsuki M, Imokawa G. Astaxanthin attenuates the UVA-induced up-regulation of matrix-metalloproteinase-1 and skin fibroblast elastase in human dermal fibroblasts. *J Dermatol Sci* 2010;58(2):136–42.
34. Li B, Lu F, Wei X, Zhao R. Fucooidan: Structure and bioactivity. *Molecules* 2008;13:1671–95.
35. Thring TS, Hili P, Naughton DP. Anti-collagenase, anti-elastase and anti-oxidant activities of extracts from 21 plants. *BMC Complement. Altern Med* 2009;9:27.
36. Senni K, Gueniche F, Foucault-Bertaud A et al. Fucooidan a sulfated polysaccharide from brown algae is a potent modulator of connective tissue proteolysis. *Arch Biochem Biophys* 2006;445(1):56–64.
37. Fitton JH. Therapies from fucooidan; multifunctional marine polymers. *Mar Drugs* 2011;9:1731–60.
38. Katsube Y, Yamanaku Y, Iwamoto M, Oka S. Hyaluronidase—Inhibiting polysaccharide isolated and purified from hot water extract of sporophyll of *Undaria pinnatifida*. *Food Sci Technol Res* 2003;9(1):25–29.
39. Frenette PS, Weiss L. Sulfated glycans induce rapid hematopoietic progenitor cell mobilization: Evidence for selection-dependent and independent mechanisms. *Blood* 2000;96(7):2460–8.
40. Irhimeh MR, Fitton JH, Lowenthal RM. Fucooidan ingestion increases the expression of CXCR4 on human CD34+ cells. *Exp Hematol* 2007;35:989–94.

41. O'Leary R, Rerek M, Wood EJ. Fucoidan modulates the effect of transforming growth factor (TGF)-b 1 on fibroblast proliferation and wound repopulation *in Vitro* models of dermal wound repair. *Biol Pharm Bull* 2004;27(2):266–70.
42. Yanagibayashi S, Kishimoto S, Ishihara M et al. Novel hydrocolloid-sheet as wound dressing to stimulate healing-impaired wound healing in diabetic mice. *Biomed Mater Eng* 2012;22(5):301–10.
43. Fujimura T, Tsukahara K, Moriwaki S, Kitahara T, Sano T, Takema Y. Treatment of human skin with an extract of fucus vesiculosus changes its thickness and mechanical properties. *J Cosmetic Sci* 2002;53:1–9.
44. Moon HJ, Lee SH, Ku MJ et al. Fucoidan inhibited UVB-induced MMP-1 promoter expression and down regulation of Type I procollagen synthesis in human skin fibroblasts. *Eur J Dermatol* 2009;19(2):129–34.
45. Yang JH. Topical application of fucoidan improves atopic dermatitis symptoms in NC/Nga mice. *Phytother Res* 2012;26(12):1898–903.
46. Iwamoto K, Hiragun T, Takahagi S et al. Fucoidan suppresses IgE production in peripheral blood mononuclear cells from patients with atopic dermatitis. *Arch Dermatol Res* 2011;303(6):425–31.
47. Facciponte JG. *Characterization of Hsp 110 and Grp 170 Interactions with Scavenger Receptors*. Dissertation, Department of Immunology, Faculty of the Graduate School of New York, Buffalo, NY.
48. Wang ZJ et al. The effect of fucoidan on tyrosinase: Computational molecular dynamics integrating inhibition kinetics. *J Biomol Struct Dyn* 2012;30(4):460–73.
49. Jiménez JT, O'Connell S, Lyons H, Bradley B, Hall M. Antioxidant, antimicrobial, and tyrosinase inhibition activities of acetone extract of *Ascophyllum nodosum*. *Chemical Papers, Slovak Academy of Sciences*, 2010;64(4):434–42.
50. Makarenkova ID, Logunov DY, Tukhvatulin AI, Semenova IB, Besednova NN, Zvyagintseva TN. Interactions between sulfated polysaccharides from sea brown algae and toll-like receptors on HEK293 eukaryotic cells *In Vitro*. *Bull Exp Biol Med* 2012;154(2):241–4.
51. Lee SH, Ko CI, Jee Y et al. Anti-inflammatory effect of fucoidan extracted from *Ecklonia cava* in zebrafish model. *Carbohydr Polym* 2013;92(1):84–9.
52. Vishchuk OS, Ermakova SP, Zvyagintseva TN. The effect of sulfated (1→3)-alpha-1-fucan from the brown alga *Saccharina cichorioides* Miyabe on resveratrol-induced apoptosis in colon carcinoma cells. *Mar Drugs* 2013;11(1):194–212.
53. Bernstein EF, Lee J, Brown DB, Yu R, Van Scott E. Glycolic acid treatment increases type I collagen mRNA and hyaluronic acid content of human skin. *Dermatol Surg*. 2001;27(5):429–33.
54. Athwal G. Seaweed Derived Cosmetic Compositions. U.S. patent application 14/268,908 2014.

33

Analytical Chemistry of Botanical Extracts

Susan E. Ebeler and Alyson E. Mitchell

Introduction

There is both historical and increased current interest in the use of phytochemicals extracted from plant material (e.g., leaf, bark, seeds, fruit, etc.) as dietary supplements and cosmeceuticals to prevent and minimize the effects of degenerative diseases and aging.^{1,2} Numerous compounds extracted from plant materials have medical and/or beneficial effects on humans (i.e., bioactives which include cosmeceuticals) and are the subjects of other chapters in this volume. In addition, several articles reviewing approaches for the analysis and isolation of plant products and bioactives have previously been published.^{3–10} This chapter will emphasize chromatographic approaches for identifying and quantifying key bioactives in botanicals. These same approaches can also be used to confirm the authenticity, potency, and composition of botanicals, once the components and their mean concentrations have been established for a plant. While both gas chromatographic (GC) and high performance liquid chromatographic (HPLC) methods can be used for analysis of volatile and nonvolatile compounds, recent advances in hyphenated mass spectrometry (MS) detection have vastly improved our ability to quantify targeted known compounds and to identify unknown bioactives from plant extracts. Therefore, this chapter will emphasize these hyphenated GC-MS and HPLC-MS techniques, providing a brief background of their principles and reviewing a select number of applications. This chapter is not intended to give a comprehensive review of all methods published to date for analysis of botanicals. The goal is to provide the reader with an overview of contemporary chromatographic and mass spectrometric approaches used in the chemical characterization of botanical extracts.

Basic Approaches

Identification of bioactive components from botanicals is typically performed via a bioassay-guided fractionation process. This approach requires development and/or application of targeted bioassays, which are then used to monitor biological activity of plant fractions, extracts, and individual chemical components or mixtures. Numerous bioassays have been described that assess a range of biological activities, e.g., antioxidant activity, antimicrobial/antifungal activity, effects on cell growth and apoptosis, lipid biosynthesis, DNA damage, etc. It is beyond the scope of this chapter to outline these assays; however, a useful database published by the National Center for Biotechnology Information (NCBI) is available which allows for searching and screening of multiple biological tests by compounds, sources, taxonomy, outcomes, gene/protein targets, etc.¹¹

Once a plant material with reported biological activity has been selected and the desired bioassay/chosen, the general workflow is to obtain an initial crude extract by solvent extraction, size separation (e.g., ultrafiltration), and/or preparative chromatography, and then to purify it through chemical fractionation (Figure 33.1). During the process, each fraction is tested in the specified bioassay, and fractions with significant activity are subjected to further purification and separation. The composition of each fraction can be determined by chromatographic methods, with the ultimate goal generally being to identify a single compound or group of compounds that have activity in the bioassay. Chromatographic tools

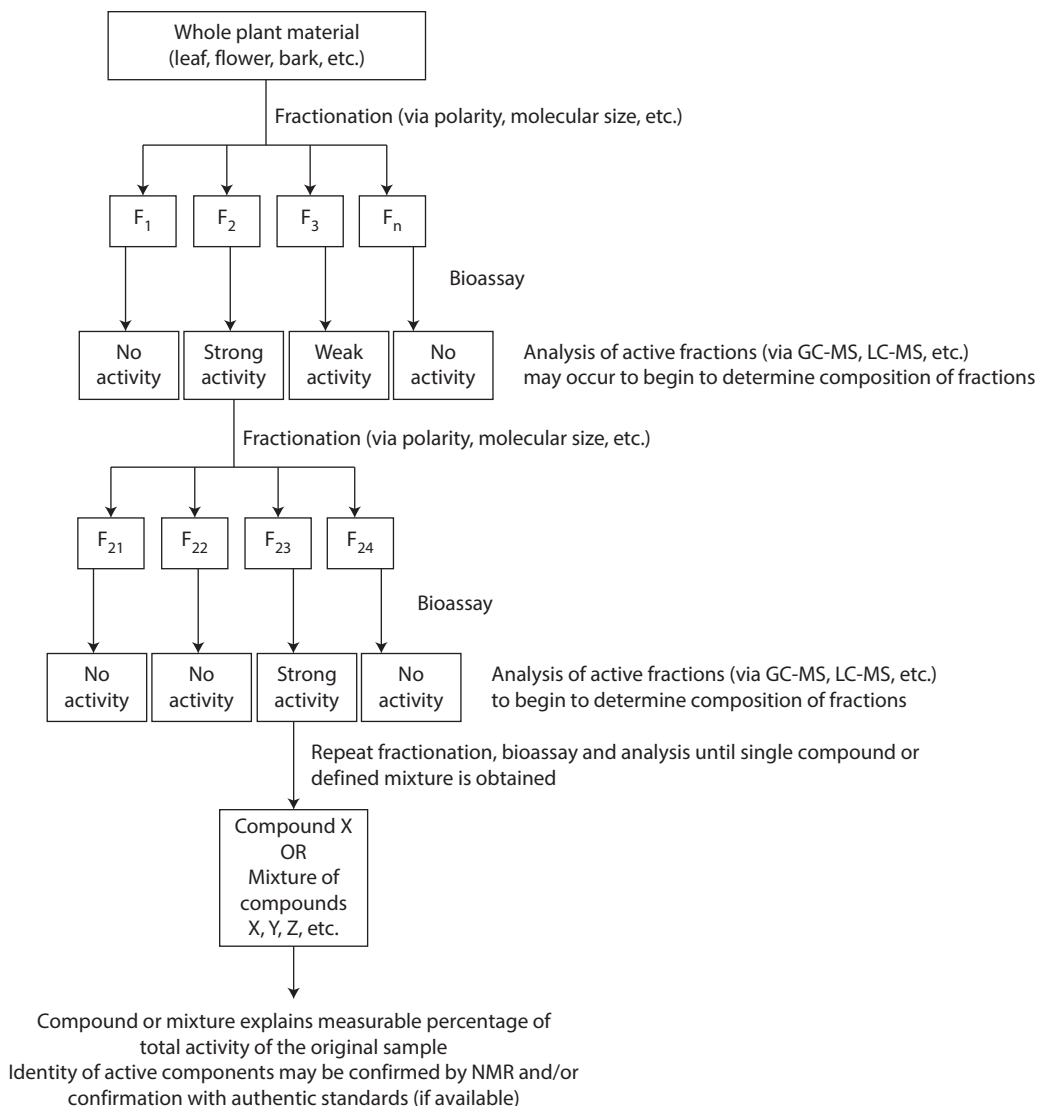

FIGURE 33.1 General scheme for bioassay guided fractionation of bioactive natural products.

coupled to detectors that provide mass and/or structural information are indispensable in this process.¹² In addition, if stable-isotope or radioactive-labeled compounds can be created, either via chemical synthesis or via labeling *in planta*, they can be used to identify and evaluate the efficacy and absorption of the bioactives in the bioassay.⁶

Confirmation of authenticity and composition of botanicals requires application of many of the same chromatographic and analytical tools. As reviewed by Takeoka and Ebeler,¹³ these methods must be sensitive and specific enough to accurately measure the natural variation in trace component composition that occurs among related species and as a result of geographic origin, seasonal effects, and processing or storage. Additionally, methods need to consider that the active ingredient(s) can exist with numerous and diverse chemical modifications (e.g., various glycosides, malonylated, acetylated forms, etc.). Lastly, methods need to be robust enough to encompass a wide range of raw plant materials (e.g., seeds, bark, leaf, etc.). For example, ginseng, used in traditional Chinese medicines as a stimulant, is now widely available as a range of commercial products. However, the active ingredients (ginsenosides) in

different ginseng species vary, and even within a species there can be wide variability in composition.¹⁴ Application of hyphenated chromatographic methods, particularly LC-MS, has been invaluable in profiling the chemical composition of ginseng products to confirm their authenticity (Figure 33.2) and provide quantitative information necessary to validate the potency of these natural products.¹⁵

With this background information in mind, we will provide a brief overview of chromatographic separations and the remainder of this chapter will then focus on the common and emerging chromatographic tools for identifying and quantifying the chemical composition of botanicals, either with the goal of identifying bioactive components (Figure 33.1) or of confirming authenticity/composition of botanicals.

Chromatography Overview

Chromatography involves separation of a mixture of two or more compounds into the component parts based on the differential affinity of the components for a stationary phase and a mobile phase. The separation can occur on a surface (planar chromatography; e.g., paper and thin layer chromatography [TLC]) or in a column (column chromatography). The types of column chromatography can be further distinguished by the nature of the stationary and mobile phases (Table 33.1). The choice of chromatographic methods will depend on the chemical and physical properties of the analyte(s) of interest, their chemical and thermal stability, and their concentrations in the sample.

In the early 1900s, Tswett described the separation of plant pigments via column liquid chromatography with a calcium carbonate packed stationary phase.^{16,17} Tswett's work demonstrated that the separation was based on adsorption of the pigments to the stationary phase and not via a simple filtration based on their molecular size. With this work, the science of chromatography was born, and over the intervening decades chromatographic approaches to separate, identify, and quantify increasingly complex mixtures were developed.

GC-MS

Introduced by James and Martin in the 1950s,^{18–24} gas chromatography (GC) is used for the analysis of volatile compounds (molecular weight <~450 Da, boiling point <300°C) in a wide variety of products. Analytes are introduced into the GC column via an inlet, vaporized, and separated based on differences in their vapor pressures and interactions with the stationary phase. Over the past 60 years, developments in GC have been combined with improvements in the separation columns that are used so that hundreds of compounds in a sample mixture can now be routinely resolved.

Numerous GC detectors are available (e.g., flame ionization, electron capture, nitrogen–phosphorous, chemiluminescent, etc.) offering a wide range of analyte selectivities and sensitivities. Mass spectrometers, which separate analyte ions based on the ratio of mass to charge, were developed in the early 1900s based on discoveries of Sir J. J. Thompson (reviewed by Griffiths²⁵). They were used as GC detectors shortly after GCs were introduced in the 1950s.^{26–28} Mass spectrometers require an ionization source to convert analyte molecules to ions (Table 33.2) and the ions then enter a mass analyzer at reduced pressure for separation and detection. There are several types of mass analyzers, the earliest developed being magnetic sector and time-of-flight instruments while transmission quadrupole and quadrupole ion trap detectors, conceived by Paul and Steinwedel,^{29,30} are now among the most widely used mass spectrometers (Table 33.3). An excellent overview of MS sources and analyzers is available online.³³

The development of affordable, user-friendly, and sensitive bench-top GC-MS detectors has made it possible to readily obtain mass and structural information for a wide variety of analytes, improving the ability to identify unknowns. As a result, GC-MS instruments are now routinely used for analysis of botanicals as demonstrated by a search of Google Scholar (terms “GC-MS analysis of botanicals”), which shows ~1900 publications in 2012 alone. Poole³⁵ provides a recent and comprehensive review of developments and applications of gas chromatography and GC-MS.

Recent studies of bergamot essential oils demonstrate the application of GC-MS for confirming composition, quality, and biological activity/toxicity of this important component in many cosmetics,

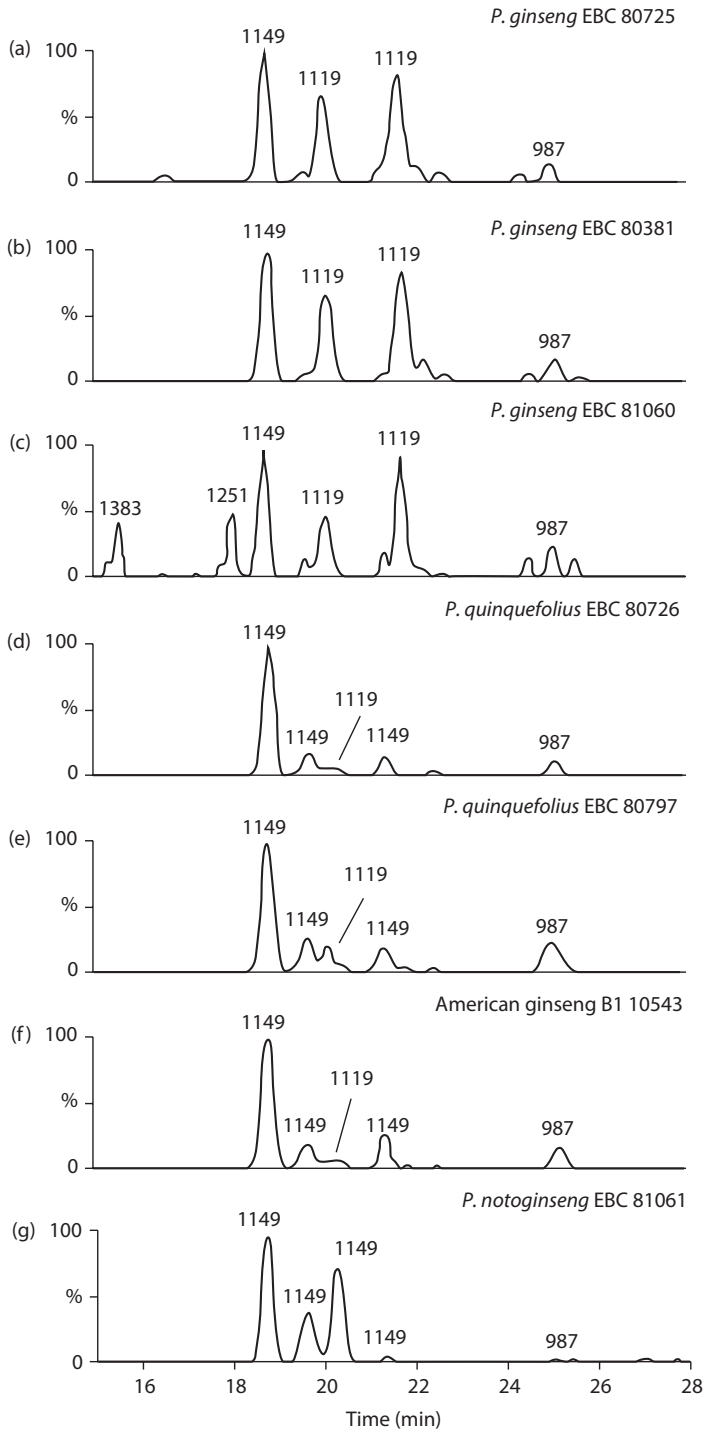

FIGURE 33.2 LC-MS analysis of selected major and minor malonyl-ginsenoside components in authentic samples of three ginseng species, *P. ginseng* (Asian ginseng; frames a–c), *P. quinquefolius* (American ginseng; frames d–e), and *P. notoginseng* (frame g). A commercial sample was confirmed to be American ginseng based on the chemical profile (frame f). (From Kite GC et al. *Rapid Comm Mass Spectrom* 2003;17:238–44. With permission.)

TABLE 33.1
Common Types of Column Chromatography

Type (Abbreviation)	Mobile Phase Properties	Liquid Phase Properties	Primary Separation Mechanism	Analyte Properties	Common Detectors
Gas-liquid (GLC or GC)	Gas (e.g., helium, hydrogen, nitrogen)	Immobilized liquid (e.g., polydimethylsiloxane; polyethylene glycol, etc.)	Partition; adsorption	Volatile; thermally stable ^a	Flame ionization; electron capture; flame photometric; nitrogen-phosphorous; chemiluminescence; Thermal conductivity; Mass spectrometry
Gas-solid (GSC)	Gas (e.g., helium, hydrogen, nitrogen)	Solid (e.g., charcoal; molecular sieves, etc.)	Adsorption; size exclusion	Gases; volatiles; thermally stable	Flame ionization; electron capture; flame photometric; nitrogen-phosphorous; Chemiluminescence; Thermal conductivity; Mass spectrometry
Liquid-liquid ^b (LC)	Liquid (e.g., buffers, organic solvents)	Immobilized liquid ^c (e.g., C ₁₈ and C ₃₀ hydrocarbons, diol, cyanopropyl, etc.)	Partition; adsorption	Nonvolatiles; acids; bases; hydrophobic compounds; thermally labile components	UV-visible; fluorescence; refractive index; electrochemical; Light scattering; mass spectrometry
Liquid-solid ^b (LC)	Liquid (e.g., nonpolar organic solvents)	Solid (e.g., alumina or silica)	Adsorption	Nonvolatiles; Polar compounds; thermally labile components	UV-visible; fluorescence; Refractive index; electrochemical; Light scattering; Mass spectrometry
Ion exchange ^b (IEC)	Liquid (e.g., buffers)	Solid with anionic or cationic ion exchange surface	Ion exchange; adsorption	Nonvolatiles; acids; bases; proteins, inorganic ions	UV-visible; fluorescence; Refractive index; electrochemical; Light scattering; Mass spectrometry
Size exclusion ^b (SEC)	Liquid (e.g., acids; bases; buffers)	Porous solid	Molecular size separation	Proteins; polymers	UV-visible; fluorescence; Refractive index; Electrochemical; Light scattering; Mass spectrometry

^a Chemical derivitization of some nonvolatile or thermally unstable compounds can make them amenable to GC analysis (e.g., conversion of fatty acids to methyl esters and conversion of sugars to trimethylsiloxane [TMS] adducts).

^b LC separations can be done at atmospheric pressure or under high pressures (e.g., high performance liquid chromatography, HPLC, and ultra high performance HPLC, UHPLC).

^c LC stationary phases are typically bound to a solid stationary support such as silica particles and cross-linked to improve stability.

TABLE 33.2
Types of Ionization Sources Used with Mass Spectrometers

Source	Chromatographic Interface	Basic Principle	Analyte Fragmentation
Electron ionization (EI)	GC	Gas phase analyte molecules (M) elute from the GC and are bombarded with high energy electrons (typically 70 eV) yielding a radical cation product: $M + e^- \rightarrow M^+ + 2e^-$	Yes
Chemical ionization (CI)	GC	A reagent gas (BH) (e.g., methane, ammonia) is introduced into the source, bombarded with high energy electrons to produce a charged reactant gas: $BH + e^- \rightarrow BH^+ + 2e^-$ The charged reactant gas is accelerated toward the gas phase analyte molecules (M) eluting from the GC and a proton is transferred from the reactant gas to the analyte: $M + BH^+ \rightarrow [M + H]^+ + B$	No or minimal
Negative ion CI (NICI)	GC	Electrons in an electron beam interact with a reagent gas (BH) resulting in either lower energy electrons which can be captured by the analyte molecules (M) or the negatively charged reaction ion is produced which reacts with the analyte (MH): $BH + e^- \rightarrow [B]^- + H^+ + e^-$ $M + e^- \rightarrow [M]^-$ (electron capture) OR $MH + [B]^- \rightarrow [M - H]^- + BH$ (CI)	No or minimal
Electrospray ionization (ESI)	HPLC/UHPLC	Eluent from HPLC column is sprayed through a capillary and across a high potential difference resulting in charged droplets. The spray is heated to desolvate the eluent and as the droplet size decreases, the droplets explode via a "Coulombic" explosion, resulting in singly or multiply charged analyte ions. Analyte may be multiply charged making this technique amenable to macromolecules (e.g., proteins and DNA); protonated and deprotonated molecules (i.e., $[M + H]^+$ or $[M - H]^-$) may form depending on ionizing voltage applied, i.e., positive or negative	No or minimal
Atmospheric pressure chemical ionization (APCI)	HPLC/UHPLC	Eluent from HPLC is heated to high temperature and gaseous aerosol is ionized by a corona discharge. Protonated and deprotonated molecules may form (i.e., $[M + H]^+$ or $[M - H]^-$) depending on ionizing voltage, i.e., positive or negative; Analyte may be multiply charged $[M + nH]^{n+}$	No or minimal (but fragmentation may be greater than with ESI due to higher temperature during ionization)
Matrix assisted laser desorption (MALDI)	Static/HPLC/UHPLC	Analytes (M) are dissolved/co-crystallized in a matrix (e.g., sinapic acid, 2,5-dihydroxy benzoic acid, etc.) and a drop of the mixture is placed on a surface. A laser is directed at a matrix/analyte mixture. The matrix absorbs energy, desorbs from the surfaces, and some matrix molecules are ionized (protonated). The charge is then transferred from the matrix to the analyte yielding protonated and deprotonated molecules (i.e., $[M + H]^+$ or $[M - H]^-$) depending on ionizing voltage and matrix; Analyte may be multiply charged $[M + nH]^{n+}$	No or minimal

TABLE 33.3

Types of Mass Analyzers^a

Analyzer Type	Principle	Resolution ^b
Magnetic sector	Accelerated ions enter a magnetic field (B) and travel within a circular path with a radius proportional to the m/z . $m/z = B^2 r^2 / 2V$ (V is the accelerating voltage) Either the magnetic field strength and/or the accelerating voltage is varied and ions are monitored/detected as they exit the analyzer.	30,000
Time-of-flight	Ions with different m/z are accelerated to the same kinetic energy (KE). The accelerated ions travel along a flight tube at different velocities (v) proportional to the ratio of mass (m) to charge (z): for $z = 1$, $v = (2KE/m)^{1/2}$ and $m = 2t^2 \times KE/d^2$. According to these relationships, different ion masses can be distinguished by the time they take to travel a given distance.	8000–60,000 (depending on configuration and flight path tube length)
Transmission quadrupole	Four cylindrical metal rods are arranged parallel to each other. A radio frequency (RF) and direct current (DC) voltage are applied alternately across the rods. Ions oscillate in the field with a frequency dependent on their m/z . As the RF voltage is varied, only ions of a specific m/z will have a stable trajectory through the quadrupoles to the detector.	4000
Quadrupole ion trap (Paul ion trap)	Ions are trapped in a ring electrode with two end cap electrodes. An RF field is applied to the trap; by scanning the RF field, ions of a given m/z are excited, ejected through a small aperture in one of the end caps, and detected.	4000
Fourier transform-ion cyclotron resonance	An ion in a magnetic field will rotate with an angular frequency (ω) proportional to the magnetic field (B). The angular frequency is inversely proportional to the ion mass (m): $\omega = zB/m$. The ions are excited and their rotation induces a charge (or image current) that is detected at two plates. The voltage between the plates is measured as a function of time. All ions are detected simultaneously, and ions with different cyclotron frequencies (i.e., different m/z) are extracted mathematically through a Fourier-transform calculation.	100,000–>1,000,000 (depending on magnetic field strength)
Accelerator MS	Ions are accelerated (millions of electron volts) to extremely high kinetic energies and then separated in a magnetic field. Used for analysis of isotopes of selected elements, e.g., ¹⁴ C.	¹⁴ C/ ¹³ C ratio selectively determined with high sensitivity ^c

^a Ions leaving the analyzer are detected; the most common detector is an electron multiplier. Faraday cups or gas ionization detectors are often used with accelerator MS.

^b Resolution defined as $m/\Delta m$; m = mass of ion, Δm = mass difference needed to resolve two peaks (at 50% of the maximum peak height). Reported resolutions from Arnaud,³¹ Holcapek et al.,³² Scripps.³³ For definitions see also Murray et al.³⁴

^c Atomic isobars that do not form negative ions are suppressed (e.g., ¹⁴N suppressed in ¹⁴C measurements); molecular isobars fragment during stripping step (e.g., ¹³CH⁻ stripped in ¹⁴C measurements).

perfumes, beverages, and pharmaceuticals.^{36–38} Bergamot essential oil is typically obtained by cold-pressing the rind of *Citrus bergamia* fruit and its addition to Earl Grey tea contributes to the characteristic citrusy/floral aroma of this beverage. Using GC-MS, 83 volatile constituents have been identified in bergamot essential oil; monoterpenes are the most abundant components and contribute to the distinctive aroma.^{38,39} Based on GC-MS analysis, the terpene content of the oil has been shown to change throughout the growing season, from year to year, and as a function of geographic origin.^{36–38} Importantly, the composition can also change as a result of processing (e.g., distillation) and the concentration ratio of two terpenes, linalyl acetate, and linalool has been proposed as a marker of processing conditions and subsequent quality.³⁶

Several of the terpenes in bergamot essential oils are chiral and the enantiomeric ratios can be analyzed by GC-MS with a chiral separation column. As reviewed by Ebeler,⁴⁰ enantiomeric composition can be used to authenticate foods and beverages with respect to source (e.g., plant genus and species;

TABLE 33.4

Enantiomeric Ratios of Selected Monoterpenes in Bergamot Essential Oils Determined by GC-MS

Compound	Enantiomeric Excess in Cold-Pressed Oil	Enantiomeric Excess in Processed Oil ^a
R-(–)-linalool	>99	94–98
R-(–)-linalyl acetate	>99	>98
R-(+)-limonene	>97	>98
R-(–)- α -thujene	>99	>99
S-(–)- β -pinene	>90	>90
1S,4R-(–)-camphene	>80	>80
S-(–)- α -pinene	65–76	67–72
S-(–)-sabinene	80–85	82–85
R-(+)- α -terpineol	35–79	91–96

Source: Data from Dugo G et al. *J Essent Oil Res* 2012;24:93–117.

Note: All except (+)- α -terpineol may be useful for authentication of cold-pressed oil.

^a Distilled, cold-pressed oil.

natural vs. synthetic), geographic origin, and processing conditions. As reported by Dugo et al.,³⁸ the enantiomeric purities of eight monoterpenes are characteristic of genuine bergamot oils (Table 33.4) while the ratios of (–)-linalool and (+)- α -terpineol may vary with processing conditions. Melliou et al.³⁷ also reported that thermal treatment during distillation increases (–)-linalool isomerization resulting in production of (+)-linalool.

Finally, cold-pressed bergamot essential oils contain the psoralen (furocoumarin) photosensitizer, bergapten (5-methoxypsoralen). Topical application of bergapten to skin combined with UV light exposure induces irritation and is mutagenic and tumorigenic in animal studies,^{41–44} therefore bergapten-free essential oils are desired.* Vacuum distillation of the citrus peel or the cold-pressed oil is effective in removing bergapten and related psoralins and coumarins.^{36,38} The presence of bergapten can be readily monitored during processing by GC with FID or MS detection.^{36,46}

HPLC and HPLC-MS

The classical liquid chromatographic separations of Tswett, which used coarse stationary phase particles and separations at atmospheric pressures, became widely adopted for the analysis of pigments and natural products in the decades after 1906. During this period, detectors that allowed colorless compounds to be measured were developed and procedures were devised to couple the detectors to the end of the column so that analytes could be detected as they eluted from the column.⁴⁷ The theories of partition chromatography and the advantages of small stationary phase particles, immobilized stationary phases, and elevated pressures during separation were first advanced in the field of gas chromatography in the 1950s but not until the 1960s and 1970s were these concepts widely applied to liquid chromatographic separations. During this time the development of mechanically stable adsorbents, nonpolar stationary phases (e.g., C₁₈), stainless steel columns, and high and ultra high pressure pumps that uniformly delivered mobile phase solvents helped to make high performance liquid chromatography (HPLC) and more recently ultra high performance liquid chromatography (UHPLC) among the most widely used analytical techniques for analysis of biological samples.^{48–53} HPLC, first described in 1967 by Csaba Horváth and colleagues,^{52,53}

* The International Fragrance Association (IFRA) recommends that total levels of bergapten should not exceed 15 ppm in consumer products used on skin. Levels of bergamot oils should not exceed 0.4% in leave-on consumer products applied to skin exposed to sunlight (IFRA⁴⁵).

uses pressures of up to 6000 psi (400 bar). UHPLC technology, introduced in 2004, took advantage of further advances in instrumentation and column technology and allows for columns with smaller particles (<2 μm) and instrumentation designed to deliver a mobile phase at 15,000 psi (1000 bar).

The liquid mobile phases of HPLC make the use of MS detectors challenging, since large amounts of solvent must be removed and the analytes need to be ionized and converted to a gaseous phase prior to introduction into the mass detector. Early approaches (e.g., fast atom bombardment, plasma desorption, thermospray) were not very sensitive and did not effectively ionize large molecules.²⁵ The electrospray ionization (ESI) source (Table 33.2), developed in the 1980s⁵⁴ revolutionized the field and HPLC-(ESI) MS is now one of the most widely used techniques for the analysis of nonvolatile biological molecules.^{25,48–51,55} With ESI, a large variety of chemical substances, encompassing a wide range of polarities, can be ionized with essentially no mass restrictions.

There is increasing interest in use of natural products and extracts with antioxidant activity as anti-aging products, either for oral consumption (supplements) or topical application (reviewed by Pouillot et al.⁵⁶). Among natural antioxidants, a range of phenols and carotenoids have been widely studied and numerous methods for their analysis by HPLC-(ESI)MS exist. In a recent study, Zhao et al.⁵⁷ used a bioassay-guided fractionation of *Pyracantha fortuneana* fruit, combined with HPLC-(ESI)MS, to identify polyphenol components that have antioxidant activity. Long used in traditional Chinese diets, *P. fortuneana* has been associated with a variety of biological activities, including antioxidant, antibacterial, skin whitening, and anti-aging effects.

In the study of Zhao et al.,⁵⁷ a crude extract was obtained by ethanolic extraction (71% ethanol, pH 3.2) of *P. fortuneana* fruit. The crude extract was dried and re-suspended in water before further fractionating with solvents of increasing polarity: hexane, ethyl acetate, and n-butyl alcohol. The antioxidant activity of the crude extract and each fraction, including the water phase, was monitored using the ferric reducing antioxidant potential (FRAP) assay.* Antioxidant activity was observed in all fractions, however, compared to the original aqueous ethanol extracted product, only about 65% of the total activity was recovered in the subsequent fractions. Since the total extractable solids yield of the four fractions was 98%, these results indicate that some antioxidant activity may have been lost during fractionation (e.g., through oxidation or hydrolysis) and/or that other nonphenolic substances with little antioxidant activity, (e.g., polysaccharides) were present in the crude extractions and subsequent fractions. The greatest antioxidant activity was observed in the ethyl acetate fraction. Interestingly, the authors did not observe any antagonistic (or synergistic) interactions between the individual fractions (which would have been observed as a significant increase [or decrease] in activity of one or more fractions when analyzed separately as compared to the original extract). In general, the antioxidant activity appeared to be associated with the total polyphenol content, rather than one or a small number of compounds, i.e., the entire crude ethanolic fraction is needed for maximum antioxidant activity.

Using HPLC-(ESI)MS analysis, 27 polyphenols were found in the *P. fortuneana* extracts including flavonols, anthocyanins, proanthocyanins, and gallic acid-based tannins. Many of these compounds were identified for the first time in this fruit. Using the HPLC-(ESI)MS data to obtain the nominal mass and fragment ion information, tentative assignments could be made by matching to published HPLC-(ESI) MS databases. The identity of seven compounds was then confirmed by matching HPLC-(ESI)MS data of the unknown peaks to that of authentic standards. The identity of several compounds could not be confirmed, however, due to the presence of isomers with identical nominal molecular weights in the databases and since authentic standards were not available. In some cases, potential structures could be eliminated based on dissimilarities in the UV/vis spectra, however, in other cases, further structural characterization with tandem mass spectrometry (MS/MS) was required, and will be discussed in the following section.

These results demonstrate the power of HPLC-MS profiling to monitor the composition of botanicals and to identify compounds with biological activity. However, when authentic standards are not available to confirm analyte identity, as is often the case in natural product research, the limitations of HPLC-MS data in identification of unknowns, particularly those with similar UV/vis spectra and

* Numerous assays for measuring antioxidant activity of natural products exist, each with advantages and limitations.^{58,59} It is beyond the scope of the current review to evaluate the choice of antioxidant assays used for this study.

nominal (unit) mass are also evident. These limitations have therefore led to increasing application of chromatography coupled with tandem mass spectrometry and high-resolution mass spectrometry for analysis of botanicals.

Tandem Mass Spectrometry (MS/MS)

Tandem MS, also known as MS/MS, was first proposed in 1978 as a way to enhance structure elucidation and analysis of complex mixtures, as compared to single MS analyzers.⁶⁰ Tandem MS utilizes multiple sequential stages of mass analysis that enable the selection of ions of a given mass produced in the source, fragmentation of these ions and analysis of the mass spectrum of the fragments produced (de Hoffman 1996).⁶¹ The first tandem MS instruments used a series of sequential quadrupole mass filters, although other configurations are often now used (e.g., ion traps; Table 33.3). For example, in a product ion scan experiment, ions of a selected mass are passed through the first mass filter (MS1) and enter into a collision cell where they are reacted with an inert gas to induce analyte fragmentation. This process is referred to as either collision-induced dissociation (CID) or collision-activated dissociation (CAD). The final mass filter (MS2) is then set to allow only selected fragments from the collision cell to pass through and be detected. Several types of MS/MS experiments can be performed (Figure 33.3; reviewed by Ebeler⁶²) and different instrument configurations allow the ions either to travel through the mass separators and collision cell sequentially in space, or in the case of ion-trap instruments, an ion trap manipulates the precursor ions in time to sequentially perform the functions of MS1, the collision cell, and MS2.

In above example of *P. fortuneana* fruit analysis,⁵⁷ HPLC-MS/MS was used to tentatively identify a hydrolysable tannin component. Based on a nominal mass of m/z 786, determined by HPLC-MS, several possible formulas and structures are possible. Using MS/MS to fragment the molecular ion and scan for product ions, ions of m/z 635 and 485 were observed, consistent with the loss of gallic acid fragments

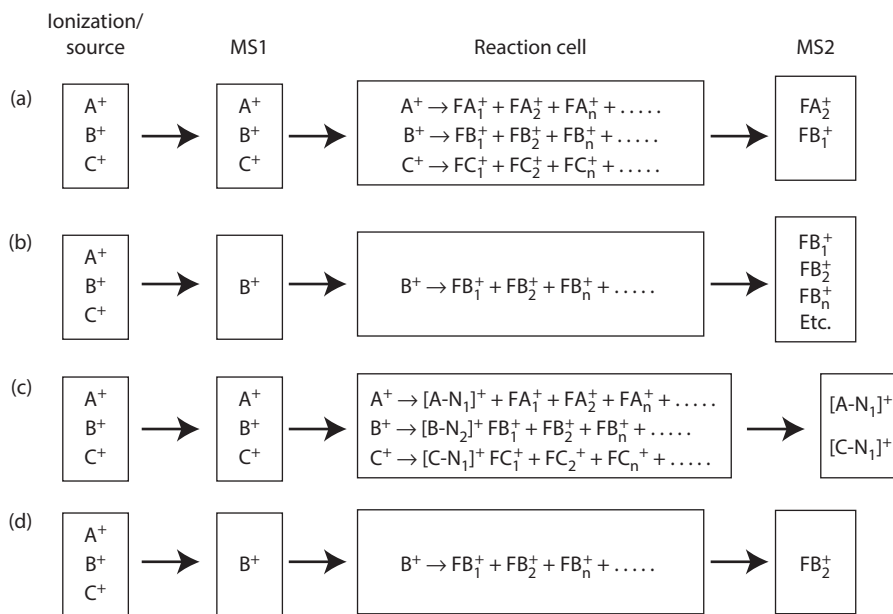

FIGURE 33.3 Schematic of the various types of MS/MS experiments. A^+ , B^+ , C^+ are precursor analyte ions; FA_1^+ , FA_2^+ , FB_1^+ , etc., are product ion fragments produced from the corresponding precursor analyte ions. Neutral fragments are designated as N_1 , N_2 , N_3 , etc. (a) Precursor ions from MS1 enter reaction cell and only selected fragment masses are monitored in MS2; (b) only selected precursor ions enter MS1 and are reacted in the collision cell, MS 2 monitors all subsequent fragment masses; (c) precursor ions from MS1 enter reaction cell and only fragments with a constant neutral mass loss from the precursor ions are monitored in MS2; (d) MS1 and MS2 monitor only specific pre-identified masses.

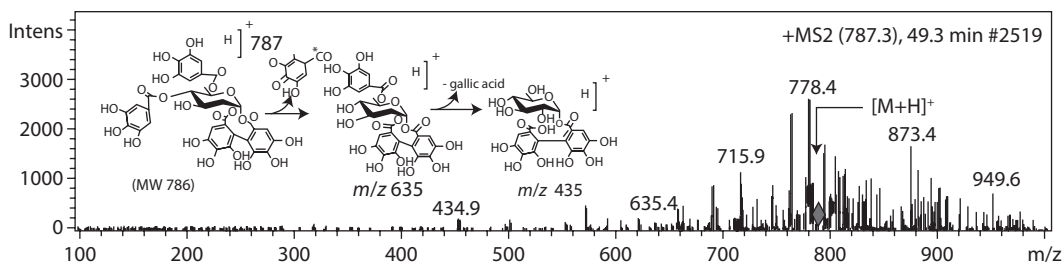

FIGURE 33.4 LC MS/MS spectrum of bis-hexahydroxydiphenolic acid-glucoside. The protonated molecular ion $[M + H]^+$ at m/z 787 is denoted with a diamond and arrow. (From Zhao CF et al. *J Funct Foods* 2013;5:715–28. With permission.)

from a hexahydroxydiphenolic gallic acid glucoside. This information, along with comparison of the spectra to literature and database spectra, led the authors to propose the tentative structure shown in Figure 33.4, although some ambiguity in the conformation of the linkages remains.

Tandem MS, when combined with HPLC or GC, is also a powerful tool for the targeted profiling of known components in a variety of plant, food, botanical, and cosmeceutical matrices. The sequential mass filtering that occurs is effective at removing “noise” and unwanted masses from the spectrum so that only selected analyte masses are monitored with a high degree of sensitivity and selectivity (Figure 33.3a). As an example, Du et al.⁶³ used HPLC-MS/MS to simultaneously profile and quantify 20 of the major and minor bioactive diterpenoids and phenolic acids in samples of *Isodon nervosa*, a Chinese herb used to treat skin itching and eczema, among other diseases. Authentic standards were used to optimize the MS/MS analysis conditions and to create calibration curves for analyte quantification. The analysis time was relatively fast (15 minutes) and the method required minimal sample preparation (methanol extraction of powdered sample followed by filtering through a 0.45 μm membrane). Twenty-one *I. nervosa* samples from different sources were analyzed and the results indicated that the amount of the bioactives was highly variable and dependent on the geographical origin and method of cultivation as well as the plant part tested. The results demonstrate the potential of tandem MS as an analytical tool for rapid and sensitive monitoring of product quality and standardization.

High-Resolution Mass Spectrometry

Most quadrupole mass analyzers are able to resolve ions with unit (nominal) mass differences (e.g., m/z 154 and 155). For a given nominal mass, multiple chemical formulas (and potential molecular structures) may be possible, with the number of possible formulas increasing exponentially as the mass increases. High-resolution mass analyzers, on the other hand, with resolutions of $\sim 10,000$ or greater³² (Table 33.3), make it possible to determine the accurate mass of analytes, significantly limiting the number of possible chemical formulas. This can allow for unknown analysis in which the data captured is accurate enough to determine the elemental composition of the compounds of interest therefore allowing tentative identification without standards. For example, m/z 154 corresponds to eight different molecular formulas containing C, H, O, and N in the METLIN data base, while m/z 154.1358 corresponds only to the formula $\text{C}_{10}\text{H}_{18}\text{O}$, a monoterpene.⁶⁴ Although not sufficient to completely eliminate possible molecular compositions,⁶⁵ high-resolution capability significantly enhances the ability to identify unknown compounds and confirm sample composition. Several types of high-resolution time-of-flight (TOF) and FT-ICR instruments are now commercially available and widely used for a number of applications in natural product research.^{31,66}

When combined with chromatography and tandem mass spectrometry, the ability of high-resolution mass analyzers to identify unknowns is increased even further. In the example above, using m/z 154.1358, numerous potential structures/compounds are possible (e.g., citronellal, linalool, lavandulol, isoborneol, etc.). However, since these compounds have different structures they can be distinguished based on their chromatographic retention times and distinct MS/MS fragmentation patterns. As noted previously,

however, without authentic standards to confirm structures, some ambiguity in compound identification still remains and enantiomers can only be distinguished by chiral separations. Other techniques such as NMR can be used to increase the probability of identification.

In a recent example, Sun et al.⁶⁷ used UHPLC with high-resolution TOF-MS/MS to discriminate between *Aconitum* species and botanical parts of the plant. *Aconitum kusnezoffi* and *Aconitum carmichaelii* roots are used in traditional Chinese medicines as a topical or oral analgesic and as a cardiotoxic.^{68–70} Alkaloids in the plant tissues are highly toxic, however, and prior to use as a medicinal treatment, the plants are processed by soaking and boiling to hydrolyze the toxic components.^{68,69} In traditional Chinese medicine, the processed roots used as an herbal drug are called Chuanwu/Caowu (processed from the main root of *A. carmichaelii*) and Fuzi/Shenfuzi (processed from the lateral root of *A. carmichaelii*).^{67,69} *Aconitum* is used in various other herbal mixtures (e.g., Yin Chen Si Ni Tang),⁷⁰ and analytical methods to characterize different species and different plant parts are needed to ensure optimal efficacy while minimizing toxicity of these herbal treatments.

High-resolution TOF MS instruments enable investigators to extract all possible compounds found in the single MS data and then filter the found “unknown compounds” or “entities” based on their presence in one sample and absence in another. This allows the investigator to differentiate between samples (e.g., plant parts, varieties, growing regions, etc.) based upon a MS fingerprint. Filtering the MS data should include not only the presence or absence of entities, but relative concentrations of unknowns as well. This complex extraction or mining of the data may provide differentiation without having to actually identify the actual distinguishing compounds. This approach is known as *nontargeted* or *unknown profiling*. For example, using a nontargeted profiling approach, methanol extracts from the roots of the two different *Aconitum* species discussed above were readily distinguished, as were extracts of the main root and lateral root of *A. carmichaelii*.⁶⁷ In the nontargeted analysis, chromatographic peaks are initially labeled only by their retention time and mass. Although a large number of unique entities could be distinguished in the analysis, overall the qualitative compositional profile of the two sample types was similar. However, by comparing differences in the peak area ratios of 22 entities, the different root parts could be distinguished. The compositional profile of the two different species was also qualitatively different, and 13 components were important for distinguishing between the species, with three components being present only in *A. carmichaelii*. Based on the nontargeted profiles, the entities determined to be important for differentiating the samples were further identified based on their accurate mass and MS/MS profiles and comparison to spectral information in published databases. Interestingly, *A. kusnezoffia* had the highest concentrations of the toxic alkaloids aconitine, mesaconitine, and hypaconitine. It is important to note that the roots used in this study were not detoxified by heat treatment prior to extraction and analysis. Whether the differences in composition in the analyzed samples were due to genetic differences or to differences in growing conditions, maturity, or other factors is not possible to determine from this study. However, the UHPLC-QTOF-MS method provides a rapid method (~12 minutes) for further monitoring of the effects of genetic, environmental, and processing effects on the composition of this botanical.

Analysis of Metabolites

The above sections have discussed analysis of components in botanicals, however, for these compounds to have true bioactivity (efficacy) they need to be absorbed into the body. Once absorbed, the compounds of interest may be extensively metabolized through Phase 1 and Phase 2 biotransformation reactions. These reactions can involve conjugation reactions (e.g., glucuronidation, sulfation, methylation, and glutathionylation) as well as oxidation, reduction, and hydrolysis reactions. Considerable *in vitro* evidence indicates that it is often one or more of the metabolites that have the biological activity and that the biological activity of these metabolites depends on the type and position of the conjugate group on the parent compound. Conjugation can also decrease biological activity.

For example, the dietary phenol, quercetin, has antioxidant, anticarcinogenic, and anti-inflammatory activity and is widely present in fruits and vegetables as a mixture of glycoside derivatives.⁷¹ Apple and onion are rich sources of quercetin glycosides, but the bioavailability of quercetin varies due to differences in the quercetin glycosides profiles of these foods. In a recent study, application of UHPLC-QTOF

MS/MS facilitated the identification and sensitive quantification of quercetin metabolites in human plasma over 24 hours following consumption of applesauce enriched with either micronized apple peel or onion powder.⁷² Using this analytical approach, fifteen different quercetin metabolites were identified in plasma, including the first report of a plasma quercetin glutathione adduct. In addition, the study showed that while the range of metabolites found in plasma was similar for apple and onion following consumption, total absorption of quercetin glycosides (measured as plasma concentrations of quercetin metabolites over 24 hours, $AUC_{0-24\text{ h}}$) and the maximum plasma metabolite concentrations (C_{max}) were greater for onion powder compared to consumption of apple peel.⁷² Overall, the high sensitivity and selectivity of the UHPLC-QTOF MS/MS analysis provided an improved understanding of the metabolic fate of dietary sources of quercetin glycosides relative to previous reports.

Analytical methods for measuring bioactives following dermal absorption are the same as those discussed previously. For example, due to their prevalence in fragrances, dermal absorption of terpenes is of significant interest⁷³ and in a recent study, GC-MS enabled individual terpenes from a lemon essential oil (*Citrus limon*, Burm. f.) to be monitored as they penetrated through a reconstructed human epidermis model.⁷⁴ Significant penetration of limonene, α -pinene, and *p*-cymene was observed; however, the penetration lag time and skin permeability coefficient were different for each compound and the composition of the formulation (oil/water and water/oil emulsions) influenced the penetration kinetics. The presence of the essential oil also enhanced the absorption of lipid and water-soluble vitamins (vitamins E, B6, C, and retinyl acetate) present in the formulations as determined by HPLC measurements.

Following absorption, the metabolic processes in skin are similar to those of liver and other tissues (e.g., oxidation, reduction, hydrolysis, and conjugation reactions via Phase 1 and Phase 2 enzymes).⁷⁵⁻⁷⁷ However, studies on the metabolism of specific plant bioactives following dermal exposure are limited and metabolism in the skin tissue can be difficult to differentiate from liver metabolism *in vivo*.^{76,78} An understanding of this cutaneous metabolism is critical since it can influence bioactivity and bioavailability both locally and systemically.⁷⁸ Studies with skin subcellular fractions, inducible keratinocyte cell lines (e.g., HaCats), and isolated skin tissue can be used to evaluate metabolic processes in the skin.⁷⁶ However, Maxwell et al.⁷⁹ have noted that sensitive and selective methods are still needed to measure intra- and extra-cellular concentrations of chemicals and their metabolites in order to fully assess the bioavailability of the chemical following dermal exposure. The majority of studies to date have used radioactively labeled compounds to monitor cutaneous metabolism of natural and synthetic products, following dermal absorption.⁸⁰⁻⁸² The high sensitivity and resolution of TOF and FT-ICR mass analyzers and accelerator mass spectrometry make these approaches particularly useful for analysis of metabolites and pharmacokinetic studies,^{72,83-86} however, their application has not been extensively explored for metabolism in skin tissue.

Analyte Quantification and Sample Preparation

Any chemical analysis requires careful consideration of analyte quantification and sample preparation. In the case of analyte quantification, the ideal method is to add an internal standard (IS) to the sample prior to sample preparation and analysis. The IS helps to correct for analyte losses during sample preparation, matrix suppression or enhancement during MS ionization, and differences in detector response factors for different analytes. The choice of internal standards is critical and the IS should match as closely as possible the chemical and physical properties of the analyte/s. For this purpose stable isotope labeled internal standards are ideal, if available. Accurate quantification also requires use of authentic analyte standards for calibration; if authentic standards are not available, only relative quantification is possible. The difficulties associated with quantification when authentic standards are not available was recently demonstrated by Lee et al.⁷² in the study of *in vivo* metabolism of quercetin glycosides from apples and onions. In this study the ionization mode used in the MS significantly impacted the response and the predominant metabolites that could be observed. For example, quercetin glucuronide sulfate was the predominant metabolite measured in negative ESI mode while quercetin glucuronide and quercetin diglucuronide were the predominant metabolites measured in positive ESI mode. A quercetin glutathione adduct could only be observed in negative mode. Without authentic standards to evaluate ionization efficiencies, the absolute amounts of these compounds in plasma could not be determined, however.

Sample preparation can also have a significant impact on the analytes present and measured in the sample. Any sample preparation method will have some selectivity and should be chosen with care to maximize analyte recovery while minimizing matrix interferences. Sample preparation methods for GC analysis have been reviewed⁶² and include techniques that sample only volatiles in the headspace above a sample (e.g., solid phase microextraction or SPME) and various types of liquid/liquid extractions. Solid phase extractions (SPE) are widely used for both GC and HPLC sample preparation and selectively remove matrix components based on their relative polarity or charge, depending on the type of SPE stationary phase used. General reviews of sample preparation for HPLC-MS analysis are available.^{87,88} In general, sample preparation methods should be carefully chosen to meet the objectives of the analysis and in some cases, more than one sample preparation may be needed in order to obtain the most complete information.⁶²

Summary

Chromatographic and mass spectrometric approaches are widely used for the analysis of natural product composition. Tandem MS when combined with HPLC and GC can be used for the highly sensitive and selective analysis of bioactive ingredients in order to confirm species, geographic origin, processing conditions, etc. High-resolution mass analyzers offer unparalleled opportunities to identify unknown compounds and to do nontargeted profiling for sample characterization and classification.

While these techniques have led to an improved understanding of the composition and bioactivity of botanicals and cosmeceuticals, future research focused on developing methods for identifying metabolites and monitoring their composition following dermal exposure and/or oral consumption are needed. This information is critical for a complete understanding of the bioavailability and bioactivity of plant phytochemicals. In addition, further development of rapid, high-throughput and cost effective analyses are necessary in order to aid in standardizing the composition and ensuring the quality and efficacy of large numbers of botanicals and commercial products. Finally, a main challenge in the analysis of bioactives remains the limited availability of authentic reference materials for confirming compound identity and concentration. Reliable sources of well-characterized standards, as well as cost-effective approaches for isolation of pure compounds, are needed. Once available, these compounds and isolation methods will significantly improve our ability to identify novel bioactive compounds and to accurately monitor the levels of bioactive components in botanicals with important health protective effects.

REFERENCES

1. Dayan N, Kromidas L. *Formulating, Packaging, and Marketing of Natural Cosmetic Products*. Hoboken, NJ: John Wiley & Sons; 2011.
2. Mukherjee PK, Maity N, Nema NK et al. Bioactive compounds from natural resources against skin aging. *Phytomed* 2011;19:64–73.
3. Hostettmann K, Wolfender JL, Rodriguez S. Rapid detection and subsequent isolation of bioactive constituents of crude plant extracts. *Planta Med* 1997;63:2–10.
4. Xing J, Xie C, Lou H. Recent applications of liquid chromatography-mass spectrometry in natural products bioanalysis. *J Pharm Biomed Anal* 2007;44:368–78.
5. Barnes S, Birt DF, Cassileth BR et al. Technologies and experimental approaches at the National Institutes of Health Botanical Research Centers. *Am J Clin Nutr* 2008;84(suppl):472S–80S.
6. Weaver CM, Barnes S, Wyss JM et al. Botanicals for age-related diseases: From field to practice. *Am J Clin Nutr* 2008;87(Suppl):493S–7S.
7. Marston A, Hostettmann K. Natural product analysis over the last decades. *Planta Med* 2009;75:672–82.
8. Costa R, Dugo P, Santi L et al. Advances of modern gas chromatography and hyphenated techniques for analysis of plant extracts. *Curr Org Chem* 2010;14:1752–68.
9. Gafner S, Villinski JR. Chromatographic techniques for the analysis of natural products in cosmetics. In: Dayan N, Kromidas L, eds. *Formulating, Packaging, and Marketing of Natural Cosmetic Products*. Hoboken, NJ: John Wiley & Sons; 2011, pp. 331–60.

10. Nakabayashi R, Saito K. Metabolomics for unknown plant metabolites. *Anal Bioanal Chem* 2013;405:5005–11.
11. NCBI. National Center for Biotechnology Information: Chemicals and Bioassays. Accessed online July 13, 2013. <http://www.ncbi.nlm.nih.gov/guide/chemicals-bioassays/>.
12. Wolfender JL, Marti G, Queiroz F. Advanced in techniques for profiling crude extracts and for the rapid identification of natural products: Dereplication, quality control and metabolomics. *Curr Org Chem* 2010;14:1808–32.
13. Takeoka GR, Ebeler SE. Progress in authentication of food and wine. In Ebeler SE, Takeoka GR, Winterhalter P, ed. *Progress in Authentication of Food and Wine*. ACS Symposium Series 1081. Washington, DC: American Chemical Society; 2011, pp. 3–11.
14. Harkey MR, Henderson GL, Gershwin ME et al. Variability in commercial ginseng products: An analysis of 25 preparations. *Am J Clin Nutr* 2001;73:1101–6.
15. Kite GC, Howes MJR, Leon CJ et al. Liquid chromatography/mass spectrometry of malonyl-ginsenosides in the authentication of ginseng. *Rapid Comm Mass Spectrom* 2003;17:238–44.
16. Tswett M. Physikalisch-chemische Studien über das chlorophyll. Die adsorptionen. *Ber Deutsch Botanisch Ges* 1906;24:316–23.
17. Tswett M. Adsorptionanalyse und chromatographische methode. Anwendung auf die Chemie des Chlorophylls. (Adsorption analysis and chromatographic method. Application to the chemistry of chlorophyll.) *Berichte der Deutschen Botanischen Gesellschaft* (Reports of the German Botanical Society) 1906;24:384–93.
18. James AT. Gas-liquid partition chromatography: The separation of volatile aliphatic amines and of the homologues of pyridine. *Biochem J* 1952;52:242–7.
19. James AT, Martin AJP. Gas-liquid partition chromatography: The separation and micro-estimation of volatile fatty acids from formic acid to dodecanoic acid. *Biochem J* 1952;50:679–90.
20. James AT, Martin AJP, Smith GH. Gas-liquid partition chromatography: The separation and micro-estimation of ammonia and the methylamines. *Biochem J* 1952;52:238–42.
21. James AT, Martin AJP. Gas-liquid chromatography: A technique for the analysis and identification of volatile materials. *Br Med Bull* 1954;10:170–6.
22. Martin AJP, James AT. Gas-liquid chromatography: The gas-density meter, a new apparatus for the detection of vapours in flowing gas streams. *Biochem J* 1956;63:138–43.
23. James AT, Martin AJP. Gas-liquid chromatography: The separation and identification of the methyl esters of saturated and unsaturated acids from formic acid to *n*-octadecanoic acid. *Biochem J* 1956;63:144–52.
24. James AT, Martin AJP. The separation and identification of some volatile paraffinic, naphthenic, olefinic, and aromatic hydrocarbons. *J App Chem* 1956;6:105–15.
25. Griffiths J. A brief history of mass spectrometry. *Anal Chem* 2008;80:5678–83.
26. Gohlke RS. Time-of-flight mass spectrometry and gas-liquid partition chromatography. *Anal Chem* 1959;31:535–41.
27. Rhyage R. Use of a mass spectrometer as a detector and analyzer for effluents emerging from high temperature gas liquid chromatography columns. *Anal Chem* 1964;36:759–64.
28. Gohlke RS, McLafferty FW. Early gas chromatography/mass spectrometry. *J Am Soc Mass Spectrom* 1993;4:367–71.
29. Paul W, Steinwedel H. Ein neues Massenspektrometer ohne Magnetfeld. (A new mass spectrometer without a magnetic field.) *Z Naturforsch* 1953;8a:448–50 (in German).
30. Borman S, Russell H, Siuzdak G. A mass spec timeline. *Today's Chemist at Work* 2003;September:47–9.
31. Arnaud CH. Hi-res mass spec. *C&E News* 2010;88(25):10–15.
32. Holcapek M, Jirasko R, Lisa M. Recent developments in liquid chromatography-mass spectrometry and related techniques. *J Chromatogr A* 2012;1259:3–15.
33. Scripps Center for Metabolomics and Mass Spectrometry. “What Is Mass Spectrometry?” Accessed online July 9, 2013. http://masspec.scripps.edu/mshistory/whatisms_details.php#Basics.
34. Murray KK, Boyd RK, Eberlin MN et al. Definitions of terms relating to mass spectrometry (IUPAC Recommendations 2013). *Pure Appl Chem* 2013;85:1515–609.
35. Poole CF. *Gas Chromatography*. Oxford: Elsevier; 2012.
36. Belsito EL, Carbone C, Di Gioia ML et al. Comparison of the volatile constituents in cold-pressed bergamot oil and a volatile oil isolated by vacuum distillation. *J Agric Food Chem* 2007;55:7847–51.

37. Melliou E, Michaelakis A, Koliopoulos G et al. High quality bergamot oil from Greece: Chemical analysis using chiral gas chromatography and larvicidal activity against the West Nile virus vector. *Molecules* 2009;14:839–49.
38. Dugo G, Bonaccorsi I, Sciarrone D et al. Characterization of cold-pressed and processed bergamot oils by using GC-FID, GC-MS, GC-C-IRMS, enantio-GC, MDGC, HPLC and HPLC-MS-IT-TOF. *J Essent Oil Res* 2012;24:93–117.
39. Sawamura M, Onishi Y, Ikemoto J et al. Characteristic odour components of bergamot (*Citrus bergamia* Risso) essential oil. *Flav Fragr J* 2006;21:609–15.
40. Ebeler SE. Enantiomeric analysis as a tool for authentication of foods and beverages. In: Ebeler SE, Takeoka G, Winterhalter P, eds. *Authentication of Food and Wine*, ACS Symposium Series 952. Washington, DC: American Chemical Society; 2007, pp.39–49.
41. Blog FB, Szabo G. The effects of psoralen and UVA (PUVA) on epidermal melanocytes of the tail of C57BL mice. *J Invest Dermatol* 1979;73:533–7.
42. Ashwood-Smith MJ, Poulton GA, Barker M et al. 5-Methoxypsoralen, an ingredient in several suntan preparations, has lethal mutagenic and clastogenic properties. *Nature* 1980;285:407–9.
43. Young AR, Walker SL, Kinley JS et al. Phototumorigenesis studies of 5-methoxypsoralen in bergamot oil: Evaluation and modification of risk of human use in albino mouse skin model. *J Photochem Photobiol B* 1990;7:231–50.
44. US Food and Drug Administration (FDA), Suntan Products. In *Cosmetic Product Manufacturers: Guide to Inspections of Cosmetic Product Manufacturers*. Silver Spring, MD: US FDA, 2009, Accessed online July 4, 2013. <http://www.fda.gov/ICECI/Inspections/InspectionGuides/ucm074952.htm>.
45. International Fragrance Association (IFRA), *IFRA Standards Booklet* (46th Amendment), Brussels: IFRA Operations; 2009.
46. Cardoso CAL, Vilegas W, Honda NK. Rapid determination of furanocoumarins in creams and pomades using SPE and GC. *J Pharm Biomed Anal* 2000;22:203–14.
47. Ettre LS. The rebirth of chromatography 75 years ago. *LC-GC North America* 2007;25:640–55.
48. Pitt JJ. Principles and applications of liquid chromatography-mass spectrometry in clinical biochemistry. *Clin Biochem Rev* 2009;30:19–34.
49. Pullen F. The fascinating history of the development of LC-MS; a personal perspective. *Chromatography Today* 2010;February/March:4–6.
50. Shackleton C. Clinical steroid mass spectrometry: A 45-year history culminating in HPLC-MS/MS becoming an essential tool for patient diagnosis. *J Ster Biochem Molec Bio* 2010;121:481–90.
51. Unger KK, Ditz R, Machtejeva E et al. Liquid chromatography—Its development and key role in life science applications. *Angew Chem Int Ed* 2010;49:2300–12.
52. Horváth C, Preiss BA, Lipsky SR. Fast liquid chromatography. Investigation of operating parameters and the separation of nucleotides on pellicular ion exchangers. *Anal Chem* 1967;39:1422–8.
53. Ettre LS. Csaba Horváth and the development of the first modern high performance liquid chromatograph. *LC-GC North America* 2005;23:486–95.
54. Fenn JB, Mann M, Meng CK, Wong SF, Whitehouse CM. Electrospray ionization for mass spectrometry of large biomolecules. *Science* 1989;246:64–71.
55. Konermann L, Ahadi E, Rodriguez AD et al. Unraveling the mechanism of electrospray ionization. *Anal Chem* 2013;85:2–9.
56. Pouillot A, Polla LL, Tacchini P, Neequaye A, Polla A, Polla B. Natural antioxidants and their effects on the skin. In Dayan N, Kromidas L, eds. *Formulating, Packaging, and Marketing of Natural Cosmetic Products*. Hoboken, NJ: John Wiley & Sons; 2011, pp.239–57.
57. Zhao CF, Li S, Li SJ et al. Extraction optimization approach to improve functional fraction based on combination of total polyphenol, chromatographic profiling and antioxidant activity evaluation: *Pyracantha fortuneana* fruit as an example. *J Funct Foods* 2013;5:715–28.
58. Huang D, Ou B, Prior RL. The chemistry behind antioxidant capacity assays. *J Agric Food Chem* 2005;53:1841–56.
59. Prior RL, Wu X, Schaich K. Standardized methods for the determination of antioxidant capacity and phenolics in foods and dietary supplements. *J Agric Food Chem* 2005;4290–302.
60. Yost RA, Enke CG. Selected ion fragmentation with a tandem quadrupole mass spectrometer. *J Am Chem Soc* 1978;100:2274–5.

61. de Hoffman E. Tandem mass spectrometry: A primer. *J Mass Spectrom* 1996;31:129–37.
62. Ebeler SE. Gas chromatographic analysis of wines: Current applications and future trends. In Poole CF, ed. *Gas Chromatography*. New York: Elsevier, 2012, pp.689–710.
63. Du Y, Jin Y, Liu P et al. Rapid method for simultaneous determination of 20 components in *Isodon nervosa* by high-performance liquid chromatography-electrospray ionization tandem mass spectrometry. *Phytochem Anal* 2010;21:416–27.
64. Scripps Center for Metabolomics. METLIN: Metabolite and tandem MS database. Accessed online July 24, 2013. <http://metlin.scripps.edu/index.php>.
65. Kind T, Fiehn O. Metabolomic database annotations via query of elemental compositions: Mass accuracy is insufficient even at less than 1 ppm. *BMC Bioinformatics*, 2006;7:234.
66. Marshall AG, Hendrickson CL. High-resolution mass spectrometers. *Annu Rev Anal Chem* 2008;1:579–99.
67. Sun H, Wang M, Zhang A et al. UPLC-Q-TOF-HDMS analysis of constituents in the root of two kinds of *Aconitum* using a metabolomics approach. *Phytochem Anal* 2013;24:263–76.
68. So YT, Fung HT, Chung KL et al. A case of Chuanwu and Fuzi poisoning. *Hong Kong J Emerg Med* 2000;7:230–3.
69. Chan TY. Aconite poisoning. *Clin Toxicol (Phila)* 2009;47:279–85.
70. Yan G, Sun H, Sun W et al. Rapid and global detection and characterization of *aconitum* alkaloids in Yin Chen Si Ni Tang, a traditional Chinese medical formula, by ultra performance liquid chromatography-high resolution mass spectrometry and automated data analysis. *J Pharm Biomed Anal* 2010;53:421–31.
71. Erlund I. Review of the flavonoids quercetin, hesperetin, and naringenin. Dietary sources, bioactivities, bioavailability, and epidemiology. *Nutr Res* 2004;24:851–74.
72. Lee J, Ebeler SE, Zweigenbaum JA et al. UHPLC-(ESI)QTOF MS/MS profiling of quercetin metabolites in human plasma postconsumption of applesauce enriched with apple peel and onion. *J Agric Food Chem* 2012;60:8510–20.
73. RIFM Expert Panel, Belsito D, Bicker D et al. A toxicologic and dermatologic assessment of cyclic and non-cyclic terpene alcohols when used as fragrance ingredients. *Food Chem Tox* 2008;46:S1–S71.
74. Valgimigli L, Gabbanini S, Berlini E et al. Lemon (*Citrus limon*, Burm. f.) essential oil enhances the trans-epidermal release of lipid-(A,E) and water-(B6, C) soluble vitamins from topical emulsions in reconstructed human epidermis. *Int J Cosmet Sci* 2012;34:347–56.
75. World Health Organization. *Dermal Absorption. Environmental Health Criteria*, 235. Geneva Switzerland: WHO Press; 2006.
76. Williams FM. Potential for metabolism locally in the skin of dermally absorbed compounds. *Hum Exp Toxicol* 2008;27:277–80.
77. Svensson CK. Biotransformation of drugs in human skin. *Drug Metabol Dispos* 2009;37:247–53.
78. Esser C, Gotz C. Filling the gaps: Need for research on cell-specific xenobiotic metabolism in the skin. *Arch Toxicol* 2013;87(10):1873–5.
79. Maxwell G, Aleksic M, Davies M et al. Skin sensitization: Modeling the human adverse response. *Proceedings of the 8th World Congress on Alternatives and Animal Use in the Life Sciences*, Montreal, 2011, pp.225–9.
80. Ford RA, Hawkins DR, Mayo BC et al. The *in vivo* dermal absorption and metabolism of [4-¹⁴C]coumarin by rats and by human volunteers under simulated conditions of use in fragrances. *Food Chem Tox* 2001;39:153–62.
81. Hawkins DR, Elsom LF, Kirkpatrick D et al. Dermal absorption and disposition of musk ambrette ketone and musk xylene in human subjects. *Toxicol Lett* 2002;131:147–51.
82. Traynor MJ, Wilkinson SC, Williams FM. Metabolism of butoxyethanol in excised human skin *in vitro*. *Toxicol Lett* 2008;177:151–5.
83. Turteltaub KW, Vogel JS. Bioanalytical applications of accelerator mass spectrometry for pharmaceutical research. *Curr Pharm Des* 2000;6:991–1007.
84. Vuong LT, Buchholz BA, Lame MW et al. Phytochemical research using accelerator mass spectrometry. *Nutr Rev* 2004;62:375–88.
85. Ramanathan R. *Mass Spectrometry in Drug Metabolism and Pharmacokinetics*. Hoboken, NJ: John Wiley & Sons; 2009.

86. Lappin G, Stevens L. Biomedical accelerator mass spectrometry: Recent applications in metabolism and pharmacokinetics. *Expert Opin Drug Metab Toxicol* 2008;4:1021–1033.
87. Henion J, Brewer E, Rule G. Sample preparation for LC/MS/MS: Analyzing biological and environmental samples. *Anal Chem* 1998;70:650A–6A.
88. Ashri NY, Abdel-Rehim M. Sample treatment based on extraction techniques in biological matrices. *Bioanalysis* 2011;3:2003–18.

34

Legal Distinction in the United States between a Cosmetic and a Drug

Peter Barton Hutt

The Federal Food, Drug, and Cosmetic Act (FD&C Act) establishes substantially different regulatory requirements in the United States for cosmetics and drugs. This chapter traces the history of U.S. regulatory policy for these two categories of products, discusses the application of U.S. law to products that fall within both categories at the same time (i.e., cosmetic drugs), and considers potential strategies for resolving the long-standing concern that the drug provisions of the Act impose overly stringent requirements on cosmetic drugs. The term “cosmeceutical” has no legal or regulatory meaning and no other accepted definition, and is therefore not used in this chapter.

Historical Overview

Cosmetic products have been used by humans since before recorded history. Archeologists date the earliest discovered cosmetics to about 10,000 BC.¹ By the height of the ancient Roman civilization, virtually all types of cosmetics that are available today were in widespread use. In his landmark *Natural History*, Pliny the Elder (23–79 AD) described such cosmetic products as hair dye, eyelash dye, eyebrow dye, freckle removers, rouge, deodorants and antiperspirants, depilatories, wrinkle removers, hair preservatives and restorers, bust firmers, sunburn products, complexion aids, moisturizers, mouthwashes and breath fresheners, toothpaste, face powder, and perfume.² Cosmetics have continued to be widely used from these ancient times to the present.

During the 19th century, virtually all government regulation of private enterprise in the United States was conducted at the city, county, and state levels. Because of the Supreme Court’s narrow interpretation of the power of the federal government to regulate interstate commerce, federal laws regulating consumer products did not emerge until the first decade of the 20th century. Thus, the first laws explicitly regulating cosmetics were enacted by the states. The earliest known state regulatory law explicitly mentioning cosmetics was enacted by Massachusetts in 1886. This law included all cosmetics within the statutory definition of a drug, thus imposing the same regulatory requirements on both cosmetics and drugs.³

From 1879 through 1906, Congress held hearings and debated the enactment of a federal food and drug law.⁴ Although bills introduced in Congress during 1898–1900 explicitly defined the term “drug” to include all cosmetics,⁵ the inclusion of cosmetics was deleted from the drug definition in 1900 as part of a legislative compromise.⁶ As a result, cosmetics were not included when the legislation was finally enacted as the Federal Food and Drugs Act of 1906.⁷

Implementation of the 1906 Act was delegated by Congress to the U.S. Department of Agriculture (USDA). Subsequently, it was redelegated to the Federal Security Agency (FSA), then to the Department of Health, Education, and Welfare (DHEW), and now to the Department of Health and Human Services (HHS). Since 1930, the specific agency responsible for the 1906 Act and its successor statute, the FD&C Act of 1938,⁸ has been the Food and Drug Administration (FDA).⁹ For editorial purposes, throughout this chapter, all references to the agencies and departments responsible for implementing federal food and drug laws shall be to FDA.

Not long after enactment of the 1906 Act, FDA concluded that its jurisdiction should be expanded to include both cosmetics and medical devices.¹⁰ When the Franklin D. Roosevelt Administration introduced a bill to replace the 1906 Act,¹¹ cosmetics were included¹² through a separate definition and separate regulatory requirements. Although the provisions relating to cosmetics were revised periodically during the five years of congressional consideration, the separate definition and separate regulatory requirements were retained in the final FD&C Act when it was enacted in 1938.⁹ In the intervening 76 years, these provisions have not been amended.

Legislative History of the Cosmetic and Drug Provisions of the 1938 Act

The 1906 Act¹³ defined a drug to include:

... all medicine and preparations recognized in United States Pharmacopoeia or National Formulary for internal or external use, and any substance or mixture of substances intended to be used for the cure, mitigation, or prevention of disease of either man or other animals.

From the time that the legislation that ultimately became the FD&C Act was initially introduced until it was finally enacted, substantial attention was focused on the specific definitions of food, drug, and cosmetic, and the interaction among these three definitions. Out of these deliberations, the following important principles and policies emerged.

First, the 1938 Act, like the 1906 Act, classified products according to their intended use. In a paragraph from the 1935 Senate Report¹⁴ on the legislation, Congress established the policy that the representations of the sellers with respect to a product would determine its classification:

The use to which the product is to be put will determine the category into which it will fall. If it is to be used only as food it will come within the definition of food and none other. If it contains nutritive ingredients but is sold for drug use only, as clearly shown by the labeling and advertising, it will come within the definition of drug, but not that of food. If it is sold to be used both as a food and for the prevention or treatment of disease it would satisfy both definitions and be subject to the substantive requirements for both. The manufacturer of the article, through his representations in connection with its sale, can determine the use to which the article is to be put. For example, the manufacturer of a laxative which is a medicated candy or chewing gum can bring his product within the definition of drug and escape that of food by representing the article fairly and unequivocally as a drug product.

This principle remains the touchstone for product classification under the 1938 Act.

Second, from the outset, FDA sought to expand the definition of a drug from the narrow definition included in the 1906 Act. The 1906 Act limited the drug definition to products intended to prevent or treat disease. FDA was concerned that, although it was able to regulate food products represented for use in weight reduction, it could not exert jurisdiction over nonfood chemicals represented for the same purpose because obesity was not regarded as a disease. Accordingly, from the initial bill to the final law, the drug definition was expanded to include articles “intended to affect the structure or any function of the body of man or other animals.”¹⁵

Third, Congress determined that the definitions of “food,” “drug,” and “cosmetic” should not be mutually exclusive. Because the representations made for a product would determine the proper classification of the product, and thus classification was within the sole control of the seller, Congress concluded that the product should be subject to whatever statutory requirements are established for whatever product classifications applied, on the basis of those representations¹⁴:

It has not been considered necessary to specify that the definitions of food, drug, and cosmetic shall not be construed, other than to the extent expressly provided, as mutually exclusive. The present law does not have such a clause relating to the definitions of food and drug and there has

never been a court decision to the effect that these definitions are mutually exclusive, despite the fact that repeated actions have been brought, for example, against filthy foods bearing unwarranted therapeutic claims, alleging these products to be adulterated as food because of their filth, and misbranded as drugs because of their false and fraudulent therapeutic claims.

Thus, dual and even triple classifications of a product as a food, drug, and cosmetic were contemplated by Congress under the 1938 Act.

Congress realized that there must be one exception to the general rule of nonexclusive definitions. All food is intended to affect the structure or function of the human body. Accordingly, Congress explicitly excluded food from the structure/function prong of the drug definition, but not from the disease prong.

In the Senate debate on the legislation in April 1935, the exclusion of food from the structure/function prong of the drug definition was expanded, without discussion, to include cosmetics.¹⁶ However, that bill was not passed by the House of Representatives, and no subsequent legislation retained the cosmetic exclusion. Accordingly, any cosmetic represented to affect the structure or function of the human body is classified as a drug as well as a cosmetic and must meet the statutory requirements for both categories of products.

Finally, Congress also included in the 1938 Act, as it had in the 1906 Act, a third prong of the drug definition to include articles recognized in specified pharmacopeias. However, this was intended to include pharmacopeial articles only when they are in fact represented for disease or structure/function purposes.¹⁷ Accordingly, this prong of the definition may be excluded from further consideration in this chapter.

With these principles and policies established, Congress enacted the FD&C Act in 1938 with the following two pertinent definitions. A drug was defined in Section 201(g) to mean:

... (1) articles recognized in the official United States Pharmacopeia, official Homeopathic Pharmacopeia of the United States, or official National Formulary, or any supplement to any of them; (2) articles intended for use in the diagnosis, cure, mitigation, treatment, or prevention of disease in man or other animals; and (3) articles (other than food) intended to affect the structure or any function of the body of man or other animals ...

A cosmetic was defined in Section 201(i) to mean:

... articles intended to be rubbed, poured, sprinkled, or sprayed on, introduced into, or otherwise applied to the human body or any part thereof for cleansing, beautifying, promoting attractiveness, or altering the appearance ...

Parts of the drug definition not pertinent here have been revised since 1938, but the central core of the definition has not been altered. No part of the cosmetic definition has been changed. Thus, the controlling definitions have remained in place for the entire 76 year history of the FD&C Act.

Implementation of the FD&C ACT

The regulatory consequences of classifying a product as a drug rather than as a cosmetic are substantial. A drug will almost invariably be determined by FDA to be a “new drug” that requires substantial preclinical toxicological testing, clinical testing under an investigational new drug (IND) application, submission of a new drug application (NDA) requesting FDA approval, and ultimately marketing under substantial FDA post-approval requirements, including drug good manufacturing practice (GMP) regulations.¹⁸ New drugs typically require a decade or more for research and development prior to FDA approval and require the investment of hundreds of millions of dollars. In short, it is only the very rare cosmetic product that could justify this level of investment.

It is, therefore, essential that cosmetic products be formulated and labeled in such a way as to avoid the drug definition.

Initial FDA Action Under the FD&C Act

FDA scientists recognized very early that all cosmetics penetrate the skin and thus inherently affect the structure or function of the body:¹⁹

... there are few if any substances which are not absorbed through the intact skin, even though the idea is prevalent that the skin is a relatively effective barrier to its environment.

Nonetheless, the FDA recognized that Congress fully intended a separate category of cosmetic products regardless of their inherent effect on the structure or function of the body, as long as no structure/function or disease claims were made for them.

The FDA sought to establish policy on the distinction between a cosmetic and a drug in three ways. First, the FDA issued formal trade correspondence that set forth advisory opinions on the classification of products. Second, the agency published pamphlets and other educational materials with examples of product classification. Third, it brought court action to contest the legality of cosmetic products with labeling that contained what the agency concluded to be drug claims. From this body of literature and precedent have emerged, over seven decades, a number of well-developed examples:

A suntan product is a cosmetic, but a sunscreen product is a drug. A deodorant is a cosmetic, but an antiperspirant is a drug.

A shampoo is a cosmetic, but an antidandruff shampoo is a drug. A toothpaste is a cosmetic, but an anticaries toothpaste is a drug. A skin exfoliant is a cosmetic, but a skin peel is a drug.

A mouthwash is a cosmetic, but an antigingivitis mouthwash is a drug.

A hair bulking product is a cosmetic, but a hair growth product is a drug. A skin product to hide acne is a cosmetic, but an antiacne product is a drug. An antibacterial deodorant soap is a cosmetic, but an antibacterial anti-infective soap is a drug.

A skin moisturizer is a cosmetic, but a wrinkle remover is a drug.

A lip softener is a cosmetic, but a product for chapped lips is a drug.

This list is illustrative and not exhaustive.

Products that are represented only to change the structure or function of the hair or nails are regarded as cosmetics and not drugs. For example, permanent waves and cuticle removers are cosmetics and not drugs.²⁰ On the other hand, products that are represented to affect the hair or nails systemically are regarded as drugs.

Cosmetic products represented as “hypoallergenic,” and thus with reduced allergic potential, remain classified as cosmetics and not as drugs.²¹ If these products are represented to treat specific reactions or diseases, they would be classified as drugs.

Inclusion of an active ingredient in a cosmetic does not automatically classify it as a drug, unless the active ingredient is so closely identified with therapeutic properties that the mere use of the term would connote a drug claim. For example, use of the term “penicillin” or “AZT” would preclude classification of the product solely as a cosmetic because of their well-recognized therapeutic purposes.²² However, in many instances, ingredients can be used in both cosmetic and drug products. When the FDA banned all topical nonprescription drug products containing hormones, the agency stated that cosmetics could continue to contain hormones without becoming drugs if the chemical name of the specific hormone was included in the ingredient statement and the word “hormone” was not used in the labeling or advertising.²³

In many instances, the context of a word or phrase must be considered before a determination can be made about proper classification of the product as a drug or cosmetic. A product represented as a treatment for disease is a drug, but a product represented as a beauty treatment is a cosmetic. A product represented to kill germs that cause infection is a drug, but a product represented to kill germs that cause odor is a cosmetic.

These examples illustrate the difficulty in drawing a clear and definitive distinction between these two categories of products. Nonetheless, these distinctions have come to be understood by both FDA and industry, and serve the extremely useful purpose of guiding decisions in this area.

Wrinkle Remover Cases of the 1960s

In the early 1960s, the cosmetic industry developed a line of products, broadly characterized as “wrinkle remover” products, containing ingredients intended to smooth, firm, and tighten the skin temporarily and thus to make wrinkles less obvious. In 1964, FDA seized several of these products, alleging that they were drugs under the FD&C Act. The resulting litigation produced three decisions by U.S. District Courts and two decisions by U.S. Courts of Appeals involving three products: Line Away, Sudden Change, and Magic Secret.

The District Court in the Line Away case took the position that, by intending to smooth and tighten the skin, Line Away had as its objective affecting the structure of the skin and thus was a drug.²⁴ The Court of Appeals agreed, citing the “strong therapeutic implications” of the promotional material.²⁵

The District Court in the Sudden Change case concluded that the product was represented merely to alter the appearance of the skin and thus was a cosmetic.²⁶ The U.S. Court of Appeals reversed, and in its opinion was the only court to confront the relationship between the cosmetic definition and the structure/function portion of the drug definition.²⁷

The Court of Appeals first accepted the FDA argument that the claim must be viewed from the standpoint of protecting “the ignorant, the unthinking, and the credulous” consumer. That standard has since been changed by both FDA and the FTC, which now rely on a “reasonable person” for determining the meaning of a claim. Based on that now-rejected standard, the Court of Appeals then stated that whether a product is intended to affect the structure or function of the body must be determined by whether the claim:

... may fairly be said to constitute a representation that the product will affect the structure of the body in some medical—or drug-type fashion, i.e., in some way other than merely “altering the appearance.”

Putting aside the erroneous reliance upon the “ignorant, unthinking, and credulous” standard, the cosmetic industry believes that the Second Circuit interpretation of the relationship between the cosmetic and drug definitions is correct.

The Sudden Change decision was decided by a 2–1 vote of the panel. The dissenting judge did not need to address the relationship of the two definitions, because this judge applied a “reasonable person” standard and determined that the net impression of all of the claims brought them within the “altering the appearance” portion of the cosmetic definition and the product was not intended to affect the structure of the body:

To summarize my position, unless a product is in fact a “drug” as defined in the Food, Drug and Cosmetic Act or a reasonable person would conclude from a reading of the label and enclosure as a whole that it is intended to possess the properties of a drug as so defined, I would not classify it as such merely because one or two phrases, taken out of context, imply possible drug properties. The effect of such a course is to draw a line between permissible and impermissible description of cosmetics that is altogether too delusory and shadowy to permit a workable standard, with the result that most cosmetics must be classified as drugs.

Thus, all three judges in the Sudden Change decision applied basically the same interpretation of the relationship between the cosmetic definition and the structure/function portion of the drug definition. However, the majority went out of its way to state that all of the traditional cosmetic claims (e.g., that a product will soften or moisturize the skin) remain within the cosmetic category. The dissent argued that the two claims cited by the majority as drug claims were indistinguishable from such cosmetic claims as smoothes, firms, tones, and moisturizes the skin.

Finally, the District Court in the Magic Secret case determined that the product was a cosmetic, not a drug, on the basis of the conclusion that the claims were less exaggerated than in the other two cases. The court held that the claim that the product caused an “astringent sensation” would not be regarded by consumers as doing anything other than altering their appearance.²⁸

By this time, it was apparent to both the FDA and the regulated industry that further litigation would be unproductive. Industry sought to modify its claims in order to bring them within the cosmetic boundaries established by the FDA administrative precedent and the judicial decisions. The FDA concluded to provide any further guidance with respect to the distinction between a drug and a cosmetic through the over-the-counter (OTC) Drug Review, which was initiated in the early 1970s.

OTC Drug Review

Under the Drug Amendments of 1962,²⁹ which were enacted following the thalidomide disaster in order to strengthen drug regulation in the United States, FDA was required to review every new drug application (NDA) that had become effective on the basis of an agency safety review between 1938 and 1962 in order to determine whether the drug was effective as well as safe. For prescription drugs, FDA submitted the pre-1962 NDAs for review by the National Academy of Sciences, under the Drug Efficacy Study Implementation (DESI) program. For nonprescription drugs (also called OTC drugs), FDA chose a different approach. Under procedures promulgated in 1972,³⁰ FDA established advisory committees to review all of the pharmacological categories of OTC drugs and to prepare reports on the safety, effectiveness, and labeling for all existing categories of OTC drugs. The advisory committee reports, together with a proposed monograph, were published in the Federal Register for public comment. After reviewing the public comment, FDA published its own conclusions together with a tentative final monograph for further public comment. Following its consideration of the second round of public comments, FDA promulgated a final monograph establishing the conditions for safe and effective use, including required and permitted labeling of the OTC drugs that fall within that drug category. An OTC drug ingredient that was not included in a final monograph could no longer be used as an active ingredient in an OTC drug following the effective date of the final monograph, but could be used as an inactive ingredient or as a cosmetic ingredient.

The OTC Drug Review inherently raised issues relating to the distinction between a cosmetic and a drug. All of the traditional cosmetic drug products—sunscreens, antiperspirants, antidandruff shampoos, anticaries toothpaste, skin protectants, hormone creams, acne products, and so forth—were reviewed under the OTC Drug Review. FDA made clear that only the drug and not the cosmetic aspects of cosmetic drugs were subject to review and evaluation, and ultimately a final monograph, under this program. Thus, in many of the advisory committee meetings and subsequent reports,³¹ as well as in the preambles to the tentative final³² and final³³ monographs, there has been substantial discussion about the dividing line between a drug claim and a cosmetic claim for a cosmetic drug. In several instances, FDA has explicitly stated that a final monograph covered only products making drug claims and did not cover cosmetic claims for the drug products.

The distinction between a cosmetic and a drug became important early in the OTC Drug Review process. On the basis of an advisory committee recommendation, FDA published regulations banning three substances as unsafe for use: hexachlorophene,³⁴ halogenated salicylanilides,³⁵ and zirconium.³⁶ Recognizing that these substances could properly be used in both drugs and cosmetics, FDA published parallel regulations to assure that both types of uses would be banned.

For the most part, the OTC Drug Review has proceeded without major controversy with respect to the classification of cosmetic and drug claims. In general, FDA has followed the traditional cosmetic/drug distinctions described earlier in this chapter. In a few remaining monographs, however, the FDA has proposed to change its policy with respect to important products. It has proposed to reclassify “kills germs that cause odor” from the cosmetic category to drug status.³⁷ It initially proposed to set a limit on cosmetic use of hormone ingredients, above which they would automatically become drugs,³⁸ and then withdrew the proposal on the ground that substantial time had passed since it was proposed and it was no longer a priority.³⁹ Although FDA had previously stated that suntan products are cosmetics,⁴⁰ it proposed to reclassify them as drugs, but then retained them as cosmetics (with a required sunburn warning) in the final regulations.⁴¹ In 2003, FDA proposed to bring under the OTC Drug Review several ingredients that the cosmetic industry regards as appropriate cosmetic ingredients.⁴² FDA has not taken further action on this proposal. Industry, in turn, has asked FDA to classify sunscreen ingredients when used in nonbeach traditional cosmetic formulations as cosmetic ingredients rather than as drugs, in order to encourage the cosmetic industry to include sunscreen ingredients in skin-care products for public health protection wherever feasible, but FDA rejected this approach.⁴³

Warning Letters of the Late 1980s

For a period of 15 years following the conclusion of the wrinkle remover cases, the FDA pursued cosmetic/drug issues largely through the OTC Drug Review and seldom, if ever, through Regulatory or

Warning Letters or direct court action. On the basis of new product technology and the conclusion that the consuming public was becoming increasingly sophisticated about skin-care products and their claims, the cosmetic industry gradually became more aggressive with cell rejuvenation and other anti-aging promotional claims. As a result of research and development in the intervening years, new and more effective products were now on the market.

Two defining events served to initiate a new round of FDA enforcement activities against skin-care claims in the late 1980s. First, in 1986 the well-known South African heart surgeon, Christiaan Barnard, made a tour of the United States on behalf of a cosmetic company to promote its skin-care product, Glycel. Barnard made extravagant claims for Glycel on the television program, *Nightline*, with FDA Commissioner Frank Young participating on the same program. Second, an attorney for a major cosmetic company wrote Dr. Young to protest the claims being made for Glycel. As a result, in 1987 the FDA began to issue regulatory letters not only to the manufacturer of Glycel, but also to other leading members of the industry.⁴⁴ More than 20 regulatory letters were sent in the first wave, and when FDA concluded that the response was unsatisfactory the agency sent another 20. Complex negotiations ensued among the FDA, individual companies, and a consortium of companies. FDA established the agency position on the matter with a letter from the FDA Associate Commissioner for Regulatory Affairs, John Taylor⁴⁵:

We consider a claim that a product will affect the body in some physiological way to be a drug claim, even if the claim is that the effect is only temporary. Such a claim constitutes a representation that the product is intended to affect the structure or function of the body and thus makes the product a drug under 21 U.S.C. 321(g)(1)(C). Therefore, we consider most of the anti-aging and skin physiology claims that you outline in your letter to be drug claims. For example, claims that a product “counteracts”, “retards”, or “controls” aging or the aging process, as well as claims that a product will “rejuvenate”, “repair”, or “renew” the skin, are drug claims because they can be fairly understood as claims that a function of the body, or that the structure of the body, will be affected by the product. For this reason also, all of the examples that you use to allege an effect within the epidermis as the basis for a temporary beneficial effect on wrinkles, lines, or fine lines are unacceptable. A claim such as “molecules absorb” ... and expand, exerting upward pressure to “lift” wrinkles “upward” is a claim for an inner, structural change.

The Associate Commissioner did offer some guidelines for cosmetic claims:

While we agree with your statements that wrinkles will not be reversed or removed by these products ... we would not object to claims that products will temporarily improve the appearance of such outward signs of aging. The label of such products should state that the product is intended to cover up the signs of aging, to improve the appearance by adding color or a luster to skin, or otherwise to affect the appearance through physical means ...

However, we would consider a product that claims to improve or to maintain temporarily the appearance or the feel of the skin to be a cosmetic. For example, a product that claims to moisturize or soften the skin is a cosmetic.

Following the FDA letter, one company brought court action to obtain a declaratory judgment that its product was a cosmetic rather than a drug, but the court ruled that a Regulatory Letter could not be contested in this way, and the issue remained unresolved.⁴⁶ Individual companies eventually worked out their issues with FDA and thus the agency was not required to bring formal court action against even one product.

The Alpha-Hydroxy Acid (AHA) Products of the 1990s

In the early 1990s, the cosmetic industry developed and marketed a line of products containing alpha-hydroxy acids such as glycolic, lactic, and citric acid that occurred in natural food products to cleanse dead cells from the surface of the skin and assist moisturization. The AHAs have been used in consumer products at relatively modest levels, usually at $\leq 10\%$, in contrast with very high levels used in

professional skin peeling products.⁴⁷ It is universally accepted that the AHA products are among the most effective skin-care beauty products that the industry has ever developed. As a result, they became extremely popular with consumers and gained substantial media and regulatory attention.

FDA raised two questions about the AHA products. First, the agency questioned the claims being made. FDA sought to adhere to the guidelines established in the November 1987 letter on the anti-aging and cell rejuvenation products. Second, FDA also questioned the safety of these products, not on the ground that there are known toxicological concerns but rather on the ground that their safety is unproven. However, in contrast with the cell rejuvenation claims of the 1980s, FDA did not launch another wave of Warning Letters. FDA did publish a “Guidance” in January 2005 recommending that cosmetics containing an AHA be labeled with a Sunburn Alert advising users to limit sun exposure.⁴⁸ A company that had obtained FDA approval of NDAs for anti-aging drugs, frustrated by this lack of FDA action, brought a private false advertising case under Section 43(a) of the Lanham Act⁴⁹ against a competitor making aggressive claims for a cosmetic product, but lost in both the District Court⁵⁰ and the Court of Appeals.⁵¹

The Eyelash Enhancer Products in the 2000s

In the early 2000s, Allergan, Inc. discovered that its prescription drug, Lumigan, containing bimatoprost, a prostaglandin, which FDA had approved for the treatment of glaucoma, also produced longer eyelashes. Cosmetic companies soon began to market cosmetic products containing the same or a similar prostaglandin. Some of the marketing materials for the cosmetic products broadly referred to “eyelash growth” whereas others were careful to limit their claims for use as “eyelash enhancers.” FDA took regulatory action against products with eyelash growth claims on the ground that they were drug claims because they were intended to affect the structure or function of the body. But the agency did not take regulatory action against the eyelash enhancer products.

After Allergan obtained FDA approval of an NDA for eyelash growth claims for its product Latisse, the company sued Athena Cosmetics, one of the companies using eyelash enhancer claims for a different but related prostaglandin product. The District Court⁵² and U.S. Court of Appeals for the Federal Circuit⁵³ both held that Athena had consistently made direct or implied eyelash growth claims. Neither court held that the use of a prostaglandin in and of itself made the product a drug.

Use of Foreign Marketing Experience

As mentioned earlier, the cosmetic industry has been forced to stay within the confines of traditional cosmetic claims for skin-care products, which could potentially justify stronger promotion, because the only other alternative is the bottomless pit of the IND/NDA process for drugs. To create a more realistic alternative, FDA has sought to modify its position on OTC drugs.

When the OTC Drug Review was initiated in 1972, FDA announced two policies that were designed to confine the scope of the Review. First, the Review included only those products on the market prior to the final procedural regulations, published in June 1972. This date was later extended to December 1975. Second, the Review included only products marketed in the United States and excluded those marketed abroad. As a result, it was impossible to market in the United States any nonprescription drug that had been sold abroad before the cutoff date or that was developed at any time, anywhere in the world, after the cutoff date.

These two policies were adopted for management, not legal, reasons. The OTC Drug Review was an enormous undertaking, and the FDA concluded that it was essential to establish limitations in order to avoid a perpetual process. Nonetheless, these two policies had a major adverse impact. Some products marketed abroad have important public health benefits. For example, sunscreen products providing protection against both ultraviolet A (UVA) radiation and ultraviolet B (UVB) radiation have been available in Europe for years but cannot be marketed in the United States because of the restrictive FDA policy. FDA has refused to bring these products within the OTC Drug Review. In the interim, U.S. residents are denied important public health protection solely because of this policy.

Recognizing the adverse public health consequence of its policy and in light of a court decision invalidating a parallel policy for food ingredients,⁵⁴ FDA opened up the OTC Drug Review to include new

conditions under the OTC drug monograph system based upon foreign marketing experience.⁵⁵ FDA promulgated a final regulation establishing this policy in 2002, but it is so narrowly circumscribed and has such a low agency priority that it has only very limited utility.

Under this procedure, a number of European sunscreen products have been the subject of petitions to FDA. These petitions have languished in FDA for several years without final agency action. Because of substantial congressional criticism and the threat of legislative action by Congress,⁵⁶ FDA hurriedly released responses to these petitions in 2014. The agency responses only increased public criticism because they ignored the years of European marketing experience and instead imposed strict NDA requirements.

In the interim, additional pressure is being placed on FDA to change its policy in order to achieve international harmonization in the regulation of cosmetics and nonprescription drugs. It is difficult, if not impossible, to reconcile the FDA policy that excludes foreign marketing experience with the requirements of the General Agreement of Tariffs and Trade (GATT).⁵⁷ The Food and Drug Administration Modernization Act of 1997 requires FDA to work toward international harmonization and mutual recognition agreements relating to drugs between the European Union and the United States.⁵⁸ The combination of all of these efforts may well produce a more flexible approach toward FDA approval of nonprescription cosmetic drugs.

If FDA were to recognize foreign marketing experience and engage in international harmonization, the distinction between a cosmetic and a drug in the United States could become less crucial. A number of products that are marketed as cosmetic drugs in the United States are classified solely as cosmetics in Europe. Cosmetic drugs can also be marketed in Europe with less restrictions than apply in the United States. Once a cosmetic drug is on the market in Europe, entry into the United States could become easier on the basis of international harmonization and mutual recognition principles.

Rationale of the Tobacco Initiative

In August 1995, FDA published two notices in the Federal Register relating to the proposed regulation of tobacco.⁵⁹ The first notice set forth the proposed regulation governing cigarettes. The second notice consisted of an analysis supporting the agency's decision on the matter. Normally, regulation of cigarettes would have little or nothing to do with regulation of cosmetics. However, the rationale provided by FDA for asserting its jurisdiction over cigarettes, as well as some of the specific discussion in the Federal Register preambles, is of substantial importance to the cosmetic/drug distinction.

As discussed earlier, the FD&C Act provides that a drug includes articles "intended to affect the structure or any function of the body." In its analysis relating to cigarettes, FDA took the position that the "intent" required under this definition means the "objective" intent of the manufacturer, not the "subjective" intent (i.e., the manufacturer's representation for the product). FDA contended that "objective" intent requires a "reasonable person" test, and that a manufacturer is charged with the reasonable foreseeability—the natural and foreseeable consequences—of its action. Thus, FDA asserted that it has authority under the FD&C Act to classify products as drugs where they inherently result in nontherapeutic but pharmacological effects even though no pharmacological or therapeutic claims are made for the products. The following cosmetic examples were given by FDA: topical hormones and sunscreens. However, FDA analysis stated that courts have distinguished between "remote physical effects" that would not make a product inherently a drug and "significant effects on structure or function" which the agency concluded fall within the drug definition.⁶⁰

In its final regulation published in August 1996,⁶¹ FDA adhered to this position. FDA categorically rejected the contention that the intended use of a product must be derived solely from the manufacturer's subjective intent (i.e., promotional claims for the product). However, FDA did reiterate that the structure/function provision would not extend to products that have a "remote physical effect on the body."⁶²

The U.S. District Court that reviewed this matter upheld the FDA position on "intended use."⁶³ However, on appeal, the U.S. Court of Appeals overturned the District Court and declared the FDA regulations unlawful.⁶⁴ In a divided decision, the majority of the Court of Appeals agreed with the District Court that "no court has ever found that a product is 'intended for use' or 'intended to affect' within the

meaning of the [Act] absent manufacturer claims as to that product's use," but then went on to decide the case on completely different grounds. The majority concluded, as a matter of statutory construction, that the FDA has no jurisdiction over tobacco products under the FD&C Act, and thus it was unnecessary to determine the scope of the "intended use" provision in the structure/function prong of the drug definition. The dissenting judge agreed with the FDA interpretation of intended use. The U.S. Supreme Court upheld the Court of Appeals in a 5-4 divided decision.⁶⁵ The majority did not address the "intended use" issue and the minority agreed with the FDA interpretation.

As a result, we are left with an FDA interpretation, a District Court agreement with that interpretation, two judges on the Court of Appeals who disagreed with the FDA interpretation but determined it was irrelevant, one judge on the Court of Appeals who also agreed with the FDA interpretation, four Supreme Court justices who agreed with the FDA interpretation, and five Supreme Court justices who determined it was irrelevant. In short, the state of the law remains quite uncertain in this area. However, even if the FDA interpretation were upheld, it would still exclude all cosmetics with structure/function effects that are remote or insignificant.

Since the Supreme Court decision, FDA has repudiated the extreme interpretation the agency advanced in the Federal Register notices announcing the tobacco initiative. In October 2002, the FDA Chief Counsel wrote an opinion stating that the "intended use" of a product is determined by the claims made for the product, not by the foreseeable effects of the product.⁶⁶ Based on this opinion, FDA reclassified decorative contact lens as cosmetics rather than as medical devices, because they are presented solely for cosmetic purposes.⁶⁷ Congress then overruled FDA and classified all contact lenses as medical devices because of safety concerns, but explicitly did not change the statutory distinction between a cosmetic and a medical device or drug.⁶⁸

Labeling and Manufacturing Difficulties for Cosmetic Drugs

Compliance with the combined cosmetic and drug provisions of the FD&C Act can be difficult and aggravating. However, FDA regulations have in the past sought to accommodate cosmetic drug labeling requirements,⁶⁹ and the FDA Modernization Act specifically reconciled the two different approaches to ingredient labeling.⁷⁰ To the extent that FDA continues to ignore the labeling complexities of cosmetic drugs—as it did, for example, in promulgating the final regulations for nonprescription sunscreen drugs⁴² and for the new labeling requirements for all nonprescription drugs⁷¹—concerns about the dividing line between a cosmetic and a drug will be greatly aggravated. Although the FDA has declined formally to acknowledge different good manufacturing practice standards for cosmetic drugs,⁷² in practice cosmetic drugs are usually not held to the identical requirements.

Claims for Organic Cosmetics

Under the Organic Foods Production Act of 1990,⁷³ the U.S. Department of Agriculture (USDA) has established detailed standards for organic food certification and labeling.⁷⁴ FDA has no regulations or other policy relating to cosmetics labeled as organic.⁷⁵ USDA takes the position that, if a cosmetic contains agricultural ingredients that meet the USDA organic standards, it is eligible for certification and labeling under the National Organic Program.⁷⁶ Because of a proliferation of organic claims for cosmetics, there have been a number of proffered approaches to regulate these claims. Thus far, no resolution of these approaches has prevailed.

Budgetary Impact on the FDA

The ability of the FDA to monitor and bring regulatory action with respect to claims for cosmetic products must take into account the resources available to the agency for this purpose. During the past several years, the FDA has experienced a flat budget. Because of the inexorable impact of inflation, this has been tantamount to a substantial reduction in available resources. At the same time, the FDA has been pursuing its tobacco initiative and a presidential initiative on food safety. As a result of all of these budgetary factors, the FDA announced in 1998 that it was reducing the staff of the Office of Cosmetics

and Colors by 50% and cutting back or eliminating many cosmetic regulatory programs.⁷⁷ This reduction was so substantial that it propelled the cosmetic industry to request and obtain restoration by Congress of adequate funds to assure that the FDA has a credible cosmetic regulatory program. As a result of a report prepared for the FDA Science Board on the reduction of FDA resources available to regulate food and cosmetics,⁷⁸ the House of Representatives held a bipartisan hearing in early 2008⁷⁹ and agreed to provide a substantial increase in FDA appropriations. Between 2008 and 2013 the annual FDA appropriations have roughly doubled, from \$2 billion to \$4 billion. The appropriations for regulation of cosmetics have increased from \$3.5 million to \$11.7 million.

Potential Future Approaches

For more than 50 years, there has been widespread debate about whether, and how, the current statutory definitions of cosmetic and drug should be changed. Virtually every option has been considered, from making no change at all to modest or even substantial legislative changes.

Advocates of leaving the statute unchanged contend that, in general, there is already sufficient flexibility in the law to permit valid cosmetic claims and that any attempt to change the legislation might well result in a worse situation rather than a better one. Even the November 1987 FDA guidelines provide industry with a great deal of flexibility. Creative marketing has found a way to convey the benefit of innovative new cosmetic products to consumers, as shown by experience with the AHA products. Thus, there is a little to be gained, and potentially a great deal to be lost, by Congress considering changes in the cosmetic provisions of the FD&C Act that have stood the test of 76 years of experience without a single amendment.

Advocates of moderate change contend that all that would be needed is to insert the two words “and cosmetics” in the parenthetical exclusion for food that currently exists in the structure/function prong of the drug definition—the approach taken by the Senate in April 1935¹⁶—with the result that both food and cosmetics would be excluded from this portion of the definition. This would allow cosmetics to make structure/function claims comparable with the structure/function claims available to dietary supplements and conventional food.⁸⁰ It would be necessary to obtain clear legislative history that a structure/function claim is not an implied disease claim, as FDA once contended for food products.¹⁵ However, advocates of this minimalist legislative approach acknowledge that they can offer no assurance that Congress would not re-examine other portions of the cosmetic provisions of the FD&C Act and perhaps make additional changes.

Advocates for a more extensive legislative approach offer a wide variety of potential statutory changes. Some advocate creating an entire new category of cosmetic drugs that would have its own separate regulatory requirements and prohibitions, halfway between those for drugs and those for cosmetics. Others argue for imposing the same premarket safety requirements for cosmetic drugs as for other drugs, but excluding claims from premarket review or approval. Once again, these advocates acknowledge that Congress could, in the process of establishing any such new statutory scheme, also review and change the existing cosmetic provisions of the FD&C Act. For example, President John F. Kennedy proposed to require new cosmetic applications in legislation introduced in 1962,⁸¹ and a bill to require premarket testing for cosmetics was passed by the Senate in 1976.⁸²

In the more than 50 years that this subject has been debated, no new legislation was enacted to address the matter. Over the same period of time, industry has found ways to accommodate the existing FDA requirements and to reconcile advances in technology with current regulatory policy.

In 2010–2013, Representative Schakowsky and others introduced bills to require stricter regulation of cosmetics.⁸³ Critics of the industry endorsed this legislation. Representative Lance introduced a bill in 2012⁸⁴ that was endorsed by the cosmetic industry. The objective of the Lance bill was to establish a uniform national system of regulation for all cosmetics. The House of Representatives Subcommittee on Health of the Committee on Energy and Commerce held a hearing on all of the pending legislation on March 27, 2012.⁸⁵ Discussions about potential legislation between FDA and the cosmetic industry during 2013–2014 were discontinued when no agreement could be reached on specific statutory provisions or language. Whether any legislation will be feasible in the future remains to be seen.

Conclusion

The history set forth in this chapter reflects the inherent uncertainty in attempting to formulate any bright line between a cosmetic and a drug. Even with legislation, whatever new statutory definitions or standards that might be enacted would inevitably raise close questions of judgment that would continue to evolve over time. Accordingly, legislation will not eliminate the uncertainty inherent in the cosmetic/drug distinction and thus is not the only or even the preferred solution to this matter.

FDA has substantial administrative discretion to determine the line between a cosmetic and a drug. By assuring the safety of cosmetic ingredients through the Cosmetic Ingredient Review program,⁸⁶ the cosmetic industry has substantially reduced concern about the safety of marketed cosmetic products. International harmonization activities have already led FDA to explore opening U.S. requirements to include foreign marketing experience, and the FDA Modernization Act requirements with respect to international harmonization and mutual recognition will accelerate this approach. Thus, a reasonable approach to the cosmetic/drug distinction may be found through administrative and international action.

NOTES

1. Corson R. *Fashions in Makeup from Ancient to Modern Times*. 8, 1972.
2. Pliny, *Natural History*, Vols I–X. H. Rackham and W. H. S. Jones eds. 1938–1962.
3. L. Mass 1886, c. 171, April 29, 1886.
4. Hutt PB, Hutt PB II. A history of government regulation of adulteration and misbranding of food. 39 *Food Drug Cosmet L J* 2, 47–53, 1984.
5. H.R. 9154, 55th Cong., 2d Sess., 1898; S. 4144, 55th Cong., 2d Sess., 1898.
6. Anderson OE. Pioneer statute: The Pure Food And Drugs Act of 1906. 13 *J Publ Law* 189–195, 1964.
7. 34 Stat. 768, 1906.
8. 52 Stat. 1040, 1938, 21 U.S.C. 301 et seq.
9. Hutt PB. A historical introduction. 45 *Food Drug Cosmetic L J* 17, 1990.
10. 1917 Report of Bureau of Chemistry 15–16, in Food Law Institute, Federal Food, Drug, and Cosmetic Law Administrative Reports: 1907–1949, 355, 369–370, 1951.
11. S. 1944, 73d Cong., 1st Sess., 1933.
12. 1933 Report of Food and Drug Administration 13, in Food Law Institute, S. 1944, 73d Cong., 1st Sess., 1933 at 787–799.
13. Section 6, 34 Stat. 768, 769, 1906.
14. S. Rep. No. 361, 74th Cong., 1st Sess. 4, 1935.
15. The legislative history of this prong of the drug definition is reviewed exhaustively in *American Health Products Co., Inc. v. Hayes*, 574 F. Supp 1498 (S.D.N.Y. 1983), affirmed on other grounds, *American Health Products Co. v. Hayes*, 744 F.2d 912 (2d Cir. 1984) (per curiam).
16. 79 Cong. Rec. 4845, April 2, 1935.
17. *United States v. An Article of Drug ... Ova II*, 414 F. Supp. 660 (D.N.J. 1975), affirmed without opinion, 535 F.2d 12448 (Cir. 1975).
18. Hutt PB, Merrill RA, Grossman LA. *Food and Drug Law Cases and Materials*, 4th edn. 2014.
19. Calvery HO. Safeguarding foods and drugs in wartime. 32 *Am Sci*, No. 2, at 103, 119, 1944.
20. FDA. *Facts for Consumers—Cosmetics*, Publication No. 26 at 6, 1965; FDA Trade Correspondence No. 245, April 25, 1940.
21. *Almay, Inc. v. Califano*, 569 F.2d 674 (D.C. Cir. 1977).
22. Cf. *United States v. Articles of Food and Drug*, 444 F. Supp. 266, 271 (E.D. Wisc. 1978).
23. 54 Fed. Reg. 40618, 40619–40620, October 2, 1989; 21 C.F.R. 310.530(a).
24. *United States v. An Article ... "Line Away,"* 284 F. Supp. 107 (D. Del. 1968).
25. *United States v. An Article ... "Line Away,"* 415 F.2d 369 (3rd Cir. 1969).
26. *United States v. An Article ... Sudden Change*, 288 F. Supp. 29 (E.D.N.Y. 1968).
27. *United States v. An Article ... Sudden Change*, 409 F.2d 734 (2d Cir. 1969).
28. *United States v. An Article ... "Helene Curtis Magic Secret,"* 331 F. Supp. 912 (D. Md. 1971).
29. 76 Stat. 780, 1962.

30. 37 Fed. Reg. 85, January 5, 1972; 37 Fed. Reg. 9464, May 11, 1972; 21 C.F.R. Part 330.
31. E.g., 48 Fed. Reg. 46694, 46701–46702, October 13, 1983, (vaginal douche products).
32. E.g., 54 Fed. Reg. 13490, 13491, April 3, 1989 (astringent products).
33. E.g., 56 Fed. Reg. 63554, 63555, December 4, 1991, (dandruff products).
34. 37 Fed. Reg. 219, January 7, 1972; 37 Fed. Reg. 20160, September 27, 1972; 21 C.F.R. 250.250.
35. 39 Fed. Reg. 33102, September 13, 1974; 40 Fed. Reg. 50527, October 30, 1975; 21 C.F.R. 700.15.
36. 40 Fed. Reg. 24328, June 5, 1975; 42 Fed. Reg. 41374, August 16, 1977; 21 C.F.R. 700.16.
37. 59 Fed. Reg. 31402, 31440, June 17, 1994; Cf. *United States v. Undetermined Quantities ... “Pets Smellfree” or “Fresh Pet,”* 22 F.3d 235 (10th Cir. 1994).
38. 58 Fed. Reg. 47611, September 9, 1993.
39. 68 Fed. Reg. 19766, 19769, April 22, 2003; 69 Fed. Reg. 68831, November 26, 2004.
40. FDA Trade Correspondence No. 61, February 15, 1940.
41. 58 Fed. Reg. 28194, 28203–28206, May 12, 1993; 64 Fed. Reg. 27666, May 21, 1999; 21 C.F.R. 740.19.
42. 68 Fed. Reg. 75585, December 31, 2003.
43. 59 Fed. Reg. 28194, May 12, 1993; 64 Fed. Reg. 27666, May 21, 1999; 21 C.F.R. 700.35.
44. “‘Anti-aging’ Creams Challenged,” FDA Talk Paper No. T87-24, May 14, 1987.
45. Letter from FDA Associate Commissioner for Regulatory Affairs John M. Taylor, November 19, 1987.
46. *Estee Lauder, Inc. v. FDA*, 727 F. Supp. 1 (D.D.C. 1989).
47. FDA issued a strong public warning about “chemical skin peeling products” in FDA Press Release No. P92-13, May 21, 1992.
48. FDA, Guidance for Industry: Labeling for Topically Applied Cosmetic Products Containing Alpha Hydroxy Acids as Ingredients, January 10, 2005.
49. 15 U.S.C. 1125(a).
50. *Ortho Pharmaceutical Corp. v. Cosprophar, Inc.*, 828 F. Supp. 1114 (S.D.N.Y. 1993).
51. *Ortho Pharmaceutical Corp. v. Cosprophar, Inc.*, 32, F.3d 690 (2d Cir. 1994).
52. *Allergan, Inc. v. Athena Cosmetics, Inc.* (C.D. Calif., July 19, 2013).
53. *Allergan, Inc. v. Athena Cosmetics, Inc.* 738 F.3d 1350 (Fed. Cir. 2013).
54. *Fmali Herb, Inc. v. Heckler*, 715 Fed. 1385 (9th Cir. 1985).
55. 61 Fed. Reg. 51625, October 3, 1996; 64 Fed. Reg. 71062, December 20, 1999; 67 Fed. Reg. 3060 (January 23, 2002); 21 C.F.R. 330.14.
56. S. 2141 & H.R. 4250, 113th Cong., 2d Sess., 2014.
57. 108 Stat. 4809, 1994.
58. 21 U.S.C. 383(c), added by 111 Stat. 2296, 2373, 1997.
59. 60 Fed. Reg. 41314 & 41453, August 11, 1995.
60. 60 Fed. Reg. at 41467–41470.
61. 61 Fed. Reg. 44396, August 28, 1996.
62. 61 Fed. Reg. at 44667.
63. *Coyne Beahm v. FDA*, 966 F. Supp. 1374 (M.D.N.C. 1997).
64. *Brown & Williamson Tobacco Corp. v. FDA*, 153 F.3d 155 (4th Cir. 1998).
65. *Food and Drug Administration v. Brown & Williamson Tobacco Corp.*, 529 U.S. 120, 2000.
66. Letter from Daniel E. Troy, October 17, 2002.
67. 68 Fed. Reg. 16520, April 4, 2003.
68. 21 U.S.C. 360j(n), added by 119 Stat. 2119, 2005.
69. 21 C.F.R. 701.3(d).
70. 21 U.S.C. 352(e)(1)(A)(iii), added by 111 Stat. 2296, 2357, 1997.
71. 62 Fed. Reg. 9024, February 27, 1997; 64 Fed. Reg. 13254, March 17, 1999; 21 C.F.R. 201.66.
72. 43 Fed. Reg. 45014, 45027–45028, September 29, 1978.
73. 104 Stat. 3359, 3935, 1990.
74. 7 C.F.R. Part 205.
75. FDA website for “Organic” Cosmetics.
76. USDA website for National Organic Program: Cosmetics, Body Care Products, and Personal Care Products.
77. Letter from FDA Director of the Center for Food Safety and Applied Nutrition Joseph A. Levitt, March 30, 1998.
78. Hutt PB, The state of science at the food and drug administration. 60 *Administrative L Rev* 431, 2008.

79. "Science and Mission at Risk: FDA's Self-Assessment," Hearing before the Subcommittee on Oversight and Investigations of the Committee on Energy and Commerce, House of Representatives, 110th Cong., 2d Sess., 2008.
80. 62 Fed. Reg. 23624, April 29, 1998; 65 Fed. Reg. 1000, January 6, 2000; 21 C.F.R. 101.93(f).
81. 108 Cong. Rec. 4167, 4170, March 15, 1962.
82. S. Rep. No. 74-1047, 94th Cong., 2d Sess., 1976; 122 Cong. Rec. 24629, July 30, 1976.
83. E.g., H.R. 1385; 113th Cong., 1st Sess., 2013.
84. H.R. 4395, 112th Cong. 2d Sess., 2012.
85. "Examining the Current State of Cosmetics," Hearing before the Subcommittee on Health of the Committee on Energy and Commerce, House of Representatives, 112th Cong., 2d Sess., 2012.
86. "Potential Health Hazards of Cosmetic Products" Hearings before the Subcommittee on Regulation and Business Opportunities of the Committee on Small Business, House of Representatives, 100th Cong., 2d Sess. 89, 1988.

Index

A

- AA, *see* Arachidonic acid
- AAS, *see* Atomic absorption spectroscopy
- ABS, *see* Access and Benefit Sharing
- Access and Benefit Sharing , 386; *see also* Botanical extracts
- ACEI, *see* Angiotensin converting enzyme I
- Acetylpeptide, 131; *see also* Neurotransmitter inhibitor peptides; Signal oligopeptides
- neurotransmitter inhibitors, 153
- Acetyl tetrapeptides, 152; *see also* Enzyme inhibitor peptides
- Acne, 10–11, 393–394; *see also* Bakuchiol; Botanical extracts; Epicatechin-3-Gallate ; Resveratrol vulgaris, 50–51, 102–103, 120
- Acrylic resins, 221; *see also* Hair-care products
- Activator protein 1 , 100, 284
- Active ingredients, 223, 385; *see also* Botanical extracts; Hair-care products
- Acute UV-induced skin damage, 281–282; *see also* Ultraviolet care
- Adaptogen, 107; *see also* *Rhodiola rosea*
- Adenine, 92; *see also* Kinetin
- Advanced Glycation End-Products , 74, 283
- Aeroallergens, 332; *see also* Skin barrier continuum
- Afamelanotide, 371–372; *see also* Vitiligo
- AGA, *see* Androgenetic alopecia
- AGEs, *see* Advanced Glycation End-Products
- Aging, 118
- AHA, *see* α -Hydroxyacids
- AIF, *see* Apoptosis induced factor
- Akt, 33; *see also* Skin injury
- Alkylresorcinol , 71; *see also* Hexylresorcinol
- Aloe vera extract, 351; *see also* Hyperpigmentation treatment
- Alopecia, 23
- α -Hydroxyacids , 83, 238, 391, 435–436; *see also* Botanical extracts; Hydroxyacids; Moisturizers
- Alpha-melanocyte-stimulating hormone , 344, 371, 393; *see also* Botanical extracts; Melasma; Vitiligo
- α -MSH, *see* Alpha-melanocyte-stimulating hormone
- α -Tocopherol, 178, 276, 349; *see also* Antioxidants; Botanical photoprotection; Melasma
- α -Tocopherol transfer protein , 304
- α -TTP, *see* α -Tocopherol transfer protein
- AM, *see* Antioxidant mixture
- Amino acid derivatives, 163, 175
- acute oral toxicity, 172
- basic features, 163, 137
- dissociation constant, 167
- effective delivery into skin, 173
- existence and roles in skin, 167, 170
- for extended applications, 173–175
- harmonized integrity of skin function with, 170, 172–173
- isoelectric point, 167
- optical rotation, 168–169
- reactivity, 170, 171
- solubility in alcohol, 166
- solubility in water, 164–165
- AMP, *see* Antimicrobial peptide
- Amphoteric surfactants, 221; *see also* Hair-care products
- Androgenetic alopecia , 327
- cosmeceuticals, 327, 328
- mechanism of cosmeceuticals, 328
- 5α -reductase inhibitors, 327
- Angiogenesis, 121
- Angiotensin converting enzyme I , 148
- Anionic surfactants, 221; *see also* Hair-care products
- Anthraquinone, 192; *see also* Organic colorant categories
- Anti-aging clinical parameters, 78; *see also* Hexylresorcinol
- Anti-aging topical peptides, 127, 154; *see also* Enzyme inhibitor peptides; Neurotransmitter inhibitor peptides; Signal oligopeptides
- aging skin, 127–128
- colloidal drug carriers, 129
- as cosmeceuticals, 132–135
- efficacy data, 136–143
- glyceromes, 129
- iontophoresis, 131
- microdermabrasion, 131
- niosome carriers, 129
- peptide hormones, 131
- permeation coefficients, 130
- Potts and Guy equation, 129
- properties allowing protein permeation, 129
- topical cosmeceuticals and skin permeability, 128–131
- tripeptide-10-citrulline, 131
- types of, 131, 144
- Antimicrobial peptide , 239, 333
- Antioxidant, 3, 177, 186–187, 286–287; *see also* Bakuchiol; Botanical extracts; Polyphenols; Skin damage prevention; Topical antioxidants
- α -tocopherol, 178
- combinations, 184–185
- constitutive skin antioxidant network, 178–180
- environmental stressor effect on skin, 180–181
- enzymes, 178
- evaluation, 185
- glutathione, 178–179
- green tea polyphenols, 183
- interactive network activation, 179
- melatonin, 184
- MSR system, 179–180
- non-conventional, 186
- oral supplementation of, 181

- Antioxidant (*Continued*)
 photoprotection, 181
 premature skin aging model, 178
 reactive oxygen species, 177–178
 skin's endogenous, 391
 and sunscreens, 185
 thiol, 184
 vitamin C, 182
 vitamin E, 181–182
- Antioxidant mixture, 375; *see also* Vitiligo
- Antioxidant responsive element, 392; *see also* Botanical extracts
- Anti-wrinkle agents, 288; *see also* Skin damage prevention
- AP-1, *see* Activator protein 1
- Apoptosis induced factor, 3
- AR, *see* Alkylresorcinol
- ARA, *see* Arachidonic acid
- Arachidonic acid, 61, 404; *see also* Biomarine actives; Gamma-linolenic acid–containing vegetable oils
- Arbutin, 351; *see also* Hyperpigmentation treatment
- ARE, *see* Antioxidant responsive element
- Argireline, 153; *see also* Neurotransmitter inhibitor peptides
- Arnica montana*, 366
- Ascorbic acid, 349, 391, 392; *see also* Botanical extracts; Melasma
- Astaxanthin, 287, 405; *see also* Biomarine actives
- Ataxia telangiectasia mutated, 147
- ATM, *see* Ataxia telangiectasia mutated
- Atomic absorption spectroscopy, 214
- Atopic dermatitis, 51, 235; *see also* Skin barrier continuum; Epicatechin-3-Gallate; Moisturizers
 etiology of, 332
 SC lipid barrier, 333
- Atopic eczema, 63; *see also* Gamma-linolenic acid–containing vegetable oils; Moisturizers therapy, 244
- ATR-FTIR, *see* Attenuated Total Reflectance—Fourier Transform Infrared Spectroscopy
- Attenuated Total Reflectance—Fourier Transform Infrared Spectroscopy, 337
- Ayurveda panchakarma, 376; *see also* Vitiligo
- Ayurvedic medicine, 376
- Azelaic acid, 348, 394; *see also* Botanical extracts; Melasma
- AZO colorants, 192; *see also* Organic colorant categories
- B**
- Bakuchiol, 1, 15
 anti-acne, 10–11
 antimicrobial, 12–13
 antioxidant profile, 3–6
 comparative collagen stimulatory effects of, 9
 DNA polymerases, 13
 effect on ATP synthesis, 5
 effects on melanin production and cell viability, 11
 erythema reduction, 8
 extracellular matrix proteins 9
 gene expression profile of, 5, 10
 hypoxia inducible factor 1, 14–15
 inflammation, 6–8
 vs. leading antimicrobial ingredients, 13
 matrix metalloprotease inhibitory activity of, 8–9
 preventative and restorative anti-aging, 2
 pro-inflammatory arachidonic acid pathway inhibition, 6
 pro-inflammatory gene modulation by, 7
 protein tyrosine phosphatases, 13
 retinol analog, 2
 skin hydration and barrier homeostasis, 9–10
 skin lightening and even toning, 11
 source, 1
 STAT3, 14
 structure of, 2
 targets, 13
 tumor suppressor p53, 13–14
 volcanic plot of DNA microarray data, 3
- BaP, *see* Benzo[a]pyrene
- BaP diol epoxide, 299
- BAs, *see* Boswellias
- Basal cell carcinomas, 21
- Basic fibroblast growth factor, 150
- BBI, *see* Bowman–Birk protease inhibitor
- BCCs, *see* Basal cell carcinomas
- Beeswax, 237; *see also* Moisturizers
- Benzo[a]pyrene, 298; *see also* Topical antioxidants
- Benzoyl peroxide, 102, 120
- β -Hydroxyacids, 83, 391; *see also* Botanical extracts; Hydroxyacids
- β -sitosterol, 327; *see also* Androgenetic alopecia
- bFGF, *see* Basic fibroblast growth factor
- BHA, *see* β -Hydroxyacids
- BHT, *see* Butylated hydroxytoluene
- Bimodal acrylics, 222; *see also* Hair-care products
- Bioactives, 207
- Biomarine actives, 403
 arachidonic acid, 404
 biomarine extracts, 403–405
 ceramides, 404
 exopolysaccharide, 404
 fucoidan, 406–407
 gene-chip analysis of, 408
 microsporine like amino acids, 405
 omega-3 fish oils, 404
 pseudopterosins, 403
 seaweeds, 405
 shell extracts, 404
 sphingolipids, 404
- Biopeptide; *see also* Signal oligopeptides
 -CL, 144
 -EL, 146–147
- Biotechnology extracts, 386, 388; *see also* Botanical extracts
- Bismuth oxychloride, 198; *see also* Pearlescent pigments
- Block copolymers, 222; *see also* Hair-care products
- Blood thinners, 365
- BO, *see* Borage
- Bodying agents and thickeners, 222; *see also* Hair-care products

- Bombyx mori*, 152
 Borage, 62
 Boswellias, 351; *see also* Hyperpigmentation treatment
 Botanical extract analysis, 411, 424; *see also*
 Hyperpigmentation treatment
 analysis of metabolites, 422–426
 analyte quantification, 423–424
 basic approaches, 411–413
 chromatography, 413
 column chromatography types, 415
 enantiomeric ratios of selected monoterpenes, 418
 fractionation of bioactive natural products, 412
 gas chromatography 413–418
 high-resolution mass spectrometry, 421–422
 ionization sources used with mass spectrometers, 416
 LC-MS analysis of malonyl-ginsenoside, 414
 LC MS/MS spectrum of bis-hexahydroxydiphenolic acid-glucoside, 421
 mass analyzers, 417–421
 MS/MS experiments, 420
 tandem mass spectrometry, 419, 420–421
 Botanical extracts, 269, 385, 395; *see also* Botanical photoprotection; Hyperpigmentation treatment
 acne, 393–394
 aging, 390–391
 anti-cellulite or slimming, 394–395
 antimicrobial applications, 394
 antioxidants, 391–392
 biotechnology extracts, 386, 388
 botanical proteolytic enzymes, 391
 dried plant powders, 386
 extraction process, 387
 fruit acids, 391
 origin of, 385–386
 phenolic compounds in, 392
 phytosterols, 390
 pigmentation, 393
 plant waxes, 390
 properties, 389
 purification, 388
 selective extracts, 387
 skin moisture and barrier functions, 389
 total extracts, 387
 usage and applications, 389
 Botanical proteolytic enzymes, 391; *see also* Botanical extracts
 Botanical photoprotection, 269
 alpha tocopherol, 276
 caffeine, 273
 Camellia sinensis, 269, 273
 controversies, 276–277
 curcumin, 275
 genistein, 275
 honeybush, 275
 light absorbance and proposed modes of action, 270–272
 lycopene, 269, 273
 Polypodium leucotomos, 274
 pomegranate, 275
 pycnogenol, 276
 resveratrol, 274, 275
 Sanguinaria canadensis, 273–274
 Silybin A, 274
 Silybum marianum, 274
 vitamin C, 276
 vitamin E, 276
 Botulinum toxin, 153
 Bovine spongiform encephalopathy, 386; *see also*
 Botanical extracts
 Bowman–Birk protease inhibitor, 352, 393; *see also*
 Botanical extracts
 BP, *see* Benzoyl peroxide
 BPDE, *see* BaP diol epoxide
 Bridging agents, 222; *see also* Hair-care products
 Brittle nails, 261; *see also* Nail disorders
 BSE, *see* Bovine spongiform encephalopathy
 Btx, *see* Botulinum toxin
 Butylated hydroxytoluene, 52, 239
 Bystander effect, 37; *see also* Skin injury
- C**
- CAE, *see* N-Cocoylarginine ethylester
 Caffeine, 19, 23, 273; *see also* Botanical photoprotection
 anti-cellulite, 22
 as antioxidant, 21
 applications of, 19, 23
 in commercial products, 24–25
 facial redness reduction, 21–22
 hair growth, 23
 investigation on use of, 26–28
 against non-melanoma skin cancers, 20–21
 and skin penetration, 19–20
 Calcineurin inhibitors, 371
 Calcitonin-related peptide, 109
 Calcium carbonate, 203; *see also* Face powders
Camellia sinensis, *See* Green tea
 cAMP, *see* Cyclic adenosine monophosphate
 l-Carbamimidoyl-L-proline, 173; *see also* Amino acid derivatives
 Carbon black, 195
 Carotenoids, 287, 392; *see also* Botanical extracts; Skin damage prevention
 Carrier peptides, 131; *see also* Signal oligopeptides
 Catalase, 92, 108, 179, 284; *see also* Antioxidants; Kinetin
 CATC, *see* Cinnamidopropyltrimonium chloride
 Cationic conditioning polymers, 222; *see also* Hair-care products
 Cationic surfactants, 221; *see also* Hair-care products
 CB, *see* Carbon black
 CCD, *see* Charged coupled device
 CDC, *see* Centers for Disease Control
 Cell membrane complex, 223; *see also* Hair-care products
 Cell rejuvenation serum, 150; *see also* Signal oligopeptides
 Cellular tumor antigen p53, *see* Tumor suppressor p53
 Cellulite, 22, 394–395; *see also* Botanical extracts;
 Caffeine
 Centers for Disease Control, 108
 Ceramides, 404; *see also* Biomarine actives
 CGRP, *see* Calcitonin-related peptide

- Charged coupled device , 211
 Checkpoint kinase , 21
 Chemical burns, 36; *see also* Skin injury
 Chibixiao recipe, 321; *see also* Rosacea
 China clay, *see* Kaolin
 Chk, *see* Checkpoint kinase
 Chloasma, *see* Melasma
 Cholesterol, 237; *see also* Moisturizers
 Chromium oxide, 197; *see also* Inorganic pigments
 Chronic UV-induced skin damage, 282–284; *see also* Ultraviolet care
 Chronological skin aging, 390–391; *see also* Botanical extracts
 Ciclopiroxolamine , 362; *see also* Seborrheic dermatitis
 CID, *see* Collision-induced dissociation
 CIE, *see* Commission Internationale de l'Étude Ina
 Cinnamic acid, 351; *see also* Hyperpigmentation treatment
 Cinnamidopropyltrimonium chloride , 228
 CIs, *see* Calcineurin inhibitors
 c-jun N-terminal kinase , 33
 CLP, *see* 1-Carbamimidoyl-L-proline
 CLS, *see* Comprehensive licensing standards
 CMC, *see* Cell membrane complex ; Critical micelle concentration
 cNOS, *see* Constitutive NO synthase
 N-Cocoylarginine ethylester , 174; *see also* Amino acid derivatives
Coffea arabica, 19; *see also* Caffeine
 Coffeeberry, 352; *see also* Hyperpigmentation treatment
 Cohibin, 152
 Collision-activated dissociation ., 420
 Collision-induced dissociation , 420
 Colloidal drug carriers, 129; *see also* Anti-aging topical peptides
 Colloidal oatmeal, 335
 Color; *see also* Decorative cosmetics; Organic colorant categories; Organic pigments; Specialty pigments
 chemistry, 191
 natural dyes, 193
 pigment complexes, 202
 travel effects, 198
 Colorant quality control, 213; *see also* Decorative cosmetics
 bulk density, 214
 dispersion equipment and vehicles, 214
 heavy metals, 214
 particle size, 214
 shade evaluation, 213–214
 standards establishment, 213
 test methods, 213
 Color regulations, 214; *see also* Colorant quality control; Decorative cosmetics
 color additive regulation, 214
 European regulations, 214, 216–217
 Japanese regulations, 215, 217
 permanent listing of color additive lakes, 216
 permitted ingredients, 217
 restricted U. S. colorants, 217
 United States regulations, 214, 215–216
 Commission Internationale de l'Étude Ina , 282
 Comprehensive licensing standards , 217
 Conditioners, 229–230; *see also* Hair-care products
 Conditioning polymers, 222; *see also* Hair-care products
 Constitutive NO synthase , 173
 Constitutive skin antioxidant network, 178–180; *see also* Antioxidants
 Contact dermatitis, 333–334; *see also* Skin barrier continuum
 Copper tripeptide complex , 144; *see also* Signal oligopeptides
 Corneocytes, 331; *see also* Skin barrier continuum
 Corneodesmosomes, 331; *see also* Skin barrier continuum
 Cosmeceutical retinoids, 348; *see also* Melasma
 Cosmeceuticals, 191, 385; *see also* Botanical extracts
 Cosmetic drugs, 429
 historical overview, 429–430
 Cosmetics, 429, 431, 440; *see also* Drug distinction between drug and, 432
 reduced allergic potential of, 432
 statutory definition, 439
 Cosmetic, Toiletry, and Fragrance Association , 192
 Cosurfactant, 222; *see also* Hair-care products
 COX2, *see* Cyclooxygenase-2
 CPD, *see* Cyclobutane pyrimidine dimers
 CPO, *see* Ciclopiroxolamine
 Cracked heel, 242–244; *see also* Moisturizers
 Cream eye shadows, 208–209; *see also* Eye makeup
 Critical micelle concentration , 337
 CRS, *see* Cell rejuvenation serum
Crysanthellum indicum extract, 320; *see also* Rosacea
 CT, *see* L-Carnitine–L-tartrate
 CTFA, *see* Cosmetic, Toiletry, and Fragrance Association
 Curcumin, 31, 42, 44, 275; *see also* Skin injury; Botanical photoprotection
 burn healing, 36
 clinical applications, 38–41
 NF- κ B-dependent signaling pathways blocked by, 35
 property of, 31
 signaling targets in solar injury, 37
Cuscuta reflexa Roxb, 327; *see also* Androgenetic alopecia
 Cyclic adenosine monophosphate , 19
 Cyclobutane pyrimidine dimers , 37
 Cyclooxygenase-2 , 151
 Cytokines, 307
 Cytokinin-like proteins, 131; *see also* Signal oligopeptides
- D**
- DA, *see* Dopamine
 d- α -Tocopherol, 304; *see also* Vitamin E
 D&C, *see* Drug and Cosmetic
 DCs, *see* Dendritic cells
 D6D, *see* Delta-6-desaturase
 DDR, *see* DNA damage response
 Decorative cosmetics, 191; *see also* Color—chemistry; Color regulations; Colorant quality control; Eye makeup; Foundation; Inorganic pigments; Lipsticks; Pearlescent pigments; Powder cosmetics; Specialty pigments
 color additive, 215

- cosmeceuticals, 191
 - film formers, 213
 - makeup technology, 202
 - nail color, 212–213
 - naturals in cosmetics, 212
 - niche areas of color cosmetics, 191
 - skin color strategies, 211
 - Decorin, 147; *see also* Signal oligopeptides
 - Decorinyl, *see* Tripeptide-10 citrulline
 - Defective powerhouse model of premature skin aging, 178; *see also* Antioxidants
 - DEJ, *see* Dermal-epidermal junction
 - Delta-6-desaturase, 61
 - Dendritic cells, 149
 - Department of Health and Human Services, 429
 - Department of Health, Education, and Welfare, 429
 - Dermal-epidermal junction, 2
 - Dermal papilla, 226; *see also* Hair-care products
 - Dermatitis, 332; *see also* Skin barrier continuum
 - Dermatophagoides pteronissinus* extract, 51
 - DESI, *see* Drug Efficacy Study Implementation
 - DGLA, *see* Dihomo-gamma-linolenic acid
 - DHA, *see* Docosahexaenoic acid
 - DHEW, *see* Department of Health, Education, and Welfare
 - Dihomo-gamma-linolenic acid, 61; *see also* Gamma-linolenic acid-containing vegetable oils
 - Dihydrotestosterone, 10, 23, 327; *see also* Androgenetic alopecia
 - Dihydroxyphenylalanine, 349; *see also* Melasma
 - DIOs, *see* Iodothyronine deiodinases
 - DNA damage response, 36
 - DNA polymerases, 13
 - Docosahexaenoic acid, 404; *see also* Biomarine actives
 - Docosapentaenoic acid, 389
 - Domain mosaic model, 241; *see also* Moisturizers
 - DOPA, *see* Dihydroxyphenylalanine
 - Dopamine, 107
 - DPE, *see* *Dermatophagoides pteronissinus* extract
 - Dried plant powders, 386; *see also* Botanical extracts
 - Drug, 430, 431, 440; *see also* Cosmetics
 - cosmetics vs., 432
 - Drug and Cosmetic, 192
 - Drug Efficacy Study Implementation, 434
 - Dry skin, 62; *see also* Gamma-linolenic acid-containing vegetable oils; Moisturizers; Xerosis
 - and chapped skin, 235, 236
 - Dye, 215; *see also* Decorative cosmetics
- E**
- EC, *see* European Commission
 - ECM, *see* Extracellular matrix
 - Eczema, 332; *see also* Skin barrier continuum
 - EFA, *see* Essential fatty acid
 - EGCG, *see* Epicatechin-3-Gallate
 - EGF, *see* Epidermal growth factor
 - Eicosapentaenoic acid, 237, 389; *see also* Moisturizers
 - EL, *see* Ethyl linoleate
 - Elastin, 283
 - Electron spin resonance, 185; *see also* Antioxidants
 - Ellagic acid, 55, 58
 - in dermatology, 56–57
 - hyperpigmentation, 55, 58
 - side effects, 58
 - skin aging, 55
 - Emollient, 235, 207, 222; *see also* Foundation; Hair-care products; Moisturizers
 - EMPs, *see* Extracellular matrix proteins
 - Emulsifier, 222, 237; *see also* Hair-care products; Moisturizers
 - Endothelial NO synthase, 102
 - Endothelin-1, 11, 76, 393; *see also* Botanical extracts
 - Enfleurance, 388; *see also* Botanical extracts
 - eNOs, *see* Endothelial NO synthase
 - Enzyme 5-alpha-reductase, 394; *see also* Botanical extracts
 - Enzyme inhibitor peptides, 144, 151
 - acetyl tetrapeptides, 152
 - rice peptides, 152
 - silk protein, 152–153
 - soybean protein, 151–152
 - EPA, *see* Eicosapentaenoic acid
 - Epicatechin-3-Gallate, 47, 52
 - acne vulgaris, 50–51
 - anti-aging uses, 47
 - atopic dermatitis, 51
 - in cosmetics, 47
 - for erythema, 49
 - hair growth, 47
 - keloids, 50
 - lipid content of Seb-1 sebocytes after, 51
 - oral formulations of, 49
 - pharmacokinetics, 51–52
 - preventative effect of topical, 49
 - psoriasis, 50
 - for skin diseases, 50
 - structure of, 48
 - sunscreen, 47–50
 - wound healing, 50
 - Epidermal growth factor, 298
 - Epidermal hyperplasia, 288
 - Epigallocatechin-3-gallate, 183, 273, 320–321; *see also* Botanical photoprotection; Polyphenols; Rosacea
 - EPO, *see* Evening primrose
 - Ergocalciferol, 288
 - Erythema action spectrum, 281
 - ESR, *see* Electron spin resonance
 - Essential fatty acid, 62, 236, 389; *see also* Gamma-linolenic acid-containing vegetable oils; Moisturizers
 - ET-1, *see* Endothelin-1
 - Ethyl linoleate, 77
 - EU, *see* European Union
 - European Commission, 214
 - European Union, 195, 290
 - Evening primrose, 62
 - Extender, 215; *see also* Decorative cosmetics
 - Extracellular matrix, 2, 9
 - Extracellular matrix proteins, 128
 - Eyeliners, 209; *see also* Eye makeup

Eye makeup, 207; *see also* Decorative cosmetics; Mascara
 cream eye shadows, 208–209
 pencils, 209–210

F

Face powders, 202; *see also* Powder cosmetics
 calcium carbonate, 203
 colorants, 204
 ingredients, 203
 kaolin, 203
 loose, 202
 magnesium carbonate, 203
 metallic soap, 204
 mica, 204
 perfumes, 204
 polymers, 204
 preservatives, 205
 pressed, 202–203
 sericite, 204
 starch, 204
 talc, 203

Facial hyperpigmentation, 100, 121; *see also* Niacinamide;
 Resveratrol

Facial redness, 21; *see also* Caffeine

FADS, *see* Fatty acid desaturase

Fats, 236; *see also* Moisturizers

Fatty acid desaturase, 64; *see also* Gamma-linolenic
 acid-containing vegetable oils

FDA, *see* U.S. Food and Drug Administration

Federal Security Agency, 429

Fenton reaction, 284

Ferric ammonium ferrocyanide, *see* Iron—blue

Ferric ferrocyanide, 197

Ferulic acid, 308; *see also* Topical antioxidants

Feverfew, 316; *see also* Rosacea

Fibrillin-1, 283

Filaggrin, 119; *see also* Niacinamide

Film formers, 213; *see also* Decorative cosmetics

Flaking, 336; *see also* Skin barrier continuum

Flavonoids, 352; *see also* Hyperpigmentation treatment

Flynn model, 145; *see also* Signal oligopeptides

Foaming agents, 223; *see also* Hair-care products

Food and Drug Administration, 72, 214, 429
 budgetary impact on, 438–439
 policy effects, 436–437

Food, Drug, and Cosmetic Act, 192, 385, 429; *see also*
 Botanical extracts
 alpha-hydroxy acid, 435–436
 on contact lens, 438
 eyelash enhancers, 436
 FDA policy effects, 436–437
 FDA warning letters, 434–435
 implementation of, 431
 international cosmetics regulation, 437
 labeling requirements, 438
 organic food certification, 438
 tobacco regulation, 437–438
 wrinkle remover case study, 433

Foot xerosis, 242–244; *see also* Moisturizers

Foundation, 206; *see also* Decorative cosmetics

anhydrous, 206–207
 bioactives, 207
 emulsified, 206
 formulation guidelines, 206

Fragrances, 223; *see also* Hair-care products

Franz model, 145; *see also* Signal oligopeptides

Fruit acids, 391; *see also* Botanical extracts

FSA, *see* Federal Security Agency

Fucoidan, 406–407; *see also* Biomarine actives

Furan, 92; *see also* Kinetin

G

GAGs, *see* Glycosaminoglycans

Gamma-linolenic acid, 61, 237, 238; *see also* Gamma-
 linolenic acid-containing vegetable oils;
 Moisturizers
 cutaneous significance, 61
 metabolism of, 62
 sources of, 65

Gamma-linolenic acid-containing vegetable oils, 61, 67;
see also Gamma-linolenic acid
 animal studies, 61
 atopic eczema, 62–64
 clinical evaluation, 61
 dry or sensitive skin, 61–62
 inflammatory reactions, 66
 mechanism of action, 65–67
 and skin health, 61

GAPDH, *see* Glyceraldehyde-3-phosphate dehydrogenase

GATT, *see* General Agreement of Tariffs and Trade

G-CSF, *see* Granulocyte-macrophage colony stimulating
 growth factor

Gelatinase A, 144; *see also* Signal oligopeptides

General Agreement of Tariffs and Trade, 437

Genistein, 183, 275; *see also* Botanical photoprotection;
 Polyphenols

GHK-Cu, *see* Copper tripeptide complex

GHK-Mn, *see* Manganese tripeptide complex

Ginkgo biloba, 377; *see also* Vitiligo

GLA, *see* Gamma-linolenic acid

Glutathione, 76, 108, 178–179; *see also* Antioxidants
 Glutathione–methionine sulfoxide reductase system,
 179–180; *see also* Antioxidants

Glutathione peroxidase, 108, 301

Glycation, 74, 118; *see also* Hexylresorcinol

Glyceraldehyde-3-phosphate dehydrogenase, 108

Glyceromes, 129; *see also* Anti-aging topical peptides

Glycolic acid, 84; *see also* Hydroxyacids
 peels, 86

Glycosaminoglycans, 99, 118, 144, 238; *see also*
 Moisturizers; Resveratrol

GMP, *see* Good manufacturing practice

Golden serpent fern, *see* *Polypodium leucotomos*

Good manufacturing practice, 431

GPx, *see* Glutathione peroxidase

Graft copolymers, 222; *see also* Hair-care products

Granulocyte-macrophage colony stimulating growth
 factor, 150

Grape seed extract, 350; *see also* Hyperpigmentation
 treatment

- Green tea, 47, 183, 269; *see also* Hyperpigmentation treatment; Epicatechin-3-Gallate ; Botanical photoprotection; Polyphenols
 in commercial products, 48
 extract, 352
 polyphenols, 183
- Growth factors, 150; *see also* Signal oligopeptides
- GSH, *see* Glutathione
- ## H
- HaCaT, *see* Human keratinocytes
- Hair; *see also* Hair-care products
 curvature method, 227
 fiber and cuticle sublamellar structure, 224
 fixatives, 230–231
 fragility, 227
 shaft, 223, 225
 sprays, 231
 structure and function, 223
- Hair-care products, 221, 232
 advances in, 232
 African hair, 227, 228
 Asian hair, 227, 228
 bonds within hair cellular structure, 226
 Caucasian hair, 227, 228, 230
 conditioner deposition, 229
 conditioners, 229–230
 cross section, 228
 cuticle, 224
 dermal papilla, 226
 fixatives, 230–231
 medulla, 223
 natural products, 231
 racial characteristics of, 227
 shampoos, 227–229
 terms used, 221–223
- Hair cosmeceuticals, *see* Hair-care products
- Hair cosmetics, *see* Hair-care products
- HDL, *see* High density lipoproteins
- HDPE, *see* High density polyethylene
- Heat shock proteins , 32, 150–151; *see also* Signal oligopeptides; Skin injury
 HSP70, 131, 149
- Hepatocyte growth factor , 150
- 15-HETrE, *see* 15-Hydroxyeicosatrienoic acid
- Hexapeptide, 147; *see also* Signal oligopeptides
- Hexylresorcinol , 71–72, 79
 anti-aging, 73, 78
 antimicrobial, 72
 antioxidant, 73–74
 antitumor, 72–73
 formulation, 78–79
 glycation, 74
 human clinical, 76–78
 inflammation, 74
 melanin and melanogenesis, 74
 melanogenesis pathway in melanocytes inhibited by, 76
 pigmentation, 74–75
 skin lightening, 75–76, 77
 structure of, 72
- HGF, *see* Hepatocyte growth factor
- hGH, *see* Human growth hormone
- HHS, *see* Department of Health and Human Services
- HIF-1, *see* Hypoxia inducible factor 1
- High density lipoproteins , 118
- High density polyethylene , 208
- HIV, *see* Human immunodeficiency virus
- HLB, *see* Hydrophilic-lipophilic balance
- HMPs, *see* Hydrophobically-modified polymers
- 13-HODE, *see* 13-Hydroxy-9,11-octadecadienoic acid
- Honeybush, 275; *see also* Botanical photoprotection
- HPCH, *see* Hydroxyl-propyl Chitosan
- HPGD, *see* Hydroxy prostaglandin dehydrogenase
- HPLC- MS analysis, 419
- HQ, *see* Hydroquinone
- HR, *see* Hexylresorcinol
- HS, *see* Hyaluronan synthases
- Hsp, *see* Heat shock proteins
- Human growth hormone , 131
- Human immunodeficiency virus , 357
- Human keratinocytes , 121; *see also* Niacinamide
- Humectants, 238; *see also* Moisturizers
- Hyaluronan synthases , 152
- Hyaluronic acid, 238; *see also* Moisturizers
- Hydrophilicity, 221; *see also* Hair-care products
- Hydrophilic-lipophilic balance , 207
- Hydrophobically-modified polymers , 337
- Hydroquinone , 345; *see also* Melasma
- 13-Hydroxy-9,11-octadecadienoic acid , 61
- Hydroxyacids, 83
 acne and pseudofolliculitis, 86–87
 activities of, 84–85
 boosting skin physiology, 87
 classification, 84
 on corneocyte cohesion and stratum corneum functions, 85–86
 hypopigmenting effect, 86
 peeling and caustic effects, 86
 safety, 87–88
 SLS-induced skin irritation, 86
 structure and source of, 83–84
- 8-Hydroxydeoxyguanosine , 298; *see also* Topical antioxidants
- 15-Hydroxyeicosatrienoic acid , 66
- 2-Hydroxyethanoic acid, *see* Glycolic acid
- Hydroxyl-propyl Chitosan , 265
- 2-Hydroxypropanoic acid, *see* Lactic acid
- 15-hydroxy Prostaglandin dehydrogenase , 7
- Hydroxy prostaglandin dehydrogenase , 7
- Hygiene hypothesis, 332
- Hyperpigmentation, 343; *see also* Hyperpigmentation treatment; Melasma
 cosmeceutical treatments of, 346–347
- Hyperpigmentation treatment, 350; *see also* Botanical extracts; Hyperpigmentation; Melasma
 aloe vera extract, 351
 arbutin, 351
 boswellia, 351
 cinnamic acid, 351
 coffeeberry, 352

Hyperpigmentation treatment (*Continued*)

- flavonoids, 352
 - grape seed extract, 350
 - green tea extract, 352
 - licorice extract, 350–351
 - marine algae extract, 351
 - mulberry extract, 353
 - N-acetyl glucosamine, 352
 - orchid extract, 350
 - pycnogenol, 352
 - soy, 351–352
- Hypertrophic scar formation, 36; *see also* Skin injury
- Hyponychium, 261; *see also* Nail
- Hypoxia inducible factor 1, 14–15

I

- ICAM-1, *see* Intercellular adhesion molecule-1
- Ichthyosis, 242; *see also* Moisturizers
- ICP, *see* Inductive coupled plasma
- Idebenone, 184; *see also* Antioxidants
- IFN α , *see* Interferon α
- IFN- γ , *see* Interferon gamma
- IL-6, *see* interleukin-6
- IND, *see* Investigational new drug
- Indigoid, 193; *see also* Organic colorant categories
- Individual Typology Angle, 7
- Inducible NO synthase, 8, 173
- Inductive coupled plasma, 214
- Inflammation, 74, 119; *see also* Gamma-linolenic acid–containing vegetable oils; Hexylresorcinol; Niacinamide
- dermatoses, 120
 - overreactions, 66
- Inorganic pearls, 198; *see also* Pearlescent pigments
- Inorganic pigments, 193, 194; *see also* Decorative cosmetics; TiO₂ and ZnO
- chromium oxide, 197
 - iron blue, 197
 - iron oxides, 197
 - manganese violet, 197
 - in sunscreens, 195
 - titanium dioxide, 194
 - ultramarines, 197
 - zinc oxide, 194–195
- iNOS, *see* Inducible NO synthase
- Intense pulsed light, 38
- Intercellular adhesion molecule-1, 32, 118
- Interferon gamma, 374
- Interferon α , 129, 149–150; *see also* Signal oligopeptides
- Interleukin, 307
- IL-1 α , 22
 - IL-1 β , 32, 118
 - IL-2, 374
 - IL-1, 298
- Interleukin-6, 14
- Internal wool lipids, 232
- Investigational new drug, 431
- Iodothyronine deiodinases, 301
- Ion-chelators, 288; *see also* Skin damage prevention
- Iontophoresis, 131; *see also* Anti-aging topical peptides

IPL, *see* Intense pulsed light

- Iron, 186; *see also* Antioxidants; Inorganic pigments
- blue, 197
 - oxides, 197
- Island pedicle flap model, 124; *see also* Niacinamide
- ITA, *see* Individual Typology Angle
- IWL, *see* Internal wool lipids

J

- Japan standards of cosmetic ingredients, 217
- JNK, *see* c-jun N-terminal kinase
- JSCI, *see* Japan standards of cosmetic ingredients

K

- Kaolin, 203; *see also* Face powders
- kB site, 33; *see also* Skin injury
- Keloids, 50; *see also* Epicatechin-3-Gallate
- Keratin, 151, 262; *see also* Signal oligopeptides
- Keratinocytes, 75, 108
- Kinetin, 91, 94, 148–149; *see also* Signal oligopeptides
- biology, 91–93
 - clinical studies, 93–94
 - cytological manifestation effects, 93
 - mechanism of, 93
 - structure of, 92
 - treatment effects, 92
- Kojic acid, 348; *see also* Melasma

L

- LA, *see* Linoleic acid
- Lactic acid, 84; *see also* Decorative cosmetics; Hydroxyacids
- Lake, 192, 215; *see also* Organic pigments
- Lanolin, 237; *see also* Moisturizers
- Laser-induced injury, 36; *see also* Skin injury
- Lavender essential oil, 358; *see also* Seborrheic dermatitis
- L-Carnitine–L-tartrate, 328; *see also* Androgenetic alopecia
- L-Dihydroxyphenylalanine, 393; *see also* Botanical extracts
- LDL, *see* Low density lipoproteins
- L-DOPA, *see* L-Dihydroxyphenylalanine
- LEO, *see* Lavender essential oil
- L-ergothioneine, 184; *see also* Antioxidants
- Leukotriene B₄, 6
- LHA, *see* Lipohydroxyacid
- Lichoalchalcone A, 320; *see also* Rosacea
- Licorice extract, 320, 350–351; *see also* Hyperpigmentation treatment; Rosacea
- Light diffusing pigments, 199; *see also* Specialty pigments
- Lignin peroxidase, 350; *see also* Melasma
- Linoleic acid, 61, 77, 237; *see also* Gamma-linolenic acid–containing vegetable oils; Moisturizers
- LIP, *see* Lignin peroxidase
- Lipid peroxide, 285–286; *see also* Ultraviolet care
- Lipids, 236; *see also* Moisturizers

Lipohydroxyacid , 85, 362; *see also* Hydroxyacids;
Seborrheic dermatitis

Lipolysis, 22

Lipophilic, 223; *see also* Hair-care products

Liposterolic extract of *Serenoa repens* , 327; *see also*
Androgenetic alopecia

Lipsticks, 210; *see also* Decorative cosmetics
classical, 210–211
volatile, 211

Long chain fatty alcohols, 222; *see also* Hair-care
products

Low density lipoproteins , 118

LSEsr, *see* Liposterolic extract of *Serenoa repens*

LTB4, *see* Leukotirene B4

Lumican, 131

Lycopene, 269, 273; *see also* Botanical photoprotection

M

MAAs, *see* Microsporine like amino acids

Magnesium carbonate, 203; *see also* Face powders

Magnesium stearate, 204

Maillard reaction, *see* Glycation

Major histocompatibility complex II , 376

Makeup technology, 202; *see also* Decorative cosmetics

Malassezia, 357; *see also* Seborrheic dermatitis

Malic acid, 84; *see also* Hydroxyacids

Malonyldialdehydes , 304

Mandelic acid, 84; *see also* Hydroxyacids

Manganese tripeptide complex , 144; *see also* Signal
oligopeptides

Manganese violet, 197; *see also* Inorganic pigments

MAPK, *see* Mitogen-activated protein kinases

Marine algae extract, 351; *see also* Hyperpigmentation
treatment

Marine-based therapies, 403; *see also* Biomarine actives

Mascara, 207; *see also* Eye makeup
anhydrous, 208
componentry, 208
formulation guidelines, 208
oil-in-water emulsions, 207–208
solvent based, 207
water-in-oil, 207

Mask of pregnancy, *see* Melasma

Matrikines, 131; *see also* Signal oligopeptides

Matrix metalloprotease , 8–9, 282

MC1R, *see* Melanocortin-1 receptor

MCC, *see* Minimum cidal concentration

MDAs, *see* Malonyldialdehydes

MED, *see* Minimal erythema dosage

Melagenina, 377; *see also* Vitiligo

Melanin, 149; *see also* Signal oligopeptides

Melanocortin-1 receptor , 371; *see also* Vitiligo

Melanocytes, 75

Melanogenesis, 75

Melanosomes, 393; *see also* Botanical extracts

Melasma, 343; *see also* Botanical extract analysis;
Hyperpigmentation treatment;
Hyperpigmentation
ascorbic acid, 349
azelaic acid, 348
clinical presentation, 343
cosmeceutical options for treatment, 345
differential diagnosis, 345
histopathologic findings, 344
hydroquinone, 345
kojic acid, 348
lignin peroxidase, 350
mequinol, 345
NCAP, 348
niacinamide, 349–350
retinoids, 348–349
risk factors, 344
Vitamin E, 349

Melasma Quality of Life Scale , 343; *see also* Melasma

MELASQOL, *see* Melasma Quality of Life Scale

Melatonin, 149, 184; *see also* Antioxidants; Signal
oligopeptides

MEO, *see* *Monarda fistulosa* essential oil

Mequinol, 345; *see also* Melasma

Meroterpenes, 1; *see also* Bakuchiol

Meroterpenoid, 1; *see also* Bakuchiol

Metallic soap, 204; *see also* Face powders

Metharmon-F , 377; *see also* Vitiligo

Methionine-R-sulfoxide reductase B , 179; *see also*
Antioxidants

Methionine-S-sulfoxide reductase A , 179; *see also*
Antioxidants

Methylsulfonilmethane , 321; *see also* Rosacea

MF, *see* Metharmon-F

MHC-II, *see* Major histocompatibility complex II

MHW, *see* Ministry of Health and Welfare

Mica, 204; *see also* Face powders

Microdermabrasion, 131; *see also* Anti-aging topical
peptides

Microfine pigments, 199; *see also* Specialty pigments

Microsporine like amino acids , 405; *see also* Biomarine
actives

MICs, *see* Minimum inhibitory concentrations

MIF, *see* Migration inhibitory factor

Migration inhibitory factor , 51

Minimal erythema dosage , 49, 281, 298, 301, 304

Minimum cidal concentration , 102

Minimum inhibitory concentrations , 12

Ministry of Health and Welfare , 215

Mitochondrial DNA , 178; *see also* Antioxidants

Mitogen-activated protein kinases , 33, 127

MMP, *see* Matrix metalloprotease

Moisturizers, 235, 250
application of, 240
atopic eczema therapy, 244
composition of, 236
domain mosaic model, 241
dry and chapped skin, 235, 236
eczema relapse, 245
effect on dry skin conditions, 244
factors in lipid composition of skin, 241
fats, oils, and emulsifiers, 236–237
foot xerosis and cracked heel, 242–244
humectants, 238–239
in hyperkeratosis, 242
ichthyosis, 242

Moisturizers (*Continued*)

- oil effect on skin, 237–238
 - in paediatric skin care, 245–246
 - preservatives and antioxidants, 239–240
 - restoring skin barrier defects, 241–242
 - and skin barrier function, 240
 - skin identical lipids, 242
 - substances to test skin barrier function, 240
 - to treat children, 247–249
 - xerosis treatment, 243
- Monarda fistulosa* essential oil , 358; *see also* Seborrheic dermatitis
- Mousses, 231; *see also* Hair-care products
- MPO, *see* Myeloperoxidase
- MSM, *see* Methylsulfoniomethane
- MSRA, *see* Methionine-S-sulfoxide reductase A
- MSRB, *see* Methionine-R-sulfoxide reductase B
- MSR system, *see* Glutathione–methionine sulfoxide reductase system
- mtDNA, *see* Mitochondrial DNA
- Mulberry extract, 353; *see also* Hyperpigmentation treatment
- Myeloperoxidase , 269; *see also* Botanical photoprotection

N

- N6-Furfuryladenine, *see* Kinetin
- N-Acetyl-4-S-Cysteaminylphenol , 348; *see also* Melasma
- N-acetyl-5-methoxytryptamine, *see* Melatonin
- N-acetyl glucosamine , 352; *see also* Hyperpigmentation treatment
- NAD, *see* Nicotinamide adenine dinucleotide
- NADP, *see* Nicotinamide adenine dinucleotide phosphate
- NAD H:quinone oxidoreductase 1 , 6
- NAG, *see* N-acetyl glucosamine
- Nail, 261, 262; *see also* Decorative cosmetics; Nail disorders; Nail treatments
- color, 212–213
- Nail disorders, 261; *see also* Nail treatments; Nail brittle nails, 261
- onycholysis, 262
 - onychoschezia, 261
- Nail treatments, 262, 266; *see also* Nail disorders; Nail
- biotin, 262
 - calcium, 265
 - cosmeceutical therapies, 263–264
 - genadur nail laquer, 265
 - iron, 265
 - pyridoxine and ascorbic acid, 265
 - selenium, 266
 - silica, 266
 - sulfur-containing proteins, 265
 - vitamin E, 265
 - zinc, 265
- Narrow-band UVB , 371; *see also* Vitiligo
- Natural dyes, 193; *see also* Color—chemistry
- Natural moisturizing factor , 119, 167, 331
- Natural polymers, 222; *see also* Hair-care products
- NBUVB, *see* Narrow-band UVB
- NCAP, *see* N-Acetyl-4-S-Cysteaminylphenol
- NDA, *see* New drug application
- NEP, *see* Neprilysin
- Neprilysin , 405; *see also* Biomarine actives
- Neurotransmitter inhibitor peptides, 153
- acetyl peptide, 153
 - pentapeptides, 153–154
 - tripeptide-3, 154
- Neurotransmitters, 19
- New drug application , 431
- NF- κ B, *see* Nuclear factor- κ B
- NHEK, *see* Normal human epidermal keratinocytes
- Niacin, 117, 349; *see also* Niacinamide
- Niacinamide, 117, 124, 316, 349–350; *see also* Melasma; Rosacea
- acne, 120–121
 - commercial products, 122–123
 - epidermal barrier function repair, 119–120
 - inflammatory dermatoses, 120
 - island pedicle flap model, 124
 - medical applications, 118
 - pharmacology, 117
 - photoaging treatment, 118–119
 - reduction in hyperpigmentation, 121
 - in skin diseases, 117–118
 - wound healing, 121, 124
- Nicotinamide, *see* Niacinamide
- Nicotinamide adenine dinucleotide , 117; *see also* Niacinamide
- Nicotinamide adenine dinucleotide phosphate , 117; *see also* Niacinamide
- Niosome carriers, 129; *see also* Anti-aging topical peptides
- Nitric oxide , 8, 99
- NMF, *see* Natural moisturizing factor
- NMSCs, *see* Non-melanoma skin cancers
- NO, *see* Nitric oxide
- Non-azo soluble dyes, 192; *see also* Organic pigments
- Nonionic surfactants, 222; *see also* Hair-care products
- Non-melanoma skin cancers , 23
- Nonprescription drugs, 434; *see also* Over-the-counter
- Nonsteroidal anti-inflammatory drugs , 373, 403; *see also* Biomarine actives; Vitiligo
- Normal human epidermal keratinocytes , 100; *see also* Resveratrol
- NPC, *see* Nutritional Protection of Cancer
- NQO1, *see* NAD H:quinone oxidoreductase 1
- NSAIDs, *see* Nonsteroidal anti-inflammatory drugs
- Nuclear factor-erythroid-2-related factor-2 , 55, 392; *see also* Botanical extracts
- Nuclear factor- κ B , 32, 284, 307
- Nutritional Protection of Cancer , 301

O

- ODC, *see* Ornithine decarboxylase
- 8-OHdG, *see* 8-Hydroxydeoxyguanosine
- Oil, 236; *see also* Moisturizers
- Oil-in-water , 236
- Oily skin, 357; *see also* Seborrheic dermatitis
- agents studied for, 358, 362
 - differential diagnosis, 357
 - risk factors, 357

- Oligomeric proanthocyanidins , 109
 Omega-3 fatty acids, 236; *see also* Moisturizers
 Omega-6, 236; *see also* Moisturizers
 OMM, *see* Oral mucosal melanoma
 ONC, *see* Optic nerve crush
 Onycholysis, 262; *see also* Nail disorders
 Onychoschezia, 261; *see also* Nail disorders
 OPCs, *see* Oligomeric proanthocyanidins
 Optic nerve crush , 3
 ORAC, *see* Oxygen radical absorbance capacity
 Oral mucosal melanoma , 73
 Orchid extract, 350; *see also* Hyperpigmentation treatment
 Organic colorant categories, 192; *see also*
 Color—chemistry
 anthraquinone, 192
 AZO colorants, 192
 indigoid, 193
 quinoline, 193
 triarylmethane, 192
 xanthenes, 192
 Organic Foods Production Act, 438
 Organic pearls, 198; *see also* Pearlescent pigments
 Organic pigments, 191; *see also* Color—chemistry
 lake, 192
 stability of, 193
 toners, 192
 true pigment, 192
 types of, 191
 Ornithine decarboxylase , 114, 269; *see also* Botanical
 photoprotection
 OTC, *see* Over-the-counter
 Over-the-counter , 433
 drug review, 434, 436
 O/W, *see* Oil-in-water
 Oxidative processes, 118
 Oxygen radical absorbance capacity , 185; *see also*
 Antioxidants
- P**
- p53, *see* Tumor suppressor p53
 PACs, *see* Polycyclic aromatic hydrocarbons
 Pal-KT, 146; *see also* Signal oligopeptides
 Pal-KTTKS, 145–146; *see also* Signal oligopeptides
 Palmitoyl tetrapeptide-7, 147–148; *see also* Signal
 oligopeptides
 PARP, *see* Poly ADP ribose polymerase
 PBMC, *see* Peripheral blood mononuclear cells
 PCA, *see* Pyrrolidone carboxylic acid
 PCNA, *see* Proliferating cell nuclear antigen
 PCS, *see* *Psoralea corylifolia* seed
 PDE, *see* Phosphodiesterase
 PDTC, *see* Pyrrolidine dithiocarbamate
 PE, *see* Polyethylene
 Pearl effect, 198
 Pearlescent pigments, 179; *see also* Decorative cosmetics
 bismuth oxychloride, 198
 inorganic pearls, 198
 organic pearls, 198
 TiO₂ coated mica, 198
 Pellagra, 117; *see also* Niacinamide
 Pencils, 209–210; *see also* Eye makeup
 Penetration and drop tests, 205; *see also* Powder cosmetics
 Pentapeptides, 153–154; *see also* Neurotransmitter
 inhibitor peptides
 PEP-1, 151; *see also* Signal oligopeptides
 PEP-rpS3, 151; *see also* Signal oligopeptides
 Peptide hormones, 131; *see also* Anti-aging topical
 peptides
 Peripheral blood mononuclear cells , 375
 Permeation coefficient, 128; *see also* Anti-aging topical
 peptides
 Peroxisome proliferation-activated receptors , 144, 237
 PFA, *see* Protection factor in UVA
 PGDF, *see* Platelet derived growth factor
 15-PGDH, *see* 15-hydroxy Prostaglandin dehydrogenase
 PH adjusters, 223; *see also* Hair-care products
 PhK, *see* Phosphorylase kinase
 Phosphodiesterase , 19, 20
 Phospholipase A2 , 6, 7
 Phospholipase A-2-activating protein , 7
 Phosphoprotein p53, *see* Tumor suppressor p53
 Phosphorylase kinase , 31, 34; *see also* Curcumin; Skin
 injury
 Photoactivation prevention, 291; *see also* Sunscreen
 Photoaging, 11, 128; *see also* Bakuchiol
 Photodamage, 393; *see also* Botanical extracts
 Phytoalexins, 394; *see also* Botanical extracts
 Phytosterols, 390; *see also* Botanical extracts
 Pidolic acid, *see* Pyrrolidone carboxylic acid
 Pigment, 215; *see also* Decorative cosmetics; Organic
 pigments; Specialty pigments
 treated, 199
 true, 192
 Pigmented reconstructed epidermis , 349
 Piperine, 376; *see also* Vitiligo
 PL, *see* *Polypodium leucotomos*
 PLA2, *see* Phospholipase A2
 PLAA, *see* Phospholipase A-2-activating protein
 Plant waxes, 390; *see also* Botanical extracts
 Platelet derived growth factor , 150
 PMMA, *see* Polymethyl methacrylate
 PNF, *see* Proximal nail fold
 Poly ADP ribose polymerase , 3
 Polycyclic aromatic hydrocarbons , 298
 Polyethylene , 204
 Polymers, 204, 222; *see also* Face powders; Hair-care
 products
 Polymethyl methacrylate, 199
 Polyphenols, 182, 183–184; *see also* Antioxidants
 in coffee berry, 183
 flavonoids, 182
 genistein, 183
 green tea, 183
 silymarin, 183
Polypodium leucotomos , 274, 373; *see also* Botanical
 photoprotection
 Polypropylene , 204
 Polyquaterniums, 222; *see also* Hair-care products
 Polyunsaturated fatty acids , 64, 389; *see also* Gamma-
 linolenic acid-containing vegetable oils
 Polyurethanes, 129, 222; *see also* Hair-care products

- Polyvinyl chloride , 208
- Pomades, 231; *see also* Hair-care products
- POMC, *see* Proopiomelanocortin
- Pomegranate, 275; *see also* Botanical photoprotection
- Porphyrias, 291
- Potts and Guy equation, 129; *see also* Anti-aging topical peptides
- Powder blushers, 205; *see also* Powder cosmetics
- Powder cosmetics, 202; *see also* Decorative cosmetics; Face powders
- color, 205
 - glazing and payoff, 205
 - penetration and drop tests, 205
 - powder blushers, 205
 - pressed powder eye shadows, 205
 - quality assurance of powder products, 205
- PP, *see* Polypropylene
- PPARs, *see* Peroxisome proliferation-activated receptors
- PREP, *see* Pigmented reconstructed epidermis
- Preservatives, 223; *see also* Hair-care products
- Pressed powder eye shadows, 205; *see also* Powder cosmetics
- Primary/straight color, 215; *see also* Decorative cosmetics
- Primary surfactant, 222; *see also* Hair-care products
- Product classification, 430–431
- Pro-inflammatory cytokine IL-1 α , 120; *see also* Niacinamide
- Proliferating cell nuclear antigen , 152
- Proopiomelanocortin , 372
- Pro-oxidant enzymes, 183; *see also* Polyphenols
- Propionibacterium acnes*, 102–103
- Prostaglandin E2 , 7, 375
- Protease-activated receptor-2 , 349, 393; *see also* Botanical extracts
- Protection factor in UVA , 196
- Protein tyrosine , 13
- Protein tyrosine phosphatases , 13
- Proteoglycans, 403; *see also* Biomarine actives
- Protoporphyrin IX, 291
- Proximal nail fold , 261
- Pseudocatalase, 372; *see also* Vitiligo
- Pseudoesters, 403; *see also* Biomarine actives
- Psoralea corylifolia*, 1, 376; *see also* Bakuchiol; Vitiligo
- Psoralea corylifolia* seed , 5; *see also* Bakuchiol
- Psoriasis, 50; *see also* Epicatechin-3-Gallate
- PSP, 150; *see also* Signal oligopeptides
- PTPs, *see* Protein tyrosine phosphatases
- pTyr, *see* Protein tyrosine
- PUFA, *see* Polyunsaturated fatty acids
- Purpura, 365
- benign, 365
 - side effects, 366
 - topical agent effect, 366
 - vitamin K, 365–366
- PVC, *see* Polyvinyl chloride
- Pycnogenol, 276, 352; *see also* Hyperpigmentation treatment; Botanical photoprotection
- Pyranine-6, 149; *see also* Signal oligopeptides
- Pyranine-6, 91; *see also* Kinetin
- 3-Pyridine-carboxamide, *see* Niacinamide
- N-(4-pyridoxylmethylene)-L-serine , 174, 288; *see also* Amino acid derivatives
- PYSer, *see* N-(4-pyridoxylmethylene)-L-serine
- Pyrrolidine dithiocarbamate , 32
- Pyrrolidone carboxylic acid , 167, 238, 336; *see also* Amino acid derivatives; Moisturizers
- ## Q
- Quassia amara*, 320; *see also* Rosacea
- Quaternary ammonium, 222; *see also* Hair-care products
- Quats, *see* Polyquaterniums
- Quinoline, 193; *see also* Organic colorant categories
- ## R
- RA, *see* Retinoic acid
- RAL, *see* Retinaldehyde
- RCAC, *see* *R. rosea*/L-carnosine-associated compound
- RCM, *see* Reflectance confocal microscopy
- Reactive nitrogen species , 177; *see also* Antioxidants
- Reactive oxygen species , 21, 48, 174, 177–178, 282; *see also* Antioxidants; Ultraviolet care
- catalase, 284
 - Fenton reaction, 284
 - effect of various quenchers on collagen cross-linking induced by, 286
- 5 α -Reductase, 327; *see also* Androgenetic alopecia
- Reflectance confocal microscopy , 337
- Repigmentation agents, *see* Vitiligo
- Resin, 222; *see also* Hair-care products
- Resveratrol, 2, 97, 103, 274, 275, 288; *see also* Bakuchiol; Botanical photoprotection
- acne, 102–103
 - antioxidant properties, 98–99
 - background, 97
 - in commercial products, 98
 - cosmeceutical uses, 97
 - photoaging and hyperpigmentation, 100–101
 - photoprotective properties, 99–100
 - scarring, 101
 - skin barrier repair, 99
 - and skin penetration, 97–98
 - uses of, 102
 - wound healing, 101–102
- Retinaldehyde , 348; *see also* Melasma
- Retinoic acid , 9; *see also* Bakuchiol
- Retinoids, 287, 348–349; *see also* Melasma
- Retinol , 2, 348; *see also* Bakuchiol; Melasma
- collagen stimulatory effects, 9
 - gene expression profile of, 5, 10
 - matrix metalloproteinase inhibitory activity of, 8
 - pro-inflammatory gene modulation by, 7
 - volcanic plot of DNA microarray data, 3
- Rhodiola rosea*, 107, 110
- as anti-aging, 108
 - health benefits of, 107–108
 - impact on cultured skin cells, 108–109
 - keratinocytes, 108
 - phytochemistry of, 107

rosarin, 108
 rosavin, 108
 rosin, 108
 and skin applications, 109–110
 Rice peptides, 152; *see also* Enzyme inhibitor peptides
 Rigin, 148; *see also* Signal oligopeptides
 RNS, *see* Reactive nitrogen species
 ROS, *see* Reactive oxygen species
 Rosacea, 315, 323
 adverse reactions, 323
 chibixiao recipe, 321
 cosmeceutical therapy evaluation, 317–319
Crysanthellum indicum extract, 320
 efficacy of botanicals for symptoms, 322–323
 epigallocatechin-3-gallate, 320–321
 feverfew, 316
 licorice extract, 320
 methylsulfonilmethane, 321
 niacinamide, 316
 pathogenesis, 315–316
Quassia amara, 320
 silymarin, 321
 subtypes of, 322
 sulfacetamide 10% /sulfur 5%, 322
 Rosarin, 108; *see also* *Rhodiola rosea*
 Rosavin, 108; *see also* *Rhodiola rosea*
 ROS generated by UV irradiation and skin damage, 284;
see also Ultraviolet care
 Rosin, 108; *see also* *Rhodiola rosea*
R. rosea/L-carnosine-associated compound, 109; *see also*
Rhodiola rosea

S

Salicylic acid, 85, 86; *see also* Hydroxyacids
Sanguinaria canadensis, 273–274; *see also* Botanical
 photoprotection
 SAP, *see* Stable ascorbyl pentapeptide
 Sarcolactic acid, 84; *see also* Hydroxyacids
 SC, *see* Stratum corneum
 Scaling, *see* Flaking
 Scanning electron microscopy, 214
 Scar formation, 101; *see also* Resveratrol
 SCC, *see* Squamous cell carcinoma
 SCCNFP, *see* Scientific Committee on Cosmetic and Non-
 Food Products
 SCF, *see* Stem cell factor
 Scientific Committee on Cosmetic and Non-Food
 Products, 192
 Seaweeds, 405; *see also* Biomarine actives
 Seborrheic dermatitis, 357
 agents for, 362
 agents for modulation of sebum, 359–361
 clinical studies, 358
 differential diagnosis, 357
 risk factors, 357
 shampoo, 362–363
 SELECT, *see* Selenium and Vitamin E Cancer Prevention
 Trial
 Selenium, 186, 301; *see also* Antioxidants
 Selenium and Vitamin E Cancer Prevention Trial, 304
 Selenoenzymes, 302
 L-Selenomethionine, 301–303; *see also* Topical
 antioxidants
 periorbital wrinkle correction, 302
 selenium, 301
 selenoenzymes, 302
 SEM, *see* Scanning electron microscopy
 Senile purpura, 365
 Sequestering agents, 223; *see also* Hair-care products
 Sericite, 204; *see also* Face powders
 Serine palmitoyltransferase, 119
 Serum hormones, 344
 Setting lotions, 231; *see also* Hair-care products
 SFE, *see* Skin fibroblast elastase
 Shampoos, 227–229; *see also* Hair-care products
 Short chain alcohols, 222; *see also* Hair-care products
 Signal acetyl tetrapeptides, 148; *see also* Signal
 oligopeptides
 Signal oligopeptides, 131, 144; *see also* Anti-aging topical
 peptides
 acetylpeptides, 131
 biopeptide-EL, 146–147
 carrier peptides, 131
 cytokinin-like proteins, 131
 Flynn model, 145
 Franz model, 145
 GHK-Cu, 144–145
 GHK-Mn, 144–145
 growth factors, 150
 heat shock proteins, 150–151
 hexapeptides, 147
 interferon- α , 149–150
 keratin, 151
 kinetin, 148–149
 matrikines, 131
 melatonin, 149
 Pal-GHK, 144–145
 Pal-KTTKS, 145–146
 palmitoyl tetrapeptide-7, 147–148
 palmitoyl VGVAPG, 147
 PEP-rpS3, 151
 pyrantine-6, 149
 signal acetyl tetrapeptides, 148
 Syn-Coll, 146
 tripeptide-10 citrulline, 147
 Signal Transducer and Activator of Transcription 3, 14
 Silibinin, 113; *see also* Silymarin
 Silicones, 223; *see also* Hair-care products
 Silk protein, 152–153; *see also* Enzyme inhibitor
 peptides
 Silybin A, 274; *see also* Botanical photoprotection
Silybum marianum, 274; *see also* Botanical
 photoprotection
 Silymarin, 113, 183, 321; *see also* Polyphenols; Rosacea
 anticancer properties, 114
 anti-fibrotic properties, 114
 antioxidant properties, 113
 photoprotective properties, 113–114
 Silymarin/methylsulfonilmethane, 321
 Singlet oxygen, 285; *see also* Ultraviolet care
 Sirtuin 1, 392; *see also* Botanical extracts

- Skin, 297; *see also* Amino acid derivatives; Antioxidants; Decorative cosmetics; Hexylresorcinol ; Moisturizers
aging, 127–128
barrier proteins, 119
color, 74, 211
identical lipids, 242
lighteners, 75
photodamage, 174
- Skin barrier continuum, 331, 338
atopic dermatitis, 332–333
barrier recovery measurement, 338
compromised, 331–332
considerations for infants, 335
contact dermatitis, 333–334
flaking, 336
moisturizer efficacy, 337–338
NMF, 336
proteolytic enzymes, 336
specific physiologic targets, 336–337
treatments and barrier repair, 335
xerosis, 334–335
- Skin coloration, 75; *see also* Hexylresorcinol
- Skin damage prevention, 286; *see also* Sunscreen;
Ultraviolet care
antioxidants, 286–287
anti-wrinkle agents, 288
carotenoids, 287
ion-chelators, 288
- Skin fibroblast elastase , 405; *see also* Biomarine actives
- Skin injury, 31; *see also* Curcumin
basosquamous carcinoma, 39, 40
burns and traumatic wounds, 35–36
bystander effect, 37
cyclobutane pyrimidine dimers and DNA damage, 37
heat shock proteins, 32
hypertrophic scar formation, 36
kB site, 33
laser and IPL injury, 38
multiple actinic keratoses, 43
NF- κ B and I κ B α kinase activation, 33–34
NF- κ B role in, 32–33
periungual squamous cell carcinoma, 41
phosphorylase kinase role in, 34
photodamaged skin, 42, 44
scar tissue formation, 36
second degree burn, 41
sequence of early events in, 31–32
signaling pathways induced by, 31
sites of phosphorylation in I κ B α kinase activation, 33
solar burns, 42
solar elastosis, 43
solar-induced injury pathways, 37
types of, 35
- S-MSM, *see* Silymarin/methylsulfonilmethane
- SNAREs, *see* Soluble N-ethylmaleimide-sensitive factor attachment protein receptors
- SNP, *see* Sodium nitroprusside
- SOD, *see* Superoxide dismutase
- Sodium-dependent vitamin C transporter , 180; *see also* Antioxidants
- Sodium nitroprusside , 99
- Sodium sulfacetamide 10%/sulfur 5% emollient , 322
- Solar-induced injury pathways, 37; *see also* Skin injury
- Solar purpura, 365
- Soluble azo dyes, 192; *see also* Organic pigments
- Soluble N-ethylmaleimide-sensitive factor attachment protein receptors , 153
- Solvent extraction, 387; *see also* Botanical extracts
- Sorption, 223; *see also* Hair-care products
- Soxhlet extraction, *see* Solvent extraction
- Soy, 351–352; *see also* Hyperpigmentation treatment
- Soybean protein, 151–152; *see also* Enzyme inhibitor peptides
- Soybean trypsin inhibitor , 352, 393; *see also* Botanical extracts
- Specialty pigments, 197; *see also* Decorative cosmetics
color pigment complexes, 202
light diffusing pigments, 199
microfine pigments, 199
surface treatments and attributes, 200–201
treated pigments, 199
- Sphingolipids, 404; *see also* Biomarine actives
- SPT, *see* Serine palmitoyltransferase
- Squamous cell carcinoma , 298
- SSSE, *see* Sodium sulfacetamide 10%/sulfur 5% emollient
- Stable ascorbyl pentapeptide , 146; *see also* Signal oligopeptides
- Starch, 204; *see also* Face powders
- STAT3, *see* Signal Transducer and Activator of Transcription 3
- Stem cell factor , 393; *see also* Botanical extracts
- STI, *see* Soybean trypsin inhibitor
- Stratum corneum , 9, 85
- Stratum granulosum , 172, 331; *see also* Skin barrier continuum
- Substantivity, 223; *see also* Hair-care products
- Sulforaphane, 392; *see also* Botanical extracts
- Sunburn, 281
- Sun protection factor , 195, 290; *see also* Sunscreen
- Sunscreen, 185, 223, 288, 300; *see also* Antioxidants;
Hair-care products; Botanical photoprotection;
Skin damage prevention; Ultraviolet care
application of, 290
limitations of, 300
microsporine like amino acids, 405
photoactivation prevention, 291
products, 269
SPF values of various application amounts, 290
sun protection factor, 290
UVA protection, 290
UV filters, 288, 289, 290
- Superoxide dismutase , 99, 108, 178; *see also* Antioxidants
- Surfactant, 223; *see also* Hair-care products
- Survivin, 100; *see also* Resveratrol
- SVCT2, *see* Sodium-dependent vitamin C transporter
- Syn-Coll, 146; *see also* Signal oligopeptides
- Syndecan-1, 131

Synthetic polymers, 223; *see also* Hair-care products
 Sytenol®, 1; *see also* Bakuchiol

T

Talc, 203; *see also* Face powders
 Tazarotene-inducible gene 1, 11
 TDRs, *see* Thioredoxin reductases
 TEA, *see* Triethanolamine
 TEM, *see* Transmission electron microscopy
 12-O-Tetradecanoylphorbol 13-acetate, 6, 114
 TEWL, *see* Transepidermal water loss
 Texturizing agents, 207; *see also* Foundation
 TG-2, *see* Transglutaminase-2
 Therapeutic marine extracts, 403; *see also* Biomarine actives
 Thiol antioxidant, 184; *see also* Antioxidants
 Thioredoxin reductases, 301
 Thromboxane B2, 6
 Thrombosponin I, 146; *see also* Signal oligopeptides
Thuja occidentalis semen, 327; *see also* Androgenetic alopecia
 Thymic stromal lymphopoietin, 51
 TIG1, *see* Tazarotene-inducible gene 1
 TIMPs, *see* Tissue inhibitors of metalloproteinases
 TiO₂, *see* Titanium dioxide
 TiO₂ and ZnO, 195; *see also* Inorganic pigments
 composite series, 196
 nano, 195
 non-nano, 196
 Tissue inhibitors of metalloproteinases, 8
 Titanium dioxide, 194; *see also* Inorganic pigments;
 Pearlescent pigments
 coated mica, 198
 in sunscreens, 195
 TLR-2, *see* Toll-like receptor 2
 TNF, *see* Transforming growth factors
 TNF α , *see* Tumor necrosis factor- α
 TNF α receptor activating factor-1, 33
 TNF α receptor activating factor-2, 33
 TNS, 150; *see also* Signal oligopeptides
 Tocopherol, 303; *see also* Bakuchiol; Vitamin E antioxidant, 5
 Tocotrienol, 303; *see also* Vitamin E
 Toll-like receptor 2, 120, 362; *see also* Seborrhic dermatitis
 Toner, 192, 215; *see also* Decorative cosmetics; Organic pigments
 Topical antioxidants, 297, 308–309; *see also* Antioxidant advantages of, 301
 environmental damage, 297–299
 erythema inhibition, 308
 L-selenomethionine, 301–303
 mutagenic oxidative intermediates, 298
 skin tumor multiplicity, 299
 smoking caused wrinkles, 298
 sunscreens, 300
 synergistic carcinogenesis, 299
 synergy in chemo-photocarcinogenesis, 300
 vitamin C + E + ferulic acid, 308, 309

 vitamin C + E, 307
 vitamin C, 305–307
 vitamin E, 303–305
 TOS, *see* *Thuja occidentalis* semen
 TPA, *see* 12-O-Tetradecanoylphorbol 13-acetate
 TRAF1, *see* TNF α receptor activating factor-1
 TRAF2, *see* TNF α receptor activating factor-2
 Transepidermal water loss, 62, 119, 237, 282
 Transforming growth factors, 131
 -beta 1, 36, 101
 Transglutaminase-2, 73
 Transmission electron microscopy, 214
 Treated pigments, 199; *see also* Specialty pigments
 Trehalose, 232; *see also* Hair-care products
 Triarylmethane, 192; *see also* Organic colorant categories
 Triethanolamine, 163; *see also* Amino acid derivatives
 Tripeptide-10 citrulline, 131, 147; *see also* Anti-aging topical peptides; Signal oligopeptides
 Tripeptide-3, 154; *see also* Neurotransmitter inhibitor peptides
 True pigment, 192; *see also* Organic pigments
 TSLP, *see* Thymic stromal lymphopoietin
 TSPI, *see* Thrombosponin I
 Tumor necrosis factor- α , 32, 118, 298, 307
 Tumor suppressor p53, 13–14
 Two-color effect, 198
 TXB2, *see* Thromboxane B2
 Tyrosinase, 55, 109

U

UA, *see* Urocanic acid
 UHPLC, *see* Ultra high performance liquid chromatography
 Ultra high performance liquid chromatography, 415, 416, 418, 422
 Ultramarines, 197; *see also* Inorganic pigments
 Ultraviolet, 19, 281; *see also* Botanical photoprotection;
 Sunscreens
 filters, 288, 290
 UVA radiation, 290, 436
 UVB radiation, 269
 Ultraviolet A protection factor, 290
 Ultraviolet care, 281, 291; *see also* Skin damage prevention; Sunscreens
 cell life span shortening, 283
 immunohistochemical staining of modified tyrosine residue, 283
 Langerhans cells in UVB-irradiated specimens, 283
 lipid peroxide, 285–286
 reactive oxygen species, 284–285
 singlet oxygen, 285
 UV-induced skin damage, 281–284
 Ultraviolet radiation, 177
 Urocanic acid, 170; *see also* Amino acid derivatives
 USDA, *see* U.S. Department of Agriculture
 U.S. Department of Agriculture, 429, 438
 U.S. Food and Drug Administration, 85, 385, 290; *see also* Botanical extracts
 UV, *see* Ultraviolet

UVAPF, *see* Ultraviolet A protection factor

UVR, *see* Ultraviolet radiation

V

VAS, *see* Visual analogue scale

Vascular endothelial growth factor , 22, 101

VEGF, *see* Vascular endothelial growth factor

Very low density lipoproteins , 118

Visual analogue scale , 365

Visual effects, 223; *see also* Hair-care products

Vitamin C, 182, 276, 305–307; *see also* Antioxidants;

 Botanical photoprotection

 antiaging effects of, 306

 as anti-inflammatory, 307

 vitamin C + E + ferulic acid, 308

 vitamin C + E, 307

Vitamin D, 371; *see also* Vitiligo

Vitamin E, 181–182, 276; *see also* α -Tocopherol;

 Antioxidants; Botanical photoprotection

 concentration, 304

 isoform, 304

 periorbital wrinkle correction, 305

 structures, 303

Vitiligo, 369, 377

 afamelanotide, 371–372

 alternative therapies, 376

 antioxidant properties, 374

 ayurvedic medicine, 376

 calcineurin inhibitors, 371

 classification of, 370

 dead sea climatotherapy, 373

Ginkgo biloba, 377

 herbal remedies, 376–377

 immunomodulating properties, 374

 immunomodulatory effects, 374–375

 melagenina, 377

 oral antioxidants with NBUVB, 375

 oral *P. Leucotomos* in combination with narrow-band

 UVB, 375

 pathophysiology of, 370

 photochemotherapy and NBUVB, 371

Polypodium leucotomos, 373–374

 pseudocatalase, 372

 therapies for, 378

 topical prostaglandin E, 375–376

 topical therapies, 370

 vitamin D analogues, 371

VLDL, *see* Very low density lipoproteins

VOC, *see* Volatile organic compound

Volatile organic compound , 213

W

Wagerlin-1, 154; *see also* Neurotransmitter inhibitor
 peptides

Water-in-oil , 236

Waxes, 207; *see also* Foundation

Wetting agents, 207; *see also* Foundation

WHI, *see* Women's Health Initiative

W/O, *see* Water-in-oil

Women's Health Initiative , 20

Wound healing, 101; *see also* Resveratrol

X

Xanthenes, 192; *see also* Organic colorant categories

Xerosis, 334–335; *see also* Skin barrier continuum;

 Moisturizers

 cutis, 235

 pathophysiology of, 334

Y

Yellow skin syndrome, 118; *see also* Niacinamide

Z

Zeatin, 91; *see also* Kinetin

 structure of, 92

Zinc oxide , 194–195; *see also* Inorganic pigments

 in sunscreens, 195

Zinc stearate, 204

ZnO, *see* Zinc oxide